

2033ES ELECTRICAL SCHEMATIC

SERIAL #8800101 THROUGH #8802623

WIRE HARNESS
PART NUMBERS:
MAIN: 8764
CONTROL BOX: 8346, 8331
CORD: 7656
BEAMS: 8540
MOTION ALARM: 8782
HOUR METER: 8783
VOLT METER: 8784

o/o N/C

o/o N/C HELD OPEN

o/o N/O

o/o N/O HELD CLOSED

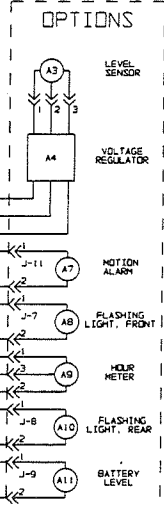
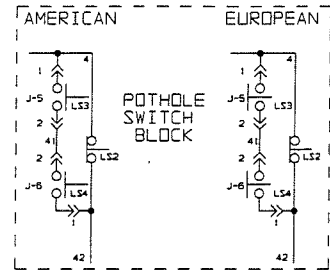
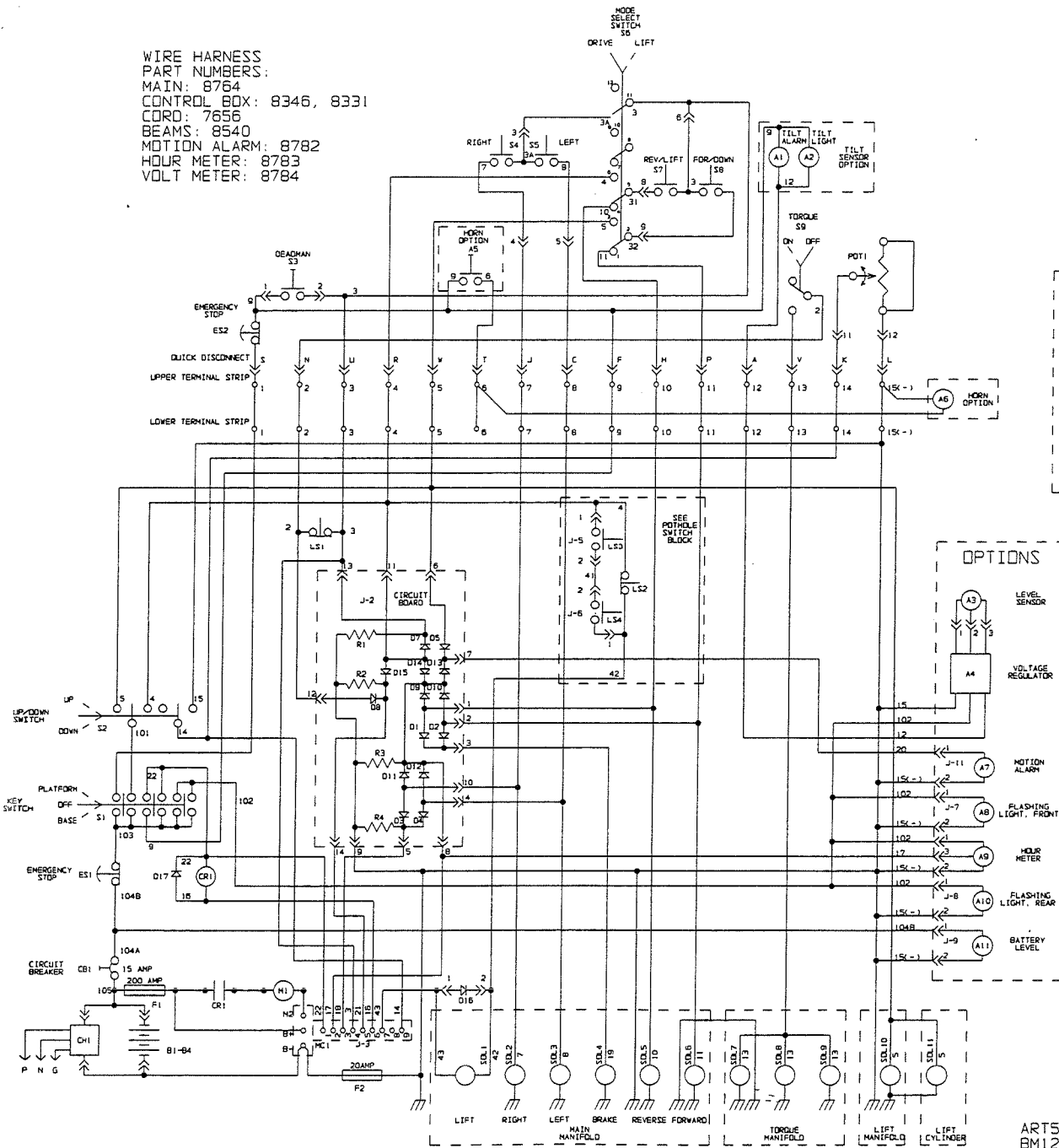

ART542 R3
BM12157
6/6/97

Figure 2-2. 2033ES Electrical Schematic

NOTES: (UNLESS OTHERWISE SPECIFIED)

1. SWITCH S1 'KEY SWITCH' MAKES CONTACT TO THE RIGHT SET OF CONTACTS WHEN THE SWITCH IS PLACED IN THE BASE POSITION.
2. SWITCH S2 'UP-DOWN SWITCH' MAKES CONTACT FROM THE CENTER TO THE LEFT WHEN THE SWITCH IS HELD IN THE DOWN POSITION.
3. SWITCH L51, AND L52 GOES FROM N/C TO N/O WHEN THE PLATFORM REACHES 7FEET.
4. SWITCH LS3 GOES FROM N/O TO N/C WHEN THE LEFT POTHOLE BAR IS LOWERED COMPLETELY.
5. SWITCH LS4 GOES FROM N/O TO N/C WHEN THE RIGHT POTHOLE BAR IS LOWERED COMPLETELY.
6. UNIT SHOWN IN STOWED POSITION WITH POTHOLE BAR IN UP POSITION.

ITEM	PART NO.	QTY.	DESCRIPTION	FUNCTION	LOCATION
A1-A4	13512	1	TILT SENSOR OPTION PACKAGE	WARN WHEN MACHINE IS AT 4 DEG.	UNDER CHARGER & IN CONTROL BOX
A5-A6	13764	1	PLATFORM MOUNTED HORN PACKAGE	OPERATOR ACTIVATED HORN	CONTROL BOX AND UNDER PLATFORM
A7	13856	1	MOTION ALARM PACKAGE	WARN OF A MOVEMENT	BEHIND LOWER CONTROL PANEL
A8, A10	13431	2	FLASHING LIGHT PACKAGE	WARN OF A POWERED UP MACHINE	NEXT TO TANK, NEXT TO CHARGER
A9	13855	1	HOUR METER PACKAGE	RECORD TIME THAT IS MACHINE IS BEING USED	LOWER CONTROL PANEL
A11	13854	1	BATTERY INDICATOR PACKAGE	SHOW BATTERY STATUS	LOWER CONTROL PANEL
B1-B4	XXXX	4	6 VOLT DEEP CYCLE BATTERY	POWER FOR THE MOTOR AND CONTROL CIRCUIT	INSIDE BATTERY COMPARTMENT
C81	7235	1	CIRCUIT BREAKER - 15 AMP MANUAL	CONTROL CIRCUIT PROTECTION	LOWER CONTROL PANEL
CR1	5967	1	24 VOLT CONTACTOR	ALLOW MOTOR TO TURN ON	MOTOR CABINET
D1-D15	8601	1	CIRCUIT BOARD FOR UNITS W/ SEVCON	DIRECT SIGNALS TO THE PROPER LOCATION	MOTOR CABINET NEAR TERM. STRIP
D16	8480	1	PLUG-IN DIODE PACK	SUPPRESSION DIODE	MAIN MANIFOLD LIFT VALVE
D17	8368	1	DIODE W/ RING TERMINALS	SUPPRESSION DIODE	CROSS CONTACTOR COIL
E51	7800	1	SWITCH, EMERGENCY STOP	SHUTDOWN ALL MOVING FUNCTIONS	LOWER CONTROL PANEL
E52	7800	1	SWITCH, EMERGENCY STOP	SHUTDOWN ALL PLATFORM MOVING FUNCTIONS	UPPER CONTROL BOX
F1	8344	1	FUSE, 200 AMP	MAIN LINE FUSE	MOTOR CABINET
F2	7275	1	FUSE, 20 AMP SERVICE PACK	CONTROL GROUND FUSE	MOTOR CABINET
LS1	8776	1	SWITCH, LIMIT	ENABLE HIGH SPEED	MOTOR CABINET
LS2	8776	1	SWITCH, LIMIT	LIFT ENABLE	UNDER CHARGER
LS3-EUR	8776	1	SWITCH, LIMIT	DETECT POTHOLE BAR LOCATION	UNDER CHARGER
LS3-AHE	8696	1	SWITCH, LIMIT V7	DETECT POTHOLE BAR LOCATION	NEAR POTHOLE LEVERS
LS4-EUR	8776	1	SWITCH, LIMIT	DETECT POTHOLE BAR LOCATION	UNDER CHARGER
LS4-AHE	8696	1	SWITCH, LIMIT V7	DETECT POTHOLE BAR LOCATION	NEAR POTHOLE LEVERS
M1	8544	1	MOTOR, 24 VOLT, 2 HP	TURN THE HYDRAULIC PUMP	MOTOR CABINET
M2	8539	1	POTENTIOMETER, 20K OHMS	CHANGES THE MOTOR SPEED	MOTOR CABINET
POT1	13527	1	POTENTIOMETER, 20K OHMS	SENSES THE OPERATOR INPUT	MOTOR CABINET
S1	8787	1	SWITCH, KEY	ALLOWS BASE OR PLATFORM CONTROLS TO BE USED	UPPER CONTROL BOX
S2	5694	1	SWITCH, TOGGLE 2 POLE 3 POS.	ALLOWS LIFT/LOWER FUNCTIONS AT BASE CONTROLS	LOWER CONTROL PANEL
S3	8753	1	SWITCH, PUSH-BUTTON	ENABLES OTHER FUNCTION TO BE USED AT PLATFORM	UPPER CONTROL PANEL
S4	8448	1	SWITCH, LIMIT V3	RIGHT TURN SWITCH	UPPER CONTROL BOX, HANDLE
S5	8448	1	SWITCH, LIMIT V3	LEFT TURN SWITCH	UPPER CONTROL BOX, HANDLE
S6	8638	1	SWITCH, TOGGLE 4 POLE 2 POS.	ALLOW EITHER LIFT OR DRIVE FUNCTIONS	UPPER CONTROL BOX, HANDLE
S7	8696	1	SWITCH, LIMIT V7	REVERSE OR LIFT SWITCH	UPPER CONTROL BOX
S8	8696	1	SWITCH, LIMIT V7	FORWARD OR DOWN SWITCH	UPPER CONTROL BOX
S9	5630	1	SWITCH, TOGGLE 1 POLE 2 POS.	TORQUE SWITCH	UPPER CONTROL BOX
SOL1	7833	1	COIL, 24 VOLT 2 SPADE	ACTIVATES LIFT VALVE	MAIN MANIFOLD
SOL2	6163	1	COIL, 24 VOLT SINGLE SPADE	ACTIVATES RIGHT TURN VALVE	MAIN MANIFOLD
SOL3	6163	1	COIL, 24 VOLT SINGLE SPADE	ACTIVATES LEFT TURN VALVE	MAIN MANIFOLD
SOL4	6163	1	COIL, 24 VOLT SINGLE SPADE	ACTIVATES BRAKE VALVE	MAIN MANIFOLD
SOL5	6163	1	COIL, 24 VOLT SINGLE SPADE	ACTIVATES REVERSE	MAIN MANIFOLD
SOL6	6163	1	COIL, 24 VOLT SINGLE SPADE	ACTIVATES FORWARD	MAIN MANIFOLD
SOL7,8,9	6163	3	COIL, 24 VOLT SINGLE SPADE	ACTIVATES TORQUE VALVES	TORQUE MANIFOLD
SOL10	6163	1	COIL, 24 VOLT SINGLE SPADE	ACTIVATES DOWN VALVE	LIFT MANIFOLD
SOL11	7833	1	COIL, 24 VOLT 2 SPADE	ACTIVATES DOWN VALVE	LIFT CYLINDER

Figure 2-2. 2033ES Electrical Schematic

2033ES ELECTRICAL SCHEMATIC

SERIAL #8802624 THROUGH PRESENT

WIRE HARNESS
 PART NUMBERS:
 MAIN: 9548
 CONTROL BOX: 8346, 8331
 CORD: 7656
 BEAMS: 8540
 MOTION ALARM: 8782
 HOUR METER: 8783
 VOLT METER: 8784

o/o N/C

o/o N/C HELD OPEN

o/o N/D

o/o N/D HELD CLOSED

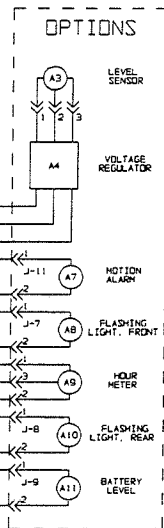
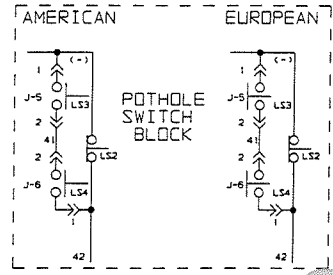
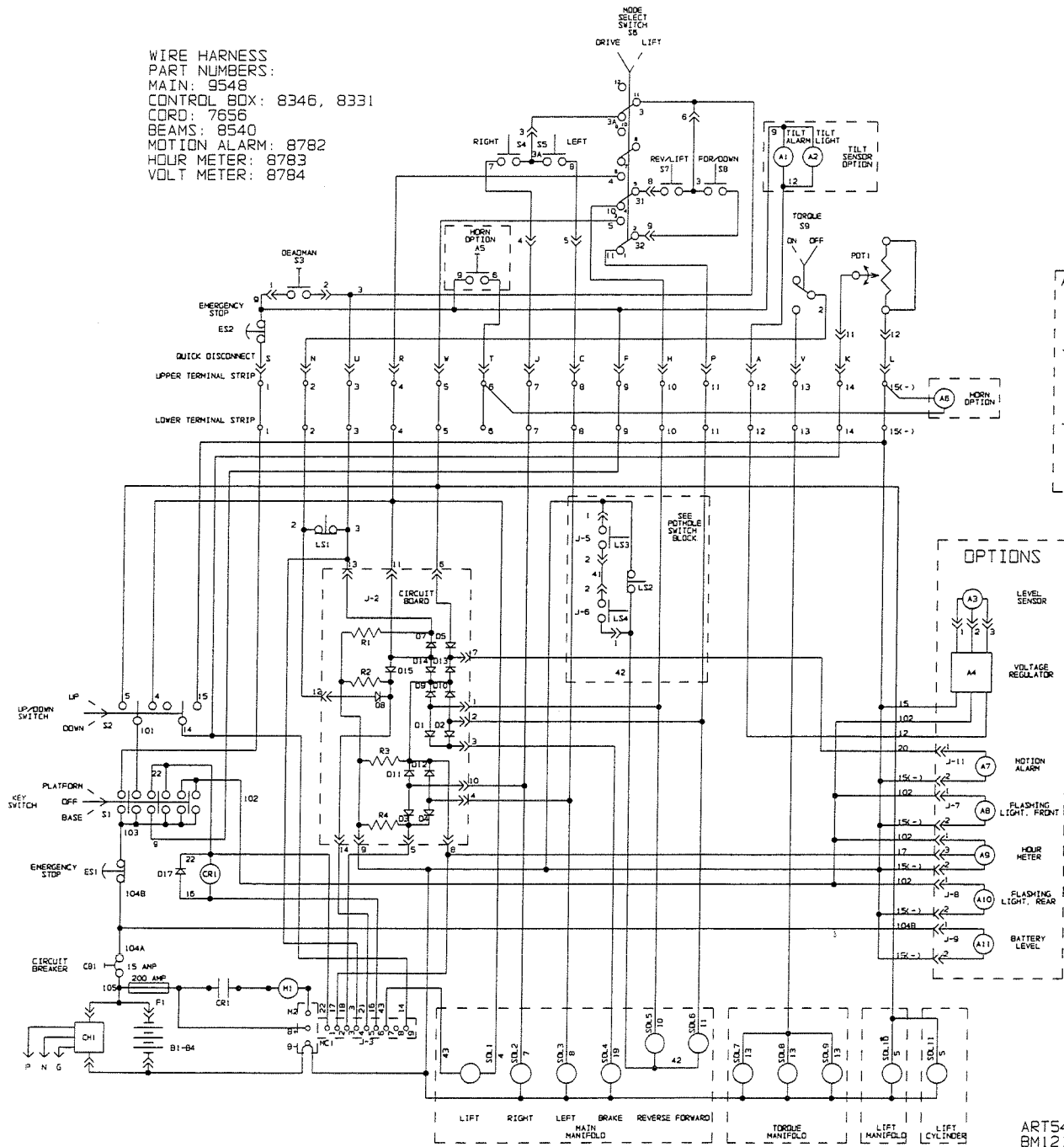

ART542 R4
 BM12157
 12/23/98

Figure 2-2a. 2033ES Electrical Schematic

NOTES: (UNLESS OTHERWISE SPECIFIED)

1. SWITCH S1 "KEY SWITCH" MAKES CONTACT TO THE RIGHT SET OF CONTACTS WHEN THE SWITCH IS PLACED IN THE BASE POSITION.
2. SWITCH S2 "UP/DOWN SWITCH" MAKES CONTACT FROM THE CENTER TO THE LEFT WHEN THE SWITCH IS HELD IN THE DOWN POSITION.
3. SWITCH LS1, AND LS2 GOES FROM N/C TO N/D WHEN THE PLATFORM REACHES 7FEET.
4. SWITCH LS3 GOES FROM N/D TO N/C WHEN THE LEFT POTHOLE BAR IS LOWERED COMPLETELY.
5. SWITCH LS4 GOES FROM N/D TO N/C WHEN THE RIGHT POTHOLE BAR IS LOWERED COMPLETELY.
6. UNIT SHOWN IN STOWED POSITION WITH POTHOLE BAR IN UP POSITION.





ITEM	PART NO.	QTY.	DESCRIPTION	FUNCTION	LOCATION
A1-A4	13512	1	TILT SENSOR OPTION PACKAGE	WARN WHEN MACHINE IS AT 4 DEG.	UNDER CHARGER & IN CONTROL BOX
A5-A6	13764	1	PLATFORM MOUNTED HORN PACKAGE	OPERATOR ACTIVATED HORN	CONTROL BOX AND UNDER PLATFORM
A7	13856	1	MOTION ALARM PACKAGE	WARN OF A MOVEMENT	BEHIND LOWER CONTROL PANEL
A8,A10	13431	2	FLASHING LIGHT PACKAGE	WARN OF A POWERED UP MACHINE	NEXT TO TANK, NEXT TO CHARGER
A9	13855	1	HOUR METER PACKAGE	RECORD TIME THAT IS MACHINE IS BEING USED	LOWER CONTROL PANEL
A11	13854	1	BATTERY INDICATOR PACKAGE	SHOW BATTERY STATUS	LOWER CONTROL PANEL
B1-B4	XXXX	4	6 VOLT DEEP CYCLE BATTERY	POWER FOR THE MOTOR AND CONTROL CIRCUIT	INSIDE BATTERY COMPARTMENT
CB1	7235	1	CIRCUIT BREAKER - 15 AMP MANUAL	CONTROL CIRCUIT PROTECTION	LOWER CONTROL PANEL
CR1	5967	1	24 VOLT CONTACTOR	ALLOW MOTOR TO TURN ON	MOTOR CABINET
D1-D15	8601	1	CIRCUIT BOARD FOR UNITS W/ SEVCON	DIRECT SIGNALS TO THE PROPER LOCATION	MOTOR CABINET NEAR TERM. STRIP
D17	8368	1	DIODE W/ RING TERMINALS	SUPRESION DIODE	ACROSS CONTACTOR COIL
ES1	7800	1	SWITCH, EMERGENCY STOP	SHUTDOWN ALL MOVING FUNCTIONS	LOWER CONTROL PANEL
ES2	7800	1	SWITCH, EMERGENCY STOP	SHUTDOWN ALL PLATFORM MOVING FUNCTIONS	UPPER CONTROL BOX
F1	8344	1	FUSE, 200 AMP	MAIN LINE FUSE	MOTOR CABINET
LS1	8776	1	SWITCH, LIMIT	ENABLE HIGH SPEED	UNDER CHARGER
LS2	8776	1	SWITCH, LIMIT	LIFT ENABLE	UNDER CHARGER
LS3-EUR	8776	1	SWITCH, LIMIT	DETECT POTHOLE BAR LOCATION	UNDER CHARGER
LS3-AME	8696	1	SWITCH, LIMIT V7	DETECT POTHOLE BAR LOCATION	NEAR POTHOLE LEVERS
LS4-EUR	8776	1	SWITCH, LIMIT	DETECT POTHOLE BAR LOCATION	UNDER CHARGER
LS4-AME	8696	1	SWITCH, LIMIT V7	DETECT POTHOLE BAR LOCATION	NEAR POTHOLE LEVERS
M1	8544	1	MOTOR, 24 VOLT, 2 HP	TURN THE HYDRAULIC PUMP	MOTOR CABINET
MC1	8539	1	CONTROLLER, DC 250 AMP	CHANGES THE MOTOR SPEED	MOTOR CABINET
POT1	13527	1	POTENTIOMETER, 20K OHMS	SENSES THE OPERATOR INPUT	UPPER CONTROL BOX
S1	8787	1	SWITCH, KEY	ALLOWS BASE OR PLATFORM CONTROLS TO BE USED	LOWER CONTROL PANEL
S2	5694	1	SWITCH, TOGGLE 2 POLE 3 POS.	ALLOWS LIFT/LOWER FUNCTIONS AT BASE CONTROLS	LOWER CONTROL PANEL
S3	8753	1	SWITCH, PUSH-BUTTON	ENABLES OTHER FUNCTION TO BE USED AT PLATFORM	UPPER CONTROL BOX, HANDLE
S4	8448	1	SWITCH, LIMIT V3	RIGHT TURN SWITCH	UPPER CONTROL BOX, HANDLE
S5	8448	1	SWITCH, LIMIT V3	LEFT TURN SWITCH	UPPER CONTROL BOX, HANDLE
S6	8638	1	SWITCH, TOGGLE 4 POLE 2 POS.	ALLOW EITHER LIFT OR DRIVE FUNCTIONS	UPPER CONTROL BOX
S7	8696	1	SWITCH, LIMIT V7	REVERSE OR LIFT SWITCH	UPPER CONTROL BOX
S8	8696	1	SWITCH, LIMIT V7	FORWARD OR DOWN SWITCH	UPPER CONTROL BOX
S9	5630	1	SWITCH, TOGGLE 1 POLE 2 POS.	TORQUE SWITCH	UPPER CONTROL BOX
SOL1	8914	1	COIL, 24 VOLT 2 SPADE	ACTIVATES LIFT VALVE	MAIN MANIFOLD
SOL2	8914	1	COIL, 24 VOLT SINGLE SPADE	ACTIVATES RIGHT TURN VALVE	MAIN MANIFOLD
SOL3	8914	1	COIL, 24 VOLT SINGLE SPADE	ACTIVATES LEFT TURN VALVE	MAIN MANIFOLD
SOL4	8914	1	COIL, 24 VOLT SINGLE SPADE	ACTIVATES BRAKE VALVE	MAIN MANIFOLD
SOL5	8914	1	COIL, 24 VOLT SINGLE SPADE	ACTIVATES REVERSE	MAIN MANIFOLD
SOL6	8914	1	COIL, 24 VOLT SINGLE SPADE	ACTIVATES FORWARD	MAIN MANIFOLD
SOL7,8,9	8914	3	COIL, 24 VOLT SINGLE SPADE	ACTIVATES TORQUE VALVES	TORQUE MANIFOLD
SOL10	6163	1	COIL, 24 VOLT SINGLE SPADE	ACTIVATES DOWN VALVE	LIFT MANIFOLD
SOL11	7833	1	COIL, 24 VOLT 2 SPADE	ACTIVATES DOWN VALVE	LIFT CYLINDER

Figure 2-2a. 2033ES Electrical Schematic

2033ES ELECTRICAL SCHEMATIC

8803214-8803999

WIRE HARNESS PART NUMBERS:
 MAIN: 90224
 CONTROL BOX: 8346, 90100
 CORD: 7656
 BEAMS: 8540
 MOTION ALARM: 8782
 HOUR METER: 8783
 VOLT METER: 8784

 N/C
 N/C HELD OPEN
 N/D
 N/D HELD CLOSED

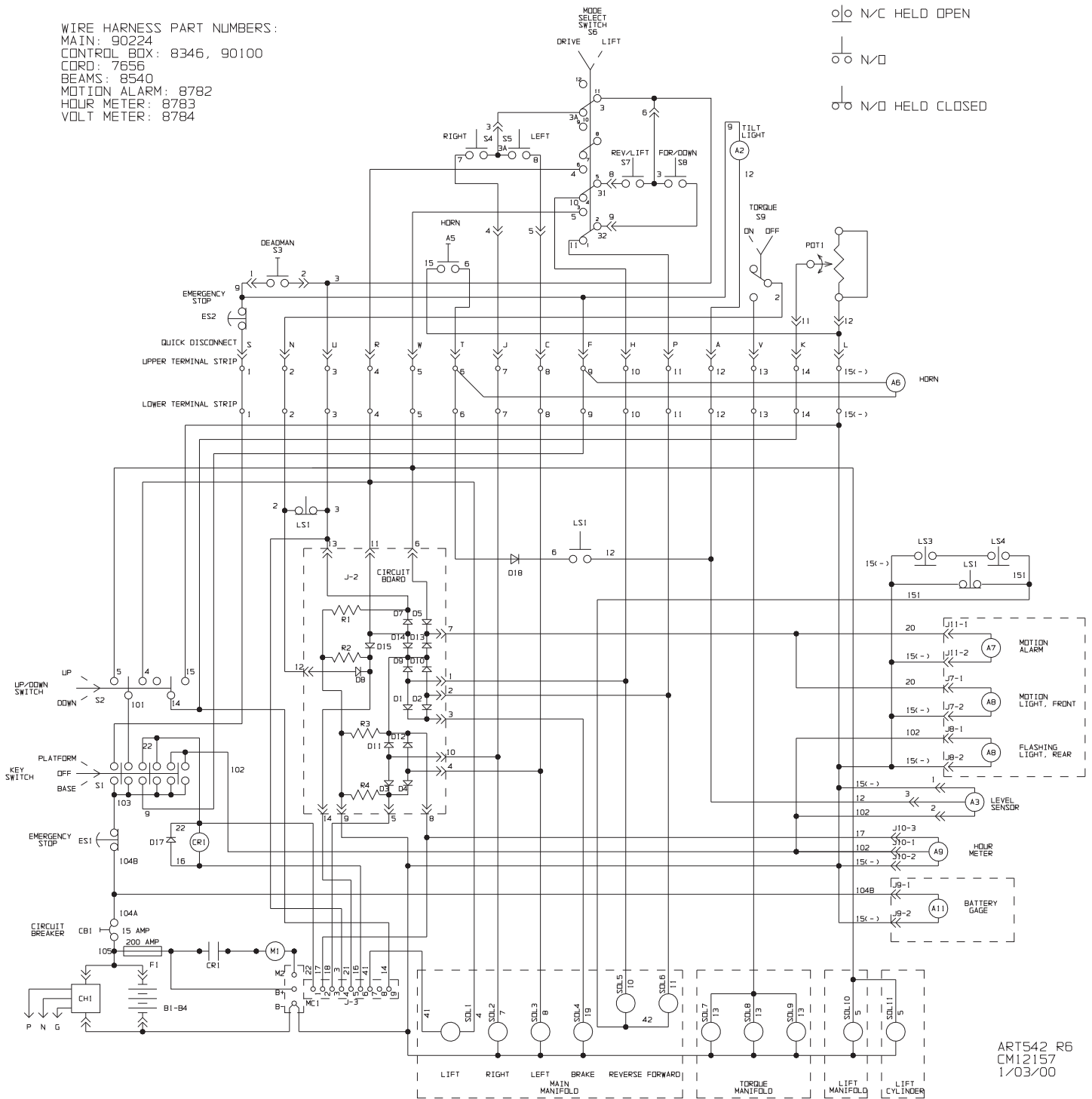

NOTES: (UNLESS OTHERWISE SPECIFIED)

1. SWITCH S1 "KEY SWITCH" MAKES CONTACT TO THE RIGHT SET OF CONTACTS WHEN THE SWITCH IS PLACED IN THE BASE POSITION.
2. SWITCH S2 "UP/DOWN SWITCH" MAKES CONTACT FROM THE CENTER TO THE LEFT WHEN THE SWITCH IS HELD IN THE DOWN POSITION.
3. SWITCH LS1 GOES FROM N/C TO N/D WHEN THE PLATFORM REACHES 7 FEET.
4. SWITCH LS3 GOES FROM N/D TO N/C WHEN THE LEFT POTHOLE BAR IS LOWERED COMPLETELY.
5. SWITCH LS4 GOES FROM N/D TO N/C WHEN THE RIGHT POTHOLE BAR IS LOWERED COMPLETELY.
6. UNIT SHOWN IN STOWED POSITION WITH POTHOLE BAR IN UP POSITION.

ART542 R6
 CM12157
 1/03/00

PRESSURE SETTINGS	
MAIN RELIEF	2750 PSI
LIFT	2200 PSI
STEERING	800 PSI
COUNTERBALANCE	450 PSI

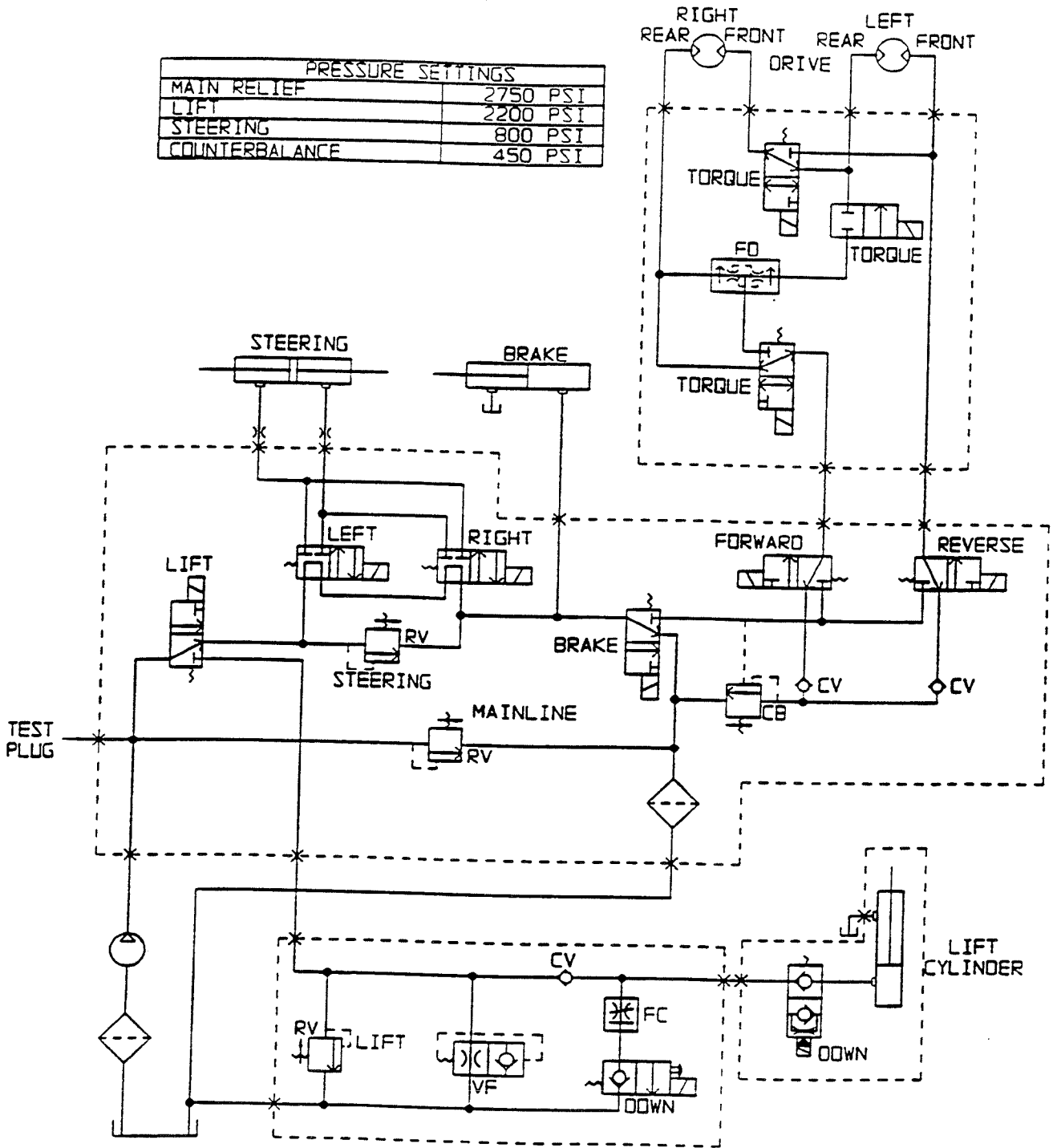

ART 562 R2
 8M12307
 7/24/97

Figure 2-3 2033ES Hydraulic Assembly

PRESSURE SETTINGS	
MAIN RELIEF	2750 PSI
LIFT	2200 PSI
STEERING	800 PSI
COUNTERBALANCE	400 PSI

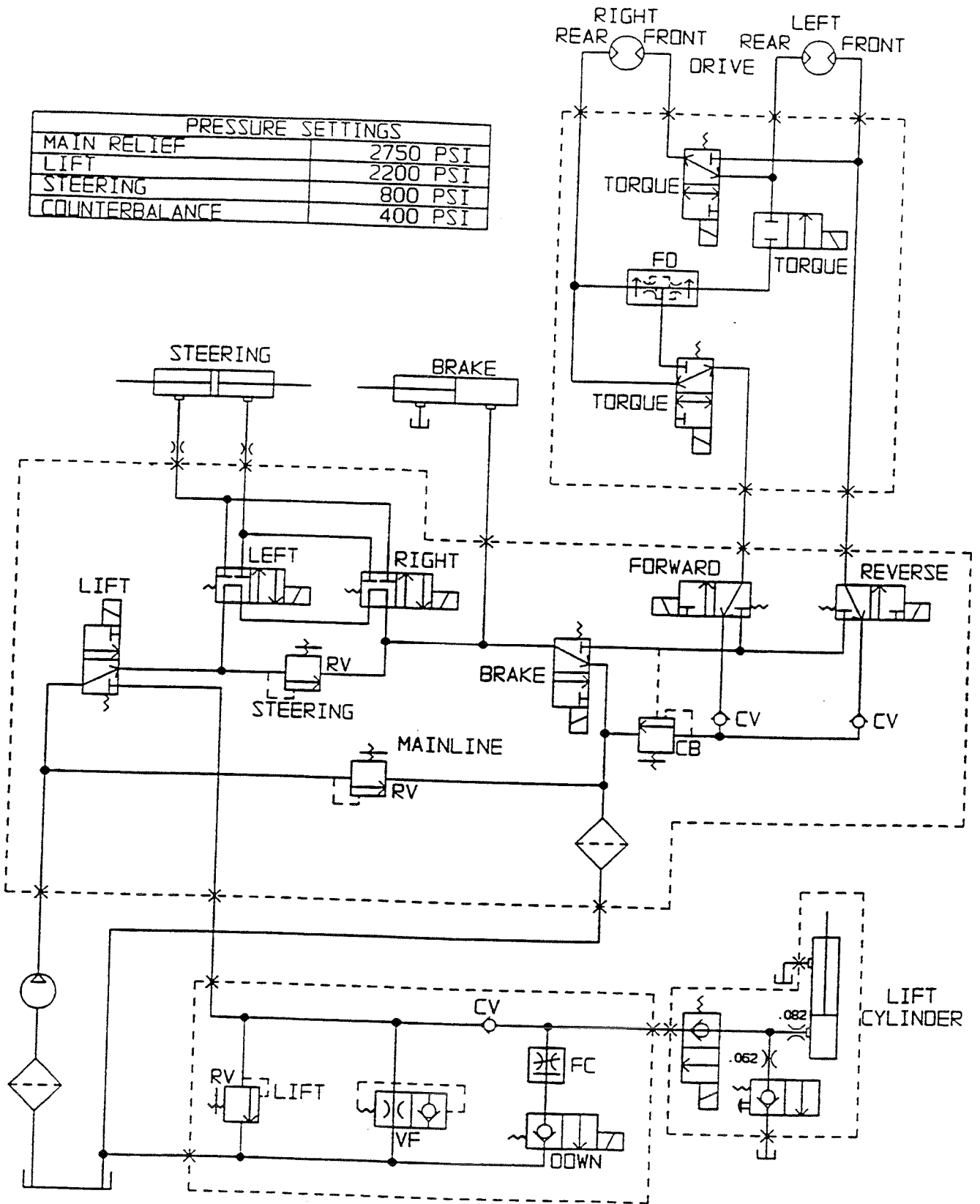

ART563 R2
 BM12308
 3/24/97

Figure 2-4. 2033ES Hydraulic Schematic - Europe

Serial # 8800101 - 8802623

13863 - MAIN MANIFOLD

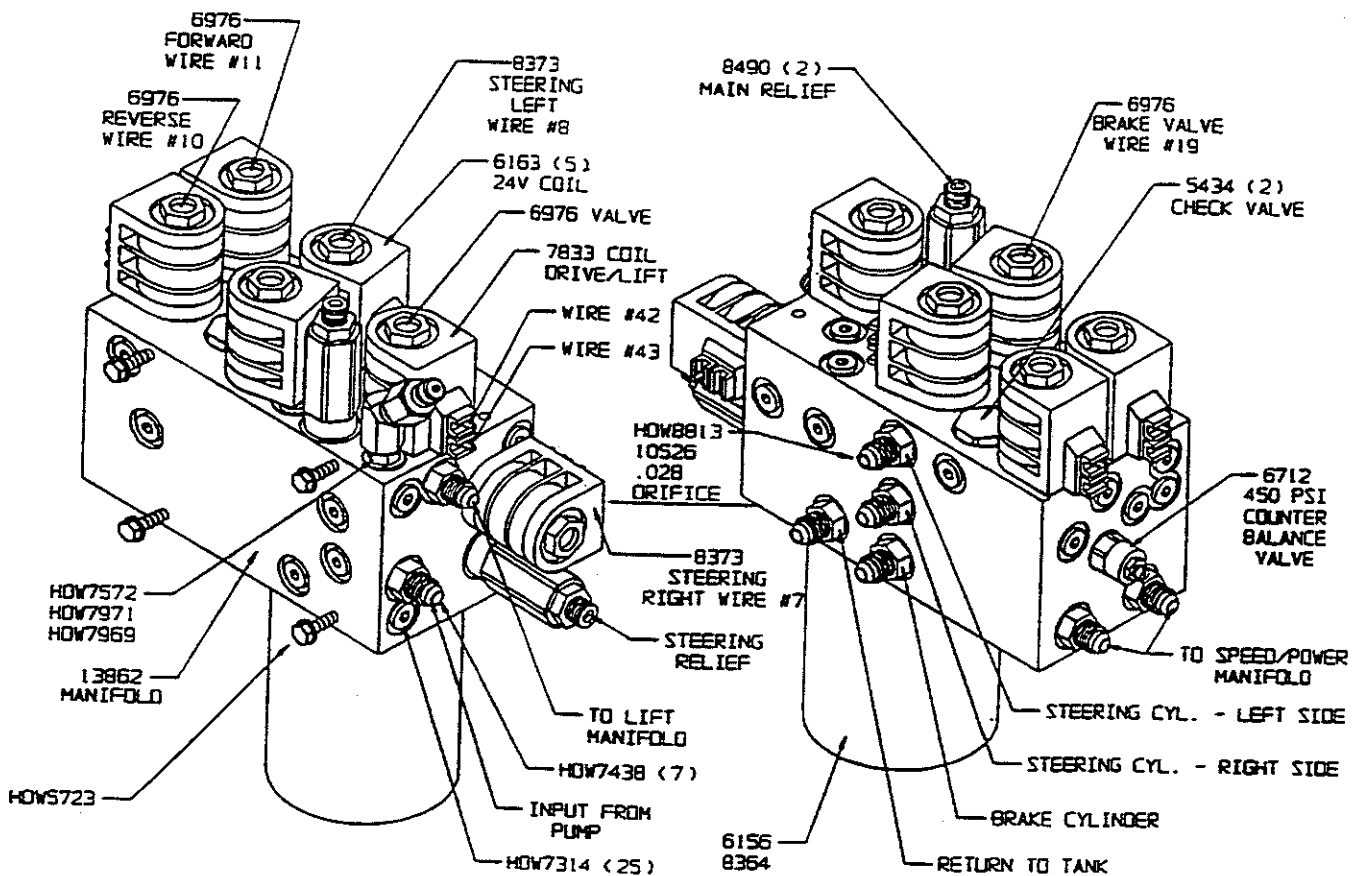

ART566 R3
8N12335
1/20/97

Figure 7-3. 2033ES Main Hydraulic Manifold

13347 - LOWERING MANIFOLD

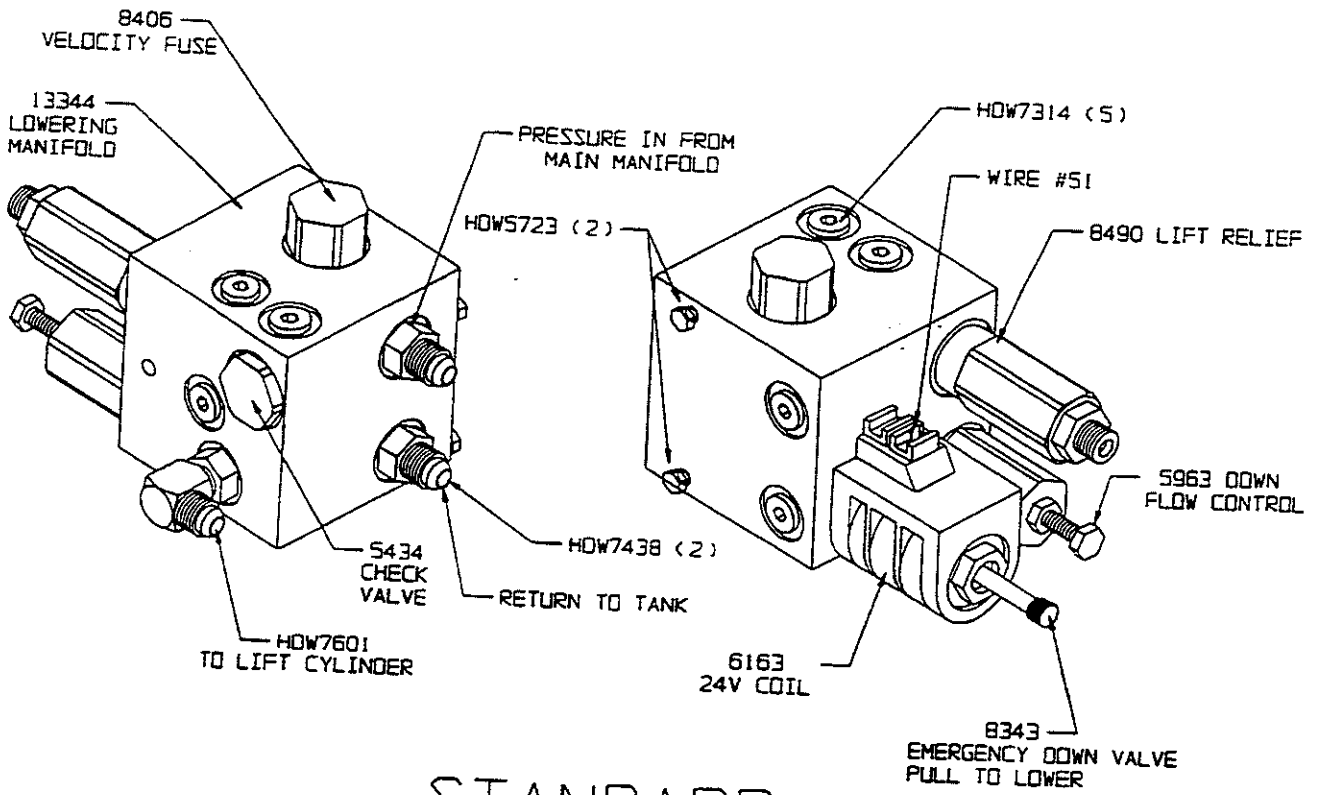

STANDARD

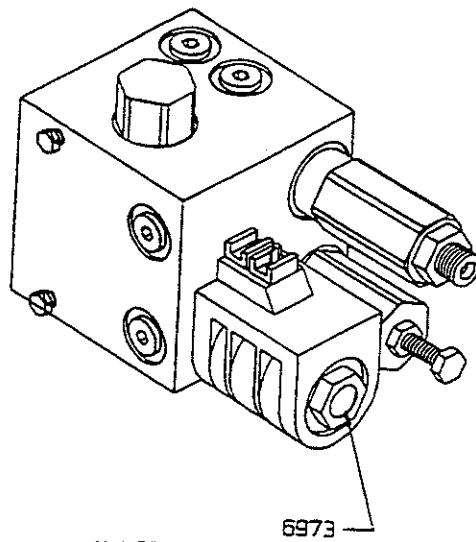

MANIFOLD ASSEMBLY IS IDENTICAL TO 13347 EXCEPT FOR EMERGENCY DOWN VALVE

EUROPEAN

ART327 85
 8/1/84
 11/8/86

Figure 7-5. 2033ES LOWERING MANIFOLD

Serial # 8800101-8802623

13860 - SPEED/POWER MANIFOLD

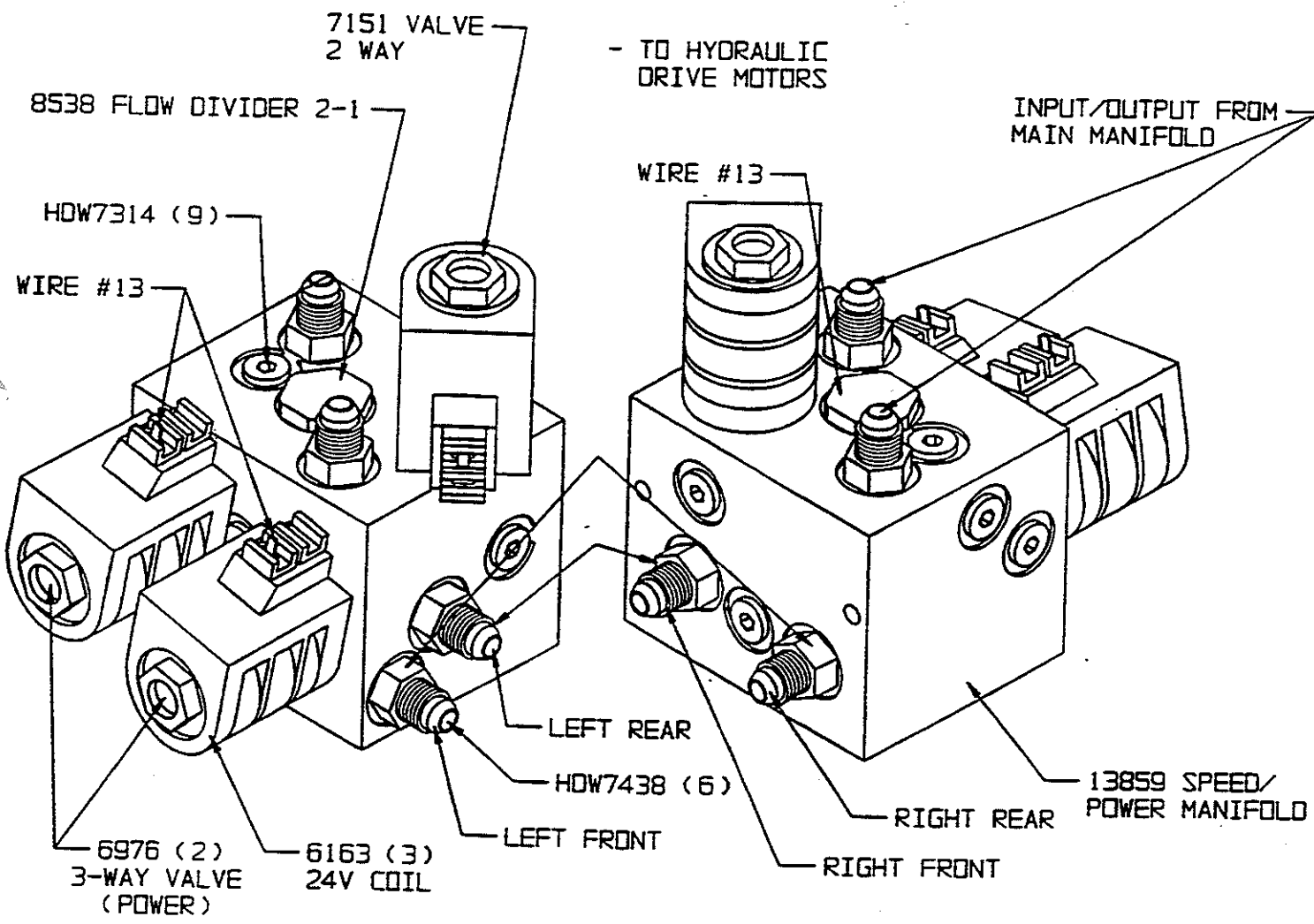

ART567 R1
BM12337
5/6/97

Figure 7-4. 2033ES Speed/Power Manifold

DIODE BOARD

The diode board is located inside the lower control box.

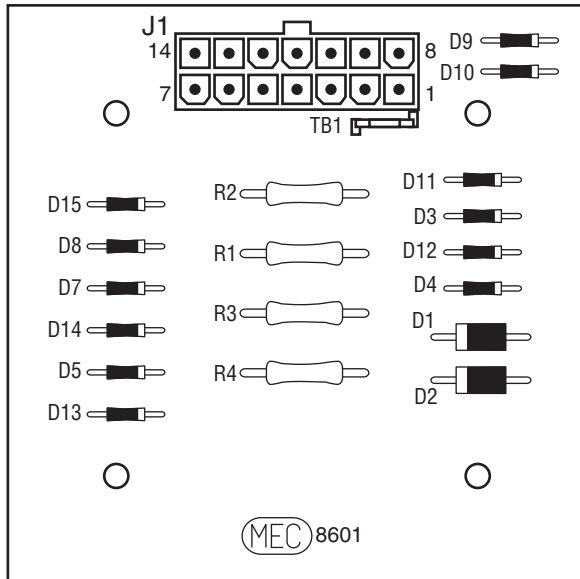

J1 Plug Pin Identification			
PIN #	WIRE #	SIGNAL	FUNCTION
1	10	INPUT	Drive Reverse
2	11	INPUT	Drive Forward
3	19	OUTPUT	Brake, Decel Valve signal
4	8	INPUT	Steer Left
5	18	OUTPUT	Steer signal to Sevcon
6	5	INPUT	Down signal
7	20	OUTPUT	Signal to Motion Alarm(s) (optional)
8	17	OUTPUT	Sevcon & Hour Meter (motor function requested)
9	15	INPUT	Battery Negative
10	7	INPUT	Steer Right
11	4	INPUT	Lift Up
12	2	INPUT	Limit Switch (24V = platform down)
13	3	OUTPUT	Enable, from lower Lift switch
14	21	OUTPUT	To Sevcon (for speed cutback)

ILLUSTRATION No.
ART_2181

SEVCON MOTOR SPEED CONTROLLER

The Sevcon Motor Speed Controller (MC-1) is a microprocessor designed with the express purpose of operating the D/C electric motor at varying speeds. The controller uses Pulse-Width Modulation (PWM) technology on the Ground side of the motor to control motor speed. Out of concern for operator safety and to prevent short-circuiting, the Controller monitors certain circuits for potential abnormalities. When the controller senses a problem it errs to the side of safety and stops all motor operation. The green LED will flash a code indicating the reason for the shutdown.

Refer to the *LED Diagnostics Definitions* and *Sevcon Motor Speed Controller - Connections* on the following pages.

The diagram shows the Sevcon Motor Speed Controller (MC-1) with terminal connections labeled B+, B-, and M2. A green LED is located between the B+ and B- terminals. Below the main unit, a J5 plug is shown with pins 1, 6, 7, and 12 labeled. Lines connect the terminal labels to the corresponding entries in the tables.

Cable Connection Identification	
B+	Battery Positive Cable from 250 AMP Fuse
B-	Negative Battery Cable and GROUND wire (15) connection
M2	Motor Ground (Pulse-Width Modulated [PWM] variable speed control)

J5 Plug Pin Identification		
PIN #	WIRE #	FUNCTION
1	22	B+ power input (power up)
2	17	Lift, Drive or Steer functions input (functions requiring motor)
3	18	Steer Requested (adds additional motor speed for steer)
4	3	Enable Switch signal input
5	21	Speed cut-back (24 Volts = full speed, 0 Volts = creep speed)
6	16	Motor Start Relay signal (GROUND signal to activate Motor Start Relay)
7	41	Lift Valve B- (provides GROUND signal to Lift Valve)
8	none	none
9	14	Accelerator reference signal (3.6 Volts to Potentiometer)
10	none	none
11	none	none
12	none	none

 ILLUSTRATION No.
 ART_2182

LED Diagnostics Definitions (Flash Codes)

LED READING	DIAGNOSIS
LED Steady On	Controller is operational and detects no irregularities on monitored circuits.
LED Off	No power-up <ul style="list-style-type: none"> • No power to pin # 1 • No ground to B- post • LED failure or internal controller fault
2 Flashes	Procedure fault. <ul style="list-style-type: none"> • Enable depressed at power up • Enable depressed for more then 15 seconds without function request • No signal on wire 17 pin # 2 when function requested • No B- to diode board • Failed diode/s • Damaged wire harness • Internal controller fault
3 Flashes	Motor circuit low. Set with unit at rest and is the result of the voltage at M-2 dropping to approximately 4 volts or lower. Possible causes: <ul style="list-style-type: none"> • Short to ground in the motor circuit between the motor contactor and the M-2 terminal
4 Flashes	Motor circuit high. Set with the unit at rest and is the result of the voltage at M-2 terminal rising above 21 volts. Possible causes: <ul style="list-style-type: none"> • Motor contactor points are welded shut
5 Flashes	Motor contactor circuit open. Set when a function is requested but no current can flow through the motor circuit to the M-2 terminal. Possible causes: <ul style="list-style-type: none"> • Blown 200 amp fuse • Malfunctioning motor contactor • Worn motor brushes • Incomplete circuit to the Sevcon pin #6 If the motor and contactor circuits are diagnosed as working properly: <ul style="list-style-type: none"> • Sevcon internal fault

continued...

LED Diagnostics Definitions (continued)

LED READING	DIAGNOSIS
<p>6 Flashes</p>	<p>Accelerator fault. Set with unit at rest, a 6 flash will result in an 80% cutback of motor speed. The Accelerator is the proportional control circuitry for the Sevcon. It works in conjunction with the potentiometer located in the upper control box, which is connected to the joystick handle through a gear arrangement.</p> <p>Measure voltage at terminals 14 and 15 on the platform terminal strip or at the potentiometer plug connection.</p> <ul style="list-style-type: none"> • With the joystick handle in neutral, 3.6 volts should be measured on the accelerator circuit (wire #14) • Voltage proportionally decreases with the travel of the joystick, with 0 volts at full stroke • With the joystick centered, voltages lower than 3.1 or higher than 3.9 will trigger a (6 flash) code
<p>7 Flashes</p>	<p>Battery voltage fault.</p> <ul style="list-style-type: none"> • This includes battery voltage below 12 volts or above 45 volts as measured on pin #1 • This code will disable all functions
<p>8 Flashes</p>	<p>Thermal cutback.</p> <ul style="list-style-type: none"> • Sevcon internal temperatures above 176 degrees F • Will limit motor speed in comparison with over temperature • Resets when cooled
<p>9 Flashes</p>	<p>Battery voltage at or below 18 volts</p> <ul style="list-style-type: none"> • As measured on pin #1 • This code will interrupt or prevent lift function but will allow drive and steer functions <p>When lift is interrupted due to a 9 flash, the electric motor will still run.</p>

Sevcon Motor Speed Controller - Connections

The following two pages describe the connections to the Sevcon Motor Speed Controller with a brief description of their function and the voltage measurements under normal conditions.

Important: Batteries must be fully charged before troubleshooting!

A fully charged battery set on a 24 V DC system will have a nominal voltage of 25.6 V DC

FUNCTION	VOLTAGE READING
PIN 1 – WIRE 22 (WIRE 9 ON EARLY UNITS)	
Battery Positive Input	Switched 5% less than battery voltage <ul style="list-style-type: none"> • Controller power-up and reference point for battery state-of-charge • Green LED indicates controller power-up • Power travels through the upper emergency-stop switch with upper controls selected • 7-Flash code and 9-flash code indicate low voltage at this terminal
Pin 2 Wire 17	
Lift, Drive or Steer functions requested	Motorized function is requested 15%-18% less than battery voltage <ul style="list-style-type: none"> • Controller begins the motor run sequence with this signal but still requires a signal on pin 4 and a change on pin 9 before the motor will operate
Pin 3 Wire 18	
Steer Function Requested	When steering is operated 15%-18% less than battery voltage <ul style="list-style-type: none"> • Adds motor speed to compensate for addition of steer requirement during drive operation • Provides a minimum motor speed for steer requirement when only steer is operated
Pin 4 Wire 3	
Enable signal input	When joystick trigger pulled 5% less than battery voltage. <ul style="list-style-type: none"> • Motor will not start without this input • A signal here longer then 15 seconds without a signal on pin-2 or pin-3 will result in a 2-flash code failure
Pin 5 Wire 21	
Speed cut-back signal from limit switch or Lift circuit	Full speed: 24 V DC Creep speed: 0 V DC. <ul style="list-style-type: none"> • Speed cut-back is the elevated drive speed



Sevcon Motor Speed Controller - Connections (continued)

FUNCTION	VOLTAGE READING
PIN 6 – WIRE 16	
Motor Start Relay ground signal	<p>Idle: 24 V DC</p> <p>When function requested: 0 V DC</p> <ul style="list-style-type: none"> • This is how the Controller maintains control over the motor circuit • Sevcon controls the Motor Start Relay function ground signal • Will not operate the motor start relay when 2, 3, 4 & 7 flash codes occur
PIN 7 – WIRE 41	
Ground signal to Lift solenoid valve	<p>0 volts</p> <p>No ground presence until lift is requested</p> <ul style="list-style-type: none"> • By providing the ground signal, lift function can be prevented anytime battery voltage falls below 18 volts. This will result in a 9 flash code
PIN 9 – WIRE 14	
Accelerator reference signal to the potentiometer (upper control box)	<p>From 3.5 V DC with joystick in the neutral to 0 V DC at full stroke</p> <ul style="list-style-type: none"> • Controller uses this circuit to monitor joystick input after pins 2 & 4 energize • Controls motor speed in reference to the voltage on this circuit • Voltages above 4.0 V DC or below 3.0 V DC will result in a 6 flash code
POST B+	
Battery positive cable from 200 amp fuse	<p>Full battery voltage</p> <ul style="list-style-type: none"> • No real diagnostic value
POST B–	
Battery positive cable from 200 amp fuse	<p>Battery ground cable connection</p> <p>Ground path for motor operation</p> <ul style="list-style-type: none"> • All system ground wires (wire #s 15 & 15A) terminate here • Best place to connect ground lead from multi-meter while troubleshooting
POST M-2	
PWM controlled motor ground	<p>Idle: 12 V DC – 13 V DC</p> <p>During operation, between 5 V DC & 24 V DC</p> <ul style="list-style-type: none"> • 12 – 13 volts is reference voltage used by the controller to monitor motor circuit irregularities at idle • 0 volts at idle = 3 flash code • Above 20 volts at idle = 4 flash code • No voltage change after Motor Start Relay signal = 5 flash code