



SERVICE AND PARTS MANUAL

3072ES / 3772ES / 3772ES HD

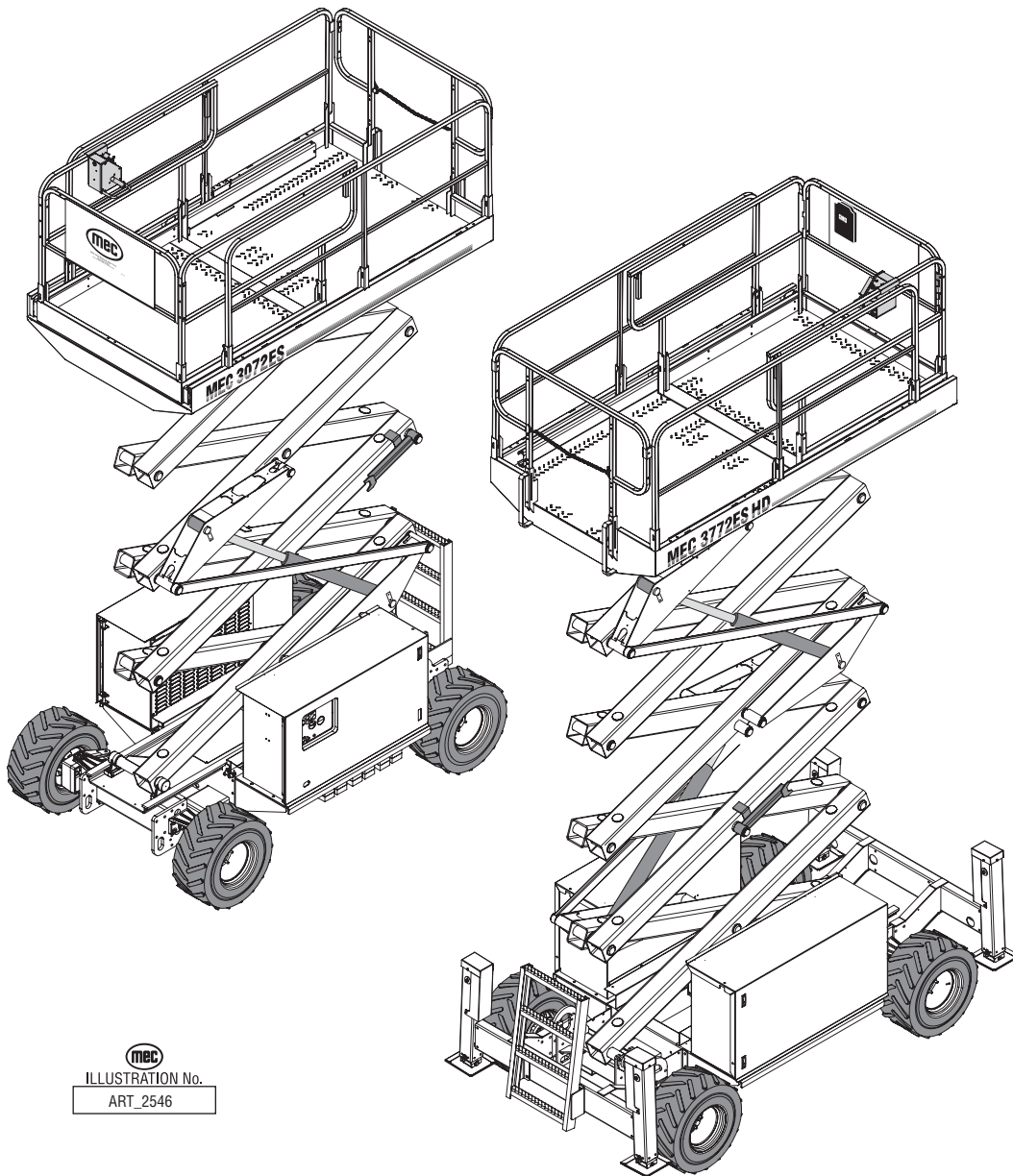



ILLUSTRATION No.
ART_2546

Serial Number Range
11211001 - Present

Part # 91778 R1
October 2008

Revision History

Original Release Date: June 2008

Revision: October 2008

Page	Reason for Update
Section 5	
5-2	Update table - ORF3=.067 - ORF4=.067 - ORF6=.042
5-3	Update hydraulic schematic
5-8	Update electric schematic
Parts Table of Contents	
All	Update Table of Contents
Section C	
C-2	Update illustration
C-3	Update parts list
C-4	Update illustration
C-5	Update parts list
C-6	Update illustration
C-7	Update parts list
C-8	Update illustration
C-9	Update parts list
C-10	Update illustration
C-11	Update parts list
C-12	Update illustration
C-13	Update parts list
C-14	Update illustration
C-15	Update parts list
C-16	Update illustration
C-17	Update parts list
Section E	
E-14	Update illustration
E-19	Update parts list
E-21	Update parts list
E-23	Update parts list
Part Number Index	
All	New Feature



Aerial Platform Sales Corp.

1775 Park Street, Suite 77 • Selma, CA 93662 USA
Ph: 1-800-387-4575 • 559-891-2488 • Fax: 559-891-2448

E-mail: info@mecawp.com • Web: www.mecawp.com

Table of Contents

Service Manual

INTRODUCTION	I
General Safety Tips	III
Hydraulic System	IV
Electrical System	IV
Total System	IV
Primary Machine Components	V
Primary Machine Components: Compartments	VI
Primary Machine Components Locator	VII
Specifications: ANSI Models	IX
Specifications: CE Models	IX
LUBRICATION	X

SECTION 1

HYDRAULICS	1-1
Hydraulic Fluid	1-2
Hydraulic System components	1-4
Wheel Drive	1-4
Parking Brake and Towing Circuit	1-11
Emergency Systems And Procedures	1-12
Steering Circuit	1-13
Platform Lift Circuit	1-14
Optional Outriggers	1-16
Cylinder Repair	1-17
Hydraulic Manifold	1-20

Table of Contents

SECTION 2

ELECTRICAL SYSTEM	2-1
Electrical System - General	2-2
Diagnostic LED	2-2
Battery Charge Indicator	2-2
Master Disconnect Switch	2-2
Deutsch Connectors	2-3
Batteries	2-4
Battery Replacement	2-6
Battery Charger	2-7
Controls	2-10
Lower Controls	2-10
Upper Controls	2-11
Alarms and Switches	2-12
Limit Switch	2-12
Continuity Checks	2-14
Motor Controller	2-16

SECTION 3

MECHANICAL COMPONENTS	3-1
Torque Specifications	3-2
Base / Undercarriage	3-3
Hoses and Cables	3-3
Raising the Machine	3-4
Tires/Wheels	3-5
Changing Tires/Wheels	3-5
Drive Motors	3-6
Front Drive Motors	3-6
Rear Drive Motor with Brakes	3-6
Steer Cylinder	3-7
Platform Removal	3-8
Lift Cylinder Removal and Installation	3-9
Scissor Beam Assembly	3-10
Outrigger Function	3-11

Table of Contents

SECTION 4

TROUBLESHOOTING	4-1
General Troubleshooting Tips	4-2
Electrical System Troubleshooting	4-4
EZ-Cal Scan Tool	4-8
EZ-Cal Adjustment	4-14
EZ-Cal Setup	4-16
EZ-Cal Diagnostics	4-17
EZ-Cal Outrigger Test Mode	4-18
Retrieve Mode And Help Messages From The Ez-Cal	4-21
EZ-Cal HELP Messages	4-24
Trouble Table	4-30
Hydraulic Pressure Adjustment Procedures	4-35
Troubleshooting Battery Charger	4-38

SECTION 5

SCHEMATICS	5-1
Hydraulic Schematic	5-2
Main Hydraulic Manifold	5-4
Main Relief Hydraulic Manifold	5-5
Optional Outriggers Hydraulic Manifold	5-5
Electric System	5-6
Electric Schematics: Upper Controls, Early Models	5-6
Electric Schematics: Upper Controls, Current Models	5-7
Electric Schematics: Base	5-8
P600 Motor Control Module	5-9
GP400 Matrix Module	5-10
Matrix Module Controller	5-11

Table of Contents

Parts Manual

SECTION A: CONTROL BOXES

SECTION B: PLATFORM AND RAILS

SECTION C: SCISSORS

SECTION D: AXLES

SECTION E: HYDRAULICS

SECTION F: BASE

SECTION G: DECALS

INTRODUCTION

This manual consists of a *Service Section* and an illustrated *Parts Section*.

The *Service Section* of this manual is designed to provide you, the customer, with the instructions needed to properly maintain the MEC self-propelled scissor lift. When used in conjunction with the illustrated *Parts Section* and the *Operators Manual* (provided separately), this manual will assist you in making necessary adjustments and repairs, and identifying and ordering the correct replacement parts.

All parts represented here are manufactured and supplied in accordance with MEC's quality standards. We recommend that you use Genuine MEC parts to insure proper operation and reliable performance.

To obtain maximum benefits from your MEC aerial work platform, always follow the proper operating and maintenance procedures. Only trained authorized personnel should be allowed to operate or service this machine. Service personnel should read and study the *Operator's Manual* and *Service and Parts Manual* in order to gain a thorough understanding of the unit prior to making any repairs.

To help you recognize important safety information, we have identified warnings and instructions that directly impact on safety with the following signals:



“DANGER” INDICATES AN IMMINENTLY HAZARDOUS SITUATION WHICH, IF NOT AVOIDED, WILL RESULT IN DEATH OR SERIOUS INJURY. THIS SIGNAL WORD IS LIMITED TO THE MOST EXTREME SITUATIONS.



“WARNING” INDICATES A POTENTIALLY HAZARDOUS SITUATION WHICH, IF NOT AVOIDED, COULD RESULT IN DEATH OR SERIOUS INJURY.



“CAUTION” with alert symbol indicates a potentially hazardous situation which, if not avoided, may result in minor or moderate injury. It may also be used to alert against unsafe practices.



“CAUTION” without alert symbol indicates a situation which, if not avoided, may result in damage to the machine.

NOTE: The best method to protect yourself and others from injury or death is to use common sense. If you are unsure of any operation, don't start until you are satisfied that it is safe to proceed and have discussed the situation with your supervisor.

Service personnel and machine operators must understand and comply with all warnings and instructional decals on the body of the machine, at the lower controls, and the upper controls.



MODIFICATIONS OF THIS MACHINE FROM THE ORIGINAL DESIGN AND SPECIFICATIONS WITHOUT WRITTEN PERMISSION FROM MEC ARE STRICTLY FORBIDDEN. A MODIFICATION MAY COMPROMISE THE SAFETY OF THE MACHINE, SUBJECTING OPERATOR(S) TO SERIOUS INJURY OR DEATH.

MEC's policies and procedures demonstrate our commitment to Quality and our relentless ongoing efforts towards Continuous Improvement, due to which product specifications are subject to change without notice.

Any procedures not found within this manual must be evaluated by the individual to assure oneself that they are "proper and safe."

Your MEC aerial work platform has been designed, built, and tested to provide many years of safe, dependable service. Only trained, authorized personnel should be allowed to operate or service the machine.

MEC, as manufacturer, has no direct control over machine application and operation. Proper safety practices are the responsibility of the user and all operating personnel.

If There Is A Question On Application And/Or Operation Contact:



Aerial Platform Sales Corp.

1775 Park Street, Suite 77 • Selma, CA 93662 USA

Ph: 1-800-387-4575 • 559-891-2488 • Fax: 559-891-2448

www.mecawp.com



GENERAL SAFETY TIPS

Regular inspection and conscientious maintenance is the key to efficient economical operation of your MEC aerial work platform. It will help to assure that your equipment will perform satisfactorily with a minimum of service and repair.

The actual operating environment of the machine governs the inspection schedule. Correct lubrication is an essential part of preventative maintenance to minimize wear on working parts and ensure against premature failure. By maintaining correct lubrication, the possibility of mechanical failure and resulting downtime is reduced to a minimum.



NEVER PERFORM SERVICE ON THE MACHINE WITH THE PLATFORM ELEVATED WITHOUT FIRST BLOCKING THE SCISSOR ASSEMBLY USING THE MAINTENANCE LOCK!

- Block the scissor assembly using the maintenance lock if the machine is in the elevated/extended position.
- Never leave hydraulic components or hoses open. They must be protected from contamination (including rain) at all times.
- Never open a hydraulic system when there are contaminants in the air.
- Always clean the surrounding area before opening hydraulic systems.
- Use only recommended lubricants. Improper lubricants or incompatible lubricants may be as harmful as no lubrication.
- Watch for makeshift “fixes” which can jeopardize safety as well as lead to more costly repair.

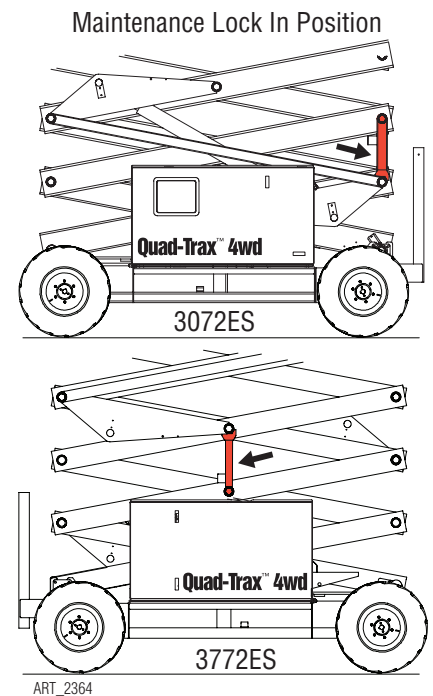

Hydraulic System



HYDRAULIC FLUID UNDER PRESSURE CAN PENETRATE AND BURN SKIN, DAMAGE EYES, AND CAN CAUSE SERIOUS INJURY, BLINDNESS, AND EVEN DEATH. CORRECT LEAKS IMMEDIATELY.



Hydraulic fluid leaks under pressure may not always be visible. Check for pin hole leaks with a piece of cardboard, not your hand.

Electrical System



Prevent damage to battery and/or electrical system;

- **Always disconnect the negative battery cable first.**
- **Always connect the positive battery cable first.**

If contact is made between the positive side of the battery and a metal surface on the machine when the negative cable is installed a spark will occur. This can cause damage to the electrical system, battery explosion, and personal injury.

Total System



Failure to perform preventive maintenance at recommended intervals may result in the unit being operated with a defect that could result in injury or death of the operator.

Immediately report to your supervisor any Defect or malfunction. Any defect shall be repaired prior to continued use of the aerial work platform.

Inspection and maintenance should be performed by qualified personnel familiar with the equipment.

PRIMARY MACHINE COMPONENTS

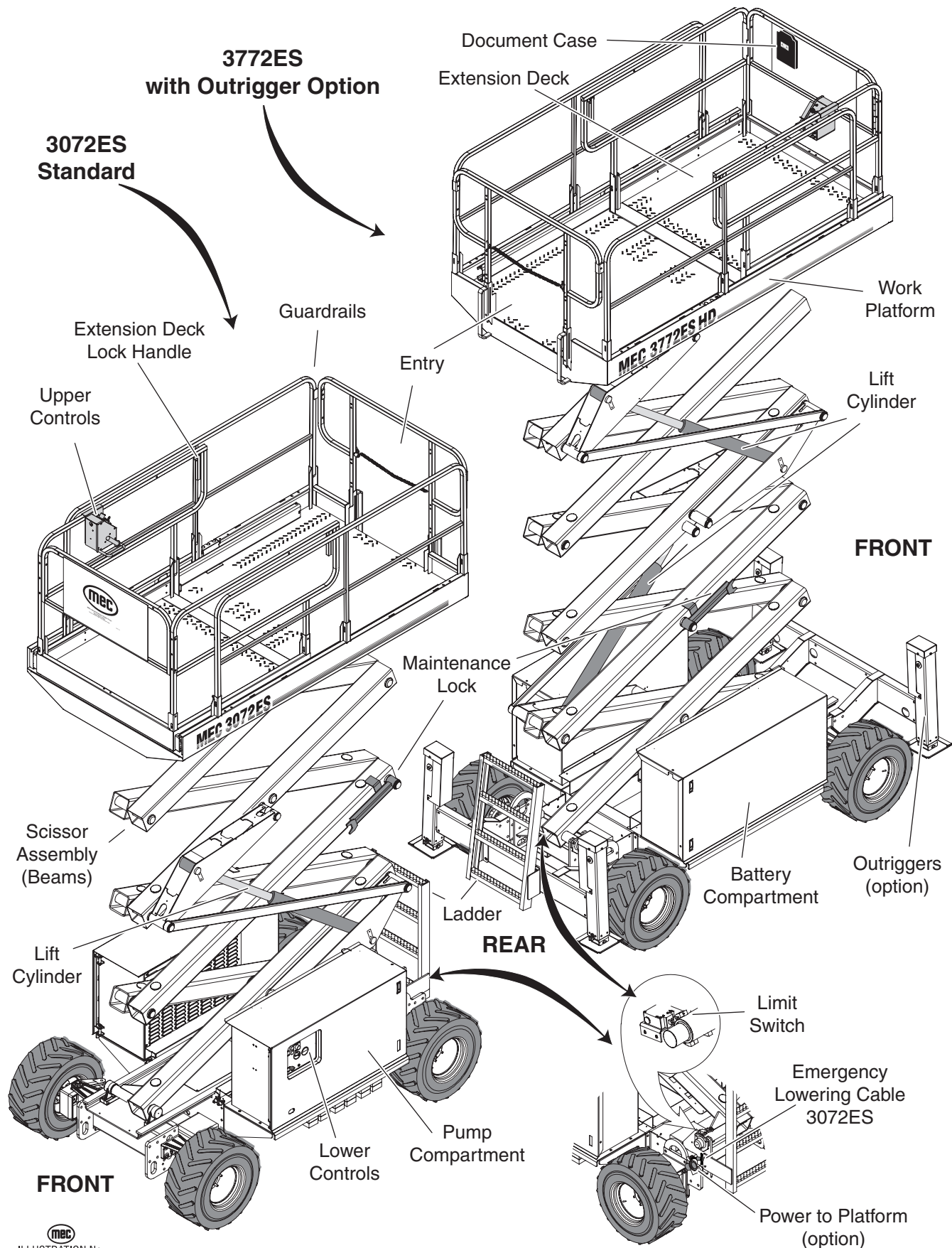

mecc
ILLUSTRATION No.
ART_2345 R1



PRIMARY MACHINE COMPONENTS: COMPARTMENTS

CONTROL MODULE

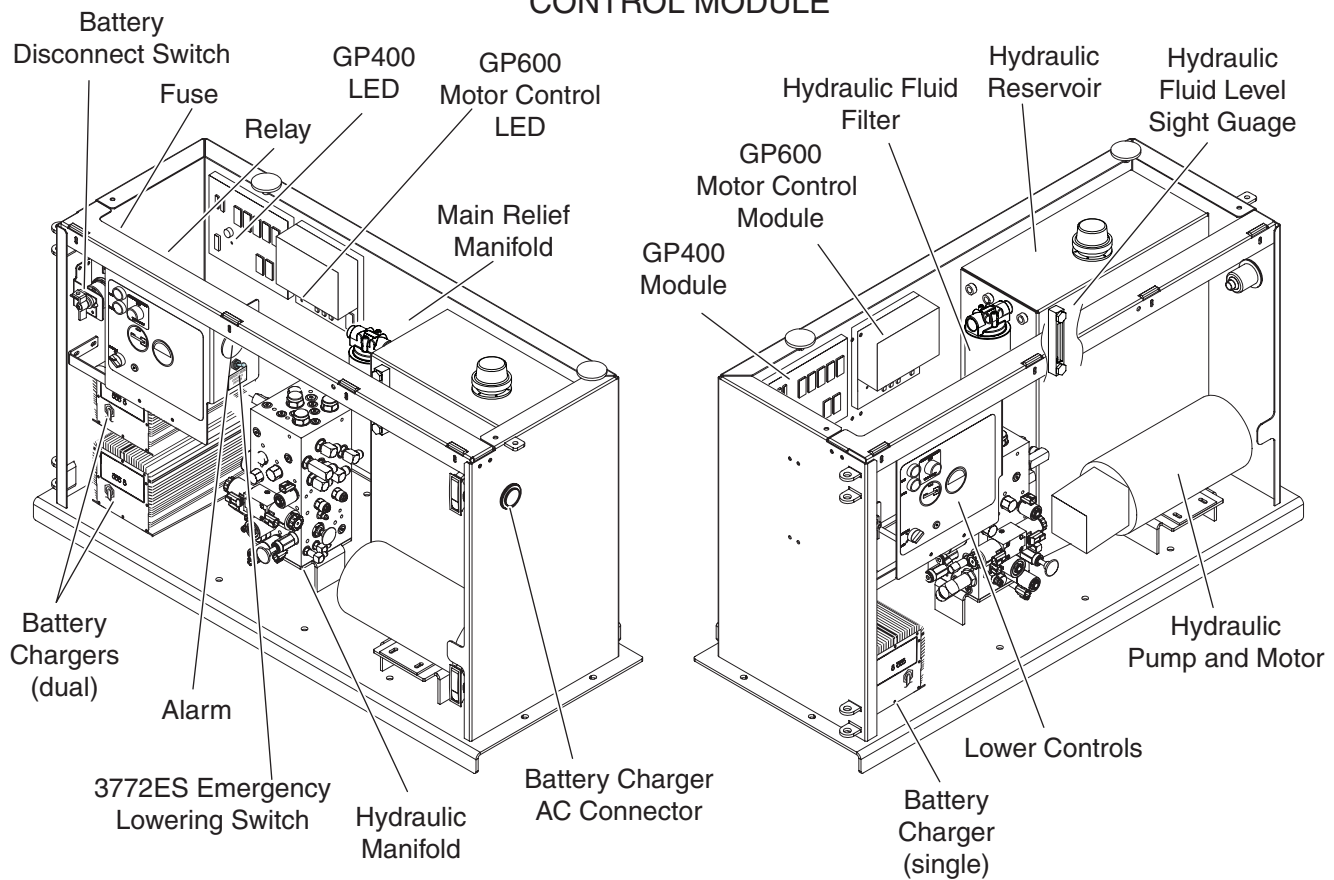

POWER MODULE

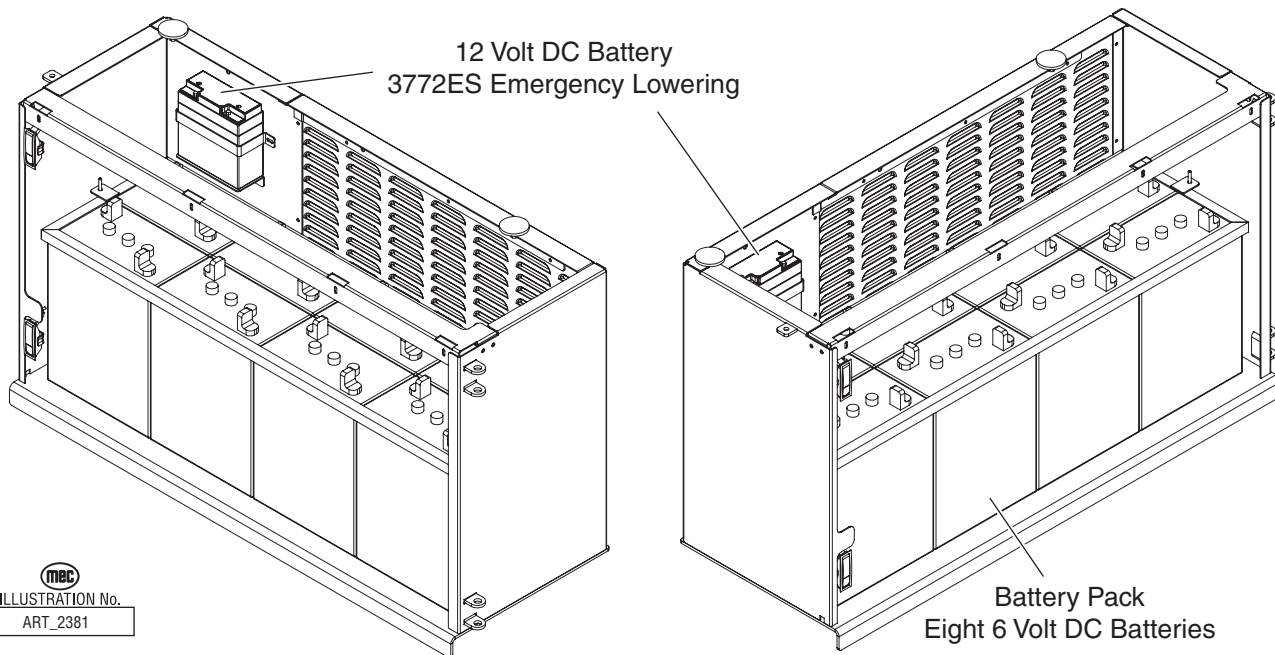

MEC
ILLUSTRATION No.
ART_2381

PRIMARY MACHINE COMPONENTS LOCATOR

Component	Service Section	Parts Section	Component	Service Section	Parts Section
Platform Assembly			Control Module		
Upper Controls	2 4 5	A F	Lower Controls	2 3 4 5	A F
Deck and Rails	3	B	Hydraulic Manifold	1 3 4 5	E F
Chain Closure		B	Hydraulic Pump	1 3 4 5	F
Optional Gate		B	Hydraulic reservoir	intro 1	F
Extension Deck		B	Hydraulic Filter	intro 1	F
Control Terminal Strip		B	Parking Brake Release	1	E F
Horn (optional)	2	A B	Emergency Lowering	1	E F
			Battery Disconnect	2 3 4 5	F
Lift Assembly			Battery Charger	intro 2 4	F
Beams	intro 3	C	Outrigger Manifold	1 3 4 5	E F
Maintenance Lock	intro	C			
Lift Cylinders	1 3 4 5	C E			
Limit Switch	2 4	C			
Base Assembly			Electronic Control Modules		
Front Drive Motors	intro 1 3 4 5	D E F	GP600 Motor Control	intro 2 4	F
R Drive Motors w/Brakes	intro 1 3 4 5	D E F	GP400 Module	intro 2 4	F
Steering Components	1 3	C E F	GP400 Matrix Module	intro 2 4	A
Steering Components	1 3 4 5	C E F			
Wheels & Tires	intro 3	F			
Hubs	intro 1 3	D F			
Slide Block	intro 3	C			
Emergency Lowering	1 2	E F			
Hoses & Cables	1 2 3	E F			
Outrigger (Option)	1 3 4 5	E F			
Power to Platform		B F			
Power Module					
Battery Pack	intro	F			
E-Lower Battery	intro	F			

SPECIFICATIONS: ANSI MODELS

	3072ES		3772ES		3772ES HD		
Working Height*	36.0 ft*	11.14 m*	43 ft*	13.28 m*	43 ft*	13.28 m*	
Platform Height	30.0 ft	9.14 m	37 ft	11.28 m	37 ft	11.28 m	
Platform Entry Height	54 in	1.4 m	61 in	1.5 m	61 in	1.5 m	
Stowed Height							
Rails Up	108.5 in	2.75 m	105.25 in	2.67 m	105.25 in	2.67 m	
Rails Folded Down	78.5 in	1.99 m	74 in	1.85 m	74 in	1.85 m	
Maximum Number of Occupants	3	3	3	3	3	3	
Lift Capacity (Evenly Distributed)	1,000 lb	454 kg	750 lb	340 kg	1,000 lb	454 kg	
Roll-out Deck Capacity	400 lb	181 kg	400 lb	181 kg	400 lb	181 kg	
Platform Dimensions							
With Deck Extended (inside rails)	153.5 in	3.90 m	158 in	4.01 m	158 in	4.01 m	
With Deck Retracted (inside rails)	107 in	2.72 m	110 in	2.79 m	110 in	2.79 m	
Platform Width (inside rails)	56 in	1.44 m	60 in	1.52 m	60 in	1.52 m	
Guardrail Height	44.7 in	1.14 m	43.5 in	1.10 m	43.5 in	1.10 m	
Toeboard Height	6.0 in	15.0 cm	6.0 in	15.0 cm	6.0 in	15.0 cm	
Extension Deck Length	46.5 in	1.18 m	48 in	1.22 m	48 in	1.22 m	
Overall Length	117.25 in	2.98 m	117.25 in	2.98 m	140 in	3.56 m	
Overall Width	72 in	1.83 m	72 in	1.83 m	73.25 in	1.86 m	
Wheel Base	86.0 in	2.18 m	86.0 in	2.18 m	86.0 in	2.18 m	
Wheel Track	60.5 in	1.54 m	60.5 in	1.54 m	60.5 in	1.54 m	
Turning Radius							
Inside	73.25 in	1.86 m	73.25 in	1.86 m	73.25 in	1.86 m	
Outside	170.5 in	4.33 m	170.5 in	4.33 m	170.5 in	4.33 m	
Ground Clearance	9.5 in	24 cm	9.5 in	24 cm	9.5 in	24 cm	
Machine Weight** (Unloaded) (Approx.)	7062 lb**	3203 kg**	7995 lb**	3626 kg**	8585 lb**	3894 kg**	
Drive System (Proportional)	2 Wheel Drive Standard, 4 Wheel Drive Option						
Drive Speed (Platform Elevated)	0 – 0.4 mph	0 – 0.6 km/h	0 – 0.4 mph	0 – 0.6 km/h	0 – 0.4 mph	0 – 0.6 km/h	
Drive Speed (Platform Lowered)	0 – 3.0 mph	0 – 4.8 km/hr	0 – 3.0 mph	0 – 4.8 km/hr	0 – 3.0 mph	0 – 4.8 km/hr	
Lift/Lower Speed (Approx.)	36 sec / 28 sec	36 sec / 28 sec	40 sec / 28 sec	40 sec / 28 sec	40 sec / 28 sec	40 sec / 28 sec	
Gradeability	45% / 24.2°	45% / 24.2°	40% / 21.5°	40% / 21.5°	40% / 21.5°	40% / 21.5°	
Ground Pressure/Wheel (Maximum)	–	–	100 psi	7.0 kg/cm ²	–	–	
Wheel Load	–	–	2,987 lb	1355 kg	–	–	
Tire Size-Standard	26.0-12D / 380 NHS						
Tire Pressure, 12 Ply Pneumatic			60 psi	4.14 bar			
Non-marking 12 Ply (Option)			Foam-Filled	Foam-Filled			
Wheel Lug Nut Torque			75-85 ft/lb	102-115 Nm			
Hydraulic Pressure	Main System			3000 psi	207 bar		
	Lift System			2500 psi	172 bar		
	Steer			2000 psi	138 bar		
Hydraulic Fluid Capacity			23 GAL	87 liters			
Power System – Voltage	48 Volts DC						
Batteries	Eight 6 Volt DC 350 amp hour industrial, deep cycle						
Single Battery Charger	Input	120 Volt AC, 50.60 Hz, 18 Amp—240 Volt AC, 50.60 Hz, 9 Amp					
	Output	48 Volt DC, 32 Amp, 1500 W, Timed Shutoff					
Dual Battery Chargers	Input	120 Volt AC, 50.60 Hz, 18 Amp—240 Volt AC, 50.60 Hz, 9 Amp					
	Output	24 Volt DC, 32 Amp, 700 W, Timed Shutoff					
Electric Motor	8 h.p. (6 kW): 3600 rpm						
Brakes	Multi-disc / Dual Rear Wheel						

Meets requirements of ANSI A92.6-2006 Section 4.

*Working height adds 6 feet (2 m) to platform height.

**Weight may increase with certain options or country standards.

SPECIFICATIONS: CE MODELS

	3072ES		3772ES		3772ES HD	
Working Height*	36.6 ft*	11.14 m*	43.6 ft*	13.28 m*	43.6 ft*	13.28 m*
Platform Height	30.0 ft	9.14 m	37 ft	11.28 m	37 ft	11.28 m
Platform Entry Height	54 in	1.4 m	61 in	1.5 m	61 in	1.5 m
Stowed Height						
Rails Up	108.5 in	2.75 m	105.25 in	2.67 m	105.25 in	2.67 m
Rails Folded Down	78.5 in	1.99 m	74 in	1.85 m	74 in	1.85 m
Maximum Occupants						
0 m/s wind	3	3	2	2	3	3
12.5 m/s wind	2	2	2	2	3	3
Lift Capacity (Evenly Distributed)	1,000 lb	454 kg	750 lb	340 kg	1,000 lb	454 kg
Roll-out Deck Capacity	400 lb	181 kg	400 lb	181 kg	400 lb	181 kg
Maximum Operating Inclination	3°		3° up to 9.1 m (30 ft.) 1.5° up to 11.28 m (37 ft.)		3° up to 9.1 m (30 ft.) 1.5° up to 11.28 m (37 ft.)	
Platform Dimensions						
With Deck Extended (inside rails)	153.5 in	3.90 m	158 in	4.01 m	158 in	4.01 m
With Deck Retracted (inside rails)	107 in	2.72 m	110 in	2.79 m	110 in	2.79 m
Platform Width (inside rails)	56 in	1.44 m	60 in	1.52 m	60 in	1.52 m
Guardrail Height	44.7 in	1.14 m	43.5 in	1.10 m	43.5 in	1.10 m
Toeboard Height	6.0 in	15.0 cm	6.0 in	15.0 cm	6.0 in	15.0 cm
Extension Deck Length	46.5 in	1.18 m	48 in	1.22 m	48 in	1.22 m
Overall Length	117.25 in	2.98 m	117.25 in	2.98 m	140 in	3.56 m
Overall Width	72 in	1.83 m	72 in	1.83 m	73.25 in	1.86 m
Wheel Base	86.0 in	2.18 m	86.0 in	2.18 m	86.0 in	2.18 m
Wheel Track	60.5 in	1.54 m	60.5 in	1.54 m	60.5 in	1.54 m
Turning Radius						
Inside	73.25 in	1.86 m	73.25 in	1.86 m	73.25 in	1.86 m
Outside	170.5 in	4.33 m	170.5 in	4.33 m	170.5 in	4.33 m
Ground Clearance	9.5 in	24 cm	9.5 in	24 cm	9.5 in	24 cm
Machine Weight** (Unloaded) (Approx.)	7868 lb**	3569 kg**	8340 lb**	3783 kg**	8950 lb**	4060 kg**
Drive System (Proportional)	2 Wheel Drive Standard, 4 Wheel Drive Option					
Drive Speed (Platform Elevated)	0 – 0.4 mph	0 – 0.6 km/h	0 – 0.4 mph	0 – 0.6 km/h	0 – 0.4 mph	0 – 0.6 km/h
Drive Speed (Platform Lowered)	0 – 3.0 mph	0 – 4.8 km/hr	0 – 3.0 mph	0 – 4.8 km/hr	0 – 3.0 mph	0 – 4.8 km/hr
Lift/Lower Speed (Approx.)	36 sec / 28 sec	36 sec / 28 sec	40 sec / 28 sec	40 sec / 28 sec	40 sec / 28 sec	40 sec / 28 sec
Gradeability	45% / 24.2°	45% / 24.2°	40% / 21.5°	40% / 21.5°	40% / 21.5°	40% / 21.5°
Wind Speed (Maximum)	28 mph	12.5 m/sec	28 mph	12.5 m/sec	28 mph	12.5 m/sec
Ground Pressure/Wheel (Maximum)			100 psi	7.0 kg/cm ²		
Wheel Load			–	–		
Tire Size-Standard	26.0-12D / 380 NHS					
Non-marking 12 Ply			Foam-Filled	Foam-Filled		
Wheel Lug Nut Torque			75-85 ft/lb	102-115 Nm		
Hydraulic Pressure	Main System		3000 psi	207 bar		
	Lift System		2500 psi	172 bar		
	Steer		1500 psi	103 bar		
Hydraulic Fluid Capacity			23 GAL	87 liters		
Power System – Voltage	48 Volts DC					
Batteries	Eight 6 Volt DC 350 amp hour industrial, deep cycle					
Single Battery Charger	Input		120 Volt AC, 50.60 Hz, 18 Amp—240 Volt AC, 50.60 Hz, 9 Amp			
	Output		48 Volt DC, 32 Amp, 1500 W, Timed Shutoff			
Dual Battery Chargers	Input		120 Volt AC, 50.60 Hz, 18 Amp—240 Volt AC, 50.60 Hz, 9 Amp			
	Output		24 Volt DC, 32 Amp, 700 W, Timed Shutoff			
Electric Motor	8 h.p. (6 kW): 3600 rpm					
Brakes	Multi-disc / Dual Rear Wheel					

Meets requirements of CE.

*Metric equivalent of working height adds 2 m (6.6 ft.) to platform height.

**Weight may increase with certain options or country standards.



LUBRICATION

NO.	ITEM	SPECIFICATION	FREQUENCY
1	Hydraulic Reservoir	With platform in the stowed position, fill to the middle of the sight gauge with ISO32 or equivalent.	Check daily. Change YEARLY or every 1,000 HOURS, whichever occurs first.
2	Hydraulic Filter	Filter Element	Normal usage: change EVERY SIX MONTHS or 500 HOURS, whichever occurs first. Severe usage: change EVERY THREE MONTHS or 300 HOURS, whichever occurs first.
3	Front Hubs Steering Pivots	Lithium N.L.G. #2 EP Purge old grease	MONTHLY or EVERY 25 HOURS, Whichever Occurs First
4	Slide Block	Lithium N.L.G. #2 EP Purge old grease	MONTHLY or EVERY 25 HOURS, Whichever Occurs First
5	Fixed	Lithium N.L.G. #2 EP Purge old grease	MONTHLY or EVERY 25 HOURS, Whichever Occurs First

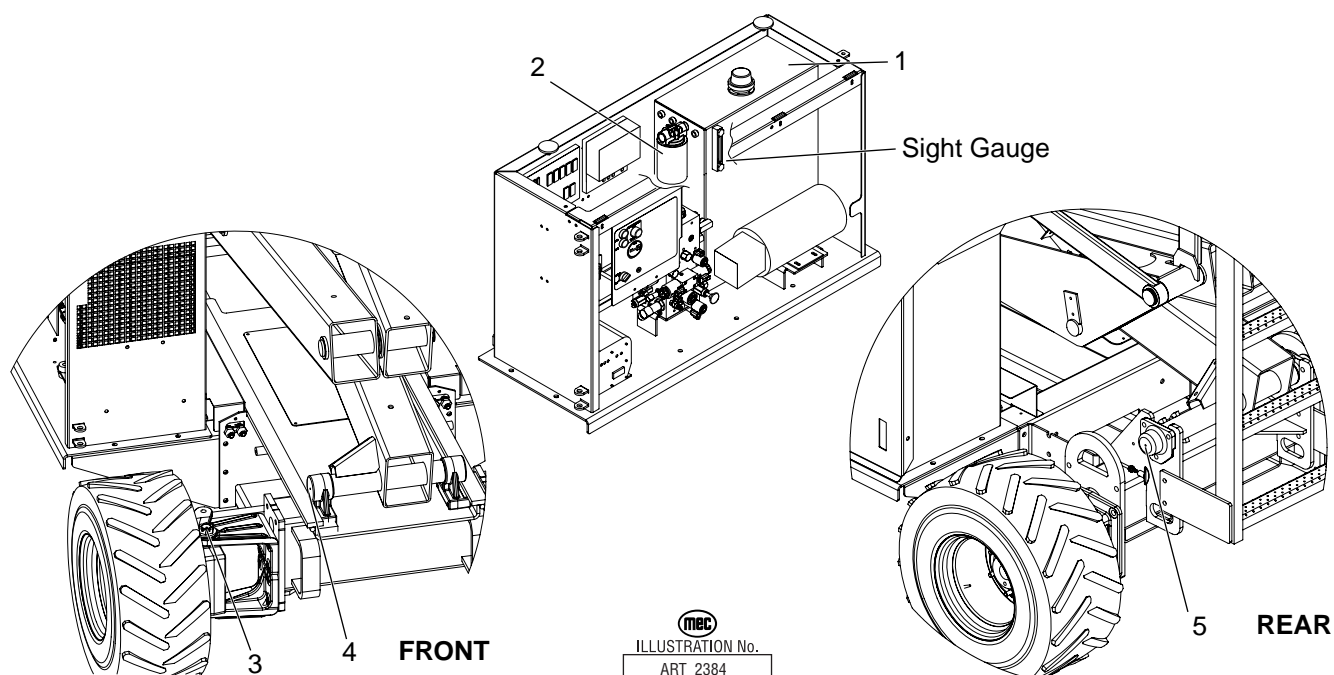



SECTION 1

HYDRAULICS

Hydraulic Fluid	1-2
Hydraulic System components	1-4
Wheel Drive	1-4
Parking Brake and Towing Circuit	1-11
Emergency Systems And Procedures	1-12
Steering Circuit	1-13
Platform Lift Circuit	1-14
Optional Outriggers	1-16
Cylinder Repair	1-17
Hydraulic Manifold	1-20

HYDRAULIC FLUID

Handling Precautions



PERSONS IN REGULAR CONTACT WITH MINERAL-BASED HYDRAULIC FLUID NEED TO BE AWARE OF THE IMPORTANCE OF THOROUGH HYGIENE, AND THE PROPER METHODS FOR HANDLING MINERAL OILS IN ORDER TO AVOID POTENTIAL HAZARDS TO HEALTH.

HYDRAULIC FLUID UNDER PRESSURE CAN PENETRATE AND BURN SKIN, DAMAGE EYES, AND CAN CAUSE SERIOUS INJURY OR BLINDNESS.

FLUID LEAKS UNDER PRESSURE MAY NOT ALWAYS BE VISIBLE.

If mineral-based hydraulic fluid is **SPLASHED INTO THE EYES**, it must be **WASHED OUT THOROUGHLY** using abundant quantities of water. If irritation persists, medical advice should be sought.

Hydraulic Fluid Recommendations

MEC recommends the use of **ISO32** hydraulic fluid or equivalent.

System Flushing Procedure

1. With platform fully lowered, drain hydraulic fluid from hydraulic reservoir into a clean, empty container. Dispose of fluid in accordance with local environmental guidelines.
2. When the hydraulic reservoir is empty, remove suction strainer and hoses.
3. Remove the return line on the hydraulic reservoir.
4. Remove the bypass filter and hose.
5. Flush the hoses with clean hydraulic fluid.
6. Discard old bypass filter element and replace.
7. Flush out the reservoir with hoses removed.
8. Reinstall all hoses removed in the previous steps.
9. Fill hydraulic reservoir with filtered, fresh hydraulic fluid (refer to Lubrication Chart).
10. Loosen output hose fittings at pump to flood with hydraulic fluid. Tighten fittings.
11. Briefly operate all functions. Two or three lift cycles may be necessary to purge all air from lift cylinder(s).
12. When the above procedures have been completed, fill hydraulic reservoir (refer to Lubrication Chart).
13. Check all leaks and correct as necessary. Machine is now ready to be placed into operation.

NOTE: Avoid mixing petroleum and synthetic base fluids. It is not advisable to mix fluids of different brands or types, except as recommended.



Beware of hot fluid. Contact with hot fluid may cause severe burns.

HYDRAULIC SYSTEM COMPONENTS

Hydraulic Reservoir Assembly

This consists of the reservoir, a filler cap with breather, a drain plug, a sight gauge, and a bypass filter with a 10 micron filter element.

Perform the following weekly:

- Check reservoir for signs of leakage.

Hydraulic Filter

All machines are produced with a filter. It is a 10 micron spin-on, bypassing filter. When the filter is clogged, hydraulic flow bypasses the filter element.

Perform the following every six (6) months or 500 hours:

The filter element must be changed. Extremely dirty conditions may require that the filter be replaced more often.

Hydraulic Pump

Note: Refer to *Hydraulic Manifold and Relief Pressure Adjustment Procedure*. Refer to *Section 3* for Remove and Replace instructions.

An electric motor drives the fixed displacement, gear pump. The pump provides hydraulic fluid flow to operate the machine functions at 8.0 g.p.m. (30.28 l.p.m.) at 3000 r.p.m. There are no adjustments on the pump. The pump provides power for the lift, drive, brake and steering functions.

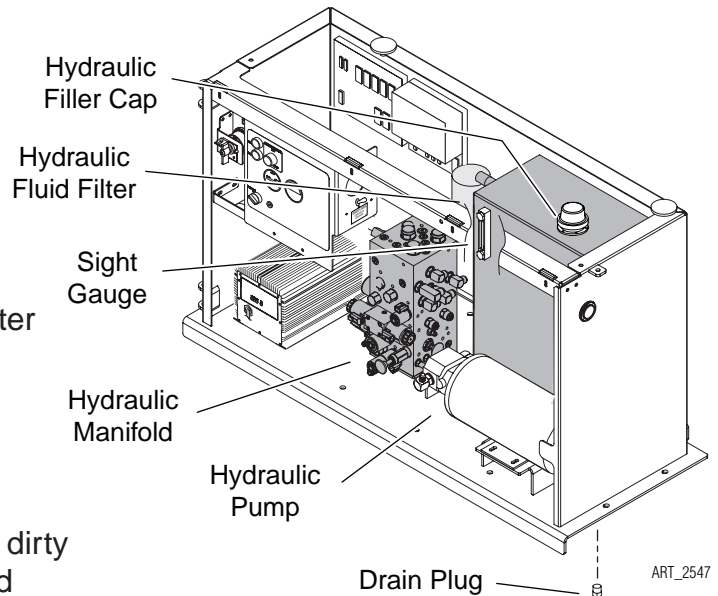

WHEEL DRIVE

Note: Refer to *Section 3* for Remove and Replace instructions.

There are four (4) hydraulic, fixed-displacement gear wheel motors to provide power to all four wheels [two (2) front and two (2) rear].

Dynamic Braking Circuit

The two rear wheel motors have integral brakes that are spring held. Hydraulic pressure developed in the drive circuit, during drive mode, releases the brakes. A fixed orifice in the brake circuit controls the deceleration rate and initiates a smooth stop.

Front Wheel Motors (DT-701)

Housing and Shaft Disassembly

1. Remove all shaft related components from the shaft. Secure the motor housing in a vise.
 - Remove the retaining ring from the groove in the pilot of the housing.
 - Remove the spacer from the housing.
 - Remove the shaft from the housing.
 - Remove the bearing, thrust bearing, and two (2) thrust washers from the shaft.
2. Being careful not to drop bearing rollers,
 - Pry out the shaft seal, backup seal, and dust seal from the bearing assembly.

NOTE: It is not necessary to remove the metal backup ring from the bearing to service the motor.

- Remove the high pressure seal from the groove in the pilot of the housing.
 - Discard shaft seal, backup seal and high pressure seal.
3. Clean all parts in an oil-based solvent and dry using compressed air.

Housing and Shaft Assembly

1. Apply a light coating of fluid to all new seals prior to installation.
 - Install the high pressure seal into the groove in the pilot of the housing.
2. Place the shaft on a clean, flat surface with the output end facing up.
 - Place the first thrust washer, thrust bearing and second thrust washer over the shaft.
 - Using plastic installation sleeve, place the shaft seal over the shaft with the lip facing down.
 - Repeat for the backup seal, making sure the lip faces down.
 - If the metal backup ring came out in *Step 2* above, place it over the shaft with the large O.D. facing down.
 - Lightly grease the bearing and place it over the shaft with the large O.D. facing down.
 - Use an arbor press to carefully press the bearing down to press the seal assembly into the bearing.
3. Place the shaft assembly into the housing.
 - Place the dust seal over the shaft with the lip facing up.
 - Place the bearing spacer and retaining snap ring over the shaft.

NOTE: It may be necessary to lightly tap the snap ring and bearing spacer to allow the retaining ring to seat properly.

- Replace all shaft related components (i.e. keys, wire rings, nuts).

Motor Section Disassembly

1. Make a "V" shaped set of alignment marks on the end-cover and housing to aid in the reassembly process.
 - Clamp the motor housing in a vise with the shaft facing down.
2. Remove the seven (7) bolts that hold the motor assembly together.
 - Carefully remove the end-cover - *be aware that the piston and spring may fall out.*
 - Carefully remove the piston from the end-cover and set it aside.
 - Remove and discard the O-ring seal and backup seal.
 - Remove the spring and set it aside.
3. Lift commutator container and commutator from the motor and set aside.
 - Place commutator on a flat, clean surface with the seal facing up.
 - Gently tap on the seal with a small screwdriver until the opposite side of the seal lifts from the groove. Remove the seal and discard.
4. Remove the manifold, rotor set, and divider plate. Remove all seals and discard.

CAUTION: Do not allow rollers to drop from the rotor assembly when removing the rotor from the motor.

- Remove the drive link from the motor and set aside.
5. Clean all parts in an oil-based solvent and dry using compressed air. Apply a light coating of fluid to all new seals prior to installation.

Motor Section Assembly

1. Install the drive link into the end of the shaft with the tapered end facing up.
 - Place the rear housing seal in the groove in the housing.
 - Place the divider plate onto the housing.
 - Place body seals in grooves in both sides of the rotor.
 - Place the rotor onto the housing with the side of the rotor with chamfer in splines facing the housing.
 - Place the manifold over the rotor with the seal-groove side up.
 - Install the manifold seal
2. Install the commutator seal into the commutator with the metal side facing up.
 - Use finger pressure to press the seal down flush with the surface of the commutator.
 - Place the commutator onto the manifold and then place the commutator onto the protruding end of the drive link. Make sure that the seal side is facing up.
3. Install the remaining body seal in the groove on the end-cover.
 - Install the piston spring into the end-cover, then the white backup seal followed by the O-Ring seal.
 - Line up the alignment pin with the hole in the end-cover and press the piston into the end-cover.
 - While holding the piston in place, lower the end-cover assembly onto the motor. Align the "V" shaped marks that were made on the housing and end-cover before disassembly.
4. Install the seven (7) assembly bolts.
 - Tighten bolts in sequence (see illustration)
 - Pre-torque to 10 ft. lbs. (13.6 Nm).
 - Final torque to 50 ft. lbs. (67.8 Nm).

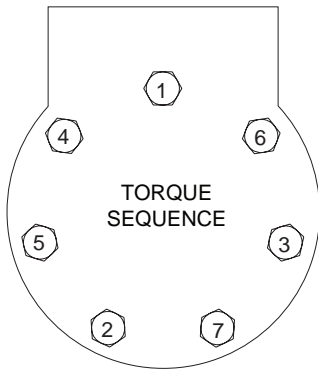

PRE-TORQUE = 10 FT LBS
FINAL TORQUE = 50 FT LBS

"V" Marks for Reassembly

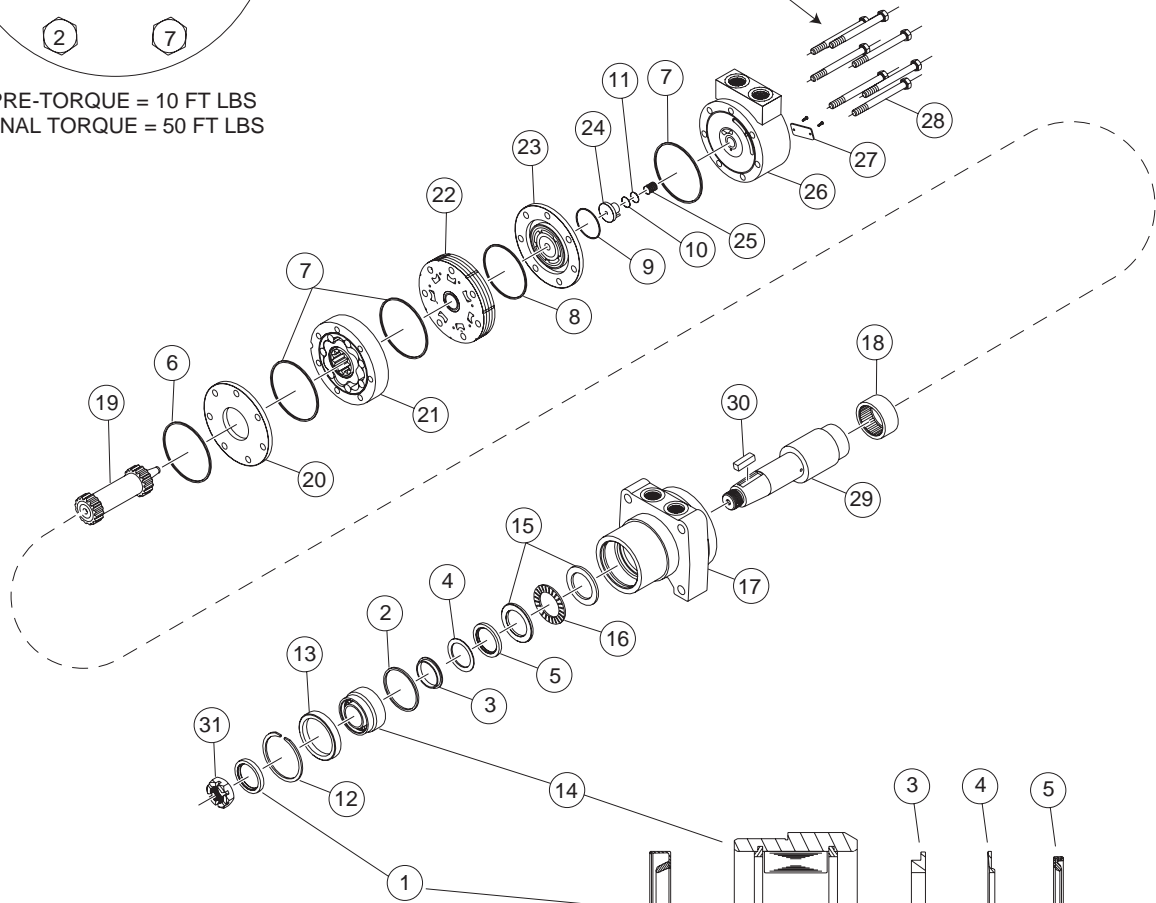
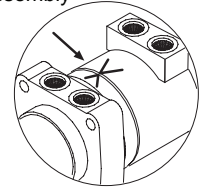

DT701 Series Motor Components

- | | |
|-------------------------|--------------------------|
| 1. * Dust Seal | 17. Housing |
| 2. * High Pressure Seal | 18. Rear Housing Bearing |
| 3. * Metal Backup Shim | 19. Drive Link |
| 4. * Backup Seal | 20. Divider Plate |
| 5. * Shaft Seal | 21. Rotor Assembly |
| 6. * Housing Seal | 22. Manifold |
| 7. * Body Seals (3) | 23. Commutator Assembly |
| 8. * Manifold Seal | 24. Endcover Piston |
| 9. * Commutator Seal | 25. Piston Spring |
| 10. * O-Ring Seal | 26. Endcover |
| 11. * Backup Seal | 27. I.D. Tag Assembly |
| 12. Retaining Snap Ring | 28. Assembly Bolts (7) |
| 13. Bearing Spacer | 29. Shaft |
| 14. 1.5" Bearing | 30. Shaft Key |
| 15. Thrust Washers (2) | 31. Shaft Nut |
| 16. Thrust Bearing | |

* Contained in seal kit

DUST SEAL

1.5" BEARING

METAL BACKUP RING

SHAFT SEAL

BACKUP SEAL



ILLUSTRATION No.
ART_2548



Rear Wheel Motors with Brakes (DT-710)

Disassembly

1. Make a "V" shaped set of alignment marks on the end-cover and housing to aid in the reassembly process.
 - Clamp the motor housing in a vise with the shaft facing down.
2. Remove the seven (7) bolts that hold the motor assembly together.
 - Carefully remove the end-cover - *be aware that the piston and spring may fall out.*
 - Carefully remove the piston from the end-cover and set it aside.
 - Remove and discard the O-ring seal and backup seal.
 - Remove the spring and set it aside.
3. Lift commutator container and commutator from the motor and set aside.
 - Place commutator on a flat, clean surface with the seal facing up.
 - Gently tap on the seal with a small screwdriver until the opposite side of the seal lifts from the groove. Remove the seal and discard.
4. Remove the manifold, rotor set, and divider plate. Remove all seals and discard.

CAUTION: Do not allow rollers to drop from the rotor assembly when removing the rotor from the motor.

- Remove the drive link from the motor and set aside.
5. Clean all parts in an oil-based solvent and dry using compressed air.

Assembly

1. Apply a light coating of fluid to all new seals prior to installation.
2. Place the housing on a clean, flat surface with the output end facing up.
 - Install the dust seal with the lip on the seal facing up.
 - Clamp the housing in a vise with the pilot on the housing facing down.
 - Install the metal backup shim into the bore.
 - Install the backup seal into the housing bore with the lip on the seal facing up.
 - Install the shaft seal into the housing bore with the lip on the seal facing up.
 - Refer to illustration for seal orientation.
3. Install the bearing shims (not shown in illustration) in housing.
 - Install housing bearing.
 - Install the shaft being careful not to cut seal lip with the shaft keyway.
4. Locate the thick disk stamping and set it aside.
 - Install one (1) disk stamping into the housing. Make sure that lugs or splines engage those in the housing.
 - Install one (1) friction disk engaging splines on the disk with those on the shaft.
 - Alternate disk stampings and friction disks until all disks except the thick disk stamping are installed.
 - Install the thick disk stamping on top of the disk assembly.

5. Install the small O-Ring seal and large O-Ring seal into corresponding grooves in the piston.
 - Install small seal and large seal in corresponding grooves over the O-Ring seals.
 - Thoroughly coat the seals and sealing surfaces of the housing with clean fluid.
 - Install the piston into the housing with the large O.D. side facing up.
 - Evenly press the piston down. Be careful not to pinch the seals.

IMPORTANT: If the disks and disk stampings are going to be replaced, the stack up on the new disks must be between .620 and .630 (15.7 mm and 16 mm) (see illustration).

6. Install spring on top of the piston.
 - Install O-Ring seal in groove in the rear surface of the housing.
 - Install the rear shaft bearing. Make sure that the snap ring that retains the bearing rolls faces out.
 - Place the rear housing onto the front housing and line up bolt holes.
 - Hold the motor assembly together, remove from the vise and place in an arbor press.
 - Press down on the rear housing until it contacts the front housing and lock the press
 - Install eight (8) cap-screws and torque to 45 ft. lbs. (61 Nm).
7. Install the drive link into the end of the shaft with the tapered end facing up.
 - Place the body seals in the grooves in both sides of the rotor.
 - Place the rotor onto the housing with the side of the rotor with the chamfer in the splines facing the housing.
 - Place the manifold over the rotor with the seal groove side up.
 - install the manifold seal.
8. Install the commutator seal into the commutator with the metal side facing out.
 - Use finger pressure to press the seal down flush with the surface of the commutator.
 - Place the commutator onto the manifold and then place the commutator onto the protruding end of the drive link. Make sure that the seal side is facing up.
9. Install the remaining body seal in the groove on the end-cover.
 - Install the piston spring into the end-cover, then the white backup seal followed by the O-Ring seal.
 - Line up the alignment pin with the hole in the end-cover and press the piston into the end-cover.
 - While holding the piston in place, lower the end-cover assembly onto the motor. Align the "V" shaped marks that were made on the housing and end-cover before disassembly.
10. Install the seven (7) assembly bolts.
 - Tighten bolts in sequence (see illustration)
 - Pre-torque to 10 ft. lbs (13.6 Nm).
 - Final torque to 50 ft. lbs (67.8 Nm).

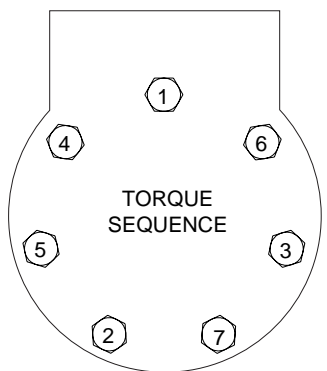

PRE-TORQUE = 10 FT LBS
FINAL TORQUE = 50 FT LBS

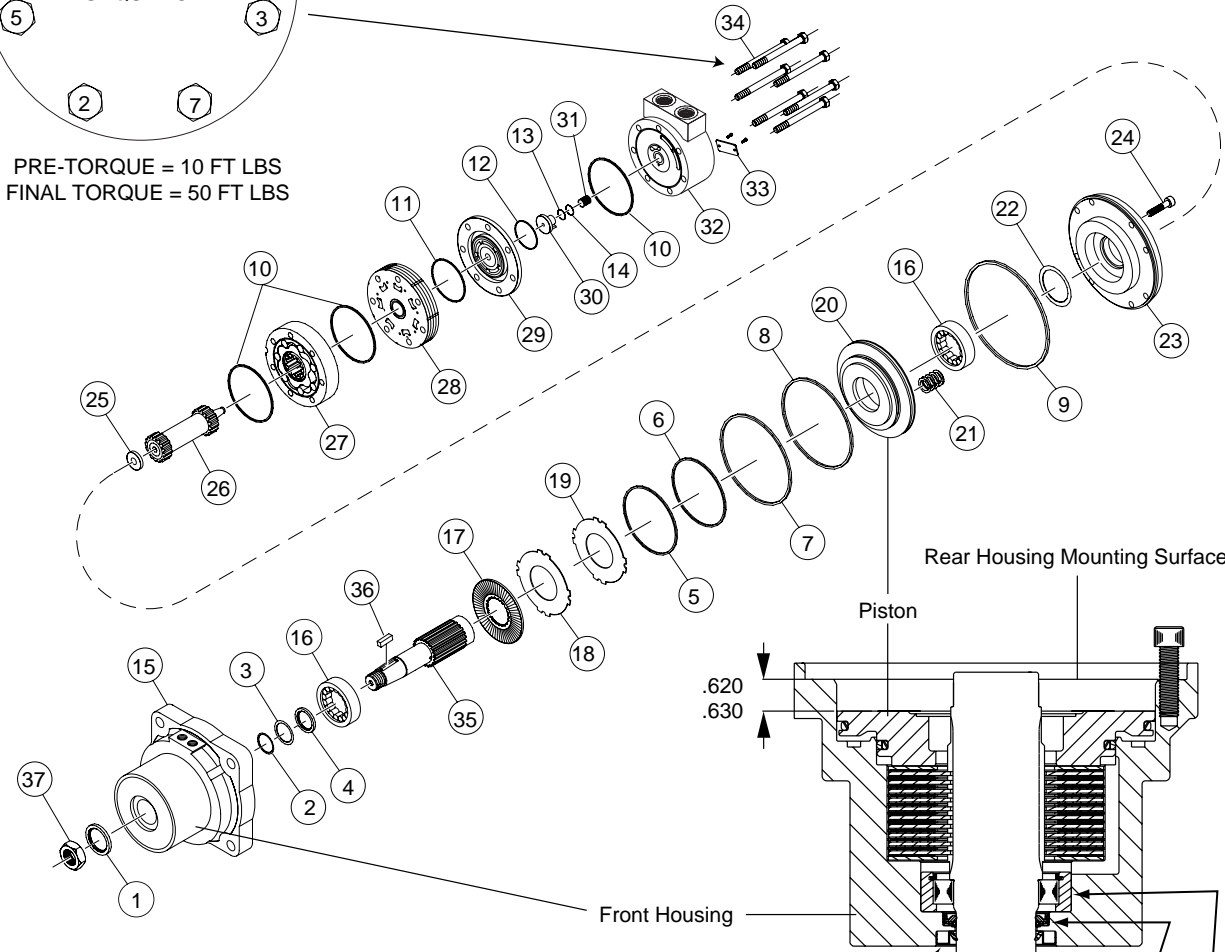
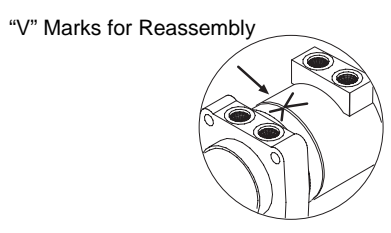

DT710 BRAKE MOTOR COMPONENTS	
1. Dust Seal	20. Piston
2. Metal Backup Shim	21. Springs (25)
3. Backup Seal	22. Spacer Shims (1-3)
4. Shaft Seal	23. Rear Housing
5. Small Piston O-Ring Seal	24. Capscrews (8)
6. Small Piston Seal	25. Drive Link Spacer
7. Large Piston O-Ring Seal	26. Drive Link
8. Large Piston Seal	27. Rotor Assembly
9. O-Ring Seal	28. Manifold
10. Body Seals (3)	29. Commutator Assembly
11. Manifold Seal	30. Endcover Piston
12. Commutator Seal	31. Piston Spring
13. O-Ring Seal	32. Endcover
14. Backup Seal	33. I.D. Tag Assembly
15. Housing	34. Assembly Bolts (7)
16. Shaft Bearing	35. Shaft
17. Friction Disks (10)	36. Shaft Key
18. Disk Stampings (9)	37. Shaft Nut
19. Thick Disk Stampings (2)	

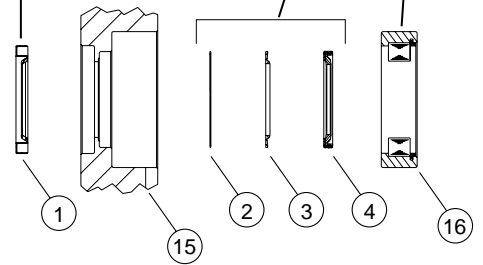

ILLUSTRATION No.
ART_2549



PARKING BRAKE AND TOWING CIRCUIT

Note: Refer to *Parts Section E* for hose routing.

Machine can be winched or moved short distances in case of power failure at speeds not to exceed 5 M.P.H. (8.05 k.p.h.).



Prior to manually releasing brakes, insure wheels are chocked to prevent machine from moving.



AFTER RELEASING THE BRAKES, THERE IS NOTHING TO STOP THE MACHINE'S TRAVEL. MACHINE WILL ROLL FREELY ON SLOPES. BE ON GUARD AGAINST RUNAWAY.

Release Brakes Before Towing:

- Push in the manual Brake Release valve located on the main manifold.
- Using the hand pump on the manifold, pump valve until pressure is built.
- Machine is now ready for towing.

To Reset Brakes:

- Brakes will reset when drive function is activated, or;
- Brakes will reset manually by pulling out the manual brake release valve.

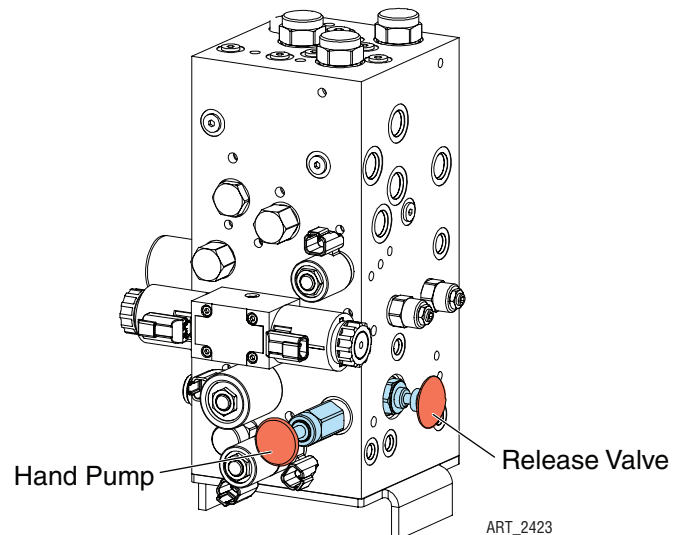

EMERGENCY SYSTEMS AND PROCEDURES



IF THE CONTROL SYSTEM FAILS WHILE THE PLATFORM IS ELEVATED, HAVE AN EXPERIENCED OPERATOR USE THE EMERGENCY LOWERING PROCEDURE TO SAFELY LOWER THE PLATFORM.

DO NOT ATTEMPT TO CLIMB DOWN BEAMS (SCISSORS) ASSEMBLY.

Before lowering platform, retract the deck extension.

Emergency Lowering

Note: Refer to *Lift Cylinder*.

Emergency lowering system is used to lower the platform in case of power or hydraulic failure. Platform descent is controlled by a flow control orifice located under the pressure hose fitting on the lift cylinder manifold(s). Opening the down valve on the lift cylinder(s) allows hydraulic fluid to return to the reservoir through the pressure hose(s).

3072ES

The Emergency Lowering "T" handle is connected by cable to the down valve on the lift cylinder.

To lower the platform, pull the red "T" handle located at the rear of the machine. Lowering stops when you release the "T" handle.

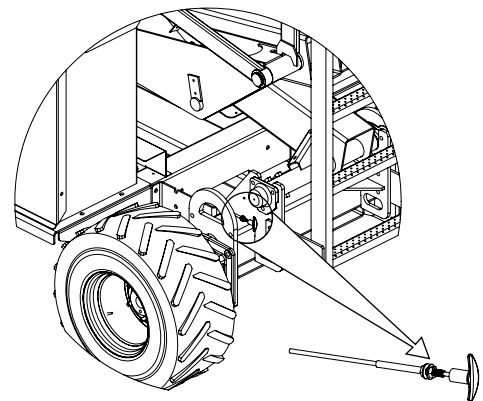
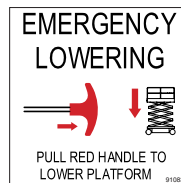

ART_2368

3772ES

The Emergency Lowering switch electrically opens the down valves on the lift cylinder manifolds. It has a dedicated battery to ensure operation in the event of a power failure.

To lower the platform, push down and hold the toggle switch. Lowering stops when you release the toggle switch.

Emergency Lowering Switch

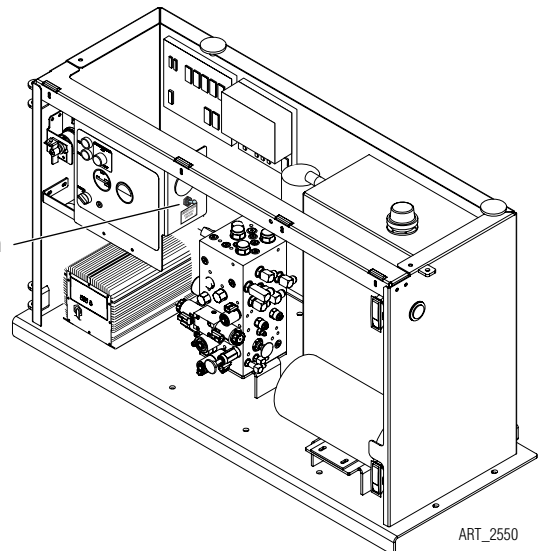
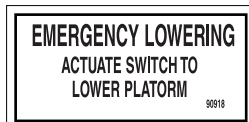

ART_2550

STEERING CIRCUIT

Note: Refer to *Hydraulic Manifold and Relief Pressure Adjustment Procedure*.
 Refer to *Cylinder Repair*.
 Refer to *Section 3* for Remove and Replace instructions.
 Refer to *Parts Section E* for hose routing.

- The wheel motor housings have pivots on the top and bottom, and are mechanically linked together via a tie-rod.
- Steering is accomplished hydraulically using two (2) double-acting cylinders, and a 4-way 3-position solenoid-operated hydraulic directional control cartridge valve.
- Maximum steering pressure is limited by the relief valve.

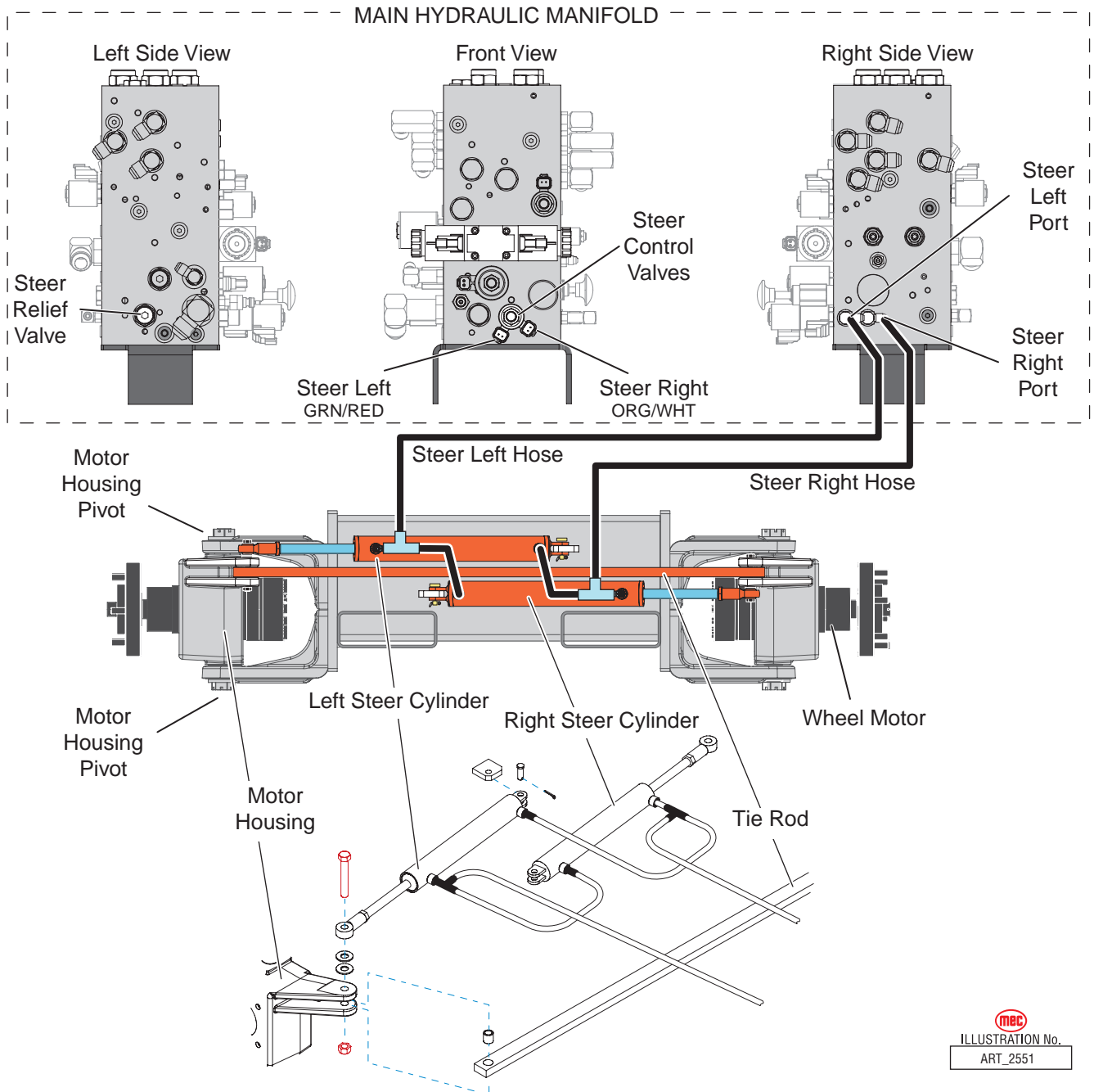

mec
 ILLUSTRATION No.
 ART_2551

PLATFORM LIFT CIRCUIT

Note: Refer to *Hydraulic Manifold and Relief Pressure Adjustment Procedure*.
Refer to *Section 3* for Remove and Replace instructions.

- The lift system uses the hydraulic pump to obtain proportional lifting function controlled by the lift valve and proportional valve.
- Lowering is single speed controlled by the holding valves on the lift cylinder(s) and regulated by a fixed orifice located on the lift cylinder(s).
- Platform capacity is limited by a hydraulic relief valve in the lift circuit. (Refer to Machine Specifications or the Hydraulic Schematic for proper setting).

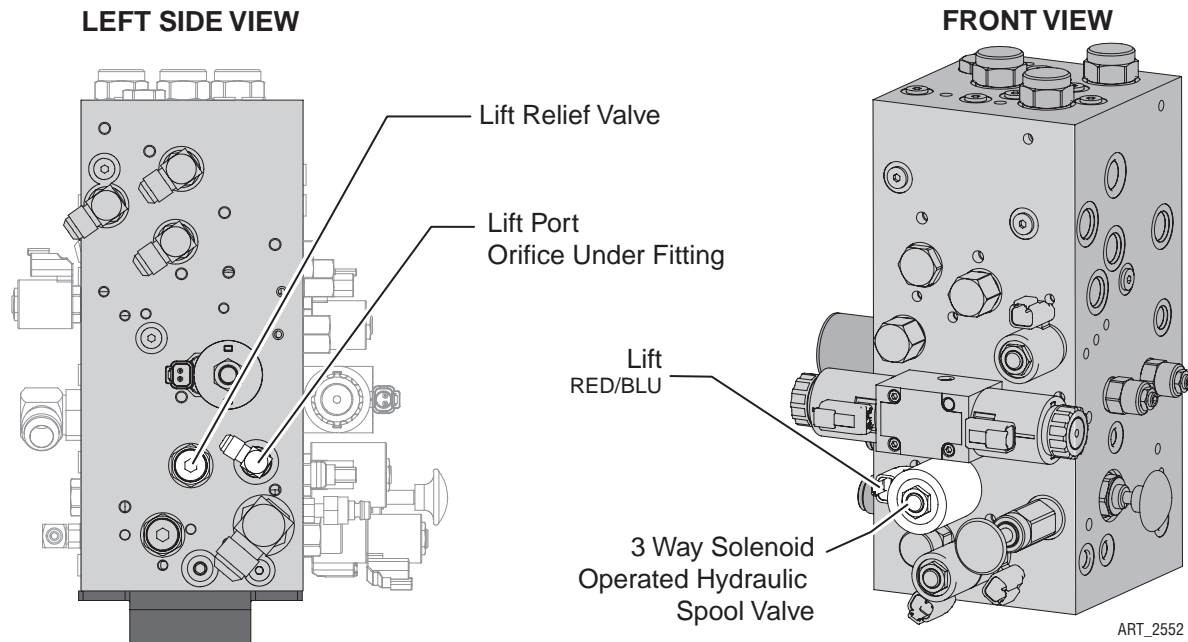

Lift Cylinder

Note: Refer to *Emergency Lowering*.
Refer to *Cylinder Repair*.

Lift cylinders have an integrated down (holding) valve. The normally closed valve is 2-position, 2-way solenoid operated and holds the platform in position by preventing hydraulic fluid from returning to the reservoir while the valve is closed. The normally closed holding valve prevents retraction of the cylinder rod (and platform descent) should a hydraulic line rupture or a leak develop between the cylinder and its related control valve. The valve is also externally actuated for lowering the platform in emergency situations.

3072ES

The 3072ES is equipped with one (1) single acting type hydraulic cylinder.

The down valve is also externally actuated via a cable for manually lowering the platform.

3772ES

Two (2) single acting type hydraulic cylinders.

The down valves are also externally actuated via a toggle switch for manually lowering the platform.

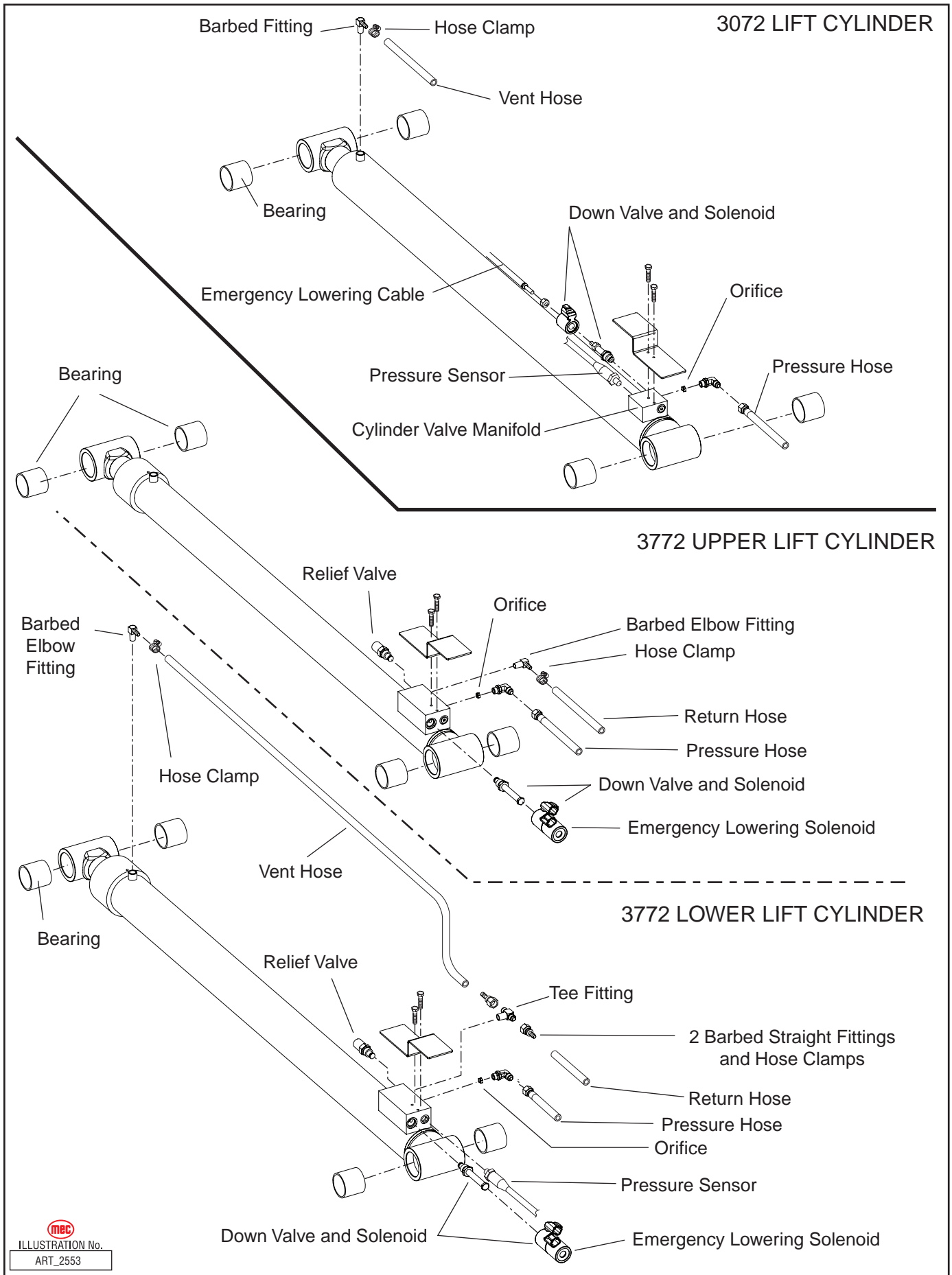



 ILLUSTRATION No.
 ART_2553

OPTIONAL OUTRIGGERS

Note: Refer to *Section 3* for detailed description and troubleshooting.
Refer to *Cylinder Repair*.

Outrigger Hydraulic Manifold

The Optional outrigger manifold is located in the Control Module behind the Lower Control Box.

Cylinders

Four (4) double acting type hydraulic cylinders.

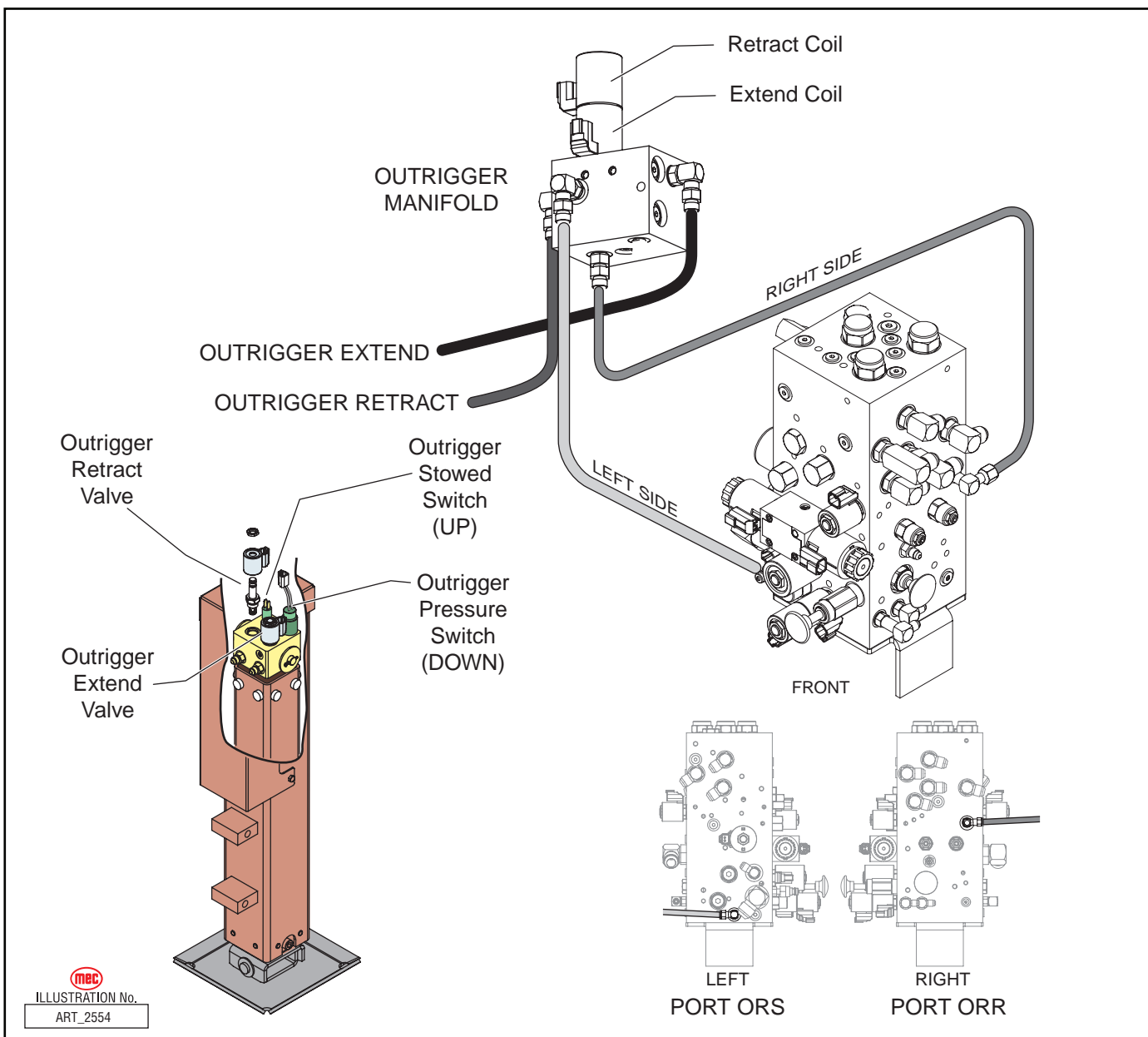

CYLINDER REPAIR



CYLINDERS ARE HEAVY. SUPPORT CYLINDERS BEFORE REMOVING HARDWARE THAT SECURES THE CYLINDER TO THE MACHINE.

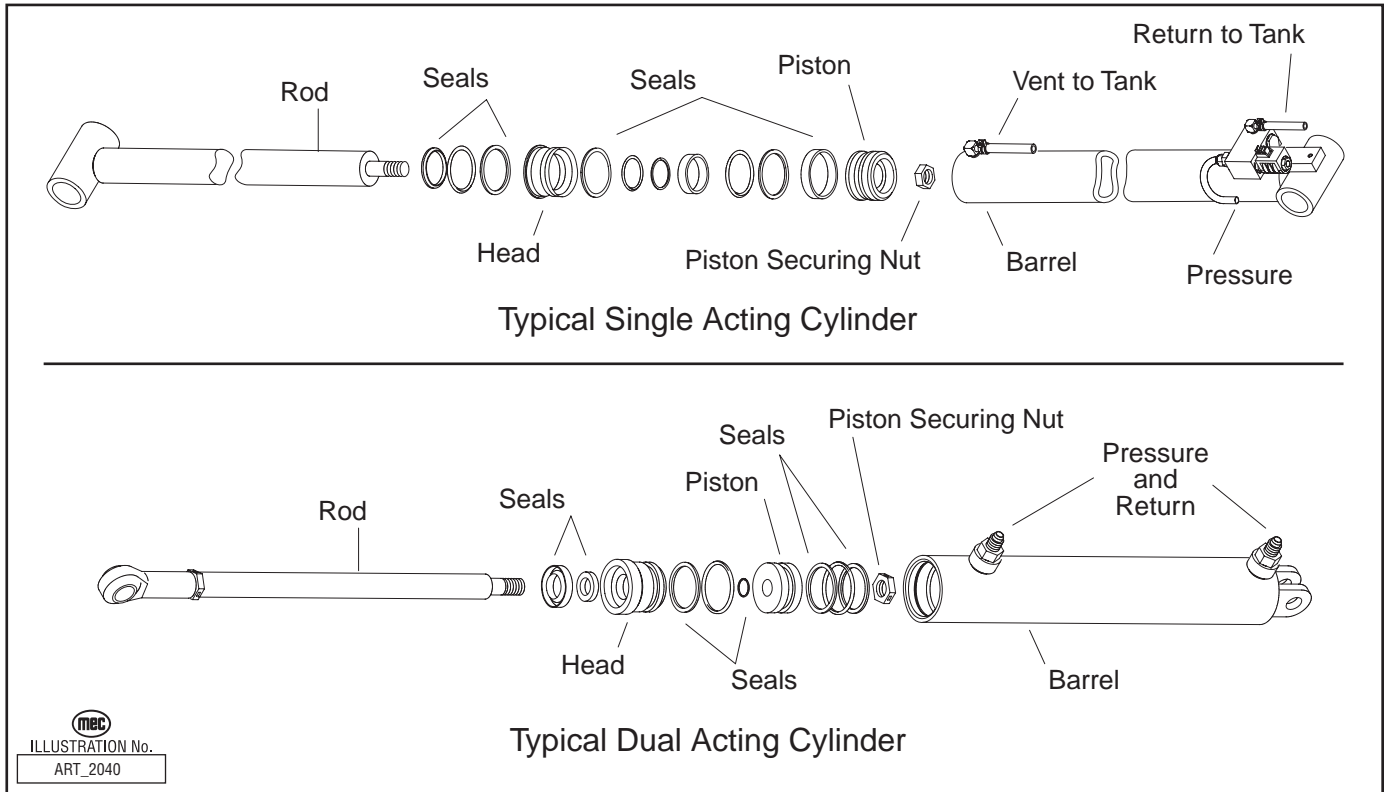

Removal

Note: Refer to *Section 3* for Remove and Replace instructions, and the *Parts Section* for a list of hardware specific to the cylinder being repaired.

1. Tag hoses for proper reassembly.
2. Disconnect hoses and IMMEDIATELY cap the openings to prevent contamination.
3. Remove cylinder from the machine as described in *Section 3*.

Preparation



Take care not to damage rod surface and guard against dirt or other foreign objects entering system.

1. Drain all fluid from cylinder.
2. Clean all dirt and grit from outside of cylinder.
3. Insert cylinder into vise.

Cylinder Disassembly

1. Remove the head from the cylinder body.
2. Remove the shaft assembly from the barrel, pulling in a straight line, so as not to scar the internal parts.
3. Insert shaft into a **soft jawed** vise so that the head and piston can be removed. Be sure the shaft and vise are both clean before using.
4. Remove nut at the end of the shaft and pull head and piston off of the rod.
5. Remove all seals from the head and piston using a non-sharp seal tool. These tools are available from various seal suppliers.
9. Clean all fluid and debris off of the head, piston, shaft, collar and barrel using solvent, rags, and an air hose.
10. Inspect parts for scratches, pits or polishing. Check seal groves and sealing surfaces.
 - Scratches or pits deep enough to catch the fingernail are unacceptable; replace the cylinder.
 - Polishing is a sign of uneven loading. Check for roundness. If a polished surface is not round within .007 inch (0.18 mm) replace the cylinder.

Cylinder Assembly

CAUTION

To insure a quality repair, cylinder parts must be thoroughly cleaned, dry, and free of solvents, and assembly must be performed in a clean area free of dust and contamination.

To avoid cutting the seals, do not use sharp edged tools during seal replacement. After installing seals allow at least one hour for the seals to restore to their original shape before assembling the cylinder.

Torque all hardware according to the *Hydraulic Components Torque Table* unless otherwise specified.

1. Lubricate all components with clean hydraulic fluid.
2. Install new seal kit components. Install all seals on the head and piston using the non-sharp seal tool.
3. Place a small amount of fluid on the inside seals of the head and reinstall it on the shaft, by slipping head over the piston end of the shaft being very careful not to damage the inside seals.
4. Place a small amount of fluid on the inside seals of the piston and reinstall it on the shaft by slowly twisting the piston on over the threads of the shaft being very careful not to damage the inside seals.
5. Reinstall the shaft nut; torque 1½" nut to 160 ft.-lbs. (216.8 Nm).
6. Grease the outside seals of the head and piston.
7. Reinstall the shaft into the barrel of the cylinder and push in until groove of the head lines up with the slot in the barrel.
17. Reinstall the cylinder retainer. Installation is reverse of removal.
18. Cycle the cylinder using air to check for proper operation.

NOTE: It is very important to keep all parts clean when working with hydraulic cylinders, even one small piece of dirt or grit can damage the cylinder.

HYDRAULIC MANIFOLD

Note: Refer to *Section 3* for Remove and Replace instructions, and *Parts Section E* for a list of hardware.

Tag all components as they are removed so as not to confuse their location during reassembly.

Hydraulic Manifold Removal

1. Disconnect the negative battery terminal.
2. Tag and disconnect the solenoid valve leads.
3. Tag and disconnect hydraulic hoses, and IMMEDIATELY cap the openings to prevent contamination.
4. Remove the bolts that hold the manifold to the mounting bracket.
5. Remove the manifold block.

Disassembly

1. Remove coils from solenoid valves.
2. Remove valves.
3. Remove fittings, plugs, springs, balls, and orifices.

Cleaning and Inspection

1. Wash the manifold in cleaning solvent to remove built-up contaminants, then blow out all passages with clean compressed air.
2. Inspect the manifold for cracks, thread damage and scoring where O-rings seal against internal and external surfaces.
3. Wash and dry each component and check for thread damage, torn or cracked O-rings, and proper operation.
4. Replace defective parts and O-rings.

Assembly

Note: Lubricate all O-rings before installation to prevent damage to the O-ring. Seat balls in manifold block by lightly tapping on the ball with a brass drift punch.

1. Install fittings, plugs, springs, balls, and orifices. Use one drop of Loctite #424 or equivalent thread locker on each screw-in orifice.
2. Install valves.

Installation

1. Attach manifold assembly to mounting plate with mounting bolts.
2. Connect solenoid leads (as previously tagged).
3. Connect hydraulic hoses (as previously tagged). Be certain to tighten hoses.
4. Connect the battery.
5. Operate each hydraulic function and check for proper operation and leaks.
6. Adjust valve pressures.

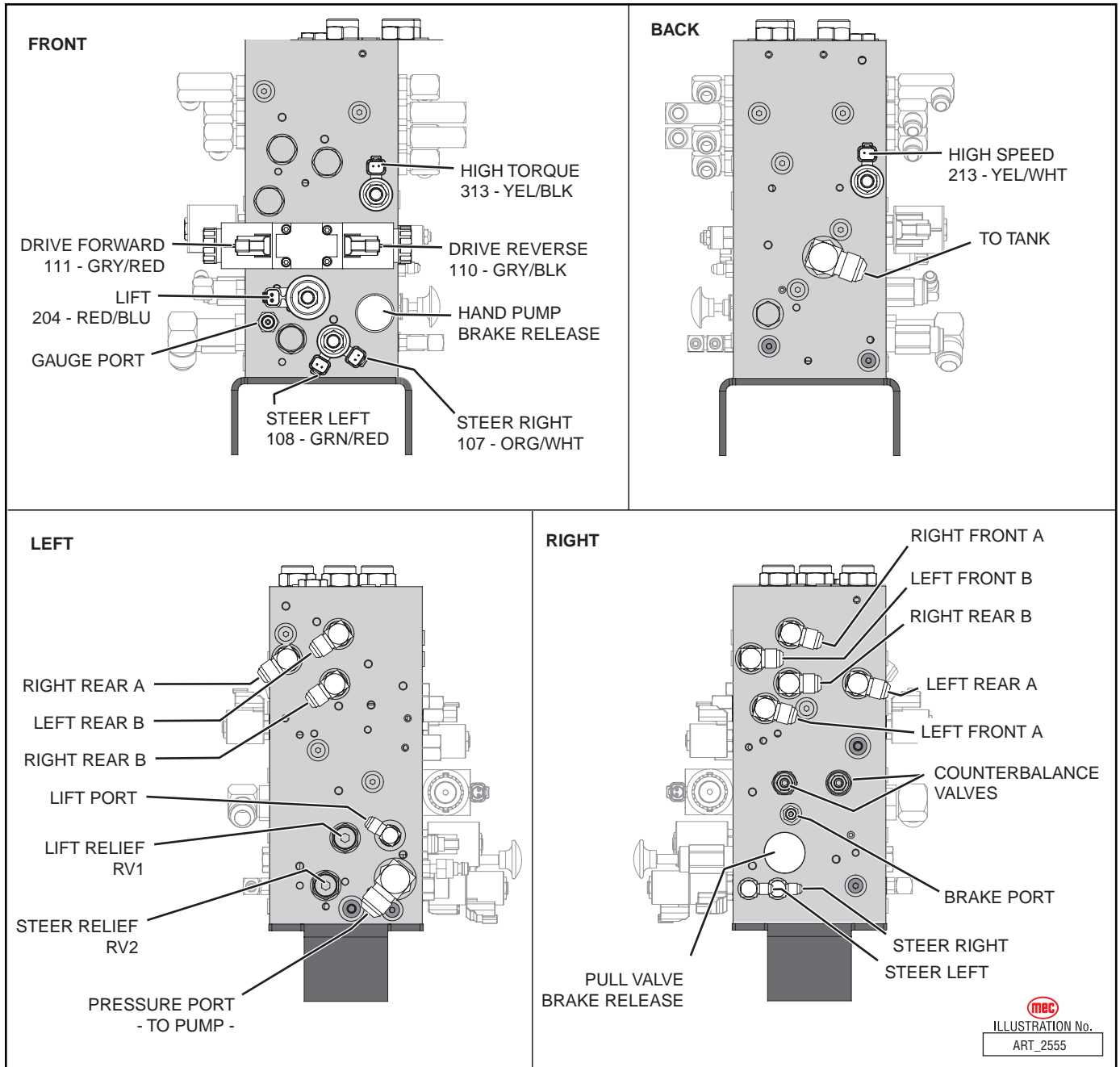

MEC
 ILLUSTRATION No.
 ART_2555





SECTION 2

ELECTRICAL SYSTEM

Electrical System - General	2-2
Diagnostic LED	2-2
Battery Charge Indicator	2-2
Master Disconnect Switch	2-2
Deutsch Connectors	2-3
Batteries	2-4
Battery Replacement	2-6
Battery Charger	2-7
Controls	2-10
Lower Controls	2-10
Upper Controls	2-11
Alarms and Switches	2-12
Limit Switch	2-12
Continuity Checks	2-14
Motor Controller	2-16

ELECTRICAL SYSTEM - GENERAL

The electrical control system consists of lower controls located on the machine base and upper controls located on the machine platform. Emergency lowering controls are also located on the machine base.

Lower Controls

The lower controls will operate all functions except steering and drive.

Upper Controls

The upper controls will operate all functions including drive, steer, lift, and lower. A momentary bidirectional rocker switch on the joystick provides the steering function. The control system for operation of drive, steer, lift, and lower are electric-over-hydraulic type. The drive system is a proportional system controlled by position and direction of the upper controls joystick.

Emergency Lowering (3772ES)

The 3772ES utilizes a toggle switch and independent 12 Volts DC battery to open the down valve on the lift cylinders, allowing hydraulic fluid to return to the hydraulic reservoir at a controlled rate.

Diagnostic LED

If the machine fails to operate, inspect the GP400 Module located inside the control module. The LED located on the processor should be *ON*. If the LED is *OFF* or *FLASHING*, refer to *Section 4: Troubleshooting*.

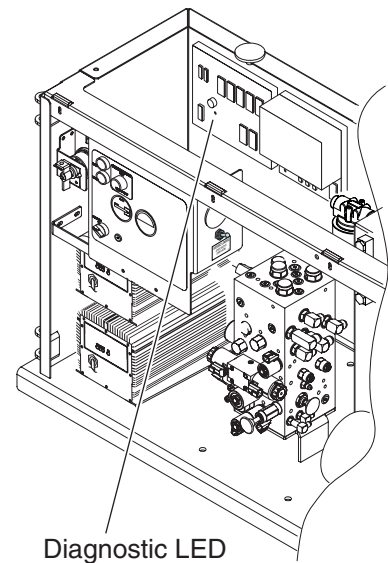

ART_2391

Battery Charge Indicator

If the machine fails to operate properly, check the battery charge indicator located on the lower control panel to ensure that the batteries have a proper state of charge.

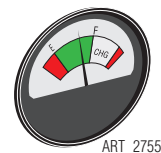

Master Disconnect Switch

Battery disconnect is provided in the control module to facilitate servicing and also to prevent unauthorized use of machine by using a padlock.

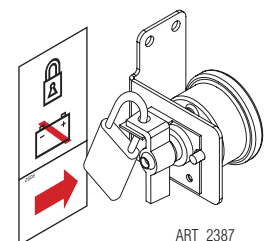

DEUTSCH CONNECTORS

Deutsch connectors used on MEC equipment is designed so that individual parts may be replaced without replacing the entire component. Special tools and detailed instructions are provided in the Deutsch Connector Field Kit, MEC part number 84091.

Male Plug Connector

- Use the flat end of the removal tool or a flat blade screwdriver to pry the locking wedge from the connector, taking care not to damage the sealing gasket.
- Inspect and replace damaged parts.
- Replace or re-crimp wires and contacts.

Female Receptacle Connector

- Use the notched end of the removal tool or a wire hook to pull the locking wedge from the connector.
- Replace worn or damaged parts.
- Replace or re-crimp wires and contacts.

Locking Fingers

- Remove the locking wedge as outlined above.
- Using the removal tool or a flat blade screwdriver, push the locking fingers aside to release the contact.
- Pull the wire and contact out of the connector.

Heavy Duty Plug

- Slide the removal tool along the wire to be replaced and push into the connector to release the contact.
- Pull the wire and contact out of the plug.

Crimping

- Strip 1/4 inch (6 mm) insulation from the wire.
- Insert the contact into the crimping tool and insert the stripped wire into the contact making sure no wires are outside the contact barrel.
- Close the handles of the crimping tool, then release the handles to remove the crimped contact.

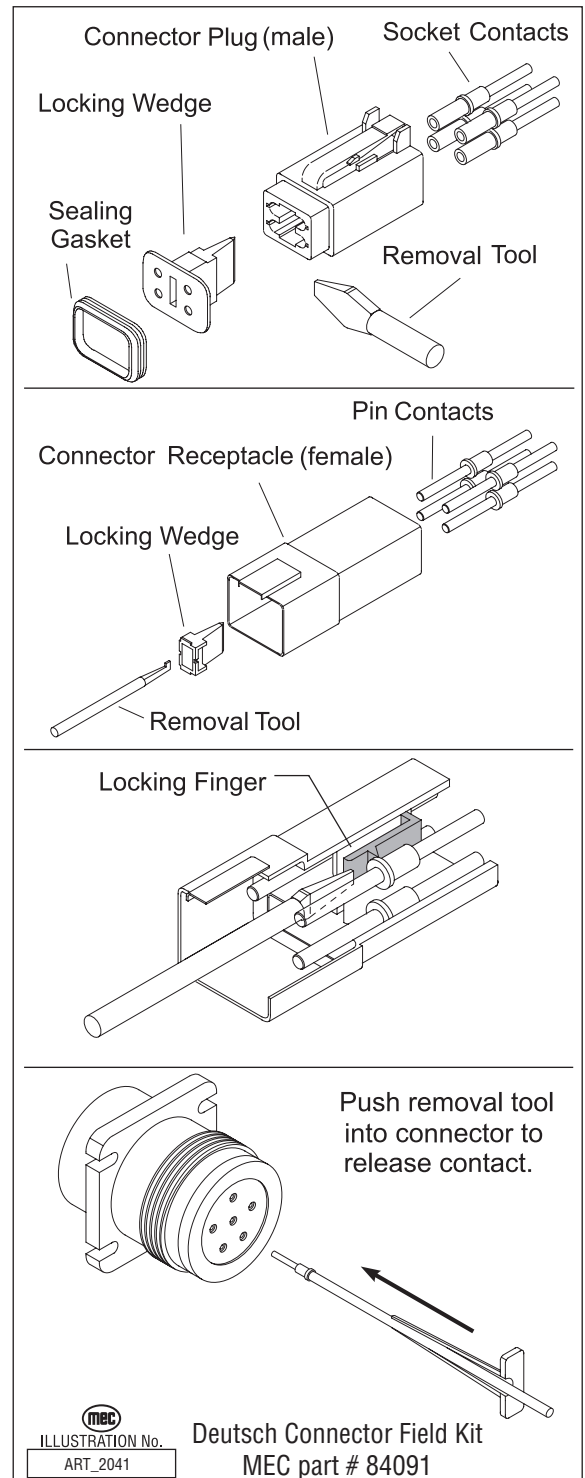

BATTERIES



CHARGING BATTERIES CREATES EXPLOSIVE HYDROGEN GAS. KEEP SPARKS, FLAMES AND SMOKING MATERIALS AWAY FROM BATTERIES.

ALWAYS WEAR SAFETY GLASSES WHEN WORKING WITH BATTERIES.

BATTERY FLUID IS CORROSIVE. THOROUGHLY RINSE SPILLED FLUID WITH CLEAN WATER.

REPLACE WITH MANUFACTURER APPROVED BATTERIES.

BEFORE DISCONNECTING THE BATTERY NEGATIVE (-) LEAD, MAKE SURE THAT ALL SWITCHES ARE OFF. IF ON, A SPARK WILL OCCUR AT THE GROUND TERMINAL THAT COULD IGNITE HYDROGEN GAS VAPORS.

Eight (8), 6 Volts DC batteries supply the 48 Volts DC electrical power required to operate the electrical circuits.

One 12 Volts DC battery supplies power to operate the emergency lowering circuit for the 3772ES.

Battery Maintenance (in storage)

Follow these procedures for maintenance of battery on a machine not in use:

- Keep battery clean. Electrolyte of “wet” lead acid type flooded batteries should be checked regularly and kept at proper level.
- Never stack one battery directly on top of another because post or container damage can result. If batteries are stored individually, place supporting boards between layers. Rotate stock so that oldest batteries are used first.
- “Wet” batteries should be kept fully charged. A “wet” battery, while in storage, should be recharged to full charge at recommended intervals. Leaving the MEC charger connected to an un-switched AC power source during prolonged storage will maintain battery voltage automatically.

A battery fully (100%) charged at 80° F (26.6° C)

- drops to 65% at 32 °F (0° C)

- drops to 40% at 0° F (-32° C)

Recommended Intervals

If Stored At:	Recharge:
Below 40° F (4° C)	None required
Above 60° F (15° C)	Every month
40°-60° F (4°-15° C)	Every 2 months

Battery Maintenance (in use)

Check battery and surrounding area for signs of damage or corrosion.

Check battery terminals for:

- Corrosion: Regularly clean connections and apply a nonmetallic grease or protective spray to retard corrosion.
- Loose connections: Be sure all cable connections are tightly secured, and that good contact is made with terminals.
- Broken, swollen, or frayed cables: Be sure all connections are good and that no loose or broken wires are exposed. Replace as necessary.

Check battery electrolyte level and replenish the electrolyte if necessary. Remove battery vent caps before filling, and USE ONLY DISTILLED WATER. DO NOT OVERFILL. Fill to level indicator (if there is no level indicator, fill to ½ inch over the top of the separators). Fill after charging to prevent overflow of acid due to expansion. Do not use a hose to add water to batteries.

Allowing the electrolyte level to drop below the top of the separators will lead to shortened battery life.

Excessive water usage can indicate that a battery has been overcharged, has been subjected to excessively high temperatures, or is nearing the end of its service life.

Battery Preventative Maintenance:

Every 15 hours (after battery has been charged), spot-check the specific gravity of two or more cells. A fully charged battery should indicate 1.28 specific gravity. If low readings are noted, check the following:

- Check terminals for corrosion, loose connections and broken, swollen, or frayed cables.
- Check all cells with a hydrometer for variance in specific gravity. A variation of 0.03 points or more between cells is a cause for concern. Mark the low cells.

Recheck specific gravity of all cells after recharging. Wash the top of the battery, making sure all vent caps are in place. Do not allow cleaning water or other foreign matter to enter the cells. Use a solution of bicarbonate soda and water (5 tsp. of baking soda per quart of warm water) to wash the battery if there is an accumulation of acid.

Battery Specific Gravity and Voltage Table

SPECIFIC GRAVITY		VOLTS DC		
		PER CELL	6 V BATTERY	12 V BATTERY
Fully Charged	1.280	2.10	6.30	12.60
Fully Discharged	1.130	1.75	5.19	10.50

Battery Replacement



BEFORE REMOVING A BATTERY FROM THE MACHINE, TURN OFF THE MASTER DISCONNECT SWITCH. THERE SHOULD BE NO POWER.



Prevent damage to battery and/or electrical system;

- Always disconnect the negative battery cable first.
- Always connect the positive battery cable first.

To remove a battery;

1. Turn OFF the Master Disconnect switch.
2. Disconnect the battery cables and remove battery hold-down hardware.
3. Lift the battery from the compartment, put the battery aside and dispose of properly.

To install a battery;

1. Position the battery in the compartment as illustrated and secure with hold-down hardware.
2. Connect battery cables as illustrated.

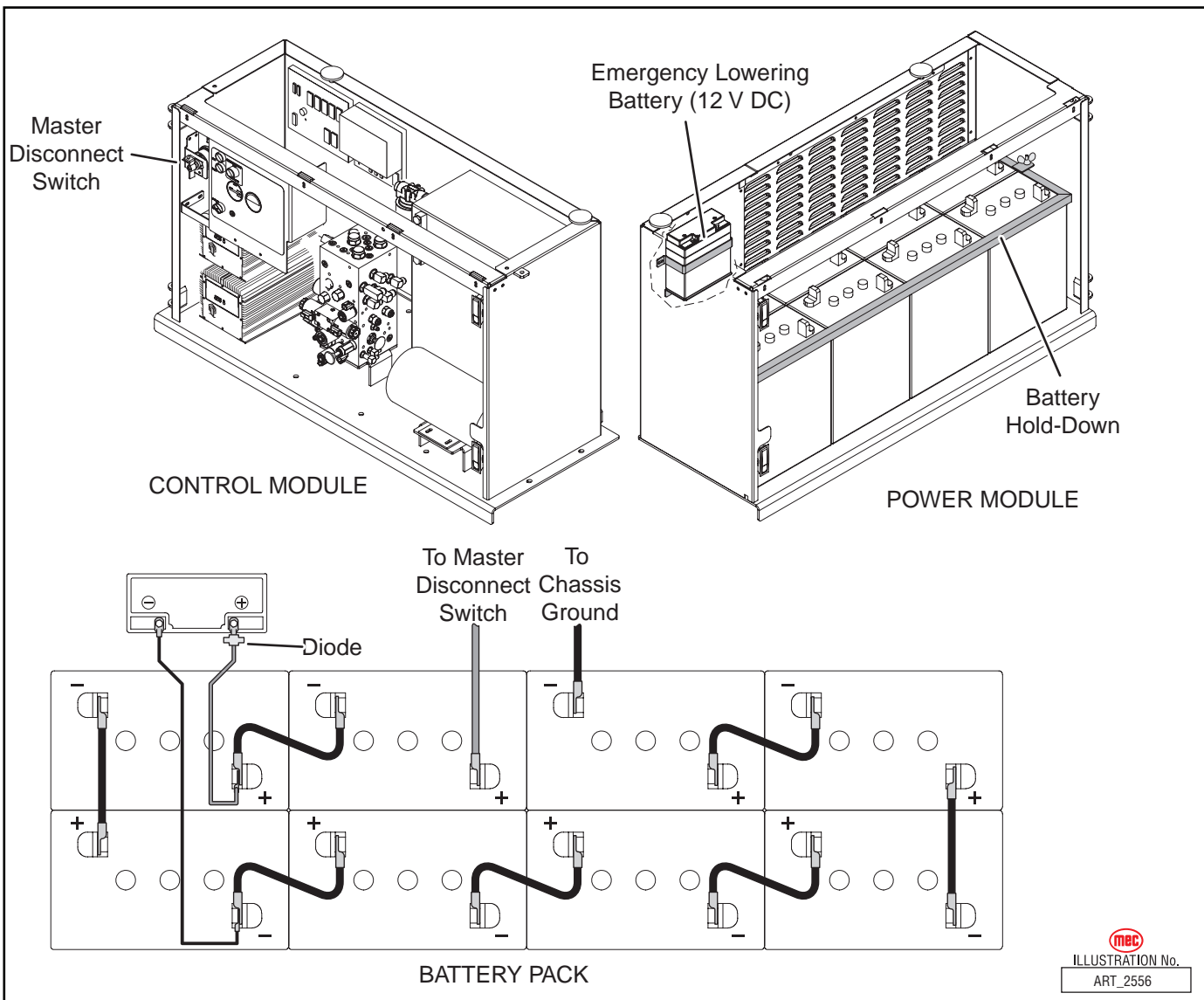

Battery Charger

Electrical Requirements



The use of an improper extension cord could result in a risk of fire or electric shock.

The use of long extension cords should be minimized. If an extension cord is used, ensure that it has three conductors with a ground and that the wire size and length meet electrical code for the voltages and currents of the Electrical Specifications table. Locate all cords so that they will not be driven over, stepped on, tripped over, or otherwise subjected to damage or stress.

Refer to the *Operator's Manual* for detailed charging instructions.

Refer to *Section 4 - Troubleshooting*.

Refer to *BATTERIES* earlier in this section.

Electrical Specifications Table - Battery Charger			
	MODEL	HB750-24 (2 CHARGERS)	HB1500-48
AC Input	Voltage	115 V (85-132 V) 230 V (170-264 V) (automatically selects)	100 V (85-137 V) 240 V (170-264 V) (automatically selects)
	Maximum Current	9.5 A at 85 V 4.8 A at 170 V	16 A at 96 V AC 8 A at 170 V AC
	Frequency	60 / 50 Hz	50 / 60 Hz
	Phase	Single	Single
DC Output	Voltage	29.6 V DC	61 V DC
	Maximum Current	25.0 A DC	25.0 A DC
	Output Power	750 Watts	1500 Watts

Battery Charger Maintenance



SHOCK HAZARD - MAY CAUSE SERIOUS INJURY OR DEATH.

DISCONNECT FROM AC VOLTAGE BEFORE DOING ANY SERVICE.

DO NOT TOUCH UN-INSULATED PARTS OF CHARGER WIRES, BATTERY CONNECTOR OR BATTERY TERMINALS.

BE CAREFUL WITH TOOLS AROUND ELECTRICAL PARTS TO AVOID ARCING OR SHORTING.

REMOVE RINGS, WATCHES, AND JEWELRY TO AVOID ARCING AND SHOCK.

Proper charger and battery maintenance will ensure safe and efficient charging and longer battery life. Most battery charging problems relate to battery care and not charger problems.

1. Keep electrical connections clean and tight. Loose or corroded wires and fittings will cause an output error.
2. Keep the charger fins clean to improve cooling. If fins are covered with debris the charger's over-temperature protection system may reduce charging power.
3. Replace the charger if case damage breaks the watertight seal.
4. Inspect wiring weekly for pinching, cut or damaged insulation, or other damage.
 - AC Ground – green with yellow stripe
 - AC Neutral – light blue
 - AC Line (Hot) – brown
 - DC Battery Negative (–) – black
 - DC Battery Positive (+) – red
 - Interlock Wires – black and white (prevents machine operation while charging)

IMPORTANT: All MEC electric scissor lifts are equipped with lead acid type flooded batteries. The yellow wire loop on the back of the charger must be intact. If it is cut, broken, or damaged, the charger may go into GEL charging mode, causing damage to the machine and/or batteries.

Single Chargers

Current models are equipped with a single 1500 Watt 48 Volts DC battery charger.

BATTERY CHARGER INDICATOR

	YELLOW	80%	100%	FAULT
No AC power to charger	OFF	OFF	OFF	OFF
Normal operation, charger is charging	ON	OFF	OFF	OFF
Normal, battery is over 80% charged	ON	ON	OFF	OFF
Normal, battery is 100% charged	OFF	OFF	ON	OFF

Please see service manual for additional information.

STATUS

80% 100%

FAULT

HB1500-48

ILLUSTRATION No. ART_2374

Dual Chargers

Early models are equipped with two 750 watt 24 Volts DC battery chargers working in-line to provide 48 Volts DC to the battery pack.

BATTERY CHARGER INDICATOR

	50%	75%	100%
0 to 50% charged	Blinking	OFF	OFF
50% to 75% charged	ON	Blinking	OFF
75% to 100% charged	ON	ON	Blinking
100% charged	ON	ON	ON

Please see service manual for additional information.

LEDs

50% 75% 100% GEL

HB750-24

ILLUSTRATION No. ART_2373

CONTROLS

EMERGENCY STOP Switch

There are two red Emergency Stop switches: One located on the upper controls and one on the lower controls. Activation of either Emergency Stop switch will immediately cut electrical power to all controls, thereby stopping all machine functions. Press the switch to stop all electrical power and turn the switch clockwise to reset.

When both Emergency Stop switches are “set”, the controls have electrical power and the machine will operate.

NOTE: Both switches must be set or the machine will not operate.
The electric Emergency Lowering switch (3772ES) will continue to function when the Emergency Stop switches are depressed.

Lower Controls

PLATFORM/BASE Selector Switch

Use this switch to set machine operation to the upper controls (PLATFORM) or the lower controls (BASE).

When the switch is set to PLATFORM, all lower controls functions are disabled with the exception of the Emergency Stop switch.

When the switch is set to BASE, all upper controls functions are disabled with the exception of the Emergency Stop switch.

When the switch is set to OFF, all functions are disabled.

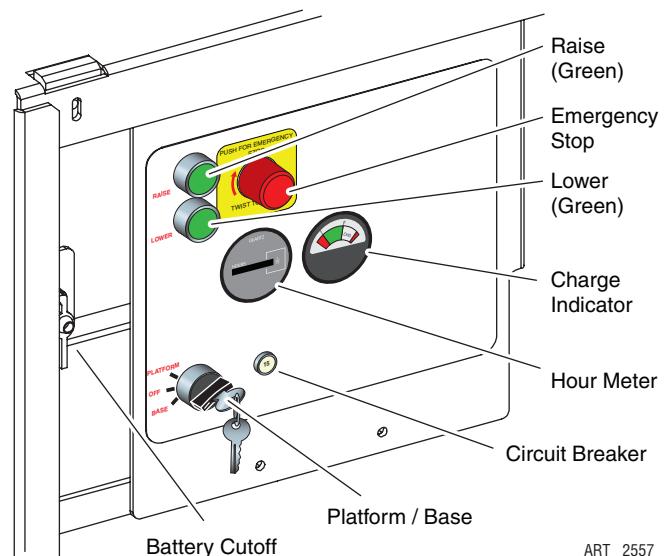

ART_2557

RAISE Button

Type of switch: momentary push button. Press and hold the RAISE button to cause the platform to elevate at a steady, single speed.

LOWER Button

Type of switch: momentary push button. Press and hold the LOWER button to cause the platform to descend at a steady, single speed.

Circuit Breaker

The circuit breaker will trip in the event of power overload to prevent electrical damage to the machine. Press to reset. If the circuit breaker continues to trip, take the machine out of service until the electrical problem is diagnosed and corrected (see *Section 4: Troubleshooting*).

Hour Meter

The hour meter records the time that the machine is in operation. Check the hour meter daily to determine if the machine is due for service.

Charge Indicator

The charge indicator indicates the state of charge of the battery pack.

Upper Controls

To operate the machine using the upper controls, the selector switch on the lower control must be set to PLATFORM.

Key Switch

Turn the key switch ON to operate the machine. Turn the key switch OFF and remove the key to shut down and prevent unauthorized use.

MODE SELECT Switch

Type of switch: 1-pole 2-position toggle switch. Used to set operation of the joystick to LIFT or DRIVE.

SPEED / TORQUE Switch

Type of switch: 1-pole 3-position toggle switch. Used to set drive speed. When the machine is elevated above 10 feet (3 m), the switch defaults to MID RANGE no matter what position the switch is in.

HORN Button (option)

Type of switch: momentary push button. Press to sound the horn.

Joystick

Type of switch: proportional control.

LIFT: With the Mode Select switch set to LIFT, squeeze the Enable bar and pull back on the Joystick. Lift speed is controlled by the amount that the Joystick is pulled.

Push forward on the Joystick to lower the platform. It is not necessary to squeeze the Enable bar and the rate of descent is not variable.

DRIVE: With the Mode Select switch set to DRIVE, squeeze the Enable bar and move the Joystick forward to drive forward, or move the Joystick backward to drive in reverse. Drive speed is controlled by the amount that the Joystick is moved.

Enable Bar

Type of switch: momentary button. Squeeze the bar to activate the joystick LIFT, DRIVE, and STEER functions. It is not necessary to squeeze the Enable bar to lower the platform.

Steering Rocker Switch

Type of switch: momentary rocker. Squeeze the Enable Bar and press the Steering switch with your thumb to activate the steering cylinder and turn the front wheels.

AUTOMATIC OUTRIGGERS Switch (option)

Type of switch: 2-pole 2-position momentary toggle switch. Push down and hold the switch to lower the outriggers. Lift up and hold the switch to raise the outriggers.

DRIVE ENABLED Indicator (option)

The indicator light is ON when all four outriggers are fully raised and it is safe to drive the machine. The machine will not drive if the indicator light is OFF.

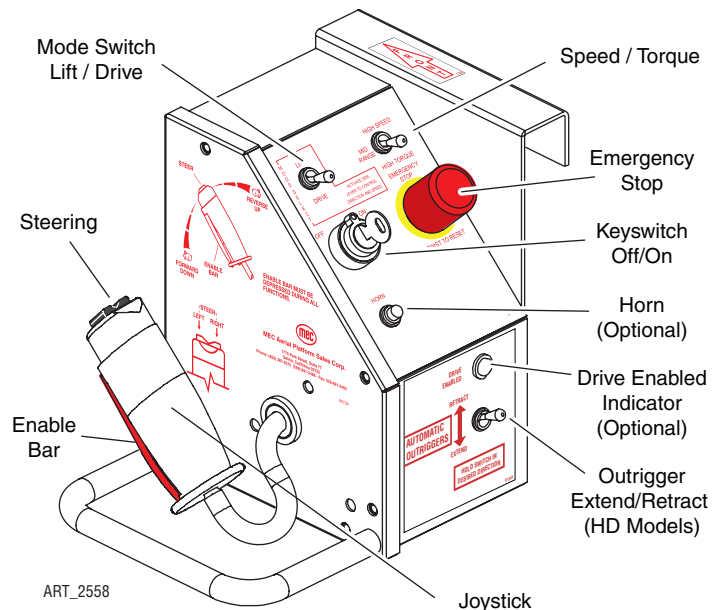

Alarms and Switches

Master Disconnect Switch

All electrical power is routed through the Master Disconnect switch. The switch can be locked in the OFF position with a padlock to prevent unauthorized use.

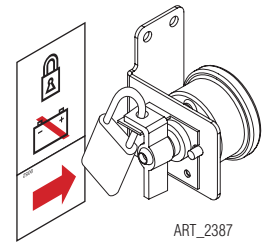

Emergency Lowering Switch (3772ES)

The Emergency Lowering switch is used to lower the platform in case of power or valve failure. The switch receives power from a 12 Volts DC battery that is dedicated to the Emergency Lowering system and located in the power module. To lower the platform, perform the following steps:

1. Push and hold the toggle switch down to lower the platform.
2. Once the platform is fully lowered, release the toggle switch.

Emergency Lowering Switch

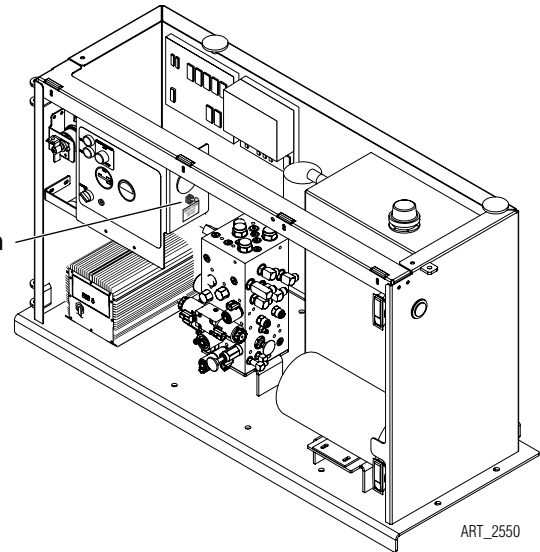
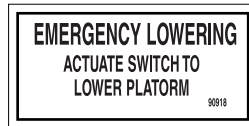

Limit Switch

The Limit switch indicates platform height above approximately 10 feet (3 m). When the platform is elevated above 10 feet (3 m) the limit switch is activated will;

- enable tilt sensor cutout operation
- lockout outriggers operation.
- reduce drive speed.

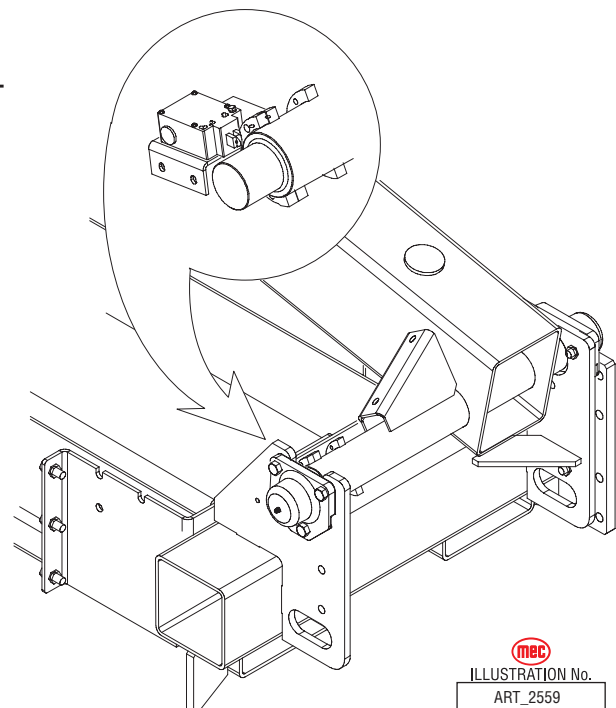

Movement Alarm

This alarm is activated as soon as the DOWN operation is activated from either station. This is the default setting. If desired, the movement alarm setting can be modified to activate the alarm during other functions (refer to *Section 4: Troubleshooting*).



THE MOVEMENT ALARM IS PROVIDED FOR YOUR PROTECTION, AND PROTECTION OF PERSONS WORKING IN THE IMMEDIATE AREA. DISABLING THIS IMPORTANT SAFETY DEVICE MAY RESULT IN SERIOUS INJURY OR DEATH.

Outrigger Stowed Switch (HD Models)

Each of the four outriggers has a “stowed” switch.

- Indicates full retraction of the outrigger cylinder.
- **Drive Function:** The machine will drive when the Outrigger Stowed switch on all four outriggers is engaged. If one or more Outrigger Stowed switch is open (not engaged) the machine *will not drive*.
- **Lift Function:** If one or more Outrigger Stowed switch is open (not engaged) the machine *will not lift* unless all four outriggers are fully deployed.

Outrigger Pressure Switch (HD Models)

Each of the four outriggers has a Pressure switch.

- Indicates full deployment of the outrigger.
- **Lift Function:** When deployment begins the Outrigger Stowed switches open and lift function is disabled. When all four outriggers reach full deployment the Outrigger Pressure switches close (engage) and lift function is restored.

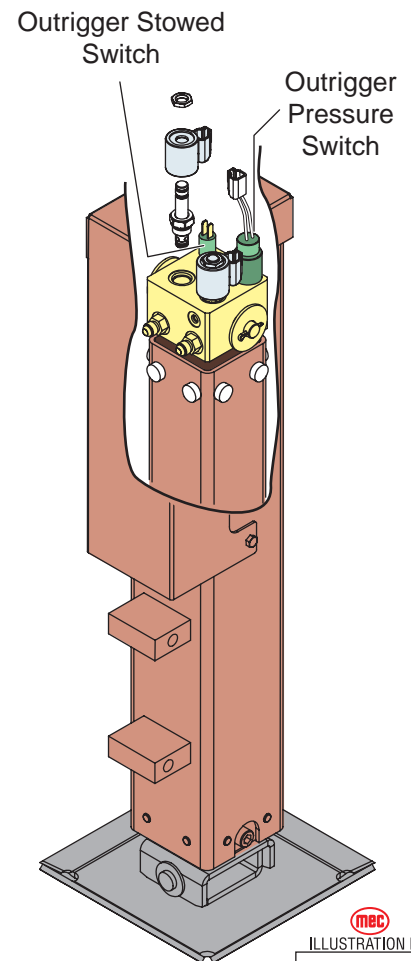
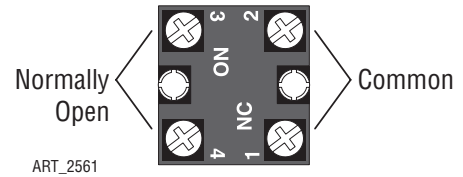

ILLUSTRATION No.
ART_2560

Continuity Checks

Check Key Switch – ON-OFF

- Disconnect wires.
- Connect first probe of ohm meter to *common* terminal.
- Connect second probe to any normally open terminal.
- With switch OFF (open) there should be no reading.
- With the switch ON (closed) there should be a low reading.
- Repeat for each normally open terminal.



Check Toggle Switch – ON-OFF

- Disconnect wires.
- Connect first probe of ohm meter to *common* terminal.
- Connect second probe to normally open terminal.
- With the switch turned OFF there should be no reading.
- With the switch turned ON there should be a low resistance.

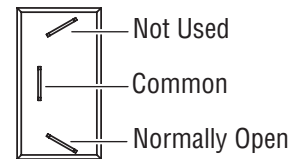
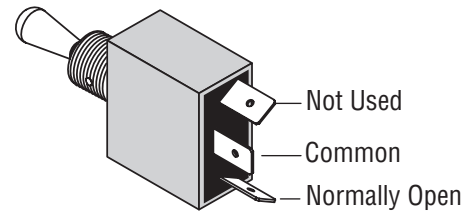

Check Toggle Switch – 1-Pole 2-Position

- Disconnect wires.
- Connect first probe of ohm meter to *common* terminal.
- Connect second probe to *top* normally open terminal.
- With toggle DOWN there should be no reading.
- With the toggle UP there should be a low resistance.
- Move second probe to bottom normally open terminal.
- With toggle UP there should be no reading.
- With the toggle DOWN there should be a low resistance.

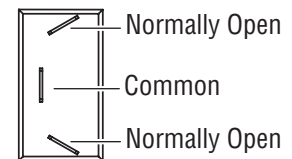
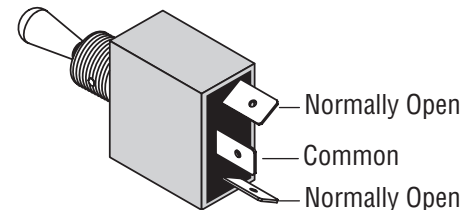

Check Toggle Switch – 1-Pole 3-Position

- Disconnect wires.
- Connect first probe of ohm meter to *common* terminal.
- Connect second probe of ohm meter to *top* terminal.
- With the toggle UP or MIDDLE there should be a low resistance.
- Move second probe to *bottom* terminal.
- With the toggle DOWN or MIDDLE there should be a low resistance.
- Connect first probe of ohm meter to *top* terminal.
- Connect second probe of ohm meter to *bottom* terminal.
- With toggle in ANY POSITION there should be no reading.

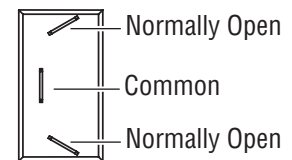
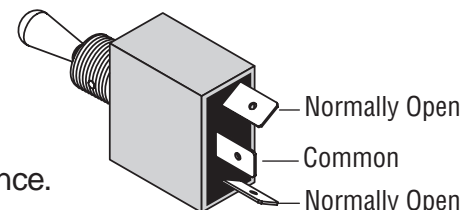

Check Toggle Momentary Switch

- Disconnect wires.
- Connect first probe of ohm meter to common terminal.

Test top position

- Connect second probe to *top* normally open terminal.
- With the toggle in the neutral (open) position there should be no reading.
- With the toggle UP (closed) there should be a low resistance.
- With the toggle DOWN (closed) there should be no reading.

Test bottom position

- Move second probe to *bottom* normally open terminal.
- With the toggle in the neutral (open) position there should be no reading.
- With the toggle DOWN (closed) there should be a low resistance.
- With the toggle UP (closed) there should be no reading.
- Repeat for both rows of two-row switch.

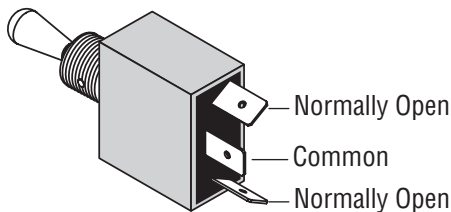

ART_2563

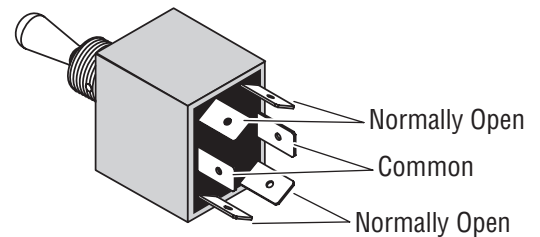
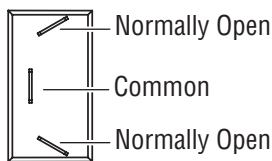

ART_2564

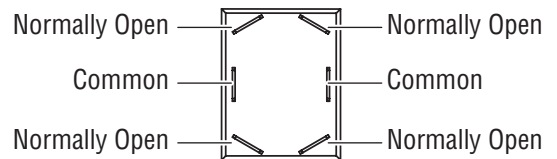

Check Momentary Button Switch

- Disconnect wires.
- Connect one probe of ohm meter each terminal.
- With the button in the neutral (open) position there should be no reading.
- With the button pushed (closed) there should be a low resistance.

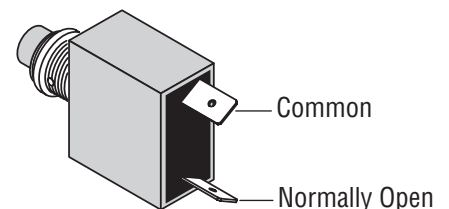

ART_2565

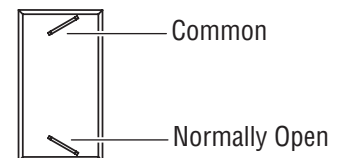

Check Emergency Stop Button

- Disconnect wires.
- Connect one probe of ohm meter each terminal.
- With the button PRESSED there should be no reading.
- With the button RESET there should be a low resistance.

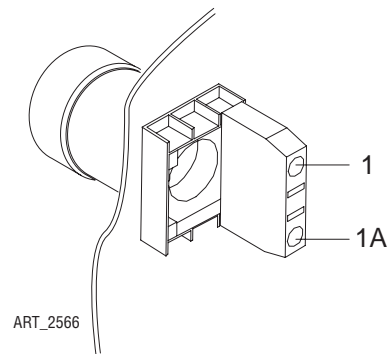

Check Limit Switch Operation

- Disconnect wires.
- With one probe of ohm meter to common and other probe to open contact, move limit switch arm. Low resistance should be seen.
- With one probe of ohm meter to common and other probe to closed contact, low resistance should be seen. Move limit switch arm and no resistance should be seen.

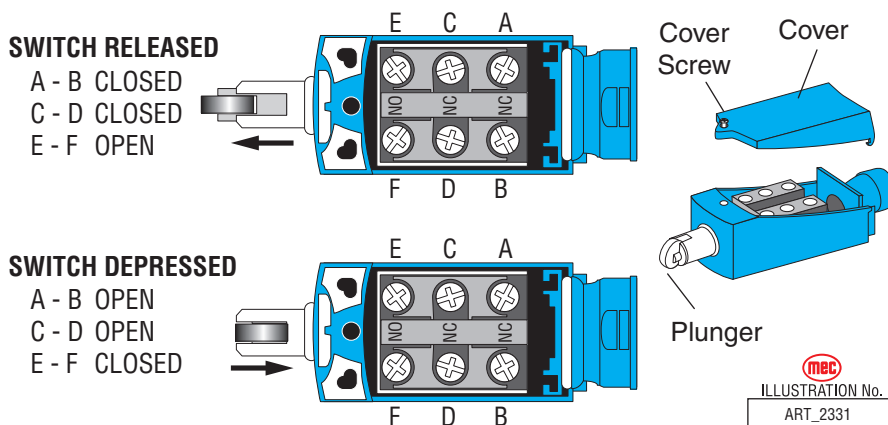

Motor Controller

The Petronic GP400 Processor and GP600 Motor Speed Controller are located in the control module behind the lower controls. The GP400 Matrix Module is located in the upper control box. Diagnostic information *can be found in Section 4: Troubleshooting*. Wiring information can be found in *Section 5: Schematics*.





SECTION 3







MECHANICAL COMPONENTS

Torque Specifications	3-2
Base / Undercarriage	3-3
Hoses and Cables	3-3
Raising the Machine	3-4
Tires/Wheels	3-5
Changing Tires/Wheels	3-5
Drive Motors	3-6
Front Drive Motors	3-6
Rear Drive Motor with Brakes	3-6
Steer Cylinder	3-7
Platform Removal	3-8
Lift Cylinder Removal and Installation	3-9
Scissor Beam Assembly	3-10
Outrigger Function	3-11

TORQUE SPECIFICATIONS

Fasteners

Use the following values to apply torque unless a specific torque value is called out for the part being used.

AMERICAN STANDARD CAP SCREWS								METRIC CAP SCREWS									
SAE GRADE	5				8				METRIC GRADE	8.8				10.9			
CAP SCREW SIZE - inches -									CAP SCREW SIZE - millimeters -	 				 			
	TORQUE				TORQUE					TORQUE				TORQUE			
	FT. LBS		Nm		FT. LBS		Nm			FT. LBS		Nm		FT. LBS		Nm	
	MIN	MAX	MIN	MAX	MIN	MAX	MIN	MAX		MIN	MAX	MIN	MAX	MIN	MAX	MIN	MAX
1/4 - 20	6.25	7.25	8.5	10	8.25	9.5	11	13	M6 X 1.00	6	8	8	11	9	11	12	15
1/4 - 28	8	9	11	12	10.5	12	14	16	M8 X 1.25	16	20	21.5	27	23	27	31	36.5
5/16 - 18	14	15	19	20	18.5	20	25	27	M10 X 1.50	29	35	39	47	42	52	57	70
5/16 - 24	17.5	19	23	26	23	25	31	34	M12 X 1.75	52	62	70	84	75	91	102	123
3/8 - 16	26	28	35	38	35	37	47.5	50	M14 X 2.00	85	103	115	139	120	146	163	198
3/8 - 24	31	34	42	46	41	45	55.5	61	M16 X 2.50	130	158	176	214	176	216	238	293
7/16 - 14	41	45	55.5	61	55	60	74.5	81	M18 X 2.50	172	210	233	284	240	294	325	398
7/16 - 20	51	55	69	74.5	68	75	92	102	M20 X 2.50	247	301	335	408	343	426	465	577
1/2 - 13	65	72	88	97.5	86	96	116	130	M22 X 2.50	332	404	450	547	472	576	639	780
1/2 - 20	76	84	103	114	102	112	138	152	M24 X 3.00	423	517	573	700	599	732	812	992
9/16 - 12	95	105	129	142	127	140	172	190	M27 X 3.00	637	779	863	1055	898	1098	1217	1488
9/16 - 18	111	123	150	167	148	164	200	222	M3 X 3.00	872	1066	1181	1444	1224	1496	1658	2027
5/8 - 11	126	139	171	188	168	185	228	251									
5/8 - 18	152	168	206	228	203	224	275	304									
3/4 - 10	238	262	322	255	318	350	431	474									
3/4 - 16	274	302	371	409	365	402	495	544									
7/8 - 9	350	386	474	523	466	515	631	698									
7/8 - 14	407	448	551	607	543	597	736	809									
1 - 8	537	592	728	802	716	790	970	1070									
1 - 14	670	740	908	1003	894	987	1211	1137									

Torque values apply to fasteners as received from the supplier, dry or when lubricated with normal engine oil.
If special graphite grease, molydisulphide grease, or other extreme pressure lubricants are used, these torque values **do not apply**.

Hydraulic Components

Use the following values to apply torque to hydraulic components. Always lubricate threads with clean hydraulic fluid prior to installation.

TYPE: SAE PORT SERIES	FITTINGS		HOSES	
	FT. LBS.	Nm	FT. LBS.	Nm
#4	9 - 11	12 - 15	16 - 18	22 - 24
#6	19 - 24	25 - 32	28 - 32	38 - 43
#8	39 - 42	53 - 57	38 - 42	52 - 57
#10	58 - 62	78 - 84	58 - 62	79 - 84
#12	79 - 85	107 - 115	83 - 87	113 - 118
#16	136-144	184 - 195	100 - 110	136 - 149

BASE / UNDERCARRIAGE



When steam cleaning the base/ undercarriage, cover electrical components to prevent water penetration.



DO NOT POWER WASH OR SPRAY ELECTRONIC COMPONENTS OR CONNECTORS. MOISTURE MAY CAUSE DAMAGE AND/OR ERRATIC OPERATION.

Steam clean the base as necessary, and inspect all welds and brackets. Check for cylinder pins that turn in their mounting, which will indicate sheared retaining pins.

HOSES AND CABLES

Note: Refer to *Parts Section E* for detailed hydraulic hose diagrams.

Inspect all hoses and electrical cables for security and damage. Hoses and cables should be examined for rubbing and chafing.

Check for leaks at fittings. Replace any damaged hose or cable.

1. Tag hoses for proper reassembly.
2. Disconnect hoses and IMMEDIATELY cap the openings to prevent contamination.
3. Torque hose fittings according to the Hydraulic Torque Specification Table.

RAISING THE MACHINE



THE USE OF SUBSTANDARD LIFTING DEVICES AND/OR JACK STANDS MAY CAUSE THE MACHINE TO FALL RESULTING IN DEATH OR SERIOUS PERSONAL INJURY.

The following are needed to safely raise and support the machine;

- a jack with a lifting capacity of two (2) tons or more.
- jack stands with a rating of one (1) ton or more.

To raise the machine

1. Move machine to a firm level surface capable of supporting the weight of the machine.
2. Chock tires on one end of machine and raise the other end of machine.
3. Position a jack at the end of the machine to be lifted, under a solid lifting point in the center of the frame.
4. Raise the machine and place two (2) suitable jack stands under solid support points at the outer ends of the frame.
5. Lower the machine to rest on the jack stands and inspect for stability.

To lower the machine

1. Raise machine slightly and remove jack stands.
2. Lower the machine and remove the jack.
3. Remove chocks.

TIRES/WHEELS

Inspect for cuts, chunking, side-wall damage, or abnormal wear. *Any tire faults must be corrected before further machine operation.* Refer to *Parts Section* for replacement tires.



FAILURE TO USE APPROVED PARTS CAN CAUSE DEATH OR SERIOUS PERSONAL INJURY.

NOTE: Replace tires/wheels with the correct tires to maintain the rating of this equipment.

Changing Tires/Wheels



FOAM FILLED TIRES ARE EXTREMELY HEAVY. CARE MUST BE TAKEN TO AVOID PERSONAL INJURY.



Always block the wheels before raising the machine.

When a tire change is necessary, follow these tips:

1. While the machine is on the ground, loosen but **do not remove** lug nuts.

NOTE: Wheels may spin when attempting to loosen lug nuts without the weight of the machine on the wheels. Loosen lug nuts enough to break free, but leave them tight for safety.

2. Raise and support the machine (see *Raising the Machine*).
3. Remove lug nuts and pull the wheel off.
4. Install the replacement wheel and tighten the lug nuts.
5. Lower the machine to the ground.
6. Torque lug nuts to 75 to 85 ft.-lbs. (102 to 115 Nm).

DRIVE MOTORS

There are two (2) hydraulic motors on the front axle and two (2) drive motor brakes on the rear drive axle. These can be damaged or leaks may occur; repair or replace as necessary.

CAUTION

- Clean all fittings before disconnecting hoses.
- Tag hoses for proper reassembly.
- Plug all openings to prevent contamination.

Front Drive Motors

Remove

1. Raise and support the front end of machine (see *Raising the Machine*).
2. Remove the wheel and tire assembly to access drive motor.
3. Remove the hub from the drive motor shaft.
4. Disconnect the cylinder end and tie-rod from the motor housing.
5. Turn the motor housing to gain access to the motor and hose assemblies.
6. Disconnect hose assemblies from drive motor and cap them.
7. Remove the cap screws and remove the drive motor.

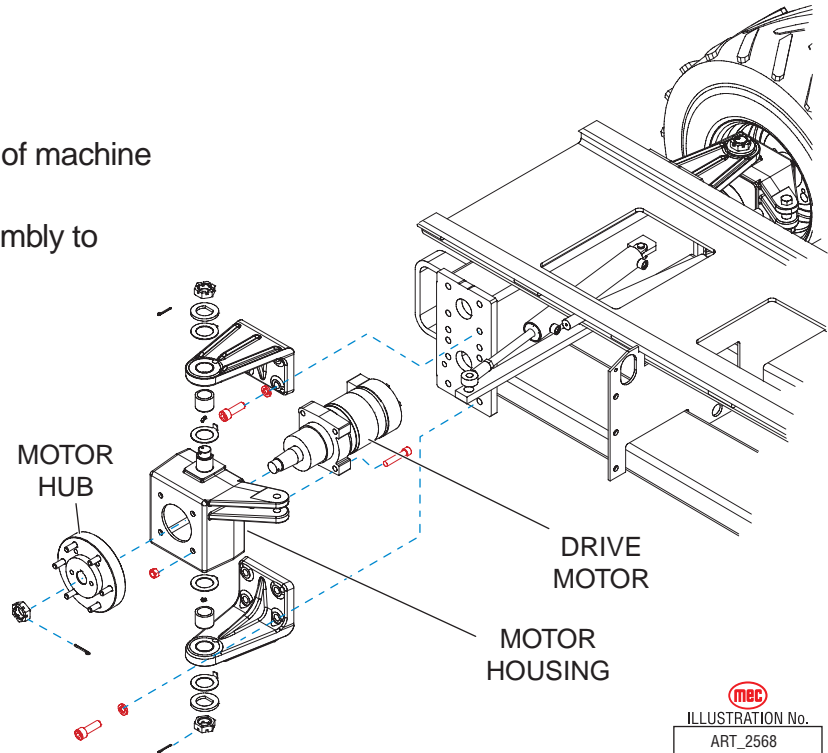

Replace

Installation is reverse of removal.

Rear Drive Motor with Brakes

Remove

1. Raise and support the rear end of machine (see *Raising the Machine*).
2. Remove the wheel and tire assembly to access drive motor.
3. Disconnect hose assemblies from drive motor and cap them.
4. Remove the relief valve.
5. Remove the cap screws and remove the drive motor from the housing.

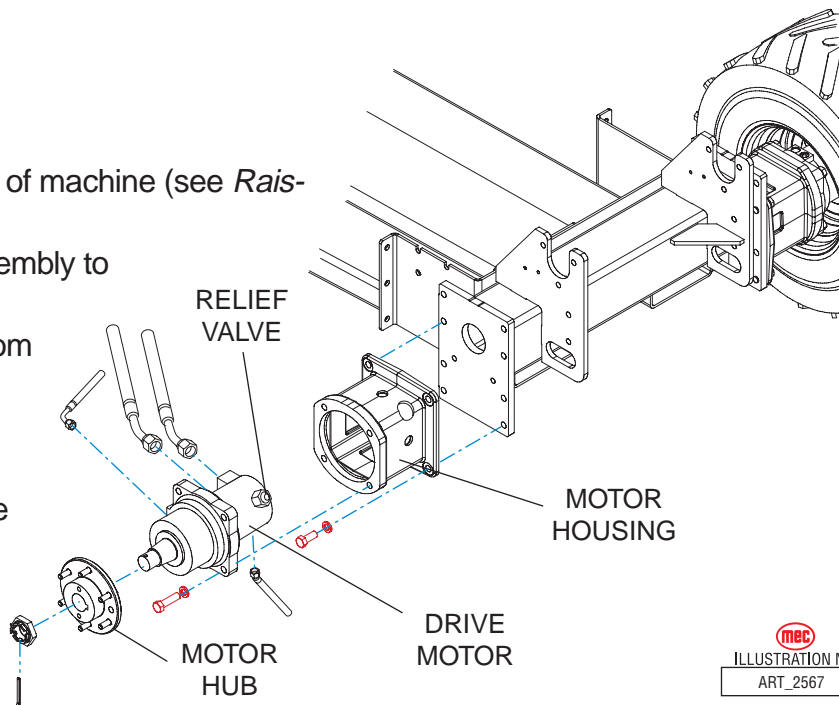

Replace

Installation is reverse of removal.

STEER CYLINDER

There are two (2) cylinders utilized in the steering system. These cylinders are a double acting type which requires fluid flow to operate the cylinder rod in both directions. During operation, the cylinders should not leak, but a slight damping at the rod seal is acceptable. The pins should be checked for wear.

To replace steer cylinder:

CAUTION: • Clean all fittings before disconnecting hoses.

- Tag hoses for proper reassembly.
- Plug all openings to prevent contamination.

1. Raise and support the front end of machine (see *Raising the Machine*).
2. Disconnect hydraulic hoses and cap them.
3. Remove the nut and bolt holding the steer cylinder to the motor mounting bracket.
4. Remove the pin and cotter pin holding the steer cylinder to the steer axle tie-rod.
5. Carefully lift off the steer cylinder.
6. Position the new steer cylinder and install pin and cotter pin to hold cylinder to the steer axle tie rod.
7. Install nut and bolt to hold cylinder to motor mounting bracket.
8. Connect hydraulic hoses.
9. To purge air from cylinder;
 - place a suitable container beneath the hose connections to catch spilled fluid,
 - loosen hose fittings slightly,
 - actuate steer function,
 - when all air is purged, tighten hose connections.

Steer Cylinder Seal Replacement

Refer to *Section 1: Cylinder Repair* for seal replacement instructions.

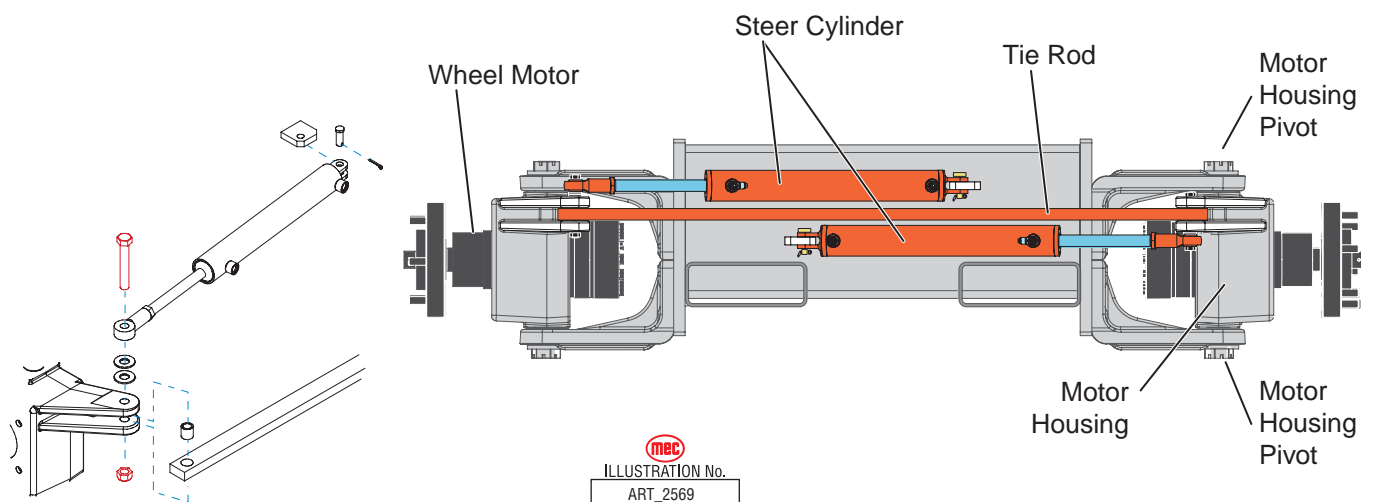

PLATFORM REMOVAL

1. Raise platform and support with the maintenance lock.
2. Connect overhead crane by appropriate lifting device to platform.
3. Remove the terminal strip cover and disconnect all platform wires. Remove any components that will obstruct the scissor slide path.
4. Remove the bolts from both fixed blocks at the rear of the platform.
5. Lift the rear of the platform until the fixed blocks are clear.
6. Slide the platform assembly forward until the slide blocks align with the slide track opening at the rear of the platform.
7. Remove the platform assembly.
8. Installation is reverse of removal.

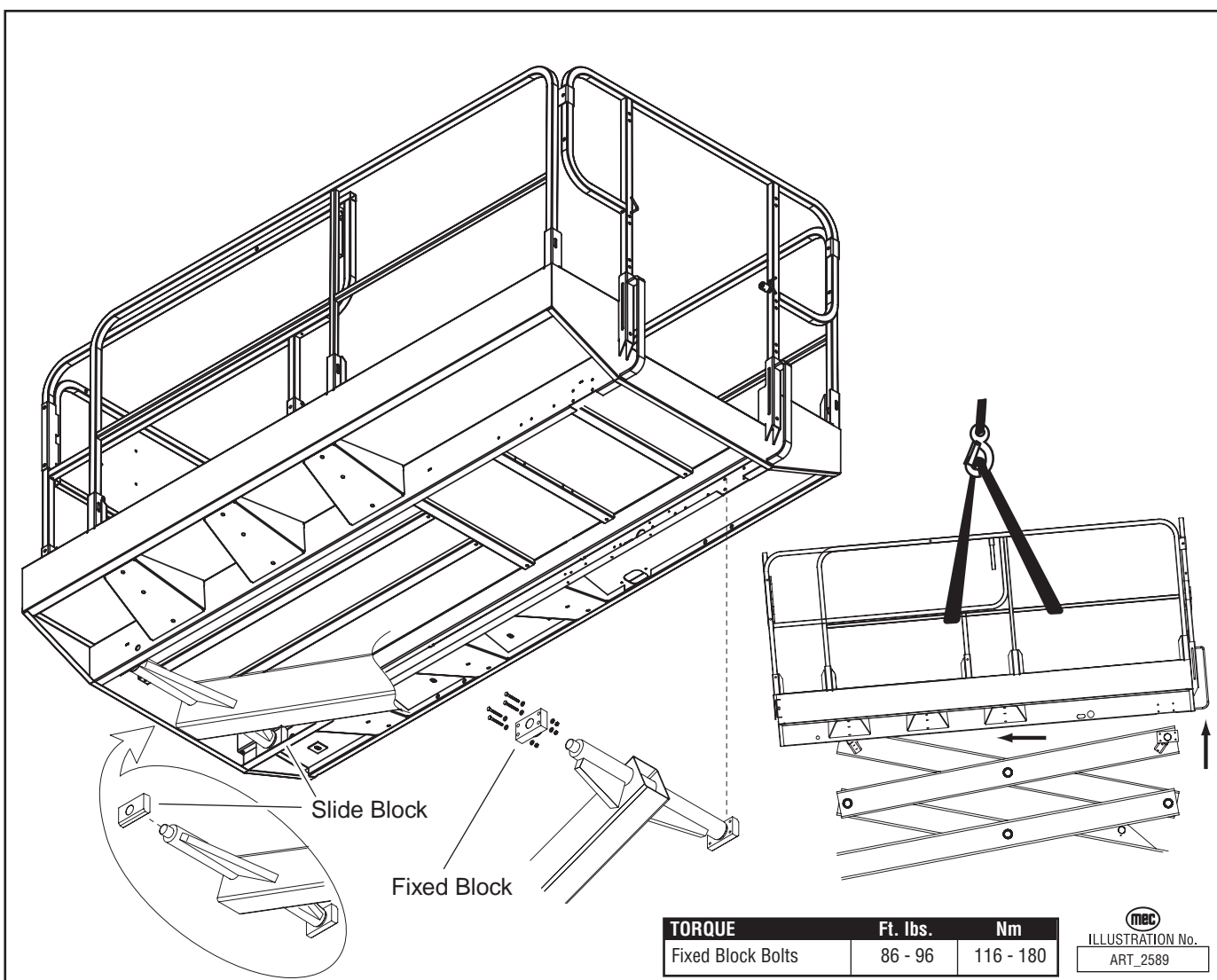

LIFT CYLINDER REMOVAL AND INSTALLATION

Note: Refer to *Section 1* for seal replacement instructions.
Refer to *Parts Section C* for detailed parts list and illustration.

CAUTION

- Clean all fittings before disconnecting hoses.
- Tag hoses for proper reassembly.
- Plug all openings to prevent contamination.

1. Raise the scissor arm assembly and support using the maintenance lock.
2. Remove the support beam.
 - Remove the upper and lower retaining rings.
 - Remove the upper and lower nylon washers.
3. Disconnect hoses and wires and cables from the lift cylinder(s).
4. Use a suitable lifting device to support the lift cylinder.

CAUTION

Attach the lifting device to the cylinder body. Lifting by the rod end will cause the cylinder to extend.

5. Remove the upper retaining plate, cylinder mount pin, and two (2) nylon washers.
6. Remove the lower retaining plate.
7. While supporting the cylinder, carefully remove the cylinder mount pin and two (2) nylon washers.

CAUTION

The cylinder may shift suddenly when the pin is removed.

8. Lift the cylinder from the scissor assembly using a suitable lifting device.
9. Clean all parts before reassembly. Replace worn or damaged parts with new parts.
10. Installation is reverse of removal.

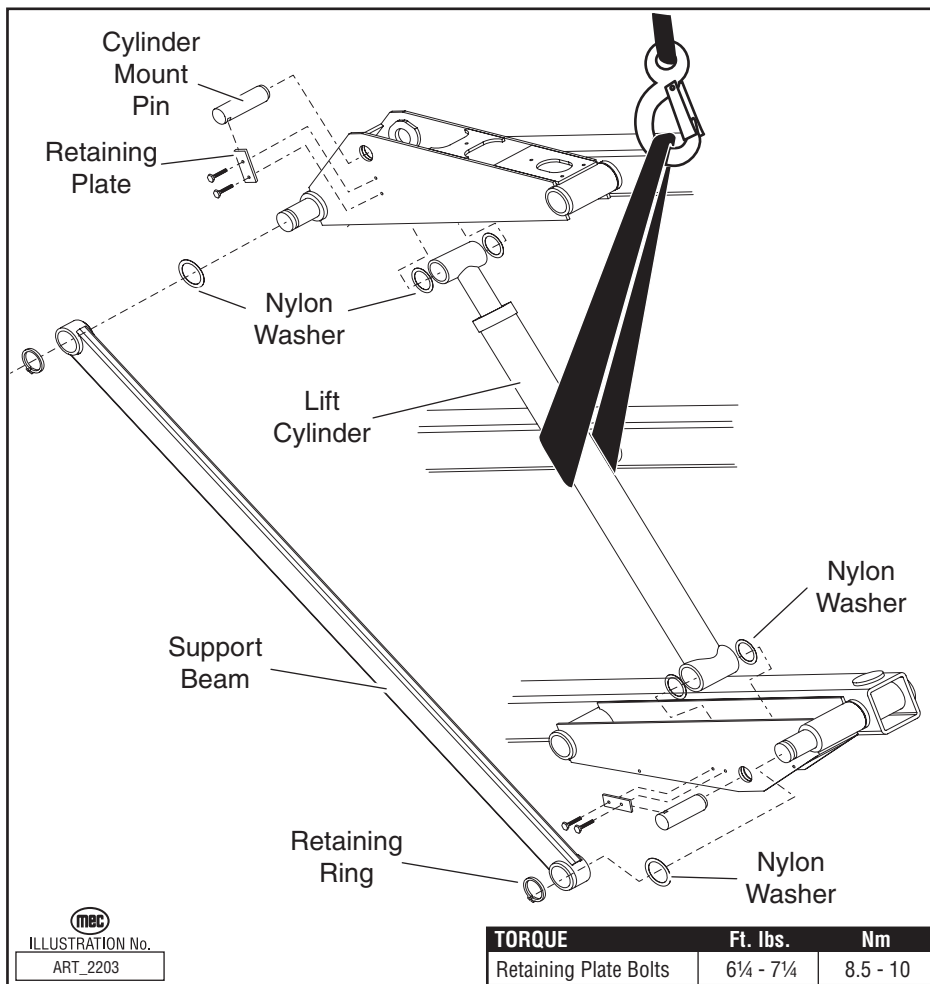

SCISSOR BEAM ASSEMBLY

Note: Refer to *Parts Section C* for detailed parts list and illustration.

Clean the scissor assembly once a year or as necessary and inspect along the beam surfaces, especially the welds and brackets.

CAUTION

- Clean all fittings before disconnecting hoses.
- Tag hoses for proper reassembly.
- Plug all openings to prevent contamination.

Scissor Beam Removal

1. Remove the platform and ladder.
2. Disconnect hoses and wires and cables
3. Attach a suitable lifting device to the scissor assembly.
4. Remove the Limit Speed switch cover.
5. Remove the bolts from the Limit Speed switch bracket and move the switch and bracket out of the way.
6. Remove the stationary mounts.
7. Carefully lift until the rear of the scissor assembly is clear.
8. Slide the scissor assembly to the front until the slide blocks exit the end of the slide track.



CAUTION

The scissor assembly may shift suddenly upon clearing the slide track.

9. Lift the scissor assembly.
10. Remove slide blocks, bearings, and wear pads.
11. Clean all parts before installation. Replace worn or damaged parts with new parts.
12. Installation is reverse of removal.

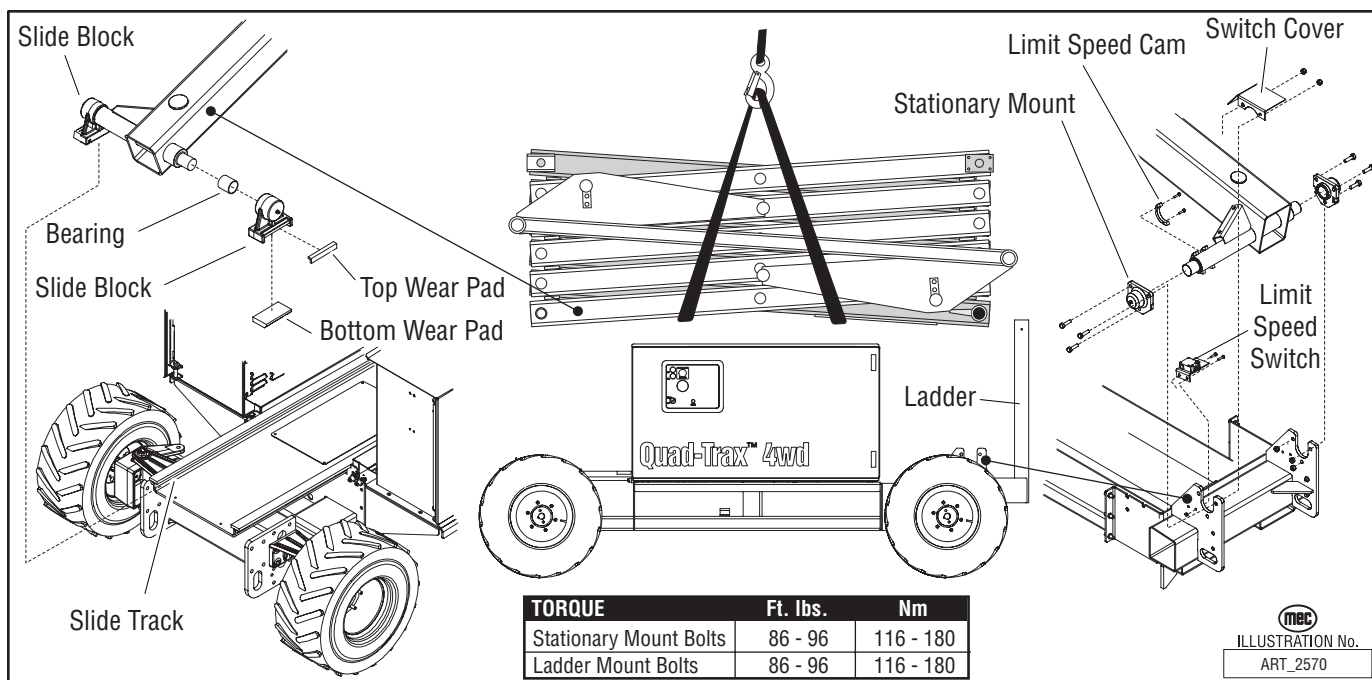

OUTRIGGER FUNCTION

The optional outriggers on MEC Scissor Lifts are a One-Touch Activation system. To deploy the outriggers, simply push the outrigger toggle switch down until the outriggers level the unit and the engine returns to idle. You are now ready to lift the platform. The outrigger control module is a “smart” unit, which will level the unit in all but extreme terrain so you don’t have to attempt to level it yourself.

Operational Characteristics

- To deploy the outriggers, push the Outrigger Switch down and hold until the electric motor stops. The unit will self-level.
- The outrigger legs can not be operated individually.
- The outriggers system will not operate when the platform is elevated above approximately 10 feet (3 m).
- Travel is locked out when the outriggers are deployed. A Drive Indicator Light, above the outrigger switch, will illuminate when the outriggers are fully retracted.
- The electric motor will turn off when the outriggers are fully retracted and the drive indicator light will signal that the outriggers are fully retracted.
- If the slope of the terrain is in excess of the outrigger’s leveling capabilities, the outrigger control system will continue to attempt to level and the electric motor will not turn off. In this case, if the platform remains outside of the pre-described tilt sensor parameters, the unit will not elevate above 6 feet (2 m) and the alarm will sound, indicating the out-of-level situation.
- The outrigger system uses a Top-out limit switch and a Pressure switch on each leg to monitor their respective positions.
- Each outrigger leg uses a Retract valve and an Extend valve to control cylinder stroke. These are located under the protective cover atop the outrigger leg.
- A 4-way, 3-position valve, on the outrigger hydraulic manifold controls the direction of fluid flow to the outrigger legs.
- The GP400 Control Module controls all outrigger valve and interlock duties as well as sensing unit level.
- Diagnosis of the GP400 Control Module is possible by counting the number of flashes from the red LED and referring to *Section 4: Troubleshooting*. Diagnosis and calibration of the GP400 module can also be done through the use of the EZ-Cal scan tool MEC part # 90888. (See *Section 4: Troubleshooting*).





SECTION 4

TROUBLESHOOTING

General Troubleshooting Tips	4-2
Electrical System Troubleshooting	4-4
EZ-Cal Scan Tool	4-8
EZ-Cal Adjustment	4-14
EZ-Cal Setup	4-16
EZ-Cal Diagnostics	4-17
EZ-Cal Outrigger Test Mode	4-18
Retrieve Mode And Help Messages From The Ez-Cal	4-21
EZ-Cal HELP Messages	4-24
Trouble Table	4-30
Hydraulic Pressure Adjustment Procedures	4-35
Troubleshooting Battery Charger	4-38

GENERAL TROUBLESHOOTING TIPS

The 3072ES and 3772ES Aerial Work Platforms operate on a "Motor Control" theory in which fluid flow volume is controlled by varying the speed of the DC electric motor. 100% of the fluid produced by the pump goes to the selected function.

Battery Charge State

Before you begin troubleshooting this model, check the battery state of charge and inspect the battery connections for looseness or corrosion. A fully charged battery pack on a 48 Volts DC system will have a nominal voltage of 52.5–54 Volts DC.

Common Causes of Electrical System Malfunctions:

- Battery switch is turned OFF (located to the left of lower controls).
- Battery connections are loose or corroded
- Battery is not fully charged.
- Emergency Stop buttons are pushed (OFF position).
- Circuit breaker is in the tripped (OFF position).

Common Causes of Hydraulic System Malfunctions:

- Hydraulic fluid level is too low.
- Incompatible hydraulic fluids mixed, destroying the additives and causing varnish build up, resulting in the valves sticking.
- Water in the hydraulic fluid due to a damp climate.
- Improper hydraulic fluid used. Viscosity too high in cold climates. Viscosity too low in warm climates.
- Hydraulic fluid contaminated with debris - filter change interval neglected.

NOTES: ISO Grade 32 hydraulic fluid, is a multiple viscosity fluid that is light enough for cold climates and resists thinning in warm climates. Only ISO Grade 32 or equivalent must be used.

Contamination always causes failure in any hydraulic system. It is very important to be careful not to introduce any contamination into hydraulic system during the assembly procedures. Please make sure all ports and cavities of the manifold and cylinders are properly covered/plugged during maintenance activities.

Refer to the accompanying illustrations when using the Troubleshooting Guide.

Hydraulic Manifold

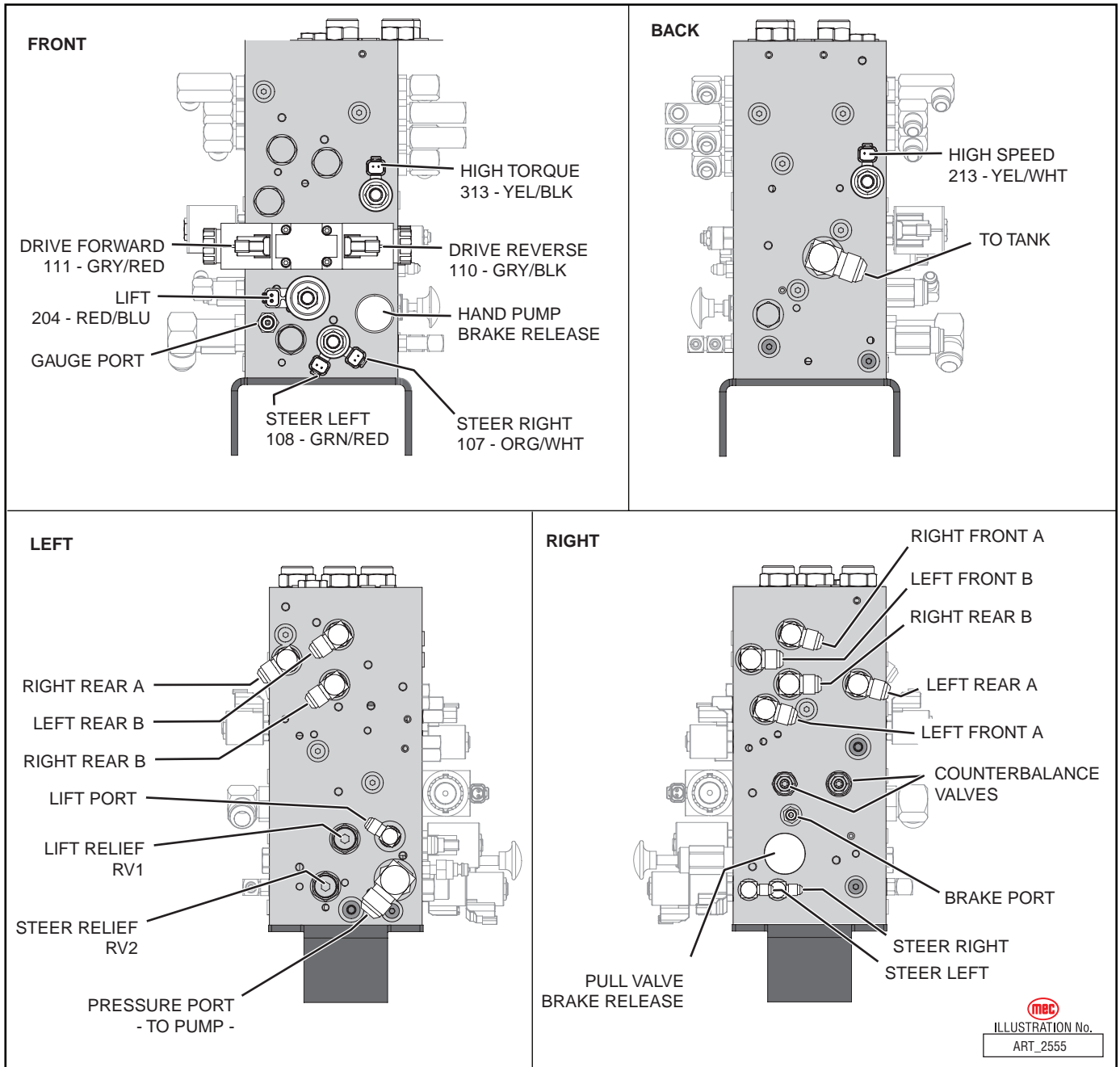

ELECTRICAL SYSTEM TROUBLESHOOTING

The electronic control system used on the 3072ES and 3772ES is designed for very low maintenance and long trouble free operation. All wire harness plug connections are waterproof to avoid moisture related problems that can lead to short terminal life. The system consists of three electronic microprocessor controlled modules; the Matrix Module, P600 Motor Control Module and the GP400 Processor. The modules communicate through low voltage digital signal technology called **CAN bus** communication.

The modules are protected against short circuit and reverse polarity to protect against part failure or incorrect plug connections.



NEVER ATTEMPT TO SUPPLY BATTERY POWER, OR VOLTAGE HIGHER THAN 12 VOLTS TO ANY PART OR MODULE IN THIS SYSTEM, CATASTROPHIC FAILURE OF THE MODULES MAY RESULT.

USE OF HIGH PRESSURE WASHING EQUIPMENT IN THE VICINITY OF THE MODULES CAN CAUSE THE SYSTEM TO STOP OPERATING AND IS HIGHLY DISCOURAGED.

Matrix Module

Located inside the upper control box, the Matrix Module receives inputs from upper control switches and communicates them to the GP400.

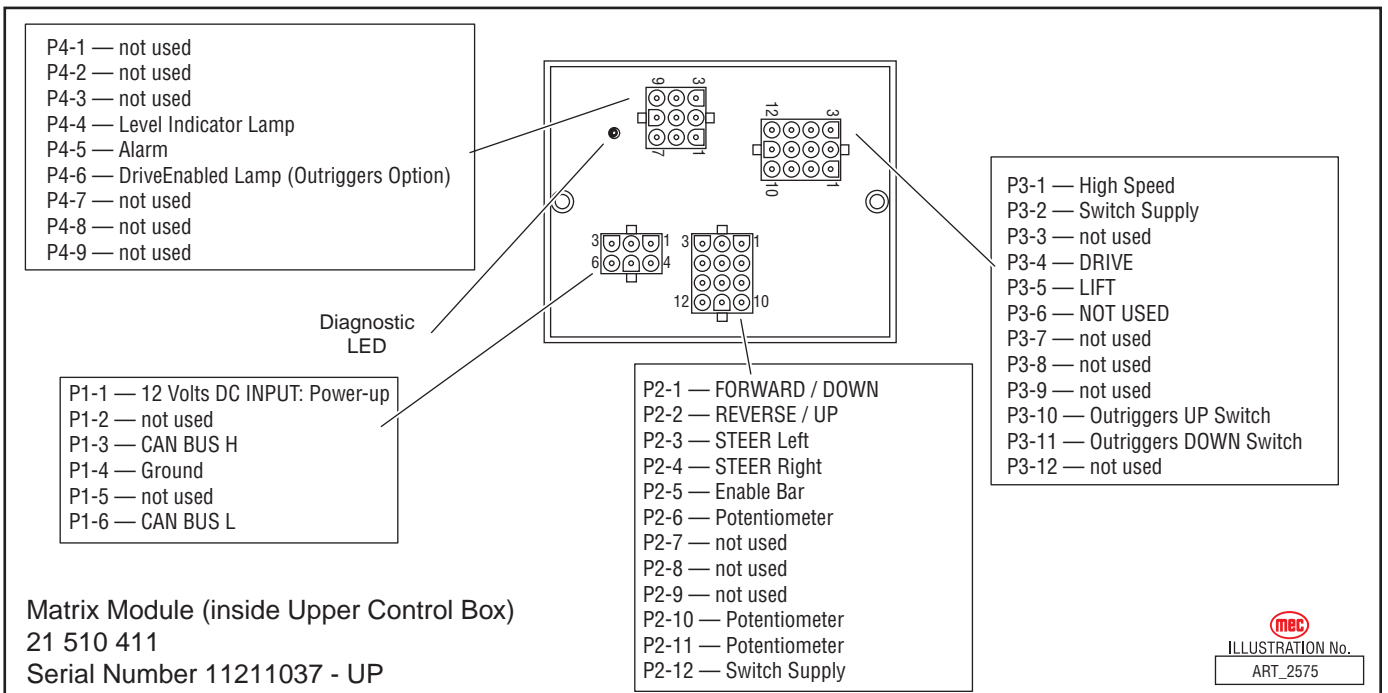
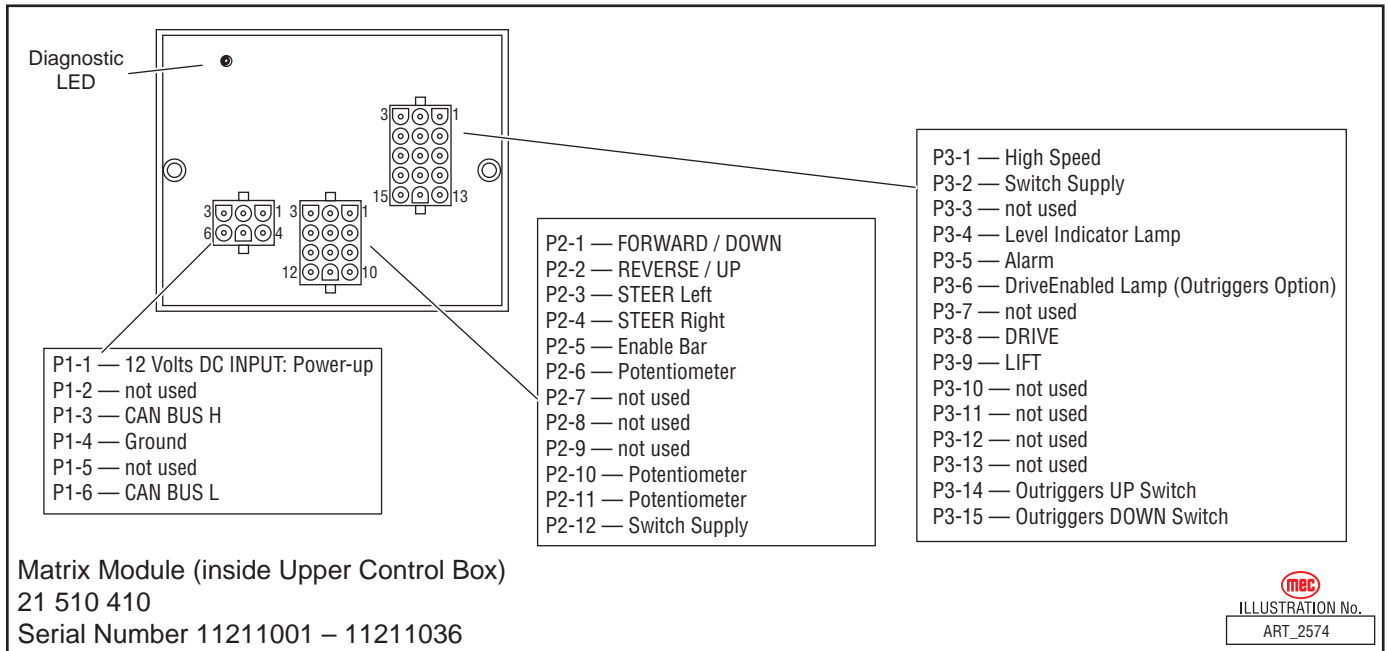

P600 Motor Control Module

The Motor Control Module operates the electric pump motor with varied speeds depending on operator commands. Pulse-width Modulation provides smooth and controlled operation with maximum battery efficiency. The Motor Controller also converts battery voltage (48 volts DC) to the user-friendly 12 volts DC used throughout the rest of the system.

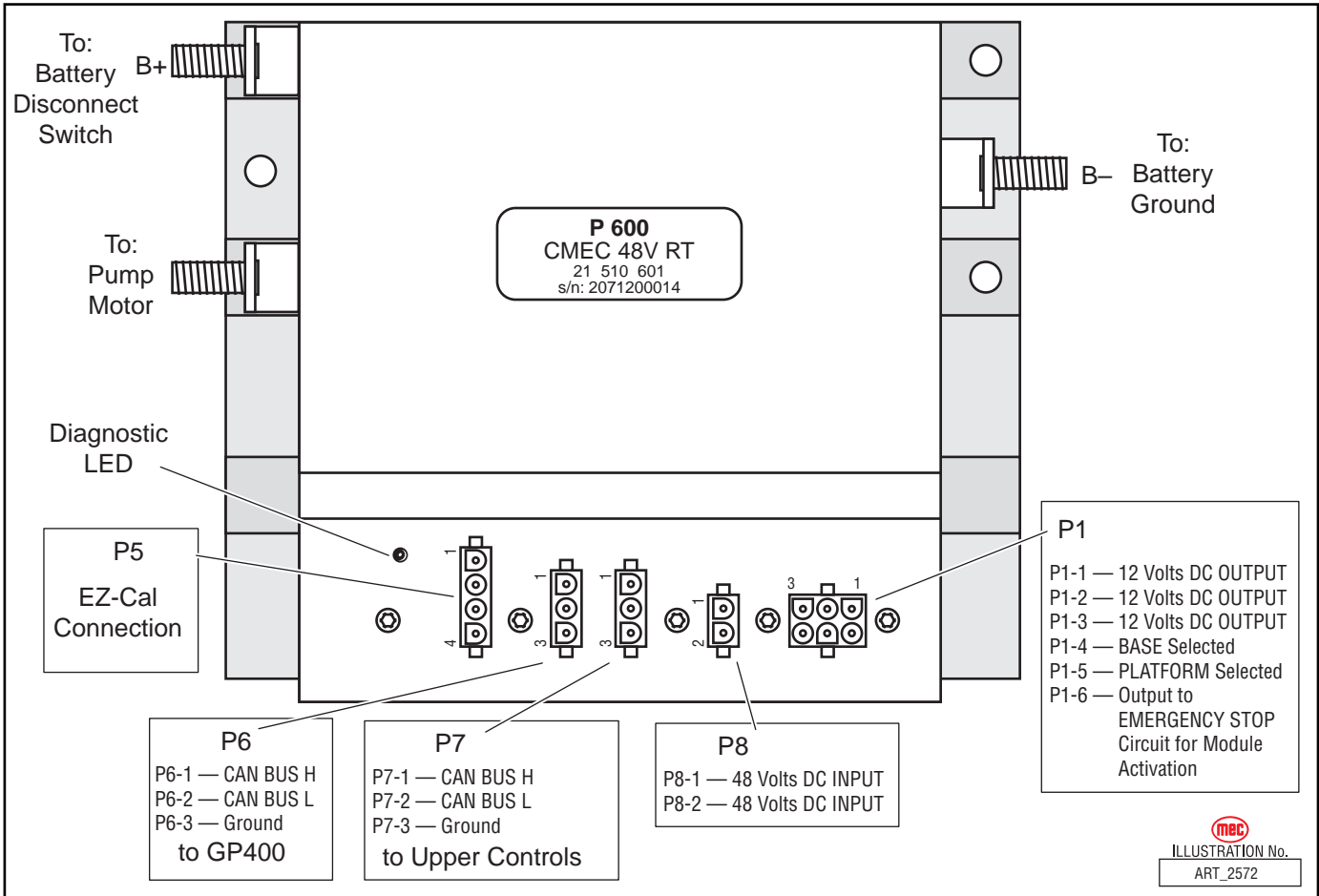

GP400 Module

The GP400 Module sends, receives and processes inputs from the Motor Control and Matrix modules, then controls output function. Communication between the three modules is achieved through the use of CAN bus communication link.

The GP400 was designed with the technician in mind. Through the use of the EZ-Cal interface tool, it allows the technician to make adjustments to various personalities, monitor inputs and outputs in real time, plus access informational messages for both current and recent events. A complete list of EZ-Cal messages can be found on the following pages.

The GP400 operates on 12 volts DC and should never be probed or operated with voltage higher than 14 volts DC.

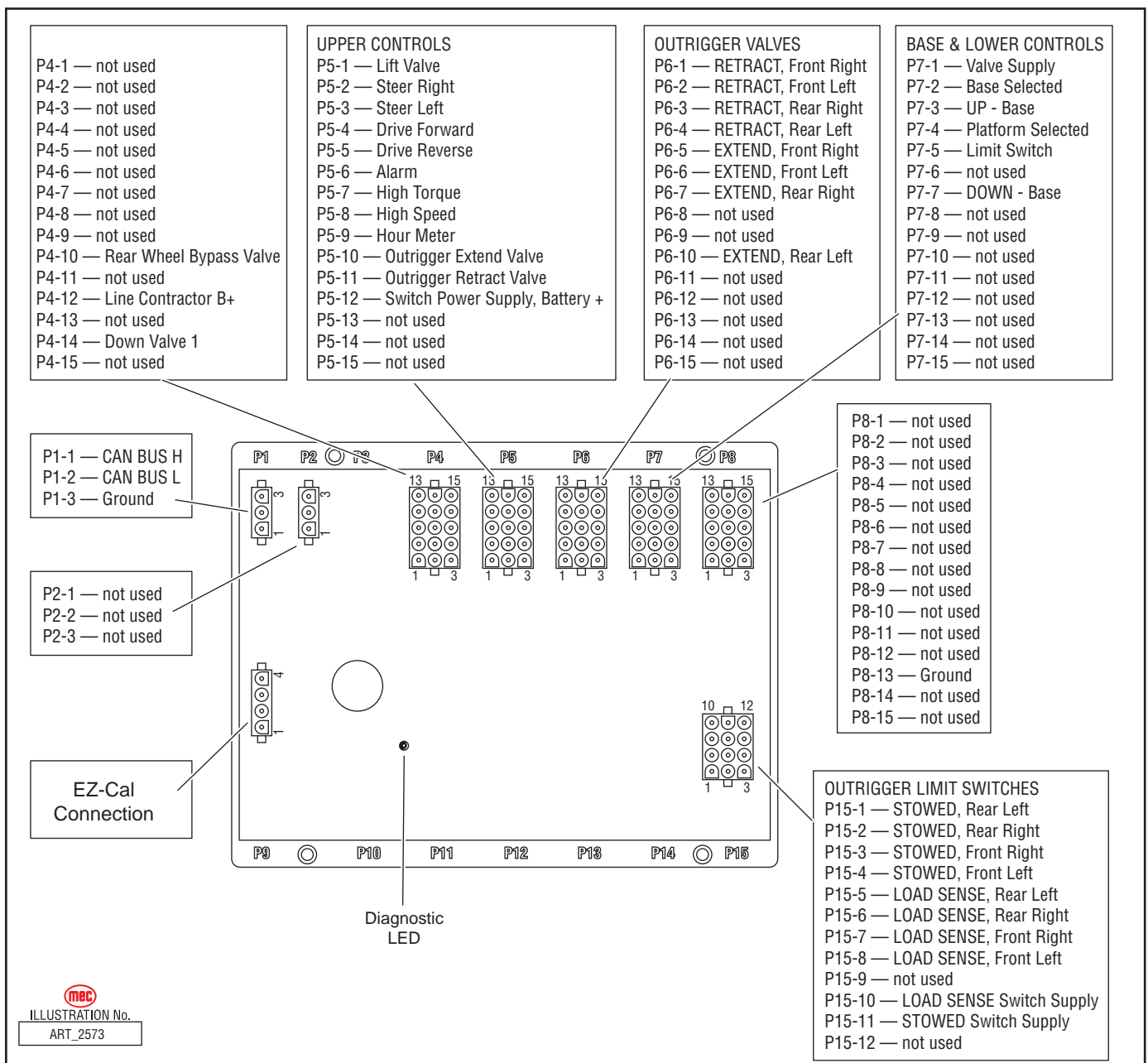

EZ-CAL SCAN TOOL

The **EZ-Cal** is a hand-held interface tool that communicates with the GP400 processor to provide troubleshooting information and adjustments. The EZ-Cal receives its power from the GP400 when connected. It also conveniently provides back-lighting to the display.

EZ-Cal Operation

The system must be powered up to use the EZ-Cal. To power the system up;

- put the battery disconnect switch in the ON position
- reset the Base and the Platform emergency stop switches
- at the upper controls, turn the key switch to ON
- at the lower controls, select the station you will operate from (Base or Platform).

To operate the EZ-Cal, plug the cable into the open 4-terminal receptacle on the GP400 and power the system up.

- The EZ-Cal display will illuminate and read "HELP: PRESS ENTER". From this point, use the right and left arrows to scroll through the base menus.
- Once the desired base menu is obtained press Enter to access sub menu.
- Use the right and left arrows to scroll through sub menus, press Enter again.
- The up/down arrows are used to change settings.
- Press ESC to go back one level.

The EZ-Cal Flow Chart on page 4-10 through page 4-13, and the EZ-Cal Tables beginning on page 4-14 will help to quickly locate diagnostic and adjustments information.

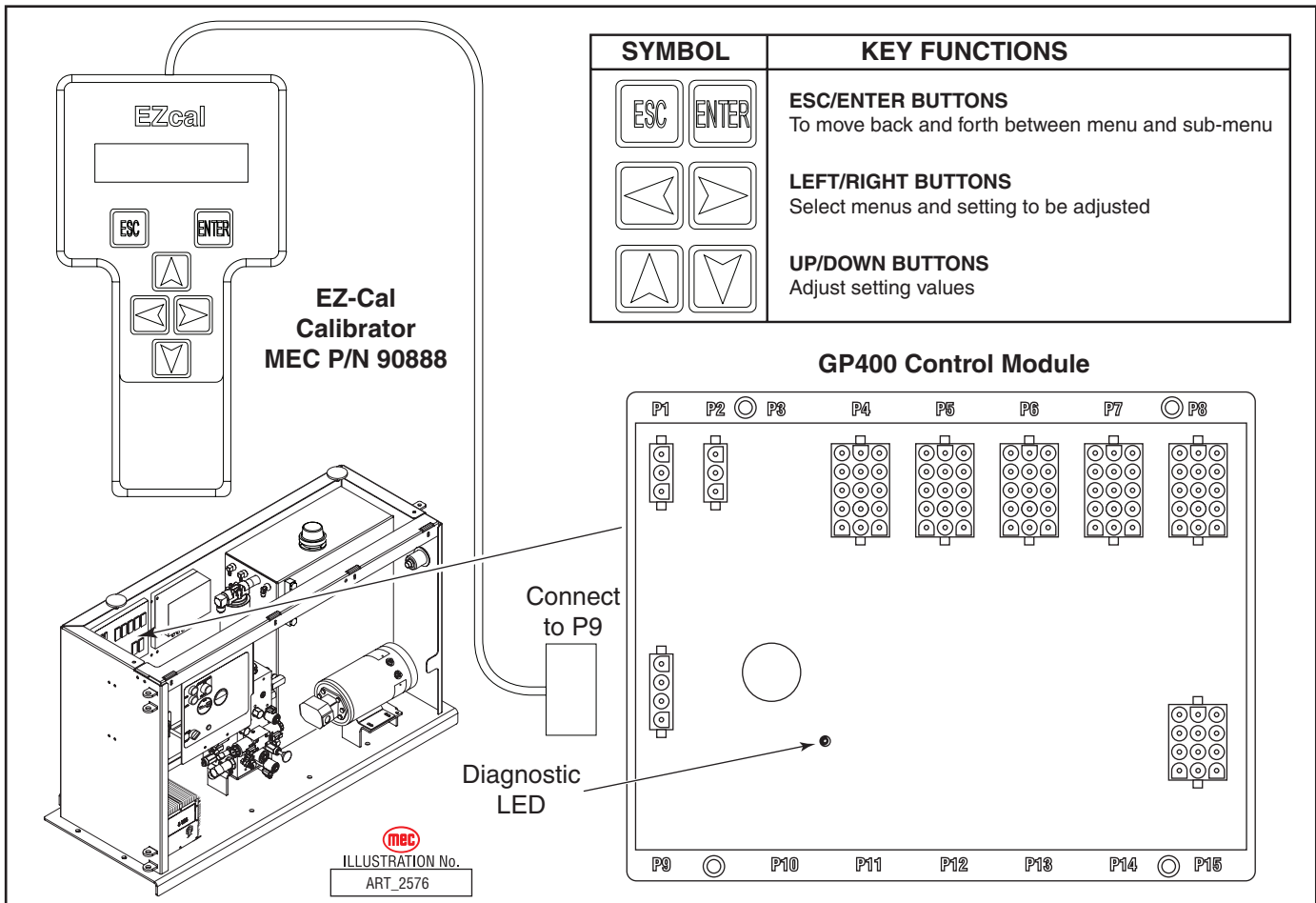

Using the EZ-Cal with the Flow Charts

Use the EZ-cal Flow Charts on page 4-10 through page 4-13 as a guide to locate diagnostic information and make adjustments. Each box in the flow chart will have 3 bits of information.

The IDENTIFIER (5c2): Used to locate this specific personality in the informational charts. Here you can obtain specific information on the individual personalities.

The PERSONALITY (Up Max): Identifies the individual personalities.

The DEFAULT SETTING: The factory setting. If adjustments are made, they must be returned to default setting.

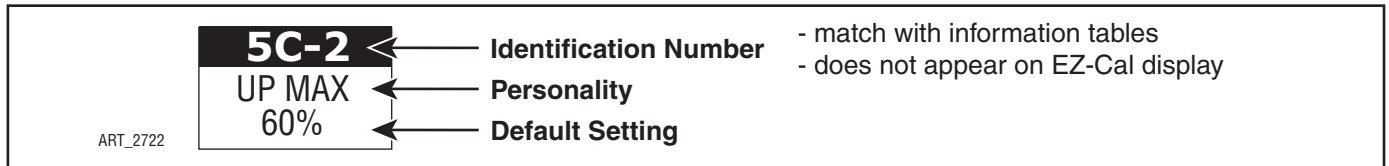

Changing Settings

It is necessary to enter Access Level 1 in order to change settings.

Error Messages

Refer to *HELP Menu* on page 4-21.

Scrolling Messages

The EZ-Cal will provide a scrolling message of the current error followed by a log of previous errors that may have occurred within recent operation. Refer to *Scrolling Message* on page 4-21.

Flash Codes

Flash Codes, provided from the GP400 red LED, will also assist in the event an EZ-cal is not available however; the EZ-cal yields considerably more relevant information. Refer to *EZ-Cal HELP MESSAGES* beginning on page 4-25 For flash codes.

Access Level 1

Access Level 1 is restricted. If Setup or Personality changes are necessary, contact the factory to obtain instructions and authorization to make changes to factory settings (publication number 91777).

Access Level 1 is required for Setup and Personality changes. Only qualified service personnel should be allowed to make adjustments in these areas.



PERSONALITIES ARE PRESET AT THE FACTORY TO PROVIDE PROPER MACHINE MOVEMENT AT SAFE SPEEDS. PERSONALITIES MUST NOT BE CHANGED WITHOUT PRIOR AUTHORIZATION FROM MEC AERIAL AND MAY ONLY BE RETURNED TO FACTORY SPECIFICATION.

Adjustments & Setup

GP400 MENU

EZ-Cal Flow Chart Chart 1 of 2

ANSI Models

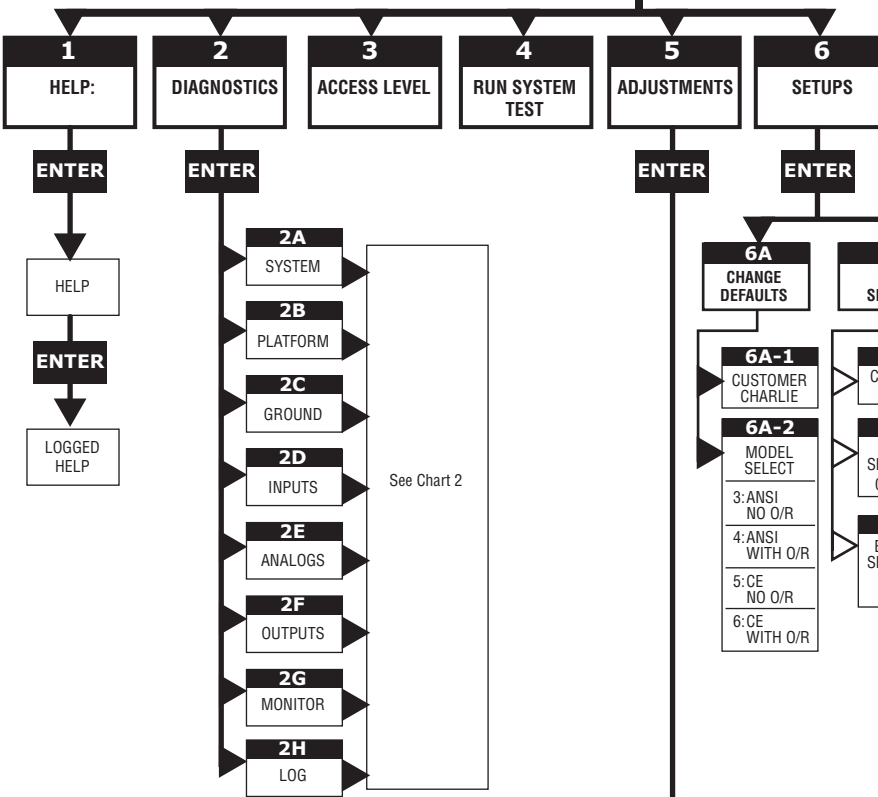

SYMBOL	KEY FUNCTIONS
	ESC/ENTER BUTTONS To move back and forth between menu and sub-menu
	LEFT/RIGHT BUTTONS Select menus and setting to be adjusted
	UP/DOWN BUTTONS Adjust setting values

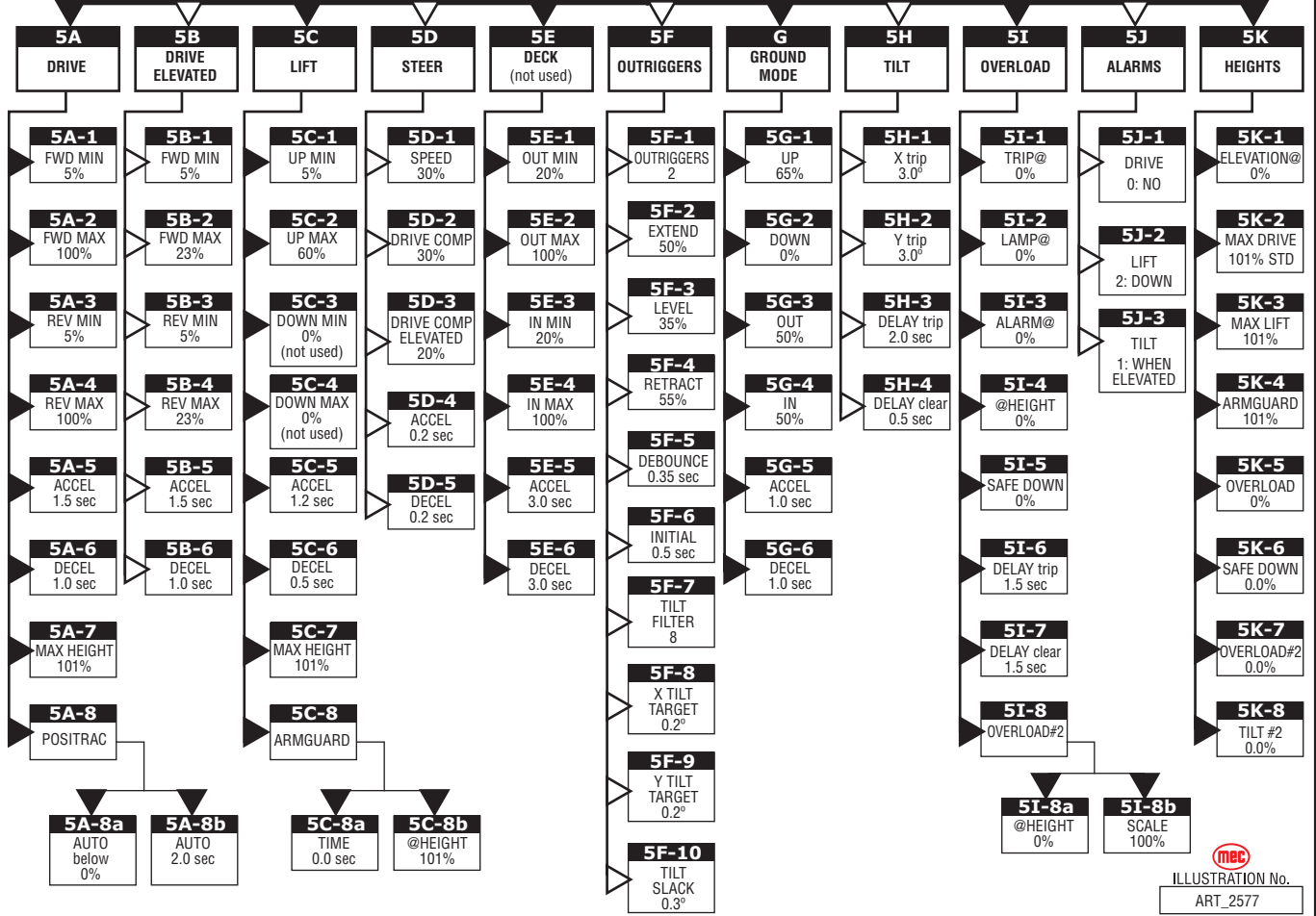

ILLUSTRATION No. ART_2577

DIAGNOSTIC

Use in conjunction with Diagnostic Tables for thorough explanation of readout and values.

GP400 MENU

2
DIAGNOSTICS

ENTER

EZ-Cal Flow Chart Chart 2 of 2

ANSI Models

SYMBOL	KEY FUNCTIONS
	ESC/ENTER BUTTONS To move back and forth between menu and sub-menu
	LEFT/RIGHT BUTTONS Select menus and setting to be adjusted
	UP/DOWN BUTTONS Adjust setting values

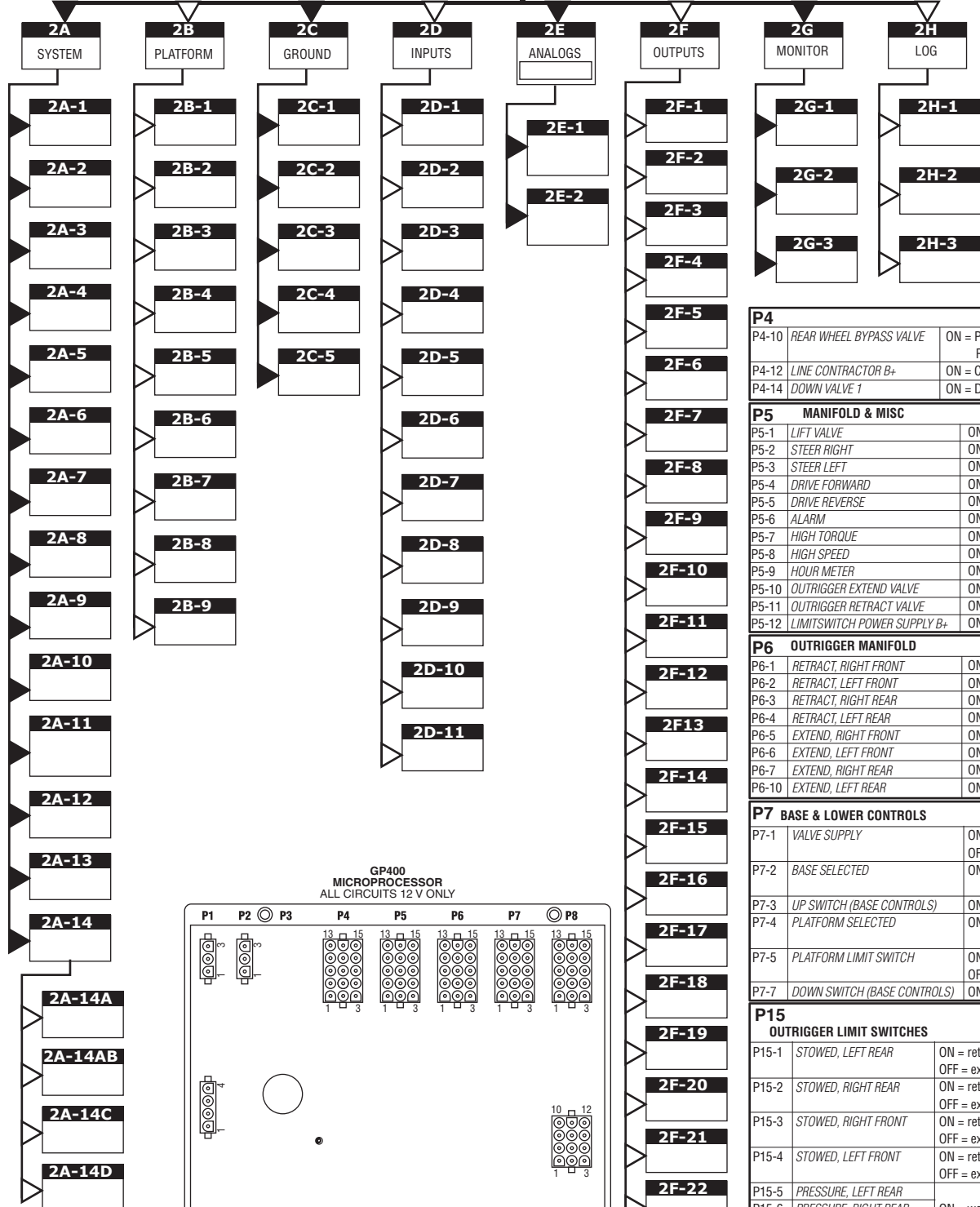

GP400 MICROPROCESSOR
ALL CIRCUITS 12 V ONLY

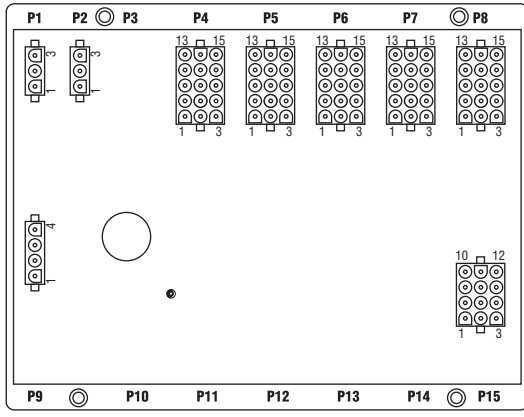

P4		
P4-10	REAR WHEEL BYPASS VALVE	ON = Powered - Rear Wheels in bypass
P4-12	LINE CONTRACTOR B+	ON = Contactor closed
P4-14	DOWN VALVE 1	ON = Down Valve activated

P5 MANIFOLD & MISC		
P5-1	LIFT VALVE	ON = Lift Valve activated
P5-2	STEER RIGHT	ON = Valve activated
P5-3	STEER LEFT	ON = Valve activated
P5-4	DRIVE FORWARD	ON = Valve activated
P5-5	DRIVE REVERSE	ON = Valve activated
P5-6	ALARM	ON = Alarm activated
P5-7	HIGH TORQUE	ON = Valve activated
P5-8	HIGH SPEED	ON = Valve activated
P5-9	HOUR METER	ON = Meter activated
P5-10	OUTRIGGER EXTEND VALVE	ON = Valve activated
P5-11	OUTRIGGER RETRACT VALVE	ON = Valve activated
P5-12	LIMITSWITCH POWER SUPPLY B+	ON = System powered-up

P6 OUTRIGGER MANIFOLD		
P6-1	RETRACT, RIGHT FRONT	ON = Valve activated
P6-2	RETRACT, LEFT FRONT	ON = Valve activated
P6-3	RETRACT, RIGHT REAR	ON = Valve activated
P6-4	RETRACT, LEFT REAR	ON = Valve activated
P6-5	EXTEND, RIGHT FRONT	ON = Valve activated
P6-6	EXTEND, LEFT FRONT	ON = Alarm activated
P6-7	EXTEND, RIGHT REAR	ON = Valve activated
P6-10	EXTEND, LEFT REAR	ON = Valve activated

P7 BASE & LOWER CONTROLS		
P7-1	VALVE SUPPLY	ON = Voltage, OFF = No Voltage
P7-2	BASE SELECTED	ON = Base Controls Operation
P7-3	UP SWITCH (BASE CONTROLS)	ON = Up activated
P7-4	PLATFORM SELECTED	ON = Platform Controls selected
P7-5	PLATFORM LIMIT SWITCH	ON = lowered, OFF = elevated
P7-7	DOWN SWITCH (BASE CONTROLS)	ON = Down activated

P15 OUTRIGGER LIMIT SWITCHES		
P15-1	STOWED, LEFT REAR	ON = retracted, OFF = extended past 1/2"
P15-2	STOWED, RIGHT REAR	ON = retracted, OFF = extended past 1/2"
P15-3	STOWED, RIGHT FRONT	ON = retracted, OFF = extended past 1/2"
P15-4	STOWED, LEFT FRONT	ON = retracted, OFF = extended past 1/2"
P15-5	PRESSURE, LEFT REAR	ON = weight on all 4 legs OFF = 1 or more legs up
P15-6	PRESSURE, RIGHT REAR	
P15-7	PRESSURE, RIGHT FRONT	
P15-8	PRESSURE, LEFT FRONT	
P15-10	PRESSURE, SWITCH SUPPLY	
P15-11	STOWED, SWITCH SUPPLY	

MEC ILLUSTRATION No. ART 2578



Adjustments & Setup

GP400 MENU

EZ-Cal Flow Chart

Chart 1 of 2

CE
Models

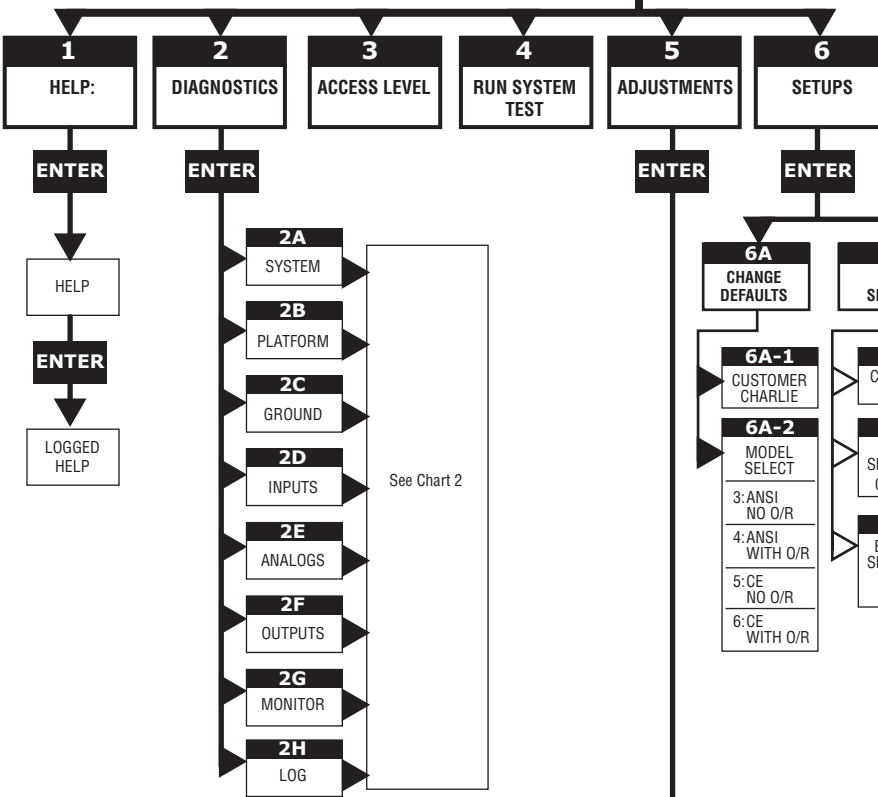

SYMBOL	KEY FUNCTIONS
	ESC/ENTER BUTTONS To move back and forth between menu and sub-menu
	LEFT/RIGHT BUTTONS Select menus and setting to be adjusted
	UP/DOWN BUTTONS Adjust setting values

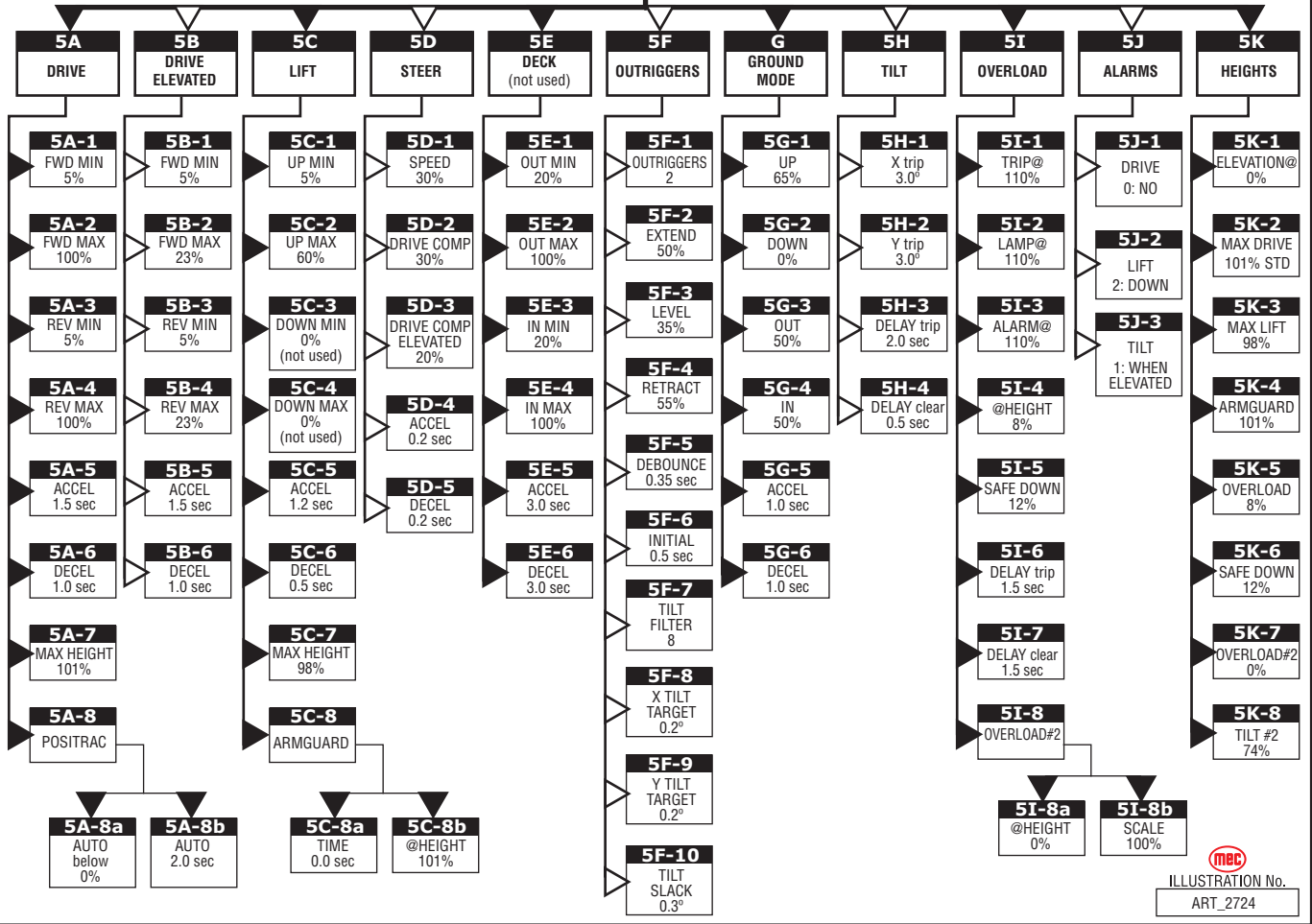

ILLUSTRATION No.
ART. 2724



DIAGNOSTIC

Use in conjunction with Diagnostic Tables for thorough explanation of readout and values.

GP400 MENU

2

DIAGNOSTICS

ENTER

EZ-Cal Flow Chart

Chart 2 of 2

CE
Models

SYMBOL	KEY FUNCTIONS
	ESC/ENTER BUTTONS To move back and forth between menu and sub-menu
	LEFT/RIGHT BUTTONS Select menus and setting to be adjusted
	UP/DOWN BUTTONS Adjust setting values

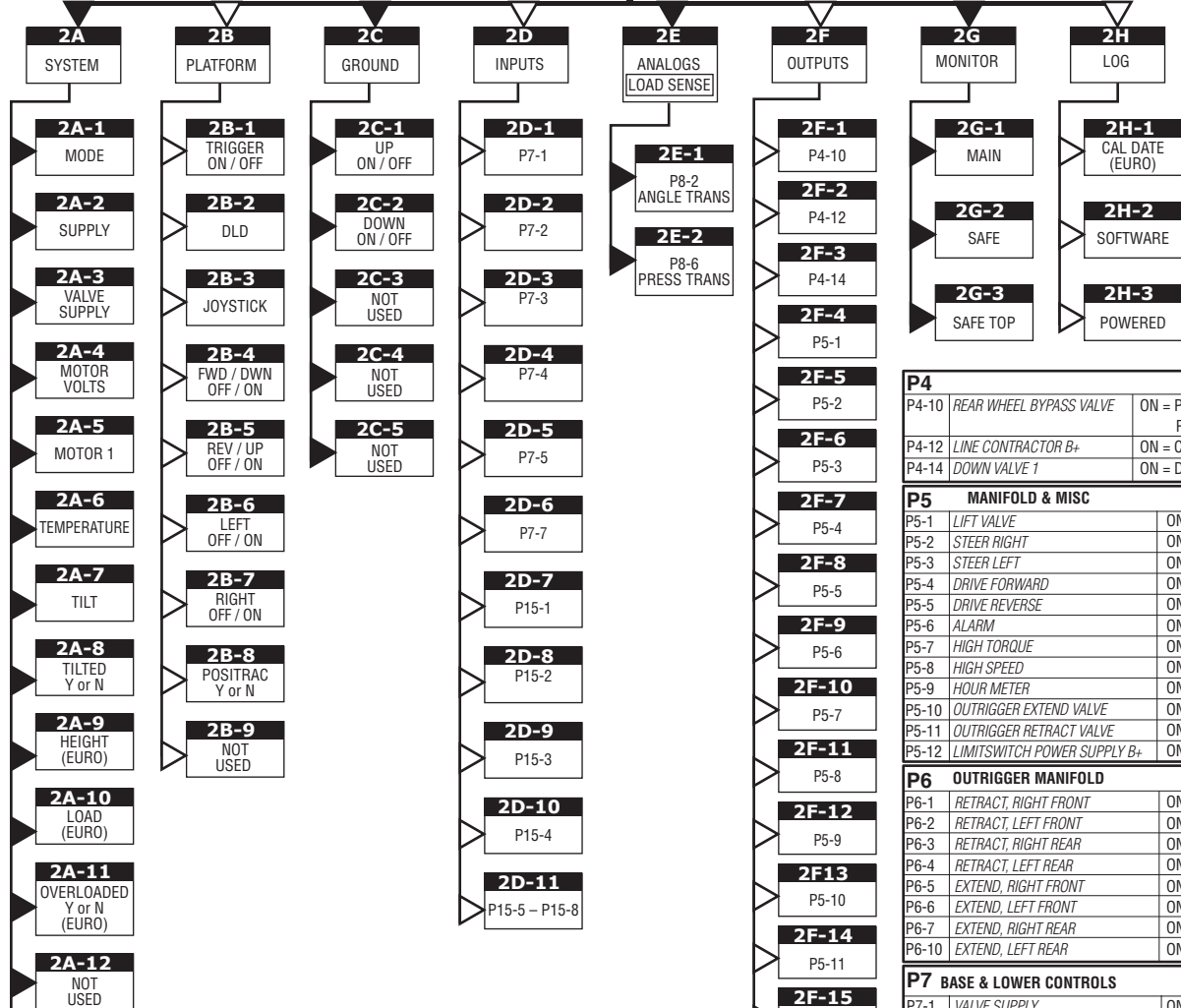

P4		
P4-10	REAR WHEEL BYPASS VALVE	ON = Powered - Rear Wheels in bypass
P4-12	LINE CONTRACTOR B+	ON = Contactor closed
P4-14	DOWN VALVE 1	ON = Down Valve activated

P5 MANIFOLD & MISC		
P5-1	LIFT VALVE	ON = Lift Valve activated
P5-2	STEER RIGHT	ON = Valve activated
P5-3	STEER LEFT	ON = Valve activated
P5-4	DRIVE FORWARD	ON = Valve activated
P5-5	DRIVE REVERSE	ON = Valve activated
P5-6	ALARM	ON = Alarm activated
P5-7	HIGH TORQUE	ON = Valve activated
P5-8	HIGH SPEED	ON = Valve activated
P5-9	HOUR METER	ON = Meter activated
P5-10	OUTRIGGER EXTEND VALVE	ON = Valve activated
P5-11	OUTRIGGER RETRACT VALVE	ON = Valve activated
P5-12	LIMITSWITCH POWER SUPPLY B+	ON = System powered-up

P6 OUTRIGGER MANIFOLD		
P6-1	RETRACT, RIGHT FRONT	ON = Valve activated
P6-2	RETRACT, LEFT FRONT	ON = Valve activated
P6-3	RETRACT, RIGHT REAR	ON = Valve activated
P6-4	RETRACT, LEFT REAR	ON = Valve activated
P6-5	EXTEND, RIGHT FRONT	ON = Valve activated
P6-6	EXTEND, LEFT FRONT	ON = Alarm activated
P6-7	EXTEND, RIGHT REAR	ON = Valve activated
P6-10	EXTEND, LEFT REAR	ON = Valve activated

P7 BASE & LOWER CONTROLS		
P7-1	VALVE SUPPLY	ON = Voltage, OFF = No Voltage
P7-2	BASE SELECTED	ON = Base Controls Operation
P7-3	UP SWITCH (BASE CONTROLS)	ON = Up activated
P7-4	PLATFORM SELECTED	ON = Platform Controls selected
P7-5	PLATFORM LIMIT SWITCH	ON = lowered, OFF = elevated
P7-7	DOWN SWITCH (BASE CONTROLS)	ON = Down activated

P15 OUTRIGGER LIMIT SWITCHES		
P15-1	STOWED, LEFT REAR	ON = retracted, OFF = extended past 1/2"
P15-2	STOWED, RIGHT REAR	ON = retracted, OFF = extended past 1/2"
P15-3	STOWED, RIGHT FRONT	ON = retracted, OFF = extended past 1/2"
P15-4	STOWED, LEFT FRONT	ON = retracted, OFF = extended past 1/2"
P15-5	PRESSURE, LEFT REAR	ON = weight on all 4 legs OFF = 1 or more legs up
P15-6	PRESSURE, RIGHT REAR	
P15-7	PRESSURE, RIGHT FRONT	
P15-8	PRESSURE, LEFT FRONT	
P15-10	PRESSURE, SWITCH SUPPLY	
P15-11	STOWED, SWITCH SUPPLY	

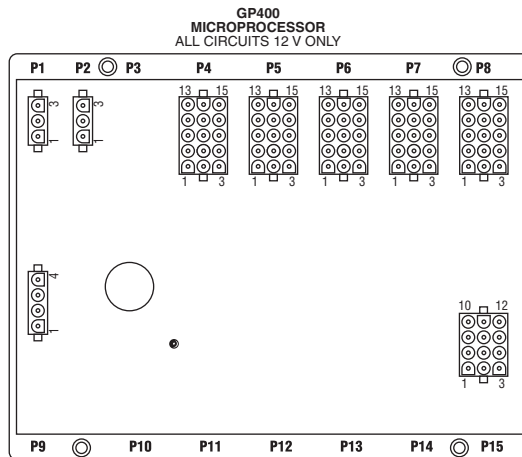

ILLUSTRATION No. ART 2725



EZ-CAL ADJUSTMENT

EZ-Cal Adjustment is only possible in Access Level 1.

Access Level 1 is restricted. Refer to *Access Level 1* on page 4-9.

EZ-Cal ADJUSTMENT Table

OPERATION	ID	PERSONALITY	FACTORY SETTING	EXPLANATION
5A DRIVE (PLATFORM STOWED)	5A-1	FWD Min	5 %	Slowest speed possible
	5A-2	FWD Max	100 %	Maximum speed potential
	5A-3	REV Min	5 %	Slowest speed possible
	5A-4	REV Max	100 %	Maximum speed potential
	5A-5	ACCEL	1.5 sec	Ramp up time to maximum
	5A-6	DECEL	1.0 sec	Ramp down to stop
	5A-7	MAX Height	101 %	Maximum Drivable Height
	5A-8	Positrack	Not Used	Not Used
Sub Menu	5A-8a	AUTO below	0%	Not Used
	5A-8b	AUTO	2.0 sec	Not Used
5B DRIVE - ELEVATED	5B-1	FWD Min	5 %	Slowest speed possible
	5B-2	FWD Max	23 %	Maximum speed potential
	5B-3	REV Min	5 %	Slowest speed possible
	5B-4	REV Max	23 %	Maximum speed potential
	5B-5	ACCEL	1.5 sec	Ramp up time to maximum
	5B-6	DECEL	1.0 sec	Ramp down to stop
5C LIFT	5C-1	UP Min	5 %	Slowest speed possible
	5C-2	UP Max	60 %	Maximum speed potential
	5C-3	DOWN Min	0 % (not used)	Gravity down (not used)
	5C-4	DOWN Max	0 % (not used)	Gravity down (not used)
	5C-5	ACCEL	1.2 sec	Ramp up time to maximum
	5C-6	DECEL	0.5 sec	Ramp down to stop
	5C-7	Max Height	ANSI: 101 % CE: 98%	Maximum height potential
	5C-8	Armguard	—	CE Option Only
Sub Menu	5C-8a	Time	0.0 sec	CE Option Only
	5C-8b	@ Height	101 %	CE Option Only
5D STEER	5D-1	Speed	30 %	Maximum speed potential
	5D-2	Drive Compensation	30 %	Adds additional to drive speed
	5D-3	Drive Comp Elevated	20 %	Adds additional to drive speed elevated
	5D-4	Accel	0.2 sec	Ramp up time to maximum
	5D-5	Decel	0.2 sec	Ramp down to stop
5E DECK	5E-	Not Used	Not Used	Power-out deck (not used)

continued...

EZ-Cal ADJUSTMENT Table *continued*

OPERATION	I D	PERSONALITY	FACTORY SETTING	EXPLANATION
5F OUTRIGGERS	5F-1	Outriggers 1=N 2=Y	2	Prevents drive when outrigger legs are down
	5F-2	Outrigger Test	Y / N	Test feature (see outrigger section)
	5F-3	Extend	45 %	Maximum speed potential
	5F-4	Level	35 %	Extend speed after pads touch down
	5F-5	Retract	55 %	Maximum speed potential
	5F-6	Debounce	0.35 sec	Compensates for switch bounce
	5F-7	Initial	0.5 sec	Push outrigger legs when deployed / operated
	5F-8	Tilt Filter	8	Compensates for tilt sensor free movement
	5F-9	X Tilt Target	2 Degrees	Target level stops movement
	5F-10	Y Tilt Target	2 Degrees	Target level stops movement
	5F-11	Tilt Slack	3 Degrees	Variance to tilt target
5G GROUND MODE Lower Control Operations	5G-1	UP	75%	Maximum speed potential
	5G-2	DOWN	0 %	Gravity Down
	5G-3	OUT	0 %	Power deck operation (not used)
	5G-4	IN	0 %	Power deck operation (not used)
	5G-5	Accel	1.0 sec	Ramp up time to maximum
	5G-6	Decel	1.0 sec	Ramp down to stop
5H TILT	5H-1	X Trip	3.0 degrees	Angle tilt sensor signals out of level
	5H-2	Y Trip	3.0 degrees	Angle tilt sensor signals out of level
	5H-3	Delay Trip	2.0 sec	Time delay between tip and signal
	5H-4	Delay Clear	0.5 sec	Time delay between clear tip and signal off
5I OVERLOAD CE: values apply ANSI: values = 0	5I-1	Trip @	ANSI: 0% CE: 110%	% of weight over maximum to trigger overload
	5I-2	Lamp @	ANSI: 0% CE: 0%	% of weight over maximum to trigger lamp
	5I-3	Alarm @	ANSI: 0% CE: 0%	% of weight over maximum to trigger alarm
	5I-4	@ Height	ANSI: 0% CE: 8%	% of elevation load sense starts monitoring weight
	5I-5	Safe Down	ANSI: 0% CE: 12%	% of elevation lift down still operates in overload
	5I-6	Delay Trip	1.5 sec	Delay before overload trip
	5I-7	Delay Clear	1.5 sec	Delay before overload clear
	5I-8	Overload #2	—	Sub category, press ENTER to access
Sub Menu	5I-8a	@ Height	0%	% of height for secondary overload valve
	5I-8b	Scale	100%	% of reduced overload valve
5J ALARMS	5J-1	Drive Yes/No	No	1 = FWD 2 = REV 3 = Both 4 = All Motion
	5J-2	Lift	2 = Down	1 = Up 2 = Down 3 = Both 4 = All Motion
	5J-3	Tilt	1 = When Elevated	1 = When Elevated 2 = Always
5K Heights	5K-1	Elevation @	0%	
	5K-2	Maximum Drive	101%	Maximum driveable height
	5K-3	Maximum Lift	ANSI: 101% CE: 98%	Maximum elevated height potential
	5K-4	Armguard	101%	Stops descent for 5 sec
	5K-5	Overload	ANSI: 0% CE: 8%	% of elevation load sense starts monitoring weight
	5K-6	Safe Down	ANSI: 0% CE: 12%	% of elevation lift down still operates in overload
	5K-7	Overload #2	0%	Not Used
	5K-8	Tilt #2	ANSI: 0% CE: 74%	Reduced degree of tilt at % elevation

EZ-CAL SETUP

EZ-Cal Setup is only possible in Access Level 1 or Access Level 2.

Access Level 1 and Access Level 2 are restricted. Refer to *Access Level 1* on page 4-9.

EZ-Cal SETUP Table

OPERATION	ID	FUNCTION	FACTORY SETTING	EXPLANATION
6A CHANGE DEFAULTS	6A-1	Customer	Charlie	Identifies MEC Aerial brand
	6A-2	Model Select	3 = ANSI, No Outriggers 4 = ANSI, With Outriggers 5 = CE, No Outriggers 6 = CE, With Outriggers	Identifies model of machine
6B TILT SETUPS	6B-1	Calibrate Level? Y=ENTER – N=ESC Pressing ENTER twice will calibrate level sensor Ensure machine is on flat level surface before calibrating level sensor		
	6B-2	Tilt Shutdown	2 = Lift	Function shut down tilted when platform stowed
	6B-3	Elevated Tilt Shutdown	1 = Lift & Drive	Function shut down tilted when platform elevated
	6C-1	Elevation @	0 %	CE Option only
6C HEIGHT SETUP (CE OPTION ONLY)	6C-2	Calibrate Height	CE procedure	for calibration of CE Load Sense system
	6C-3	Minimum Lift	1.0 sec	CE Option Only
	6C-4	Samples	0.10 sec	CE Option Only
	6C-5	Tilt Correction	Disabled	CE Option Only
	6C-6	Slow Down	10 %	CE Option Only
	6D LOAD SETUPS (CE OPTION ONLY)	6D-1	Calibrate Load	CE procedure
6D-2		Faulty Load	100 %	CE Option Only
6D-3		Dynamic Scale	95 %	CE Option Only
6E INTERLOCKS	6E-1	Trigger Only	10.0 sec	Delay enable pulled before timeout
	6E-2	Trigger Wait	0.0 sec	Delay before function after enable pulled
	6E-3	Function Hold	0.2 sec	Time function holds after enable released

EZ-CAL DIAGNOSTICS

The EZ-Cal Diagnostics menu provides the ability to view and test individual circuits for irregularities. Whether diagnosing a failure or testing functions during preventative maintenance, the *Diagnostics Menu* provides a quick view at the inputs and outputs as registered by the GP400 Control Module and the P600 Motor Control Module **in real time**. Using the EZ-Cal Flow Chart, compare ID number to this menu for circuit identification and result.

To reach DIAGNOSTICS menu from HELP;

- Press the right arrow and scroll to DIAGNOSTICS and press ENTER.
- Locate the desired sub menu and press ENTER.
- Press the right arrow to scroll through the test points.

NOTE: The ID number will not appear on the EZ-Cal display. It is shown in the *Diagnostics Menu* for reference only.

- Press **ESC** to go back one level (necessary to change selection).

EZ-Cal DIAGNOSTICS Menu

SELECTION	ID	READOUT	EXPLANATION
2A SYSTEM	2A-1	MODE	Current function message/s, press ENTER for additional information
	2A-2	Supply	Indicates valve supply output on or off, should be ON
	2A-3	Valve Supply	Regulated 12 volt signal output from Motor Controller to supply all 12 volt circuits
	2A-4	Motor Volts	Real time motor voltage
	2A-5	Motor 1	Real time motor amperage draw. Varies depending on load and motor speed
	2A-6	Temperature	Motor controller chassis temp. Error message "too Hot" at 75 C.
	2A-7	Tilt	Current state of tilt as measured by internal tilt sensor in degrees
	2A-8	Tilted Y/N	Indicates tilted state. All motorized functions stop above limit
	2A-9	Height	Current state of platform elevation in %. (Over load option only)
	2A-10	Load	Current load on platform in %. (Over load option only)
	2A-11	Overloaded Y/N	Platform overloaded. (Over load option only)
	2A-12	Last Moved	Not used
	2A-13	Elevated Y/N	Shows platform elevation above/below limit switch
	2A-14	Outrigger	See 2A14 Outrigger sub categories below for outrigger diagnostics
SUB CATAGORIES	2A-14a	O/R Retracted Y/N	Status of outrigger retract and mechanical switch operation
	2A-14b	O/R Extended Y/N	Status of outrigger extend and pressure switch operation
	2A-14c	O/R Status	current o/r status will be displayed
	2A-14d	O/R Test Y/N	Follow EZ-Cal instruction sequence for outrigger valve and switches test (next page)

continued ...

EZ-CAL OUTRIGGER TEST MODE

The GP400 provides a program that will allow the technician to test the individual components within each outrigger leg, one leg at a time.

1. Plug in the EZ-cal tool and go to **DIAGNOSTICS / SYSTEM / OUTRIGGERS / O/R TEST - NO.**
2. Press the up arrow and ENTER and the display will read **2 =EXTEND FL.**
3. Operate the outrigger switch in upper control box.
 - Only the front left outrigger leg will extend.
 - Once the leg touches down the function should automatically stop extending. *The extending leg indicates an operational extend valve in that leg.*
 - The automatic stop indicates an operational pressureswitch. *If the pressure switch was not functional the outrigger leg would continue to extend and lift the machine until it reached the end of its stroke.*
 - After the leg automatically stops the EZ-cal display will momentarily read **3=FL EXTENDED.** The display will then change to **4=RETRACT FL.**
4. Operate the outrigger switch to retract outriggers.
 - The front left outrigger leg should fully retract and stop. *The retracting leg indicates an operational retract valve in that leg.*
 - If the mechanical switch in that leg is not operational the EZ-cal will display **CHECK SWITCHES.**
5. Continue on the sequence through the other three outrigger legs. If all legs extend and retract properly through the sequence the display will read **EVERYTHING OK.**

EZ-Cal **DIAGNOSTICS** Menu *continued*

SELECTION	ID	READOUT	EXPLANATION
2B PLATFORM	2B-1	Trigger ON/OFF	Current status of enable trigger - platform controller
	2B-2	DLD	Status of Lift/Drive selector switch
	2B-3	Joystick	Indicates % of stroke from center in real time. Direction not indicated here.
	2B-4	FWD/DOWN OFF/ON	Status of Forward micro-switch Forward stroke of the joystick
	2B-5	REV/UP OFF/ON	Status of Reverse micro-switch Reverse stroke of the joystick
	2B-6	LEFT OFF/ON	Status of Left Steer switch
	2B-7	RIGHT OFF/ON	Status of Right Steer switch
	2B-8	Posi-track Y/N	Status of rear wheel solenoids activation. Activated in high speed or elevated drive
	2B-9	EMSp OFF/ON	Not used
2C GROUND	2C-1	UP OFF/ON	Status of Up switch from lower control station
	2C-2	DOWN OFF/ON	Status of Down switch from lower control station
	2C-3	OUT OFF/ON	Not used
	2C-4	IN OFF/ON	Not used
	2C-5	EMSp OFF/ON	Not used
2D INPUTS	2D-1	P7-1	12V supply from Motor Controller. ON= Voltage, OFF= no voltage
	2D-2	P7-2	Base selected, ON= selector on Base position - unit operating from base controls
	2D-3	P7-3	Up selected from base controls, ON= Up activated
	2D-4	P7-4	Platform Selected. ON= selector in platform position. Operate from platform controls
	2D-5	P7-5	Platform Down limit switch. ON= platform down, OFF= platform elevated
	2D-6	P7-7	Down selected from base controls, ON= Down activated
		P7-6 & P7-8 – P7-15	Not used
	2D-7	P15-1	Outrigger retracted L/R. ON= retracted, OFF= extended beyond 1/2"
	2D-8	P15-2	Outrigger retracted R/R. ON= retracted, OFF= extended beyond 1/2"
	2D-9	P15-3	Outrigger retracted R/F. ON= retracted, OFF= extended beyond 1/2"
	2D-10	P15-4	Outrigger retracted L/F. ON= retracted, OFF= extended beyond 1/2"
2D-11	P15-5 – P15-8	O/R pressure switches. ON= weight on all 4 outrigger legs, OFF= one or more legs up	
	P15-9	Not used	
2E ANALOGS	2E-1	P8-2	Current state of angle transducer (overload option only)
	2E-2	P8-6	Current state of pressure transducer (overload option only)

continued...

EZ-Cal *DIAGNOSTICS* Menu *continued*

SELECTION	ID	READOUT	EXPLANATION
2F OUTPUTS READOUT = Plug# and Pin# example: P7-1 = Plug 7-Pin1 refer to schematic		Numbers not listed but displayed by EZ-Cal <i>are not used.</i>	
	2F-1	P4-10	Rear wheel bypass valves. ON= valves powered - rear wheels in bypass
	2F-2	P4-12	Line Contactor signal B+. ON= Contactor closed
	2F-3	P4-14	Down Valve/s signal B+. ON= down valve activated
	2F-4	P5-1	Lift Valve Signal B+. ON= lift valve activated
	2F-5	P5-2	Steer right signal B+. ON= valve activated
	2F-6	P5-3	Steer Left signal B+. ON= valve activated
	2F-7	P5-4	Drive FWD signal B+. ON= valve activated
	2F-8	P5-5	Drive Rev signal B+. ON= valve activated
	2F-9	P5-6	Alarm signal B+. ON= alarm activated
	2F-10	P5-7	High Torque signal B+. ON= valve activated
	2F-11	P5-8	High Speed signal B+. ON= valve activated
	2F-12	P5-9	Hour Meter signal B+. ON= Meter activated
	2F-13	P5-10	Outrigger Extend signal B+. ON= valve activated (sends oil to O/R legs)
	2F-14	P5-11	Outrigger Retract signal B+. ON= valve activated (sends oil to O/R legs)
	2F-15	P5-12	Power supply to Limit Switch. Should be ON when system is powered up
	2F-16	P6-1	Retract R/F outrigger. ON= valve activated.
	2F-17	P6-2	Retract L/F outrigger. ON= valve activated.
	2F-18	P6-3	Retract R/R outrigger. ON= valve activated.
	2F-19	P6-4	Retract L/R outrigger. ON= valve activated.
	2F-20	P6-5	Extend R/F outrigger. ON= valve activated
	2F-21	P6-6	Extend L/F outrigger. ON= valve activated
	2F-22	P6-7	Extend R/R outrigger. ON= valve activated
	2F-23	P6-10	Extend L/R outrigger. ON= valve activated
2G MONITOR	2G-1	MAIN	Refers to valve output,
	2G-2	SAFE	Refers to P4-12 – P4-15 outputs
	2G-3	SAFE TOP	embedded circuit protection, failure here = internal failure
2H LOG	2H-1	Cal Date	Date of Load Sense calibration (Euro option only)
	2H-2	Software	Should read 'V22.3' This is MEC specific software.
	2H-3	Powered	Accumulated time GP400 powered up (red LED on)

RETRIEVE MODE AND HELP MESSAGES FROM THE EZ-CAL

Note: *It is important to understand that an error message will only be available if the red Diagnostic LED is flashing. If the machine is not operating properly and the red Diagnostic LED is not flashing, the trouble may lie with something not monitored by the electronic control system, i.e. a switch, hydraulic valve or wiring damage.*

There are two different menus that you can access for message retrieval; MODE and HELP.

MODE Menu

Allows the technician to see the current state of the controller with a short description. Go to, DIAGNOSTICS/SYSTEM/MODE (EZ-Cal Flow Chart 2, ID# 2a1). Pressing ENTER a second time will provide additional information with certain messages.

HELP Menu

Provides various HELP messages to identify failure modes.

Some error messages may also be identified by counting the number of times the red LED flashes on the controller so that even without access to an EZ-Cal, some simple diagnostics are possible. However, it is recommended to use an EZ-Cal to diagnose problems, and not rely on the LED! The EZ-Cal provides a much higher detail of information.

MODE Message

- Connect the EZ-Cal (see illustration).
The display will read, "HELP: PRESS ENTER".
- Press Enter to display the current message.
- Refer to the following list of HELP messages to better understand the nature of the message or fault.
- If the GP400 does not register a fault, the display will read EVERYTHING OK.

Scrolling Message

Pressing **ENTER** twice will provide a scrolling message of the current message (if one exists) followed by a log of previous operations and/or errors that occurred immediately prior, starting with most recent. **All messages are cleared whenever the system is powered down.**

Other helpful menus available include **DIAGNOSTICS** which allows the technician to monitor specific plug input/output information. Refer to EZ-Cal Flow Chart 2 – Diagnostics (ANSI page 4-11 – CE page 4-13).

MODE Messages

The purpose of **MODE** is to indicate, in real time, the current state of the controller with a short description.

INITIALIZING

- The system is preparing to operate, immediately after power-on.

SHUTDOWN!

- The system cannot operate – for example both the PLATFORM & GROUND inputs are active together.

CHECK CAN bus

- The system cannot operate – CAN bus communications is not successful (for example wire damage to the platform)

PLATFORM, GROUND

- The system is ready to operate, from the platform or ground controls as indicated (selected by the Base/ Platform selector switch)

GROUND UP, GROUND DOWN,

- A ground function is operating normally

GROUND UP LOCKED, GROUND DOWN LOCKED,

- A ground function is selected but not allowed (for example, the function switch was closed at power-on)

GROUND FAULTY

- Multiple ground function inputs are active at the same time

WAITING FOR TRIGGER

- A platform function is selected, but the joystick trigger switch is not closed (close the trigger switch to proceed)

TRIGGER CLOSED

- The joystick trigger switch is closed, but no function is selected (select a function to proceed)

TRIGGER LOCKED

- The joystick trigger switch was closed at power-on, or closed for too long with no function selected (check trigger switch)

FORWARD, REVERSE

- A platform drive function is operating normally

FORWARD (LEFT), FORWARD (RIGHT), REVERSE (LEFT), REVERSE (RIGHT)

- A platform drive function is operating normally, with steer also active

STEER LEFT, STEER RIGHT

- A platform steer function is operating normally (without drive)

UP, DOWN

- A platform lift/lower function is operating normally

FORWARD LOCKED, REVERSE LOCKED

- A platform drive function is selected but not allowed (for example, the switch was closed at power-on)

LEFT LOCKED, RIGHT LOCKED

- A platform steer function is selected but not allowed (for example, the switch was closed at power-on)

UP LOCKED, DOWN LOCKED

- A platform lift/lower function is selected but not allowed (for example, the switch was closed at power-on)

CHECK DRIVE/LIFT

- Neither platform drive nor platform lift select is active, or both are active at the same time

CHECK JOYSTICK

- Both platform joystick directions are active at the same time

STEER FAULTY

- Both platform steer directions are active at the same time

EXTENDING LEGS

- Outrigger legs are extending normally

RETRACTING LEGS

- Outrigger legs are extending normally

OUTRIGGERS LOCKED

- An outrigger function is selected but not allowed (for example, the switch was closed at power-ON)

INTERLOCKED**

- An interlock shutdown is active, preventing one or more functions. The interlock can be due to many different causes ...

Press <ENTER> from the **MODE display to see the precise cause of the interlock (listed below) – press <ESC> from that display to return to the **MODE** display:

TEST MODE

- The system test mode is active – switch power off and on again to clear

TILTED

- The vehicle is tilted beyond limits, descend, then move vehicle to a more level location

OVERLOADED

- The vehicle platform is overloaded, reduce platform load.
(CE option only)

TOO HIGH

- The vehicle platform is too high to allow some functions – descend first

ARMGUARD

- During descent, the system is configured to stop movement to provide an armguard delay – release and re-select DOWN to continue lowering (CE option only)

TOO HOT

- The EZLIFT heatsink has reached 75°C, preventing all functions except lowering. Functions will be allowed again when the heatsink cools to below 70°C.
- The heatsink temperature can be viewed in the DIAGNOSTICS/SYSTEM/ TEMPERATURE display, ID # 2a5.
- The heatsink must be bolted to a significant metal panel of the vehicle, capable of dissipating heat to the environment.

UNCALIBRATED

- The height and/or pressure sensors have not been calibrated see CALIBRATION OF OVERLOAD SYSTEM (CE option only).
- If machine is not equipped with Overload system, refer to SETUPS table and change those personalities that do not match the figure listed in the table.

EXTERNAL ALL, EXTERNAL DRIVE, EXTERNAL LIFT

- An external cutout input is preventing functions – determine the cause of the external cutout (for example, a limit switch)

OUTRIGGERS

- Drive is prevented if the outriggers are not all retracted. Green LED, located on upper control box, will illuminate when outriggers are retracted.

EZ-CAL HELP MESSAGES

In addition to the **MODE** messages detailed above, the GP400 provides a **HELP** message to identify failure modes. Some error messages may also be identified by counting the number of times the red LED flashes on the controller so that even without access to an EZ-Cal, some simple diagnostics are possible. However, it is recommended to use an EZ-Cal to diagnose problems, and not rely on the LED! The EZ-Cal provides a much higher detail of information.

- Connect the EZ-Cal (see illustration).
The display will read, "HELP: PRESS ENTER".
- Press Enter to display the current message.
- Refer to the following list of HELP messages to better understand the nature of the message or fault.
- If the GP400 does not register a fault, the display will read EVERYTHING OK.

Pressing ENTER twice will provide a scrolling message of the current message (if one exists) followed by a log of previous operations and/or errors that occurred immediately prior, starting with most recent. **All messages are cleared whenever the system is powered down.**

NOTE: When using the LED to attempt diagnosis, please note that a **DUAL FLASH** code is indicated. The LED will flash on/off a certain number of times, pause off for a short delay, then flash on/off a second certain number of times, followed by a much longer pause off. The sequence will then repeat.

INFORMATION ONLY Messages

The following are "information only" HELP messages which are not indicative of any possible problem – there is no LED flash code (the LED remains on steady):

STARTUP! (no flash code)

- The system has just been powered on and is carrying out some initialization steps prior to being ready to operate. If you select a function during this time, it may be locked out until you release then re-select it.

EVERYTHING OK (no flash code)

- There is no problem with the system – it is ready to operate in platform mode when a function is selected.

NOTE: *If this is the **HELP** message when a function is selected, check for open-circuit switches or wiring.*

GROUND MODE ACTIVE! (no flash code)

- There is no problem with the GP400 – it is ready to operate in ground mode when a function is selected.

CLOSE TRIGGER (no flash code)

- A platform function is selected but the trigger switch is not closed.

VEHICLE TILTED (no flash code)

- The vehicle is tilted beyond the limits, some functions may be prevented.

FUNCTION ACTIVE Messages

The following **HELP** messages indicate that there is no problem with the GP400 but that a function is active – the vehicle should be moving as requested by the operator.

DRIVING! (no flash code)

LIFTING! (no flash code)

LOWERING! (no flash code)

STEERING! (no flash code)

EXTENDING OUTRIGGERS! (no flash code)

RETRACTING OUTRIGGERS! (no flash code)

CALIBRATION Messages

The following are “calibration” **HELP** messages – until the machine is properly calibrated for height and/or pressure (as required), many functions will not be available.

NOT CALIBRATED ----- Flash Code: 1/1

FUNCTIONS LOCKED - NOT CALIBRATED ----- Flash Code: 1/1

- The height and/or pressure sensors have not been calibrated and are required because of the setup of the GP400.
- If overload functions are active (**ADJUSTMENTS/OVERLOAD TRIP@**, **LAMP@** or **ALARM@** set to a non-zero value) then both the height and pressure sensors must be calibrated.
- If overload functions are not active, but height-based decisions are active (**ADJUSTMENTS/HEIGHT** values set to between 1% and 100%) then the height sensors must be calibrated.
- Calibration procedures are accessible from the **SETUPS/HEIGHT SETUPS** and **SETUPS/LOAD SETUPS** menus.

FAULT: CUSTOMER ----- Flash Code: 1/1

- The system must be configured to the customer requirements – with the EZ-Cal in **SETUPS/CHANGE DEFAULTS** menu, select Charlie.

SHUTDOWN Help Messages

This section lists “shutdown” **HELP** messages – functions can be shut down to prevent them being used:

SHUTDOWN - CHECK EMS SWITCHES! ----- Flash Code: 2/1

- The Base/Platform selector switch position indicates the mode in which the system must operate if both are active together; the system does not know how to function

FUNCTIONS LOCKED - TEST MODE SELECTED ----- Flash Code: 2/2

- Test mode is not accessible with this system. Switch power off/on to reset to normal operation

FUNCTIONS LOCKED - ARMGUARD (CE option only) ----- Flash Code: 2/2

- During descent, the System can stop movement for a configurable time, to allow a safety check that no-one is close to the machine. The operator must release and re-select **DOWN** to continue lowering (after the delay timeout).
- If the armguard feature is not wanted, set **ADJUSTMENTS/LIFT/ ARMGUARD/TIME** to 0.0s.

FUNCTIONS LOCKED – OVERLOADED (CE option only) ----- Flash Code: 2/2

- System overload features are active, and the platform is excessively loaded to allow operation – the platform load must be reduced.
- If the overload features are not wanted, be sure to set ADJUSTMENTS/ OVERLOAD TRIP@, LAMP@ or ALARM@ to 0%.

FUNCTIONS LOCKED – UNDERLOADED (CE option only) ----- Flash Code: 2/2

- System overload features are active, and the platform load is too low to be valid – this could be caused by erroneous calibration, a sensor fault, or a change in the vehicle mechanics/hydraulics.
- If the under-load feature is not wanted, be sure to set SETUPS/LOAD SETUPS/ FAULTY LOAD to -100%.

FUNCTIONS LOCKED - TOO HIGH ----- Flash Code: 2/2

- The platform is raised to high to allow some functions.
- Check ADJUSTMENTS/HEIGHTS/MAX DRIVE and MAX LIFT; if drive and/or lift is allowed at all heights, set to 101% to disable the MAX HEIGHT function.

FUNCTIONS LOCKED - TILTED ----- Flash Code: 2/2

- The vehicle is tilted too much to allow some functions.
- Check ADJUSTMENTS/TILT/Xtrip and Ytrip, which determine the maximum allowed vehicle tilt. See chart 5 – EZ-Cal Adjustments for factory default values.
- Also check SETUPS/TILT SETUPS/TILT SHUTDOWN and ELEV.TILT SHUTDOWN which determine what functions to prevent when the vehicle is tilted. See chart 6 – EZ-Cal Setups for factory default values.

FUNCTIONS LOCKED - EXTERNAL SHUTDOWN ----- Flash Code: 2/2

- An external shutdown is preventing functions – check DIAGNOSTICS/SYSTEM/ MODE/INTERLOCK to see which external interlock is active.

CHECK GROUND INPUT SWITCHES! ----- Flash Code: 2/2

- There is a problem with the ground function select switches – more than one is active at the same time.

SELECT DRIVE/LIFT MODE! ----- Flash Code: 2/2

- There is a problem with the platform drive/lift select switch – neither mode is selected.

CHECK DRIVE/LIFT SELECT SWITCH! ----- Flash Code: 2/2

- There is a problem with the platform drive/lift select switch – both modes are selected together.

CHECK JOYSTICK SWITCHES! ----- Flash Code: 2/2

- There is a problem with the platform joystick switches – both directions are selected together.

RELEASE TRIGGER! ----- Flash Code: 2/2

- The trigger was closed at power-on, or closed for too long with no function selected .

RELEASE GROUND SWITCHES! ----- Flash Code: 2/2

- Ground function switches were closed at power-on.

RELEASE JOYSTICK SWITCHES! ----- Flash Code: 2/2

- Platform joystick switches were closed at power-on, or closed for too long without trigger switch (see **SETUPS/INTERLOCKS/TRIGGERwait**).

RELEASE OUTRIGGER SWITCHES! ----- Flash Code: 2/2

- Outrigger switches were closed at power-on.

WIRING Messages

The following are “wiring” HELP messages – problems have been detected which are likely due to vehicle wiring issues:

FAULT: ENERGIZED VALVE - CHECK P5 WIRING! ----- Flash Code: 3/2

FAULT: VALVE FEEDBACK HIGH - CHECK VALVE WIRING! ----- Flash Code: 3/2

- There is a voltage on one or more valve outputs, when all outputs are off.
- Check each valve output to trace where the invalid supply is coming from.

FAULT: CAPBANK VOLTAGE TOO HIGH - CHECK LINE CONT! ----- Flash Code: 3/3

- The voltage on the B+ stud of the controller (connected to an internal voltage stabilization capacitor bank) is too high when the line contactor is off. B+ stud voltage should be approximately 32 volts at idle.
- Check the line contactor tips are not welded, and check the power wiring for errors .

FAULT: ENERGIZED LINE CONTACTOR - CHECK P5 WIRING! ----- Flash Code: 3/4

- There is a voltage on the line contactor coil output, when it is off.
- Check wiring to the line contactor coil to trace where the invalid supply is coming from.

FAULT: MOTOR OVERLOAD! ----- Flash Code: 3/5

- The power protection circuits in the controller have activated to protect from extreme overload.
- Check for short-circuit power wiring; check for a seized or shorted motor.

P600 TEMPERATURE Messages

- This section lists “temperature” HELP messages – problems have been detected which are likely due to excessive dutycycling or poor heatsinking:

FAULT: BAD INTERNAL TEMPERATURE SENSOR! ----- Flash Code: 4/1

- The heatsink temperature is out of range; if the fault remains, the power controller may have to be replaced.

FUNCTIONS LOCKED - TOO HOT! ----- Flash Code: 4/2

- The heatsink temperature exceeds 75°C, preventing all functions except lowering. Check for excessive motor current draw; check for good heatsinking to vehicle chassis.

SUPPLY Messages

The following are “supply” HELP messages – problems have been detected which are likely due to supply issues:

FAULT: BAD INTERNAL 5V! ----- Flash Code: 4/2

- The internal “5V slave” supply is out of range; if the fault remains, the controller may have to be replaced.

FAULT: BAD INTERNAL SLAVE! ----- Flash Code: 4/2

- The internal “slave” is not operating correctly; if the fault remains, the controller may have to be replaced.

FAULT: BAD INTERNAL 12V! ----- Flash Code: 4/3

- The internal “12V” supply is out of range;
- 12V Supply is generated by the Motor control module and supplied to the GP400. Check for wiring errors between the two modules. If the fault remains, the Motor Controller may have to be replaced.

FAULT: BATTERY VOLTAGE TOO LOW! ----- Flash Code: 4/4

- The battery supply is too low – the batteries must be re-charged.

FAULT: BATTERY VOLTAGE TOO HIGH! ----- Flash Code: 4/4

- The battery supply is too high – check that the correct battery and charger are installed.

FAULT: BAD 5V SENSOR SUPPLY - CHECK P2-1 WIRING! ----- Flash Code: 4/5

- The “5V sensor” supply is out of range; this supply is available to power external 5V-powered sensors – check that it has not been overloaded or short-circuited to other wiring (CE models).

SENSOR Messages CE MODELS

The following are “sensor” HELP messages – problems have been detected which are likely due to sensor issues (CE models).

FAULT: CHECK HEIGHT1 SENSOR ----- Flash Code: 6/1

FAULT: CHECK HEIGHT2 SENSOR ----- Flash Code: 6/1

- A height sensor is giving an out-of-range voltage (below 0.5V or above 4.5V).

FAULT: CHECK HEIGHT SENSORS ----- Flash Code: 6/1

- When two height sensors are fitted, both should read the same height at all times; this message indicates that the sensors are reading different heights. Check for loose sensors and/or re-calibrate.

FAULT: CHECK PRESSURE SENSOR ----- Flash Code: 6/2

- A pressure sensor is giving an out-of-range voltage (below 0.5V or above 4.5V).

FAULT: CHECK ELEVATION SWITCH ----- Flash Code: 6/3

- The elevation switch is in disagreement with the height sensor(s).
- During calibration, the height at which the elevation switch opens (while lifting) and closes (while lowering), is recorded. Subsequently, height and these calibration points are continuously checked – any significant difference generates this error.
- This section lists “CANBUS” HELP messages – problems have been detected with Can-Bus communications between different modules (of course, only applicable if more than one module is connected together via CANbus):

FAULT: CAN BUS! ----- Flash Code: 6/6

- There are problems with CAN bus communications between the different modules; messages expected from one or more module are not being received, or messages intended to one or more module cannot be transmitted.
- Check for open- and short- circuit problems with CAN bus wiring; ensure that the CAN bus is wired correctly pin-to-pin; ensure that the vehicle chassis is not erroneously shorted to the chassis (for example, due to insulator breakdown in the motor).

POWER WIRING Messages

The following are “power wiring” HELP messages – problems have been detected which are likely due to power wiring errors:

FAULT: CAPBANK VOLTAGE TOO LOW - CHECK STUD WIRING! ----- Flash Code: 7/7

- The voltage on the B+ stud of the controller (connected to an internal voltage stabilization capacitor bank) is too low when the line contactor is off (a pre-charge circuit in the module normally applies approximately 32 volts to the capacitor bank).
- Check the 300 amp fuse, line contactor or power wiring for errors. Also check DC motor for internal grounding.

OTHER Messages

The following are other HELP messages:

SOME BIG BAD PROBLEM! ----- Flash Code: 9/9

- This message should not occur!

FACTORY OVERRIDE ----- Flash Code: (fast flashing)

- When the controller is first shipped, prior to initial calibration, it is configured in a special “factory override” state. In this state, none of the normal shutdowns or interlocks will occur – the vehicle can be freely lifted/ lowered and driven irrespective of any calibration needs, vehicle tilt, etc.
- As soon as an EZ-Cal is connected to the controller, the factory override state is ended.
- If calibration does not occur, then the factory override state will recur if the EZ-Cal is disconnected and power is switched off/on.

IMPORTANT: Never use a vehicle in factory override; this state is ONLY intended for use during manufacture! While factory override is active, the LED is rapidly flashed on/off.

TROUBLE TABLE

The following chart is a guide to help the technician find the area of a problem. In order to benefit from the information, you are advised to fully assess the symptoms by operating all machine functions. There may be some functions that operate while others may not. Record this information and proceed down the left-hand column until you find the failure scenario that best fits the problem. Refer to the information provided to the right for possible causes and remedies. This unit contains a Microprocessor based control system which contains various safety features designed to protect itself and the operator in the event of a failure.

The EZ-cal scan tool will provide the technician with detailed information related to the failure. It is strongly recommended that the technician use the EZ-cal to read any displayed messages before proceeding to use this Troubleshooting chart.

Information on the use of the EZ-cal tool plus helpful Flow Charts and graphs can be found earlier in the troubleshooting section. You are advised to read and familiarize yourself with all of the information provided in the troubleshooting section before attempting to diagnose or repair the 3072ES, 3772ES models.

TROUBLE Table

PROBLEM	POSSIBLE CAUSE	REMEDY/SOLUTION
General Power Issue		
No operation from upper or Upper Control station	Main battery switch turned off	Located left of Lower Controls
	Emergency switch pushed in or Ignition switch turned off	Upper or lower Emergency Stop switch will cut all power as will the ON/OFF switch in the Platform Controls box
	Batteries Discharged	Will receive 4-4 or 7-7 flash code on GP400. Clean, service and charge batteries.
	Blown 300 AMP fuse	Located left of lower controls. Check motor amperage draw. Will receive 7-7 flash code on GP400.
	Circuit breaker tripped	Located in Lower Controls panel. Possible catastrophic failure within motor controller.
	Damaged Upper Controls box harness	Inspect from harness plug to terminal strip under platform May receive 6-6 flash code on GP400 (CAN-bus)
	Other fault in system monitored by GP400	Check HELP and MODE message on EZ-Cal or check flash code error
Functions from Upper Controls but not from Upper Controls	Interlock switch (Joystick)	Check power to RED wire (power to switch) and power to PURPLE wire (power out of switch) at Joystick plug
	CAN-bus damaged	Check HELP or MODE message on EZ-Cal

continued...

TROUBLE Table continued

PROBLEM	POSSIBLE CAUSE	REMEDY/SOLUTION
Lift/Lower		
Platform will not Raise	Excessive weight on Platform	Reduce weight to within platform capacity
	Lift Relief valve out of adjustment	Adjust relief valve to rated capacity
	Lift Valve SV-1 not energized	Check wiring to lift valve Check EZ-Cal message or flash code
	Lowering valve SV-5 stuck open (located at base of lift cylinder/s)	Check and remove contamination from valve/s. E-Down cable damaged (3072ES only)
	Level Sensor out of level (platform elevated above 10 feet)	Reposition machine to firm level surface. Check level sensor function using EZ-Cal
	Main system pressure inadequate	Check pump output pressure
	Batteries Discharged	Check battery voltage. Clean, service and charge batteries.
	System Interruption	Check HELP or MODE message on EZ-Cal
Platform will not lower or lowers slowly	Maintenance Lock in maintenance position	Return Maintenance Lock to the stowed position
	Lowering valve not energized	Check wiring to lowering valve/s located on lift cylinder/s. Check for EZ-Cal message or flash code
	Lowering valve not shifting	Clean debris. Check for damage. Replace
	Lowering orifice (ORF-3) plugged	Clean orifice/s located inside hose fitting on each lift cylinder.
	System Interruption	Check HELP or MODE message on EZ-Cal
Lowers but not completely (3772ES)	Down valve on one cylinder inoperative	Check valve coils as described in <i>Platform will not lower or lowers slowly</i>
Emergency lowering not working	E-Down cable broken or frayed (3072)	Replace E-Down cable
	Lowering valve not shifting	Clean debris. Check for damage. Replace
	Lowering orifice plugged	Clean orifice
3772ES ONLY	E-Down battery discharged	Charge battery. Check charge diode & connections
	Valve coil failed on either cylinder	Test, replace
Lowers but not completely	Down valve on one cylinder inoperative	Check valve coils, wiring

continued...



TROUBLE Table continued

PROBLEM	POSSIBLE CAUSE	REMEDY/SOLUTION
Drive		
No drive function	1 or more outriggers deployed partially or fully (outrigger equipped models only)	Check for GREEN LED on upper control box Operate outrigger retract switch until electric automatically turns off
	Outrigger switch/s inoperative	Check enable light on platform control box Check outrigger switches located on top of each outrigger jack Check switch inputs using EZ-Cal (EZ-Cal ID# 2d7 – 2d10)
	Drive valve not shifting	Check connections at valve Check drive valve for contamination
	Drive system shut down or interrupted	Check HELP and MODE message on EZ-Cal
No drive elevated	Unit out of level	Alarm will sound Lower and reposition the machine.
	Low battery Voltage	Check battery voltage with multi-meter or EZ-Cal. Clean, service, charge batteries.
	System Interruption	Check HELP and MODE message on EZ-Cal
Slow drive with Platform stowed	High torque enabled	Check Speed/Torque switch on platform controls
	Limit switch not functioning	Check limit switch located on left rear of base Check limit switch input with EZ-Cal (EZ-Cal ID# 2d5)
	Malfunctioning rear wheel bypass valve	Located on rear wheels only Check by replacing valves.
	Wheel motors not functioning correctly	Inspect wheel motors for excessive bypass.
Poor gradability performance	High or mid speed enabled	Check Speed/Torque switch on platform controls
	Batteries discharged	Check battery voltage with multi-meter or EZ-Cal. Clean, service, charge batteries.
	Wheel motors not functioning correctly	Inspect wheel motors for excessive bypass.
	Malfunctioning rear wheel bypass valve	Located on rear wheels only Check electrical by disconnecting valves. Check function by replacing valves.
	Malfunctioning series parallel valves	Located on top of main hydraulic manifold
	Worn hydraulic pump	Check with flow meter or replace pump.
Drive in one direction only	Drive valve SVD1 not energized in one direction	Check 12 volts to appropriate coil Check coil Check valve function
	Counterbalance valve CBV1 or CBV2 not functioning correctly	Swap counterbalance valves to see if functioning direction changes.
	No output from GP400	Scan using EZ-Cal and troubleshooting charts EZ-Cal chart ID# 4f-7 – FWD or 2f-9 – Reverse

continued...

TROUBLE Table continued

PROBLEM	POSSIBLE CAUSE	REMEDY/SOLUTION
Drive		
No low speed (high torque mode)	Speed/Torque switch inoperative	Check for 12 volts on terminals 2 & 3 of Speed/Torque switch in platform control box with drive enabled.
	Valve SV3 not functioning	Check for 12 volts to valve Check ground to valve Check for faulty valve spool
	EP1 poppet valve not functioning	Check or replace vavle.
No Mid Speed	SV3 or SV4 powered and/or shifted	These valves should not have 12 volts. In mid-speed, check valve function
	Speed/Torque selector switch malfunction	Should not have power at terminals 1 & 3 of Speed/Torque switch in Platform Controls box with drive enabled
No High Speed	Speed/Torque selector switch inoperative	Check for 12 volts on all terminals of Speed/Torque switch in Platform Controls box with drive enabled.
	Valve SV4 not functioning	Check voltage and ground to valve check for faulty valve spool
	EP2 poppet valve not functioning	Check or replace valve
No Speed Selection	Limit switch not functioning	Check limit switch located on left rear of base Check limit switch input with EZ-Cal (EZ-Cal ID# 2d5)
Steer		
No steer in either direction	Joystick rocker switch inoperative	Check rocker switch output; OUTPUT - green and yellow wires. INPUT - blue wire
	Steering valve inoperative	Check steering valve for power or damage.
	System Interruption	Check HELP and MODE message on EZ-Cal
	Hoses connected incorrectly	See hydraulic section for proper connection.
	Pressure relief valve set too low	Set steer relief valve to 2000 p.s.i.
Steers in one direction only	Steering valve inoperative or stuck	Inspect – replace steering valve
	No power to steering coil	Check for power and grounding in both directions. Repair wiring
	System Interruption	Check HELP and MODE message on EZ-Cal
Steers, but not fully, or steers slowly	One or both steering cylinder/s internal seal failure	Check steering cylinder seals – replace
	Pressure relief valve set too low	Set steer relief valve to 2000 p.s.i.
	King pin/s seizing in the bore	Disassemble and inspect Repair Replace bushings

continued...

TROUBLE Table continued

PROBLEM	POSSIBLE CAUSE	REMEDY/SOLUTION
Outrigger		
No outrigger operation	Limit Switch LS-1 Senses platform is in elevated position	Check limit switch LS1 located L/R base area. Check Limit Switch switch input using EZ-cal (EZ-Cal ID# 2d5)
	System Interruption	Check HELP and MODE message on EZ-Cal
	Outrigger switch inoperative	Check outrigger switch located in the upper control box
	Directional pressure Valve not functioning	Located behind lower control box. Inspect valve for power or damage.
Outriggers deploy unevenly and/or unit will not level	Unit on too extreme angle	Relocate unit to more level ground
	Outrigger extend valve sticking open	Inspect/replace deploy valve found atop each outrigger cylinder (see outrigger section for valve identification)
	Pressure switch stuck closed	Check pressure switches with outriggers retracted switches should be open
	Tilt sensor not calibrated or not calibrated properly	First assure that the unit is level. Use EZ-cal, Access level 2, SETUPS, TILT to Calibrate.
	Outrigger legs wired incorrectly or plug P6-1 - 10 or P15-1 - 11 pined incorrectly	Correct wiring, refer to schematic diagram for correct wiring.
	Damage to one or more outrigger legs	Inspect and replace as needed.
	Outrigger hoses connected incorrectly	See outrigger section for hose routing detail
	Pressure relief valve set too low	Set STEER relief valve to 2000 p.s.i.
NOTE: To test for proper switch and solenoid operation and wire routing, follow the outrigger test sequence found in <i>Ez-Cal Outrigger Test Mode</i> on page 4- 18.		

HYDRAULIC PRESSURE ADJUSTMENT PROCEDURES

- Before attempting to check and/or adjust pressure relief valves, operate the machine for 15 minutes or long enough to sufficiently warm the hydraulic fluid.
- Insert a 0-5000 psi gauge onto the pressure test port on the valve manifold using gauge adapter fitting MEC part no. 8434

Pressure Adjustment Table

MODEL	MAIN	LIFT	STEER
3072ES	2800 PSI 193 bar	2500 PSI 172.4 bar	2000 PSI 137.9 bar
3772ES	2800 PSI 193 bar	2500 PSI 172.4 bar	2000 PSI 137.9 bar
3772ES HD	3000 PSI 206.8 bar	2500 PSI 172.4 bar	2000 PSI 137.9 bar

Adjusting Relief Valves

- Remove the tamper proof cap.
- Turn adjustment screw "IN" to increase pressure.
- Turn adjustment screw "OUT" to decrease pressure.
- When correct pressure is obtained replace tamper proof cap with a new one.

Caution: Do not operate pump with tamper proof cap removed as fluid will emit under pressure.

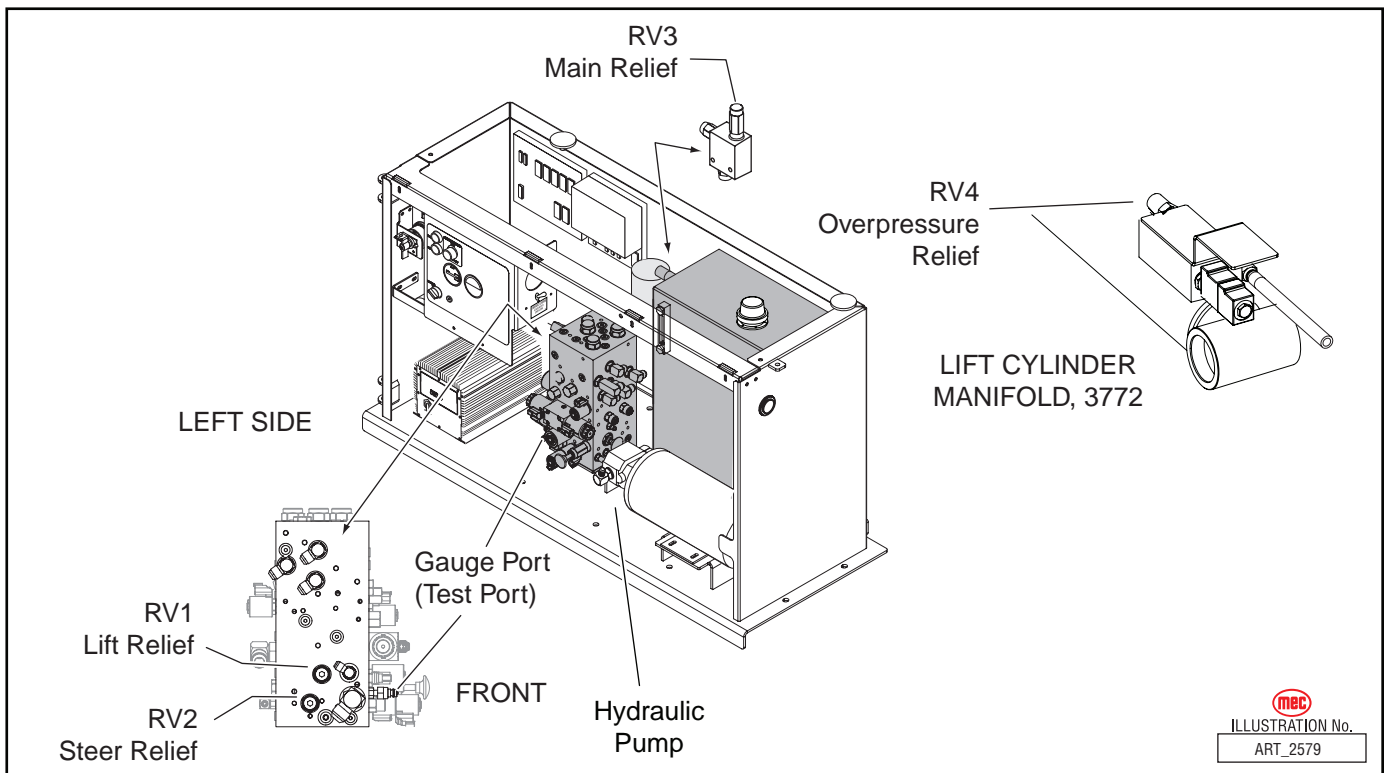

Main (RV3)

- Disconnect forward or reverse coil of drive valve.
- Energize drive function by moving joystick in the direction of the already disconnected coil.
- Hold the switch for 10 seconds to get an accurate reading on the pressure gauge.
- If pressure is LOW, adjust main relief valve $\frac{1}{4}$ turn clockwise and recheck.
- If pressure is HIGH, adjust main relief valve $\frac{1}{4}$ turn counterclockwise and recheck.
- Repeat until correct.

Lift Relief (RV1)

- Energize the platform to full extension with **no load on platform**.
- Hold the switch for 10 seconds to get an accurate reading on the pressure gauge.
- If pressure is LOW, adjust lift relief valve $\frac{1}{4}$ turn clockwise and recheck.
- If pressure is HIGH, adjust lift relief valve $\frac{1}{4}$ turn counterclockwise and recheck.
- Repeat until correct.

Steering Relief (RV2)

- Energize the steering to full left.
- Hold the switch for 10 seconds to get an accurate reading on the pressure gauge.
- If pressure is LOW, adjust steering relief valve $\frac{1}{4}$ turn clockwise and recheck.
- If pressure is HIGH, adjust steering relief valve $\frac{1}{4}$ turn counterclockwise and recheck.
- Repeat until correct.

Lift Cylinder Overpressure Valves (RV4) 3772ES Only

The Lift Cylinder Overpressure valves are located on each of the lift cylinder valve blocks on the 3772ES model only.

Proper valve adjustment is not possible by the consumer. Considering their importance to the safe operation of the machine, they must not be tampered with. If the valve is suspected to be out of adjustment or tampered with, it must be replaced.

Setting Counterbalance Valves

1. Loosen the locknut on one of the valves.
2. Turn the adjustment screw counterclockwise (to the left) until it reaches the internal stop and the screw will turn no further.
3. Turn the adjustment screw clockwise (to the right) $2\frac{3}{4}$ turns.
4. Tighten the locknut while holding the adjustment screw in position to prevent it from rotating.
5. Repeat steps 1 through 4 on the other Counterbalance valve.
6. Adjustment is complete.

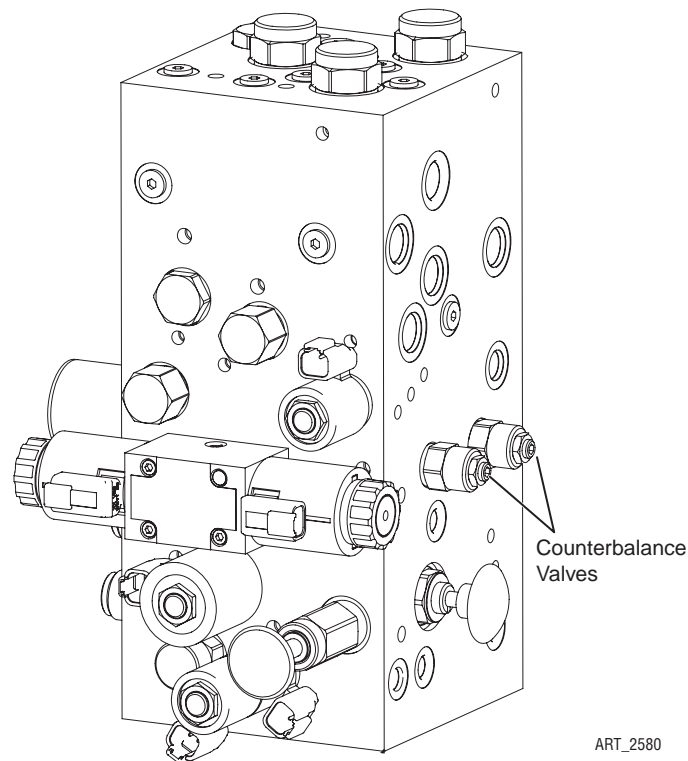

ART_2580

TROUBLESHOOTING BATTERY CHARGER

Insufficient AC system, poor connections, bad batteries or low electrolyte in batteries may result in poor charger performance. Refer to *Section 2: Electrical System* for electrical requirements, and charger and battery maintenance instructions.

Refer to the *Operator's Manual* for detailed charging instructions.

To be able to use the trouble shooting guide safely and effectively, it is important to read through this guide before beginning any tests.



Do not operate the charger if it is malfunctioning. Personal injury or property damage may result.

Do not disassemble charger. Return to MEC when service or repair is required.

To reduce the risk of fire, only use AC circuits and extension cords in accordance with all National and Local Electrical Codes for the location of use.

Only use MEC approved lead acid type flooded batteries. Use of GEL type batteries may damage the charger and cause machine instability due to decreased weight.



TO REDUCE THE RISK OF ELECTRIC SHOCK, ALWAYS DISCONNECT BOTH THE POWER SUPPLY CORD AND THE OUTPUT WIRES BEFORE ATTEMPTING MAINTENANCE.

THE CHARGER SURFACE CAN GET HOT WHILE OPERATING. CONTACT WITH THE SKIN OR SURROUNDING MATERIALS SHOULD BE AVOIDED.

TO REDUCE THE RISK OF AN ELECTRIC SHOCK, CONNECT ONLY TO A PROPERLY GROUNDED SINGLE-PHASE (3 WIRE) OUTLET.

Incorrect assembly may result in a risk of electric shock or fire. The following procedures are intended only to determine if a malfunction may exist in the charger. Most returned chargers test good, it is very important that this procedure is followed and that other problems are corrected before assuming the charger has failed.

The MEC battery charger is a fully automatic type with a maintenance feature that will maintain battery voltage indefinitely when connected to an AC power source. The battery charger should be plugged into an unswitched AC power source if the machine is stored for long periods of time.

IMPORTANT: All MEC electric scissor lifts are equipped with lead acid type flooded batteries. The yellow wire loop on the back of the charger must be intact. If it is cut, broken or damaged the charger may go into GEL charging mode, causing damage to the machine and/or batteries.

Single Battery Charger, HB1500-48

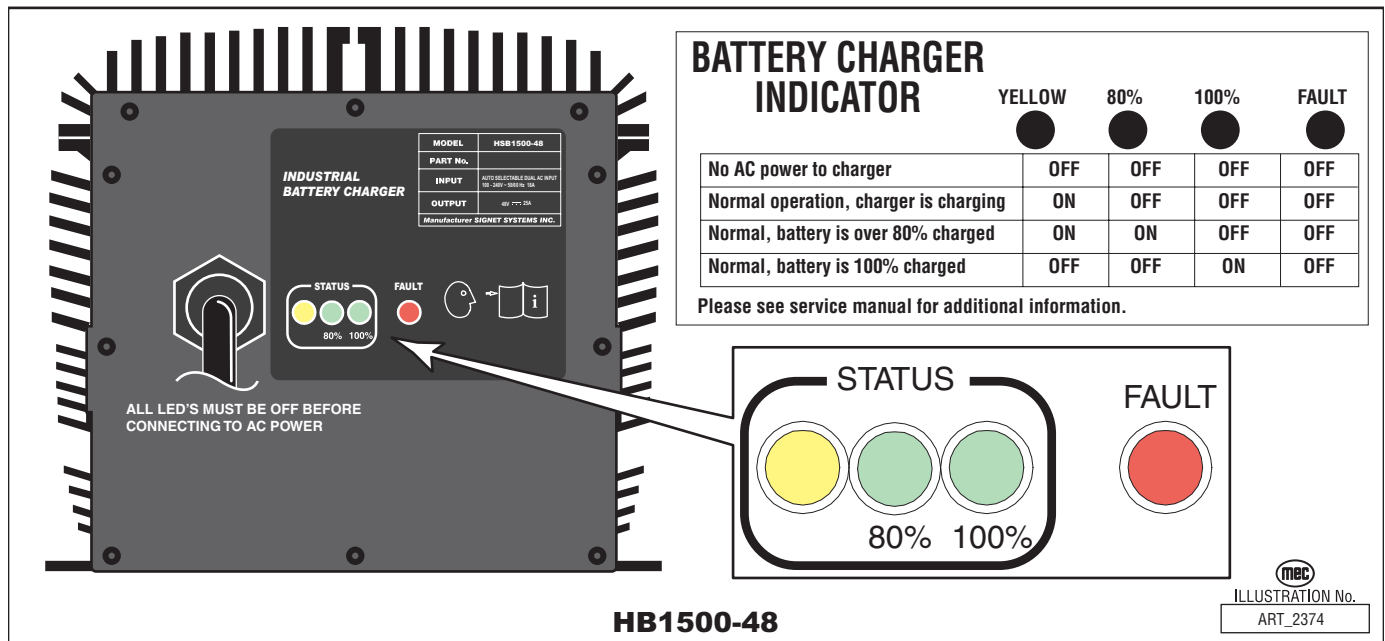

Fault Codes

CHG YELLOW LED	80% GREEN LED	100% GREEN LED	Fault RED LED	Condition
X	X	X	ON	- Battery pack probably bad - Weak or bad cell
OFF	OFF	OFF	ONE FLASH	- Output open circuit or short circuit or reverse polarity connection of charger to battery - Battery voltage is too high (may be connected to wrong voltage battery)
OFF	OFF	OFF	TWO FLASH	- Charger has timed-out at 22 hours – battery pack probably bad or bad cell.
X = "don't care" LED may be ON or OFF				

To determine if a charger is malfunctioning, identify the problem from the following list and refer to the Trouble Table for instructions.

1. Charger does not turn ON -or- no yellow LED
2. Red FAULT LED is ON or BLINKING
3. Batteries do not fully charge
4. The AC supply circuit breaker is tripped or fuse is blown

If the problem is not listed above, refer the problem to a qualified service agent for additional trouble shooting procedures.

Note: Over 1/2 of all battery chargers returned as "failed" are good. Please follow the troubleshooting procedures carefully and check all other items before returning the charger.

Trouble Table, HB1500-48 Battery Charger

PROBLEM	DIAGNOSIS
<p>Charger does not turn ON</p>	<p>The AC plug must be disconnected and reconnected to start the charger once it has turned-off from a charge cycle.</p> <ul style="list-style-type: none"> • Connect the AC supply cord securely to a live AC outlet. • Check the AC outlet to ensure it is working. • Check that DC output wires and connections are in good working condition. • Replace charger if everything else is correct.
<p>Red FAULT LED is ON or BLINKING</p>	<p>The faults identified below cause the FAULT LED to turn ON or BLINK. If the cause of the fault is removed the charger restarts automatically.</p> <ul style="list-style-type: none"> • LED is ON Weak or bad battery pack, bad cell, or low electrolyte level. • LED blinks once: OUTPUT CONNECTION ERROR Check Battery and Charger Connection <ul style="list-style-type: none"> - Connection may be corroded or loose - Check for pinched or broken wires (may cause a short) - Output may be connected in reverse polarity to batteries (the charger is not damaged by any of these problems.)
<p>Red FAULT LED BLINKS twice: charger has Timed-Out</p>	<p>The charger has a 22 hour timer - if charge cycle is not complete within 22 hours the charger will stop charging.</p> <ul style="list-style-type: none"> • Possible Causes: <ul style="list-style-type: none"> - Batteries are extremely discharged - unplug for 30 seconds then plug charger back in to restart and complete charging. - Electrolyte is low in one or more cells. - Batteries are weak, old, or have one or more bad cells. Batteries will still charge but in a weakened capacity - they should be replaced.
<p>Batteries do not fully charge</p>	<ul style="list-style-type: none"> • Overnight Charging Make sure AC power supply is not being switch OFF at night • NEW batteries New batteries sometimes require 20 to 30 charge/discharge cycles before they charge normally. 80% LED after overnight charging is normal. Within a few weeks the 100% LED should light after overnight charge. • OLD batteries Check for dead cells or reduced capacity.
<p>AC Line circuit breaker tripped or fuse blown</p>	<ul style="list-style-type: none"> • Overloaded Circuit Plug charger into a different AC outlet on a different circuit. If charger operates properly the AC line may require repair. If charger fails and AC line checks "good" the charger should be replaced.

Dual Battery Chargers, HB750-24 (Early Models)

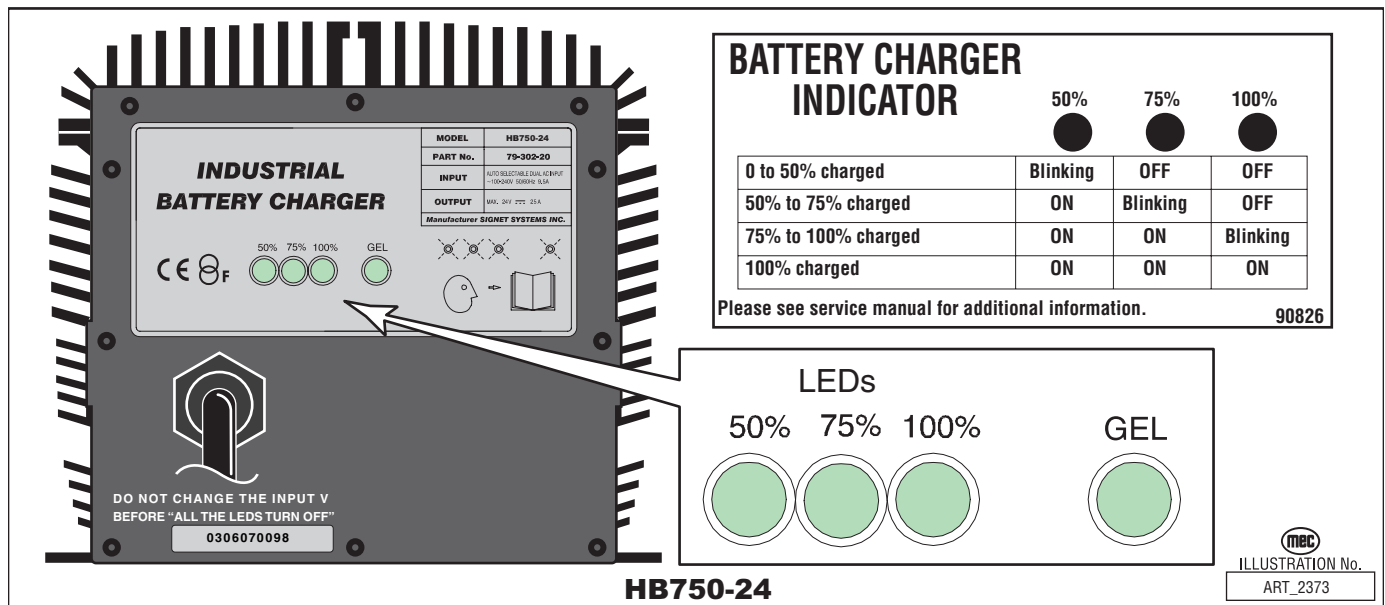

	LED Status	Description
Fault	All 3 LED lamps blink once simultaneously.	Output is open or short, or output voltage is over a limit. Otherwise, output terminals are reversed.
	All 3 LED lamps blink twice simultaneously.	Input voltage is out of the range
	All 3 LED lamps blink three times simultaneously.	The internal temperature of the charger exceeds a limit.
	All 3 LED lamps blink four times simultaneously.	Output current exceeds a limit.
Warning	100% LED lamp blinks.	Battery pack has a bad cell.
Operation Mode	GEL LED ON	Charger in GEL mode. Yellow wire loop on back of charger damaged, cut or broken.

To determine if a charger is malfunctioning, identify the problem from the following list and refer to the *Trouble Table* for instructions.

1. Charger does not turn on
2. All 3 LEDs blink simultaneously
3. 100% LED blinks while 50% and 75% LEDs are OFF
4. Batteries do not fully charge
5. The AC supply circuit breaker or fuse is blown
6. GEL LED is ON.

If the problem is not listed above, refer the problem to a qualified service agent for additional trouble shooting procedures.

Note: Over 1/2 of all battery chargers returned as "failed" are good. Please follow the troubleshooting procedures carefully and check all other items before returning the charger.

Trouble Table, HB750-24 Battery Charger

PROBLEM	DIAGNOSIS
Charger does not turn ON	<p>The AC plug must be disconnected and reconnected to start the charger once it has turned-off from a charge cycle.</p> <ul style="list-style-type: none"> • Connect the AC supply cord securely to a live AC outlet. • Double check the outlet to ensure it is working by connecting a known good piece of equipment with the outlet. • Inspect the DC output wires and connections to be sure they are in good working condition. • Refer to LED Flash Codes below if all 3 LEDs are flashing. • Replace charger if everything else is correct.
All 3 LEDs blink ONCE simultaneously	<p>Output connection error.</p> <ul style="list-style-type: none"> • Check the battery and charger connection and correct • The output may not be connected to the batteries • The connections to the batteries may have corroded or loosened. • The output may be shorted due to improper connection to the batteries or pinched wires. • The output may be connected in reverse polarity to the batteries. <p>The charger will not be damaged by any of these problems.</p>
All 3 LEDs blink TWICE simultaneously	<p>AC input voltage tolerance beyond limit.</p> <ul style="list-style-type: none"> • Check the AC input voltage. The charger is indicating the AC voltage is too low or too high. <p>This is an unusual problem and would most likely occur with a very poorly regulated engine-generator set providing the AC voltage to the charger.</p>
All 3 LEDs blink THREE TIMES simultaneously	<p>Charger is overheated.</p> <ul style="list-style-type: none"> • No action required. When the charger cools, charging will restart automatically. • Check and correct for dirt or other debris on charger that may be reducing cooling.
All 3 LEDs blink FOUR TIMES simultaneously	<p>Input or output over current.</p> <ul style="list-style-type: none"> • No action required, charger will correct and restart automatically.
100% LED blinks while 50% and 75% LEDs are OFF	<p>The 18 hour timer has elapsed and stopped charging. Batteries are unable to complete constant current and constant voltage charge cycle.</p> <ul style="list-style-type: none"> • Batteries are weak, old, or have one or more bad cells. Batteries will still charge but capacity will be reduced. Replace batteries. • Battery pack too large for charger. Use higher output charger or unplug then plug-in charger to restart charge cycle to complete charging.

continued . . .

PROBLEM	DIAGNOSIS
<p>Batteries do not fully charge</p>	<p>If the batteries are charged overnight, make sure the AC supply is not being switched-off at night with other building items.</p> <ul style="list-style-type: none"> • Check battery condition following the battery supplier's instructions. • Check for dead cells or reduced capacity. • Replace charger only if other problems are not found.
<p>The AC line circuit breaker or fuse is blown</p>	<p>A defective circuit breaker or fuse, overloaded circuit, or a charger problem can cause this condition.</p> <ul style="list-style-type: none"> • Connect the charger to a different AC outlet (on a different circuit) in the building. • If the charger operates properly on other AC outlets, a qualified Person should correct the AC outlet problem. • If the AC supply checks good, the charger should be replaced.
<p>GEL LED is ON</p>	<p>The yellow wire loop on the back of the charger is damaged, broken or cut, putting the charger in GEL (sealed) type charging mode.</p> <ul style="list-style-type: none"> • Repair the wire. • If GEL LED remains ON, the charger should be replaced.





SECTION 5

SCHEMATICS

Hydraulic Schematic	5-2
Main Hydraulic Manifold.....	5-4
Main Relief Hydraulic Manifold	5-5
Optional Outriggers Hydraulic Manifold	5-5
Electric System	5-6
Electric Schematics: Upper Controls, Early Models	5-6
Electric Schematics: Upper Controls, Current Models	5-7
Electric Schematics: Base	5-8
P600 Motor Control Module	5-9
GP400 Matrix Module	5-10
Matrix Module Controller.....	5-11

HYDRAULIC SCHEMATIC

Callout	Description
	Lift Cylinder Components (3072ES)
CYL2	Cylinder
MA3	Manifold, Lift Cylinder
SV5	Solenoid Valve - 12V Cable Attach
ORF3	Orifice - 0.067
	Lift Cylinder Components (3772ES)
CYL3	Cylinder, Upper
MA5	Manifold, Lift Cylinder, Upper
SV6	Solenoid Valve - 12V Dual Coil
RV4	Relief Valve - 3200 PSI
ORF4	Orifice - 0.067
CYL4	Cylinder, Lower
MA4	Manifold, Lift Cylinder, Lower
SV6	Solenoid Valve - 12V Dual Coil
RV4	Relief Valve - 3200 PSI
ORF6	Orifice - 0.042
	Wheel Motor Components
LF	Wheel Motor - Left Front
LR	Wheel Motor - Left Rear
SV10	Solenoid Valve – Cross Port Valve
RF	Wheel Motor - Right Front
RR	Wheel Motor - Right Rear
SV10	Solenoid Valve – Cross Port Valve
P1	Pump - Fixed Displacement
FL1	Return Filter - 10 Micron
CYL1	Cylinder, Steering
	Optional Outriggers Components
CYL5	Outrigger Cylinder
SV7	Solenoid Valve, Poppet N.C.
SV8	Solenoid Valve, Poppet N.C.
SV9	Spool Valve, 4-way, - 3-Position

Callout	Description
	Manifold Components
MA1	Manifold, Main Valve Block
SVD1	Spool Valve, Drive, 4-Way - 3-Position
SV1	Spool Valve, Lift, 3-Way
SV2	Spool Valve, Steer, 4-Way - 3-Position
SV3 - SV4	Spool Valve, Series Parallel, 4-Way - 3-Position
RV1	Relief Valve, Lift - 2500 PSI
RV2	Relief Valve, Steer - 1500 PSI
PD1 - PD2 - PD3	Piloted Spool Valve, 4-Way - 3-Position
EP1 - EP2	Piloted Poppet Valve
MP1	Manual Pull Valve
LS1 - LS2 - LS3	Load Sense Shuttle Check Valve
CBV1 - CBV2	Counter Balance Valve
CL1	Coil, Series 8 - 12V
CL2	Coil, Series 10 - 12V
CL3	Coil, Series 10 E-Coil - 12V
HP1	Hand Pump, Brake Release
FD1 - FD2	Flow Divider / Combiner
EC1	Pressure Compensator
CV1 - CV2	Check Valve, Load Sense
OD1	Orifice Disc, Brake - 0.035
OPL2	Orifice Plug, Steer - 0.080
OPL5 - OPL6	Orifice Plug, Flow Divider Bleed - 0.025
ORF5	Orifice, Steer Control - 0.064
	Main Relief Manifold
RV3	Main Relief Valve



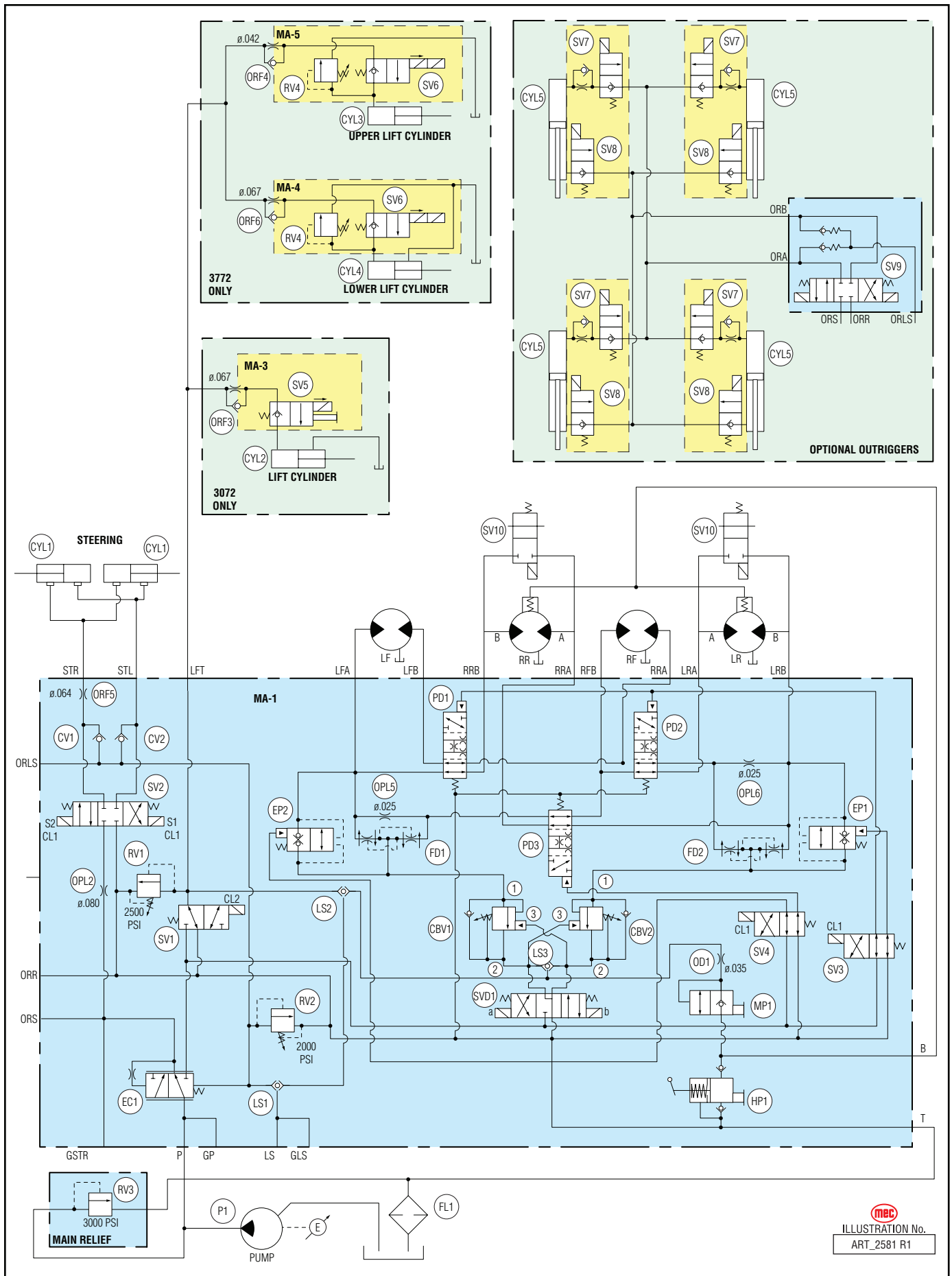

mec
ILLUSTRATION No.
ART_2581 R1

Main Hydraulic Manifold

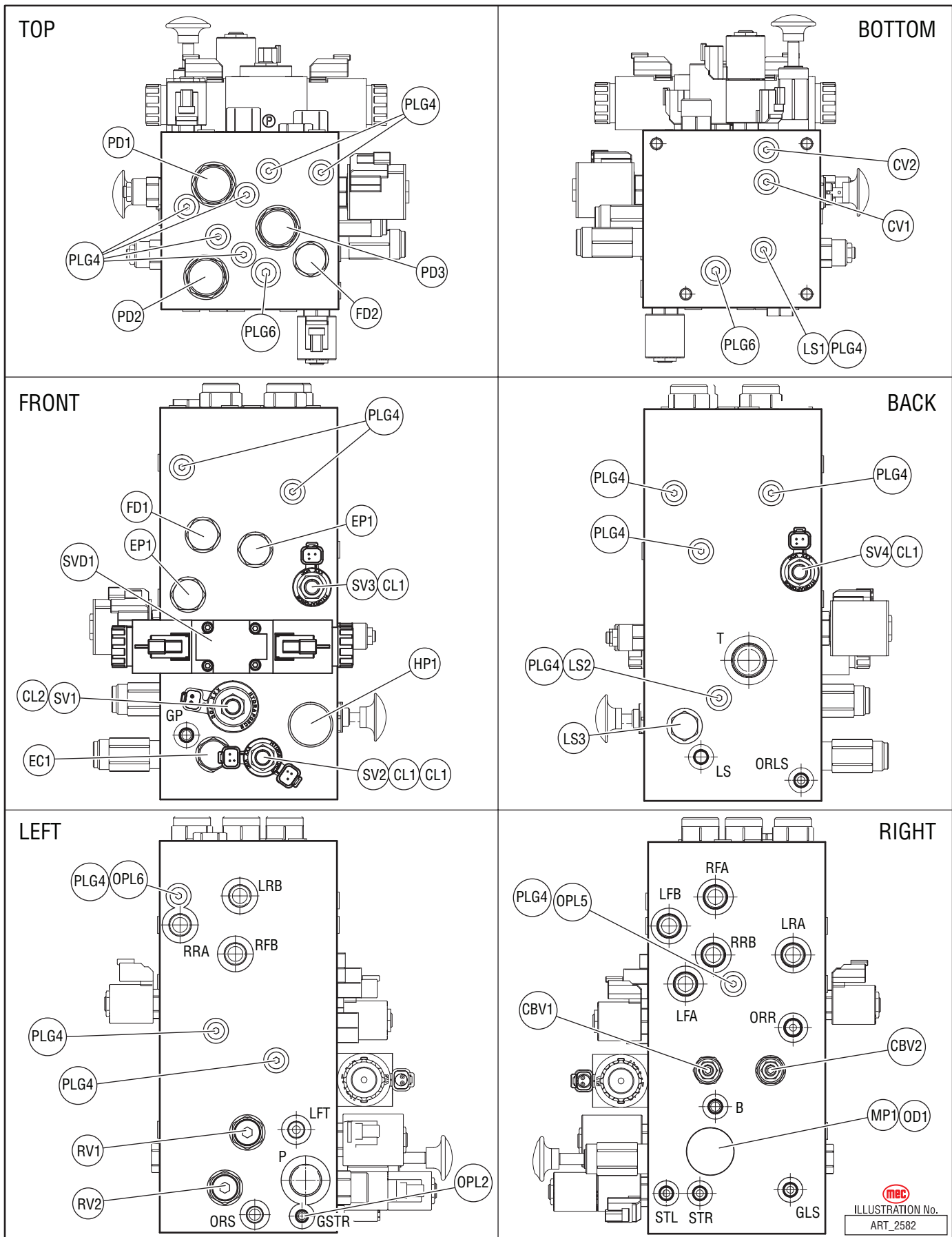
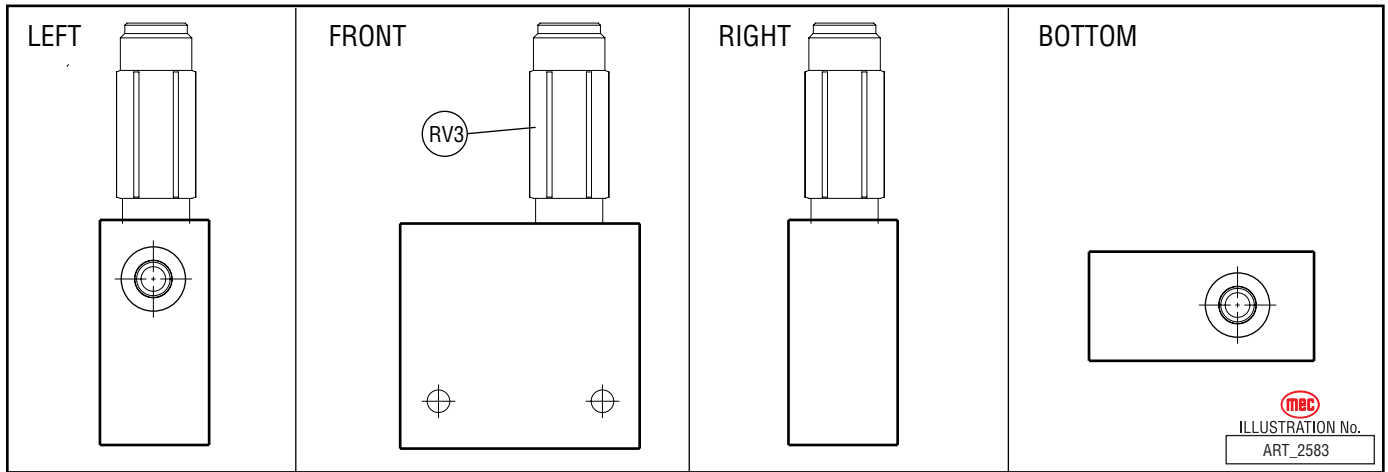
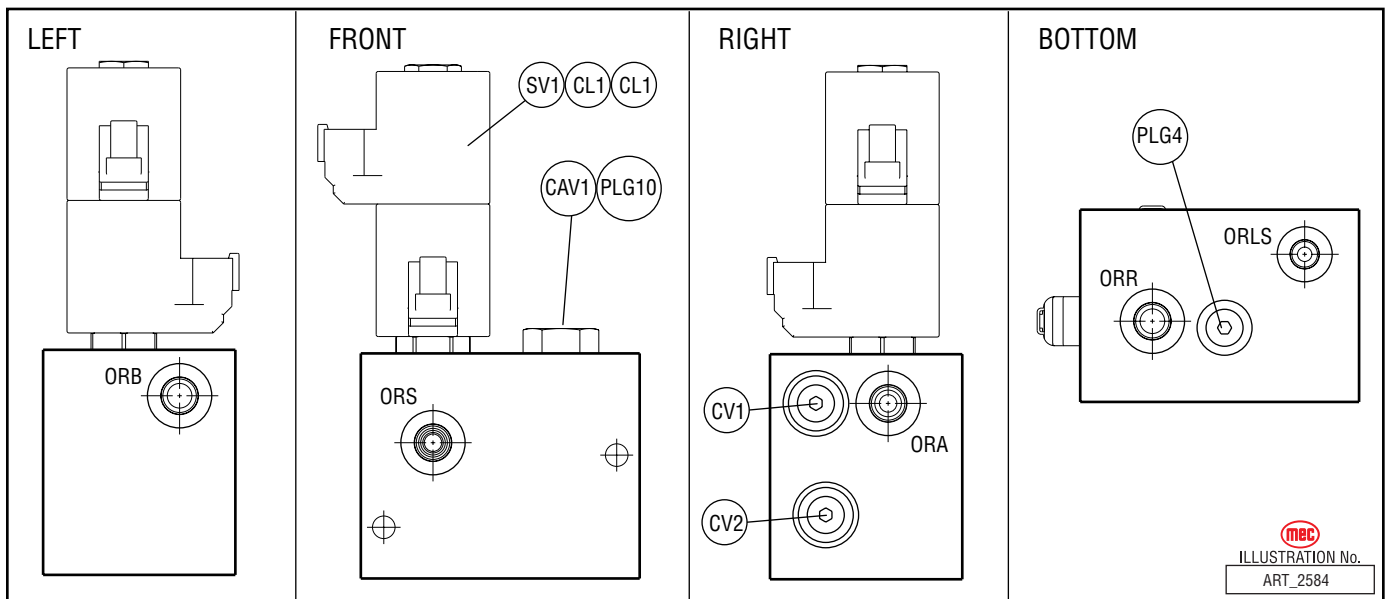

ILLUSTRATION No.
ART_2582

Main Relief Hydraulic Manifold



Optional Outriggers Hydraulic Manifold



ELECTRIC SYSTEM

Electric Schematics: Upper Controls, Early Models

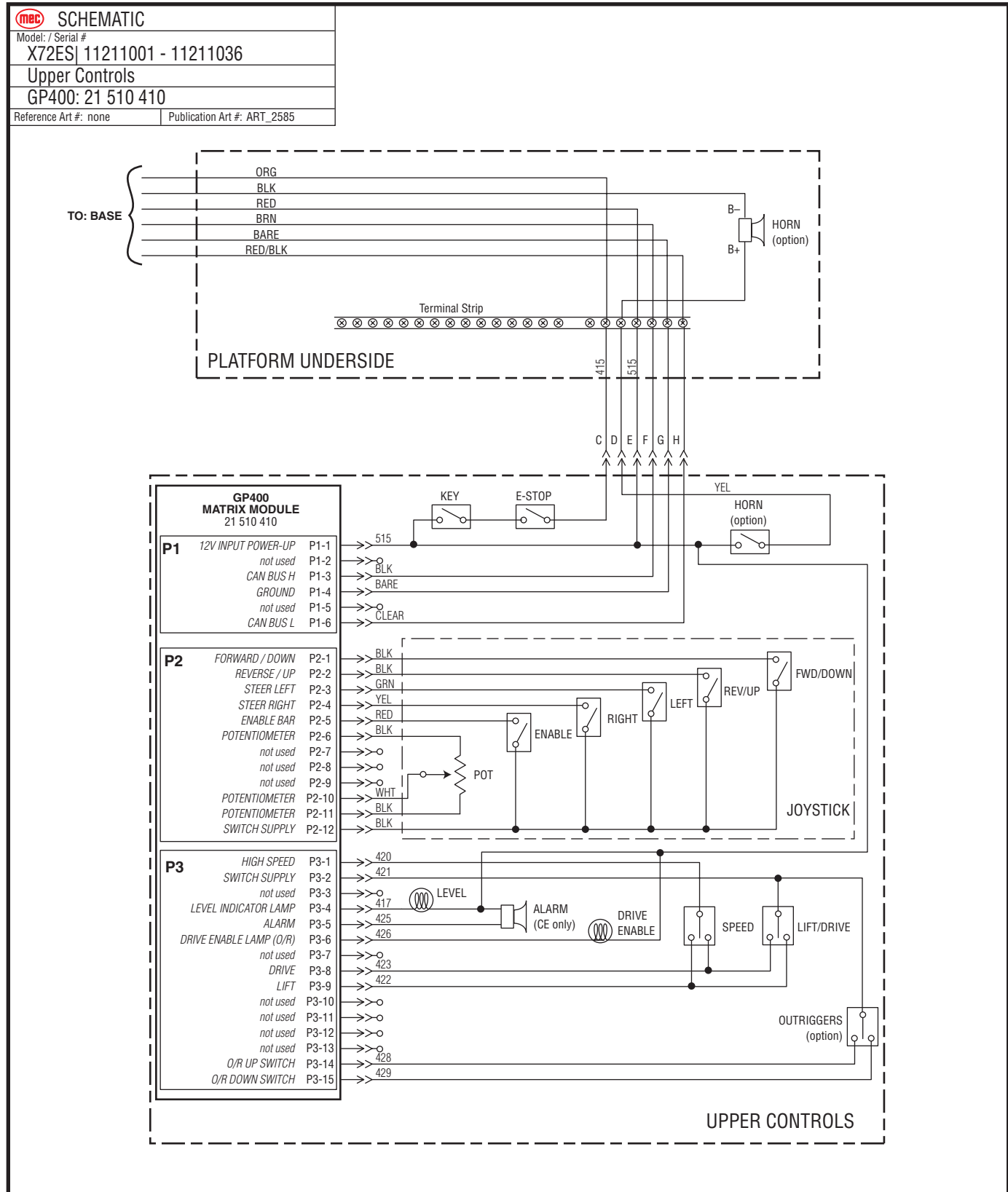

Electric Schematics: Upper Controls, Current Models

MBC SCHEMATIC	
Model / Serial # X72ES 11211037 - UP	
Upper Controls GP400: 21 510 411	
Reference Art #: none	Publication Art #: ART_2586

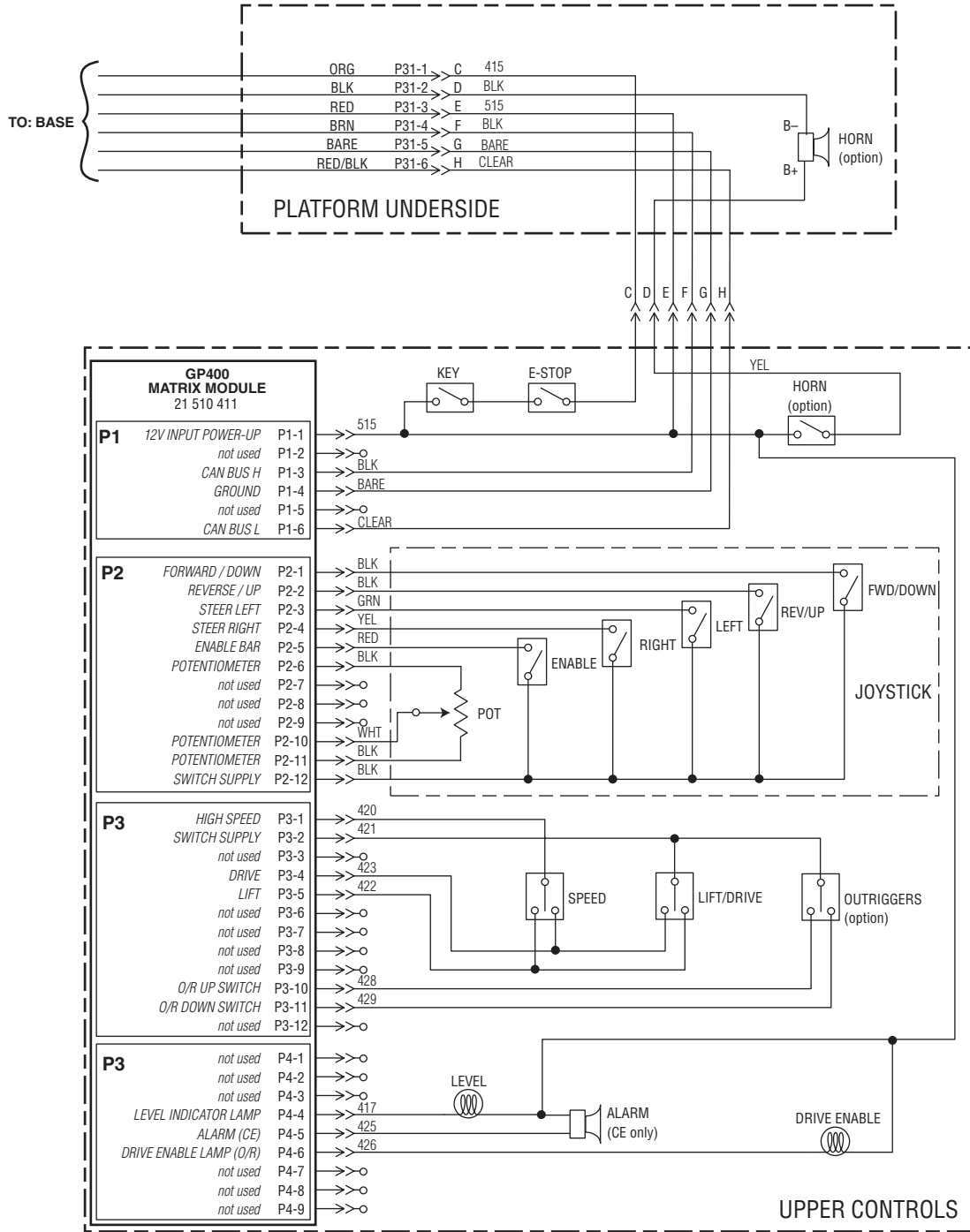

Electric Schematics: Base

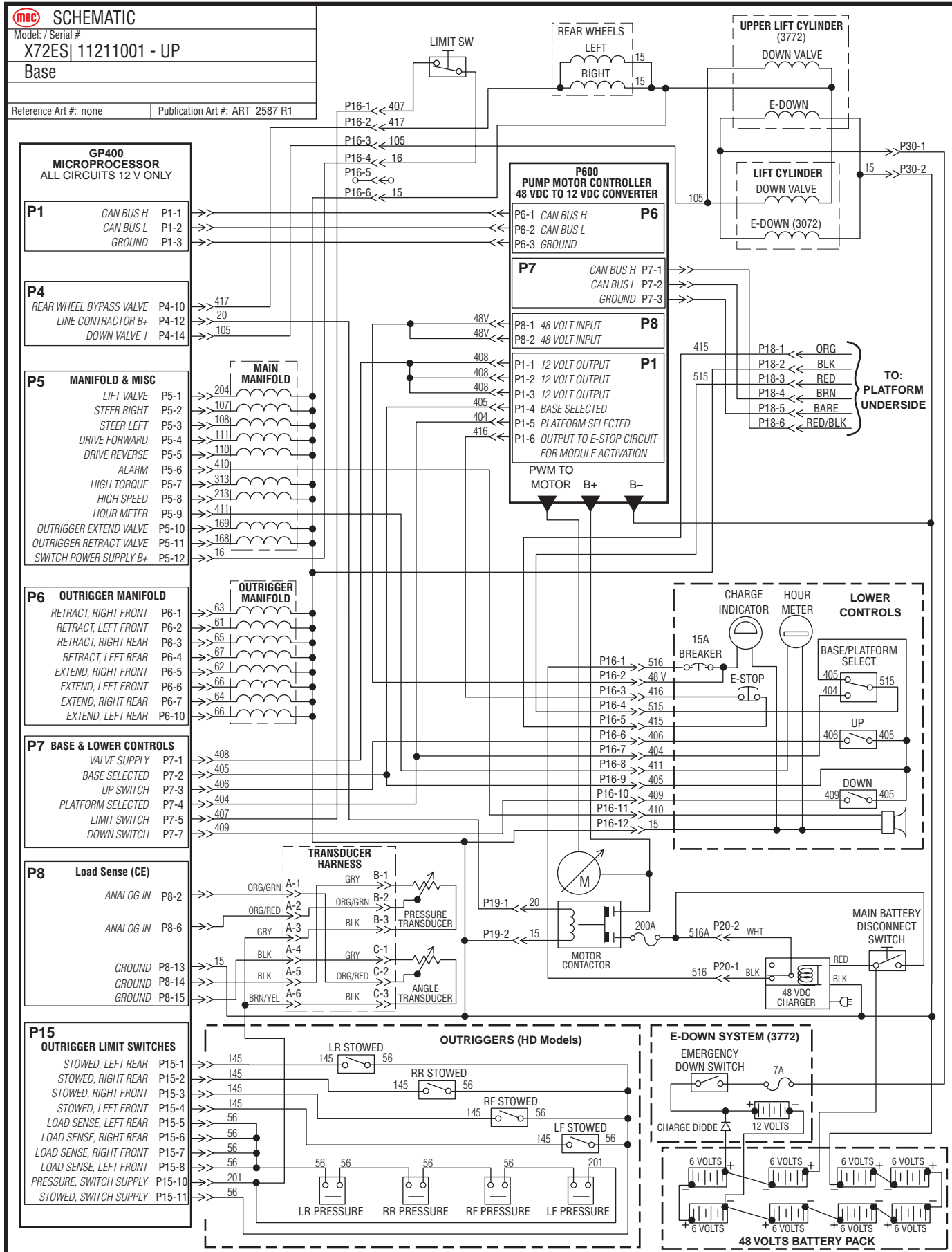

P600 Motor Control Module

Located in Control Module behind lower controls.

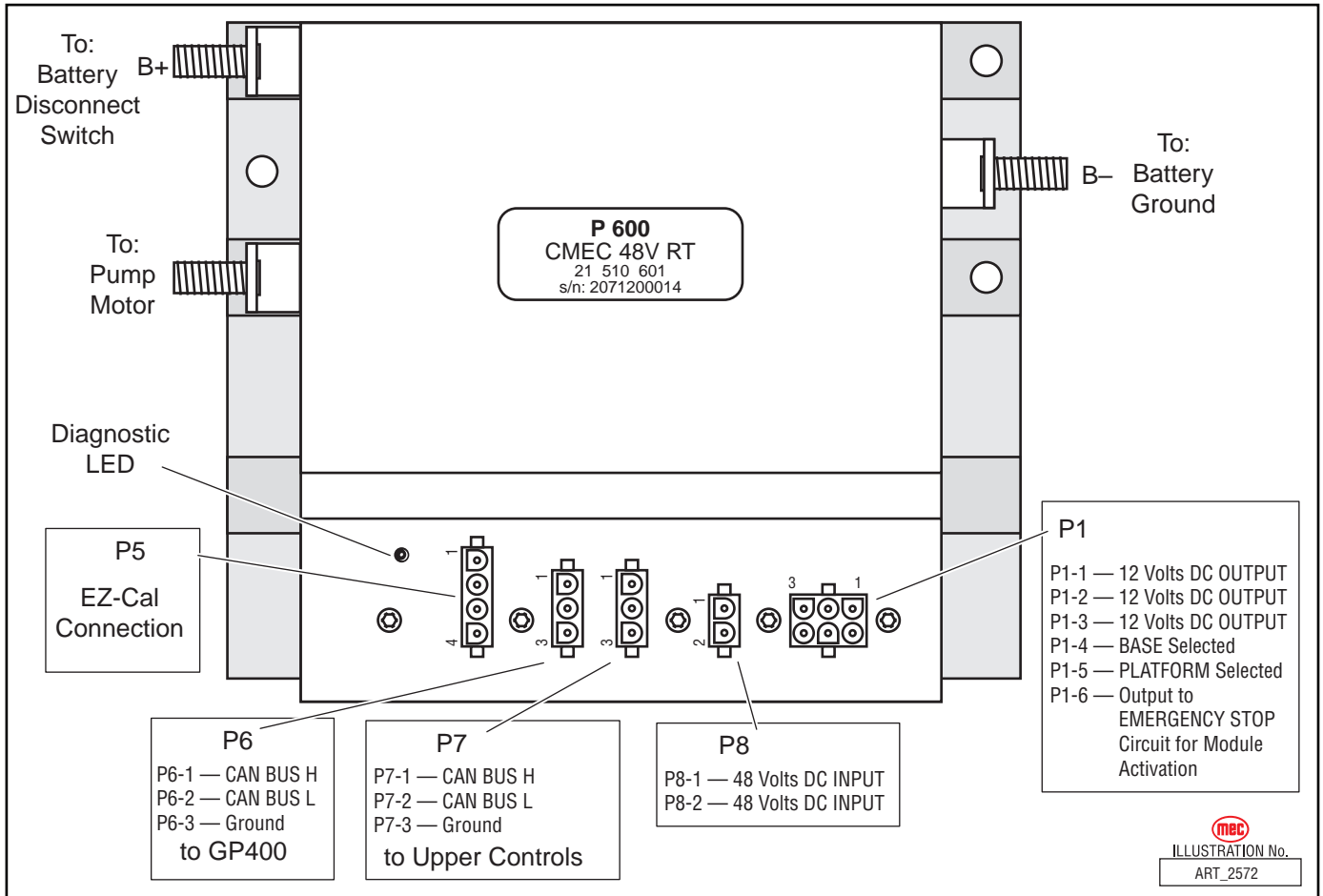

GP400 Matrix Module

Located in Control Module behind lower controls.

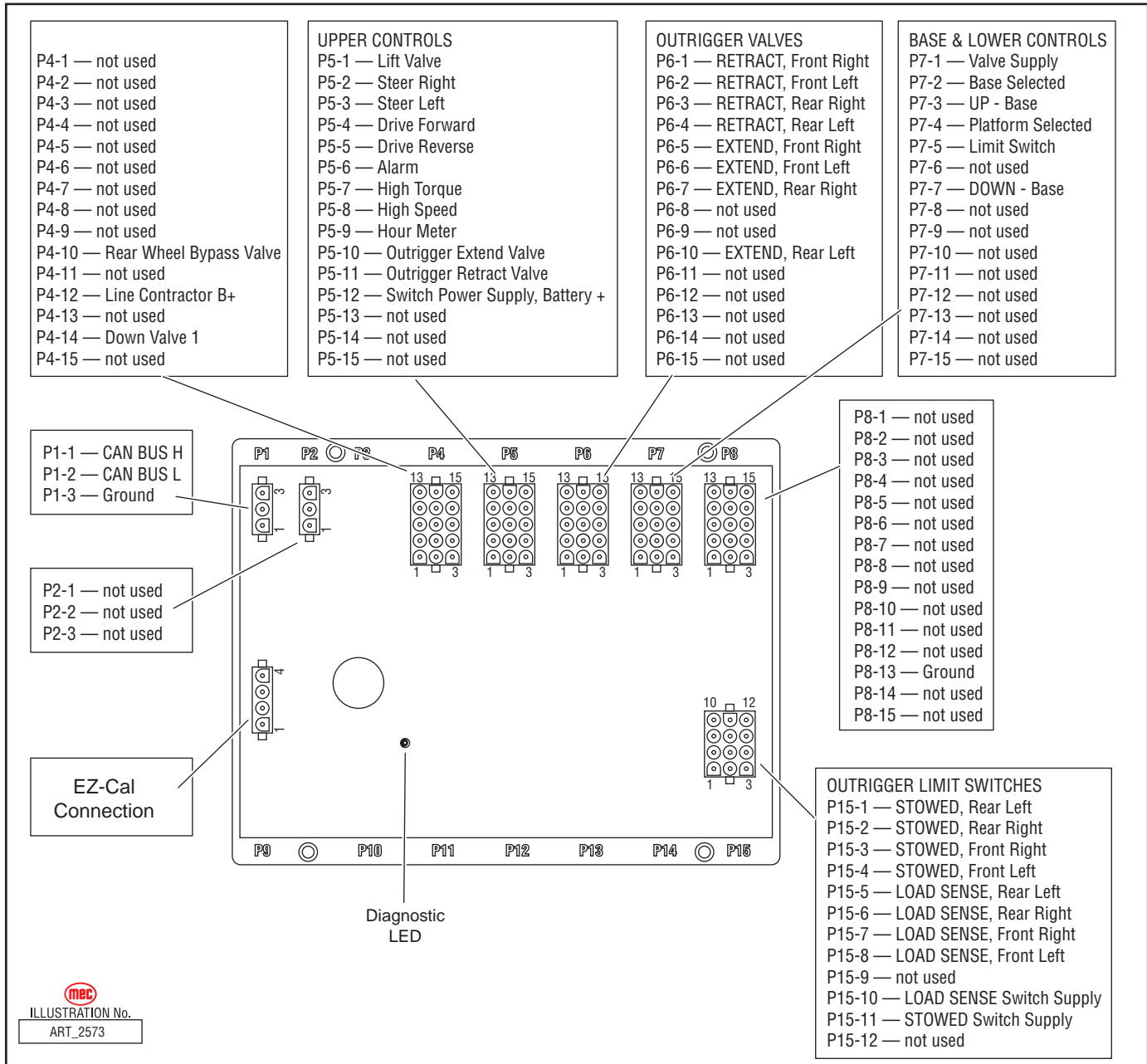

Matrix Module Controller

Located in Control Module behind lower controls.

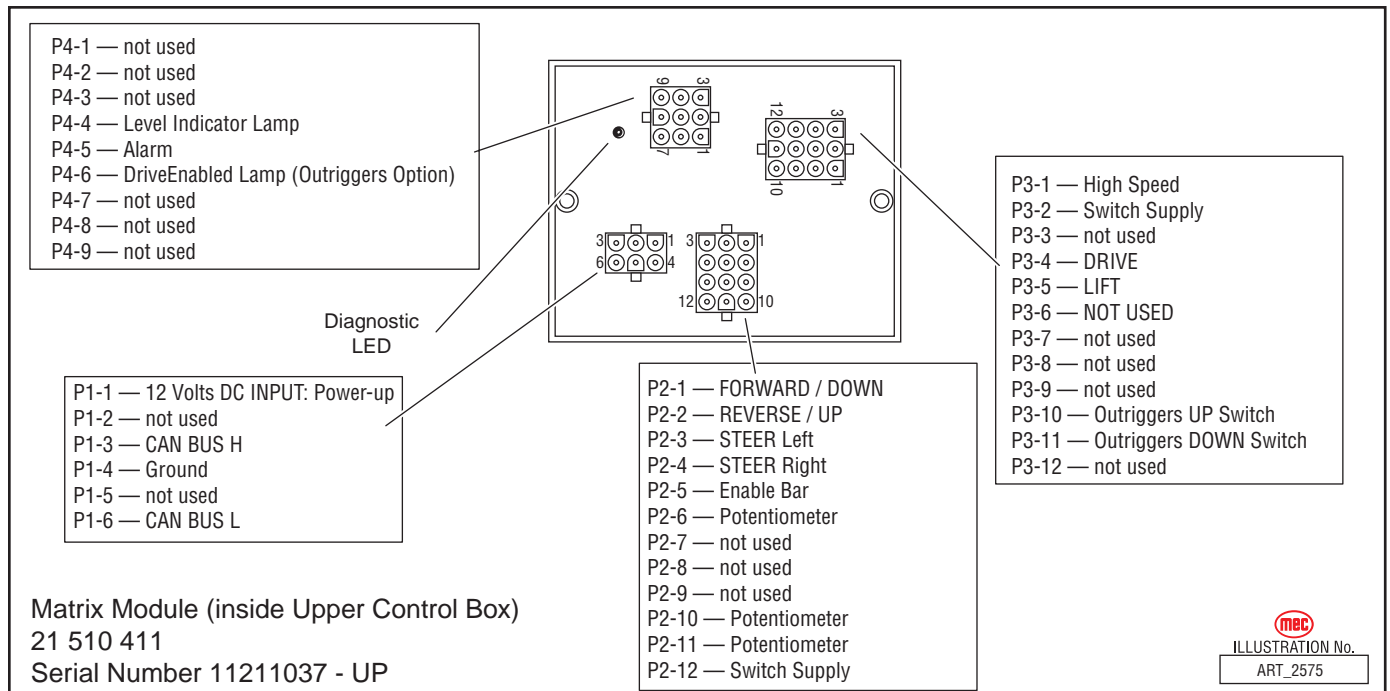
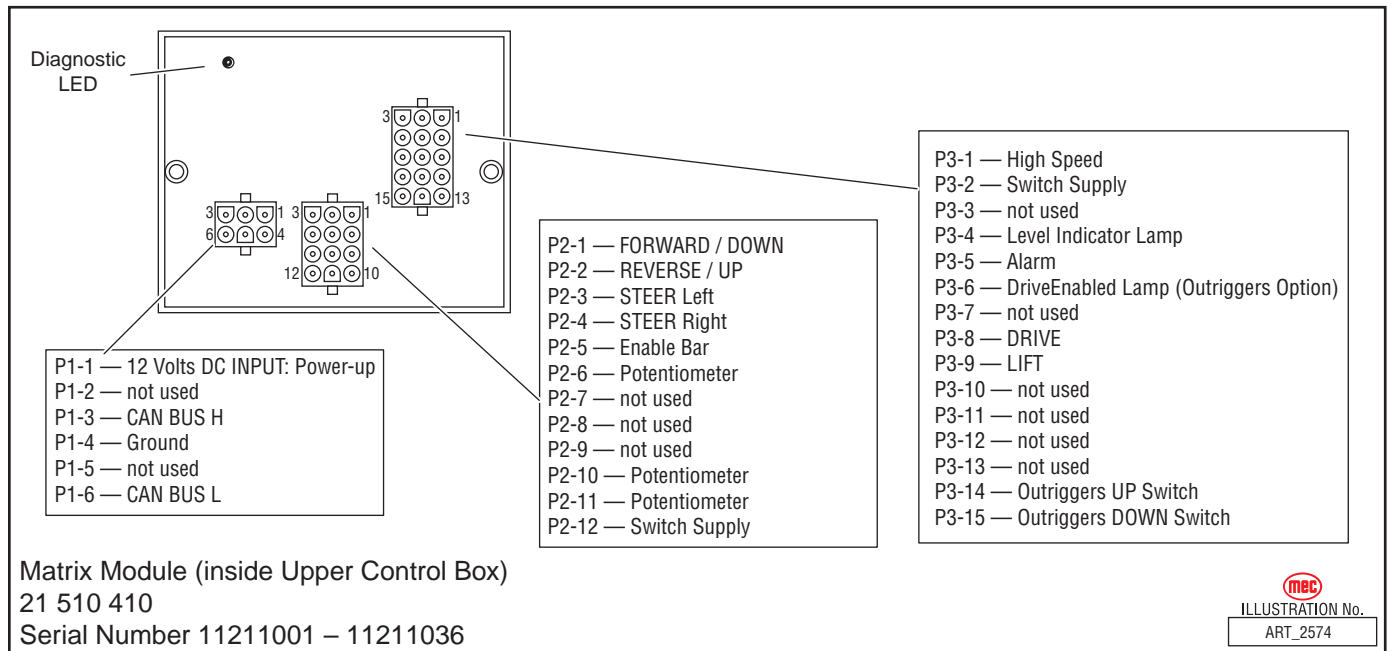



Parts Section Table of Contents

Section A: Controls	Page
Upper Controls, ANSI Models	A-3
Upper Controls, CE Models	A-5
Upper Control Box Cover Assembly	A-7
Upper Control Joystick	A-9
Lower Controls	A-11
Section B: Platform and Rails	Page
Platform Assembly	B-3
Rollout Lock Pin Assembly	B-5
Roller Assembly	B-7
Entry Chain, ANSI Models	B-9
Swing Gate, CE Standard / ANSI Option	B-11
Control Cable / Horn Installation	B-13
Power to Platform – Airline to Platform	B-15
Lanyard Attachment: CE Standard – ANSI Option	B-17
Section C: Scissors	Page
Scissor Assembly, 3072RT: Up to Serial #11211099	C-3
Scissor Assembly, 3772RT: Up to Serial #11211099	C-5
Scissor Assembly, 3072RT: Serial #11211100 - UP	C-7
Scissor Assembly, 3072RT: Serial #11211100 - UP (continued)	C-9
Scissor Assembly, 3772RT: Serial #11211100 - UP	C-11
Scissor Assembly, 3772RT: Serial #11211100 - UP (continued)	C-13
Limit Switch Installation	C-15
Scissor Guards - 3072ES, CE Models	C-17
Scissor Guards - 3772ES, CE Models	C-19
Section D: Axles	Page
Rear Axle Assembly	D-3
Front Axle Assembly	D-5
Wheel Motor, Rear	D-7
Wheel Motor, Front	D-9



Parts Section Table of Contents

Section E: Hydraulics	Page
Main Manifold Assembly	E-3
Main Manifold Assembly (continued)	E-5
Main Relief Manifold Assembly	E-7
Manifold - Outrigger (HD Models)	E-9
Hydraulic Hoses - Axles	E-11
Hydraulic Hoses - Steering, Brake Release and Axle Return	E-13
Hydraulic Hoses - Pump and Return	E-15
Hydraulic Hoses - Outrigger (HD Models)	E-17
Lift Cylinder, 3072	E-19
Lift Cylinder, Lower, 3772	E-21
Lift Cylinder, Upper, 3772	E-23
Steering Cylinder	E-25
Outrigger Cylinder	E-27
 Section F: Base	 Page
Base Assembly	F-3
Ballast (Counterweight) Installation	F-5
Modules Installation	F-7
Control Module	F-9
Control Module (continued)	F-11
Power Module	F-13
Wire Harness	F-15
Outrigger Installation (3772ES HD)	F-17
 Section G: Decals	 Page
Decals, ANSI Models	G-3
Decals, ANSI Models (continued)	G-5
Decals, CE Models	G-9
Decals, CE Models (continued)	G-11

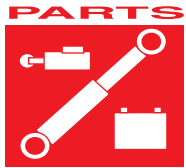

SECTION A

CONTROLS

CONTENTS	PAGE
Upper Controls, ANSI Models	A-3
Upper Controls, CE Models	A-5
Upper Control Box Cover Assembly	A-7
Upper Control Joystick	A-9
Lower Controls	A-11



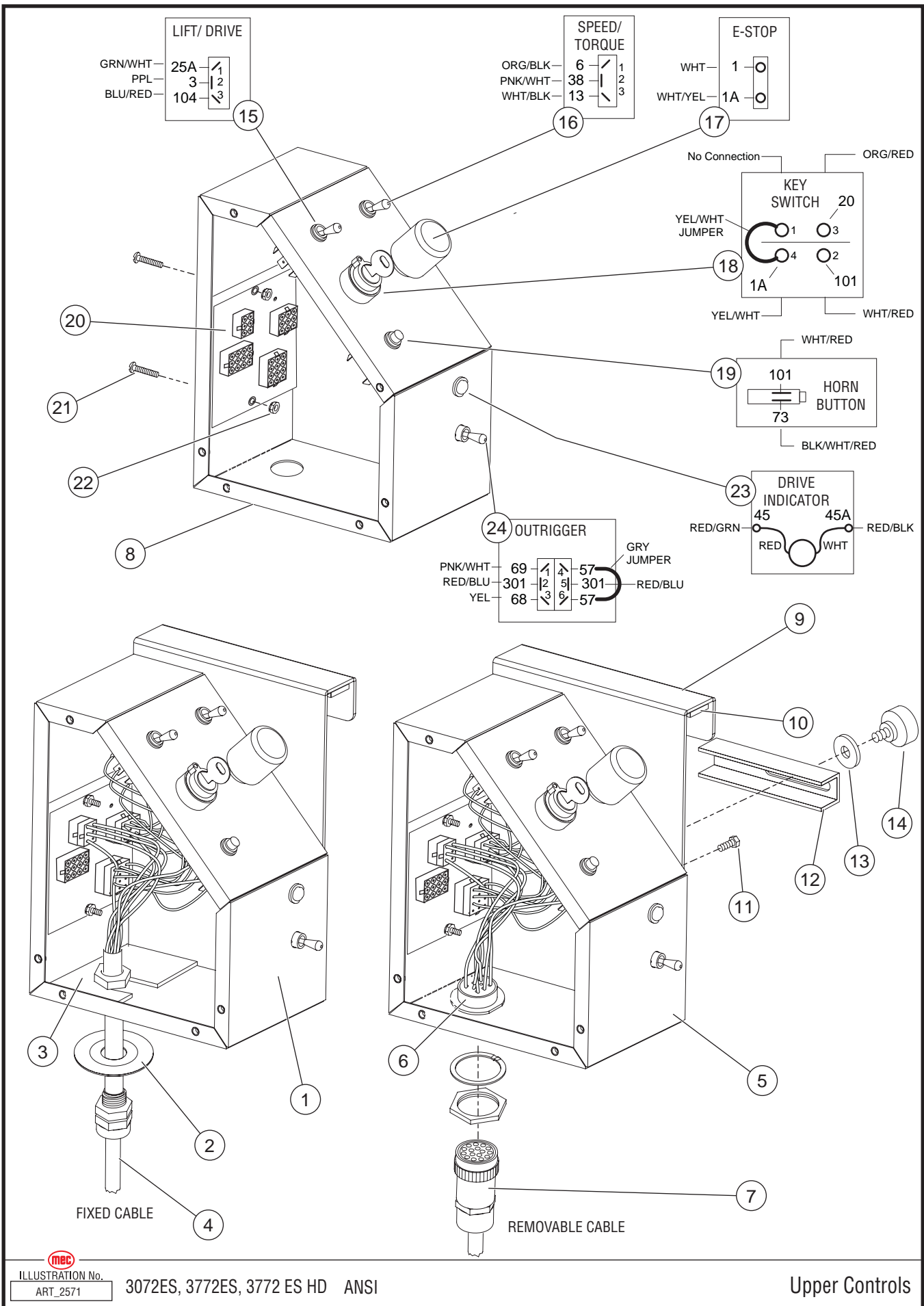

MEC
 ILLUSTRATION No.
 ART_2571

3072ES, 3772ES, 3772 ES HD ANSI

Upper Controls

Upper Controls, ANSI Models

ITEM	PART NO.	QTY	DESCRIPTION
Fixed Control Box - ANSI			
1	83059	1	with Fixed Cable, Serial #11211037 - up
2	91194	1	Strain Relief Washer
3	16120	1	Mounting Plate
4	REF	1	Cable, Fixed (see Wire Harness, Section F)
Removable Control Box - ANSI			
5	-	1	with removable Cable, Serial #11211001 - 11211100
	83051	1	with Removable Cable, Serial #11211101 - up
6	REF	1	Harness, Removable (see Wire Harness, Section F)
7	REF	1	Cable, Removable (see Wire Harness, Section F)
Fixed and Removable Control Box - ANSI			
8	16242	1	Weldment, Control Box
9	13865	1	Bracket, Control Box Holder
10	6350	0.5 FT	Tape, Foam
11	HDW5724	1	Screw, 5/16-18
12	13864	1	Bracket, Control Box Holder
13	HDW8294	1	Washer, Flat
14	8826	1	Thumb Screw, 5/16-18, Flower
15	6234	1	Switch, Toggle, Lift/Drive
16	6905	1	Switch, Toggle, Speed/Torque
17	7800	1	Switch, Emergency Stop
18	91159	1	Keyswitch
	8082	1	Contact Block, NO
	8083	1	Contact Block, NC
19	8044	1	Switch, Horn Button (Option)
20	91663	1	Matrix Module, Up to Serial # 11211036
	91762	1	Matrix Module Serial # 11211037 - UP
21	HDW90879	2	Screw
22	HDW90803	2	Nut
23	90789	1	LED, Green, Drive Enabled (HD Models)
24	5694	1	Switch, Toggle (HD Models)

• as req: as required

• INCL: Included with assembly

• NS: Not a Stock item

• REF: Reference only



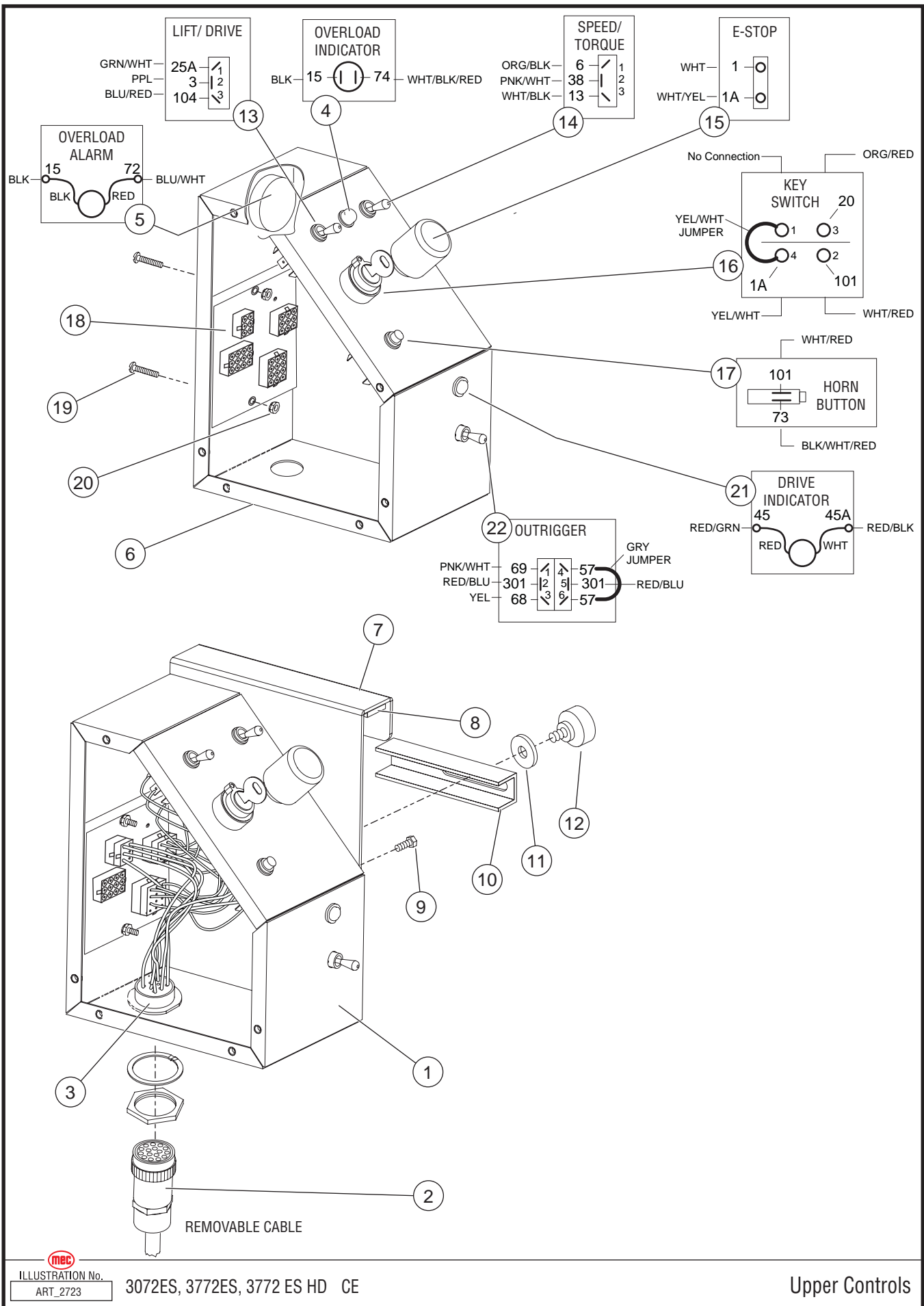

mecc
 ILLUSTRATION No.
 ART_2723

3072ES, 3772ES, 3772 ES HD CE

Upper Controls

Upper Controls, CE Models

ITEM	PART NO.	QTY	DESCRIPTION
1	90873	1	With Removable Cable
2	REF	1	Cable, Removable(See Wire Harness, Section F)
3	REF	1	Harness, Removable(See Wire Harness, Section F)
4	9183	1	Lens, Red, Overload Indicator
	9188	1	Light, Bayonet, 14 Volt
	9179	1	Socket, Indicator Light
5	7553	1	Alarm, Overload Warning
6	16242	1	Weldment, Control Box
7	13865	1	Bracket, Control Box Holder
8	6350	0.5 FT	Tape, Foam
9	HDW5724	1	Screw, 5/16-18
10	13864	1	Bracket, Control Box Holder
11	HDW8294	1	Washer, Flat
12	8826	1	Thumb Screw, 5/16-18, Flower
13	6234	1	Switch, Toggle, Lift/Drive
14	6905	1	Switch, Toggle, Speed/Torque
15	7800	1	Switch, Emergency Stop
16	91159	1	Keyswitch
	8082	1	Contact Block, NO
	8083	1	Contact Block, Nc
17	8044	1	Switch, Horn Button (Option)
18	91663	1	Matrix Module, Up to Serial # 11211036
	91762	1	Matrix Module Serial # 11211037 - UP
19	HDW90879	2	Screw
20	HDW90803	2	Nut
21	90789	1	LED, Green, Drive Enabled (HD Models)
22	5694	1	Switch, Toggle (HD Models)

• as req: as required

• INCL: Included with assembly

• NS: Not a Stock item

• REF: Reference only



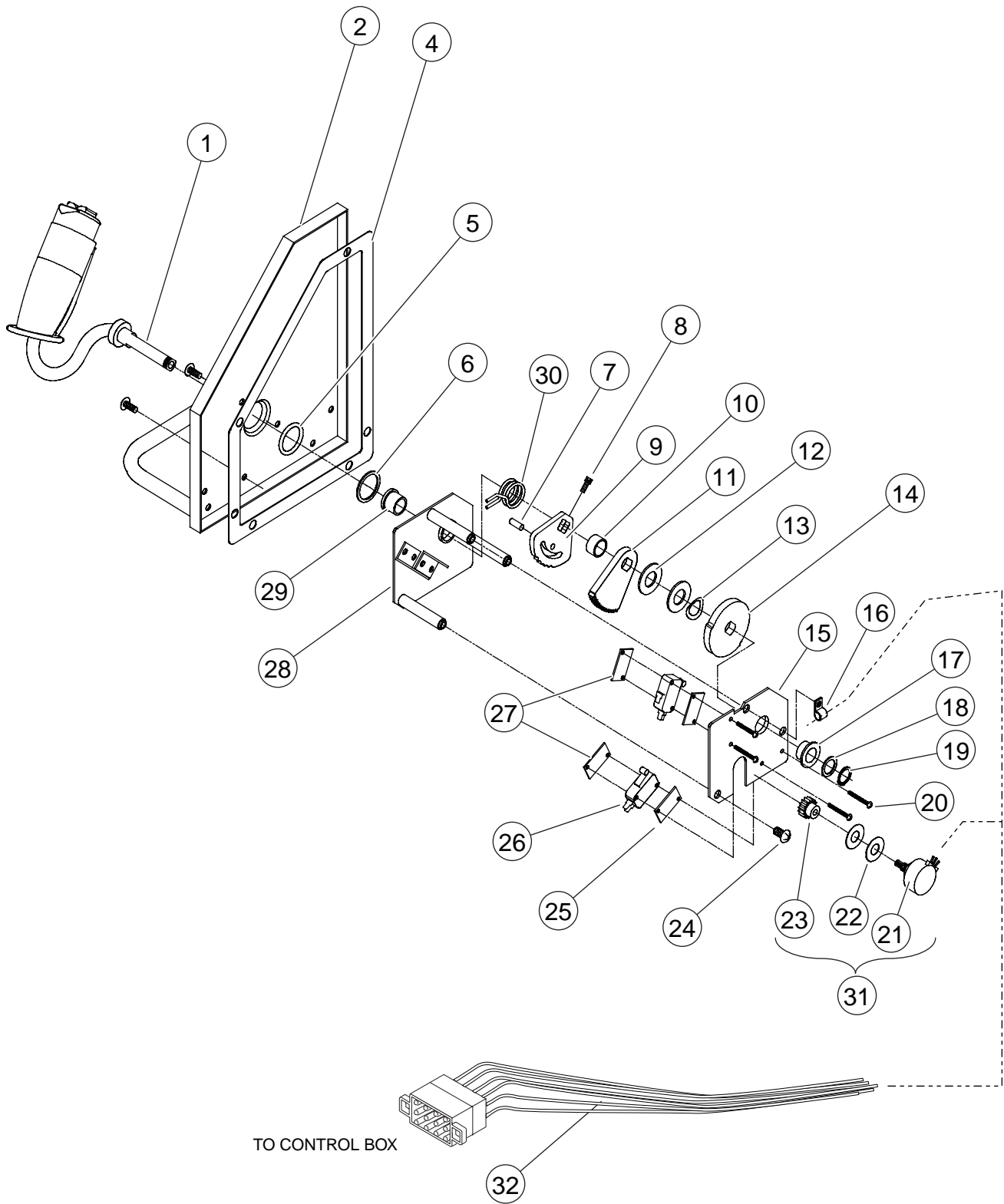

TO CONTROL BOX

32

Upper Control Box Cover Assembly

ITEM	PART NO.	QTY	DESCRIPTION
-	13868	-	Control Box Cover Assembly
1	13647	1	Control Arm
2	3772	1	Cover
3	-	-	-
4	7875	1	Gasket
5	7882	1	O-ring, 7/8" Id X 1 1/8" Od
6	HDW3768	1	Washer, Flat
7	1008348	1	Pin, Hold Down
8	HDW7887	1	Screw, #6-32, 1/2" Lg
9	13502	1	Bracket, Centering
10	3763	1	Spacer, Step
11	13402	1	Gear, Large
12	HDW8531	2	Washer, Flat
13	HDW7881	1	Washer, Bevel
14	3782	1	Cam. Directional
15	13403	1	Plate, Bottom
16	6917	1	Clamp, Cable 1/4"
17	7818	1	Bearing, Bronze, Flanged
18	HDW3771	1	Washer, Flat
19	5736	1	Ring, Retaining, 1/2"
20	HDW8399	4	Screw, #4 - 40, 5/8" Lg
21	8383	1	Potentiometer
22	HDW8567	2	Washer, Flat
23	8389	1	Gear, Spur
24	HDW7888	12	Screw, #10 - 32, 1/2" Lg
25	3764	2	Plate, Spacer
26	8696	2	Switch, Limit, Micro V7
27	3765	2	Plate, Strap
28	3766	1	Plate, Top
29	7819	1	Bearing, Bronze, Flanged
30	8435	1	Spring, Joystick, Centering
31	13527	1	Potentiometer Assembly (Includes 21, 22, & 23)
32	REF	1	Wire Harness (see Wire Harness, Section F)

• as req: as required

• INCL: Included with assembly

• NS: Not a Stock item

• REF: Reference only



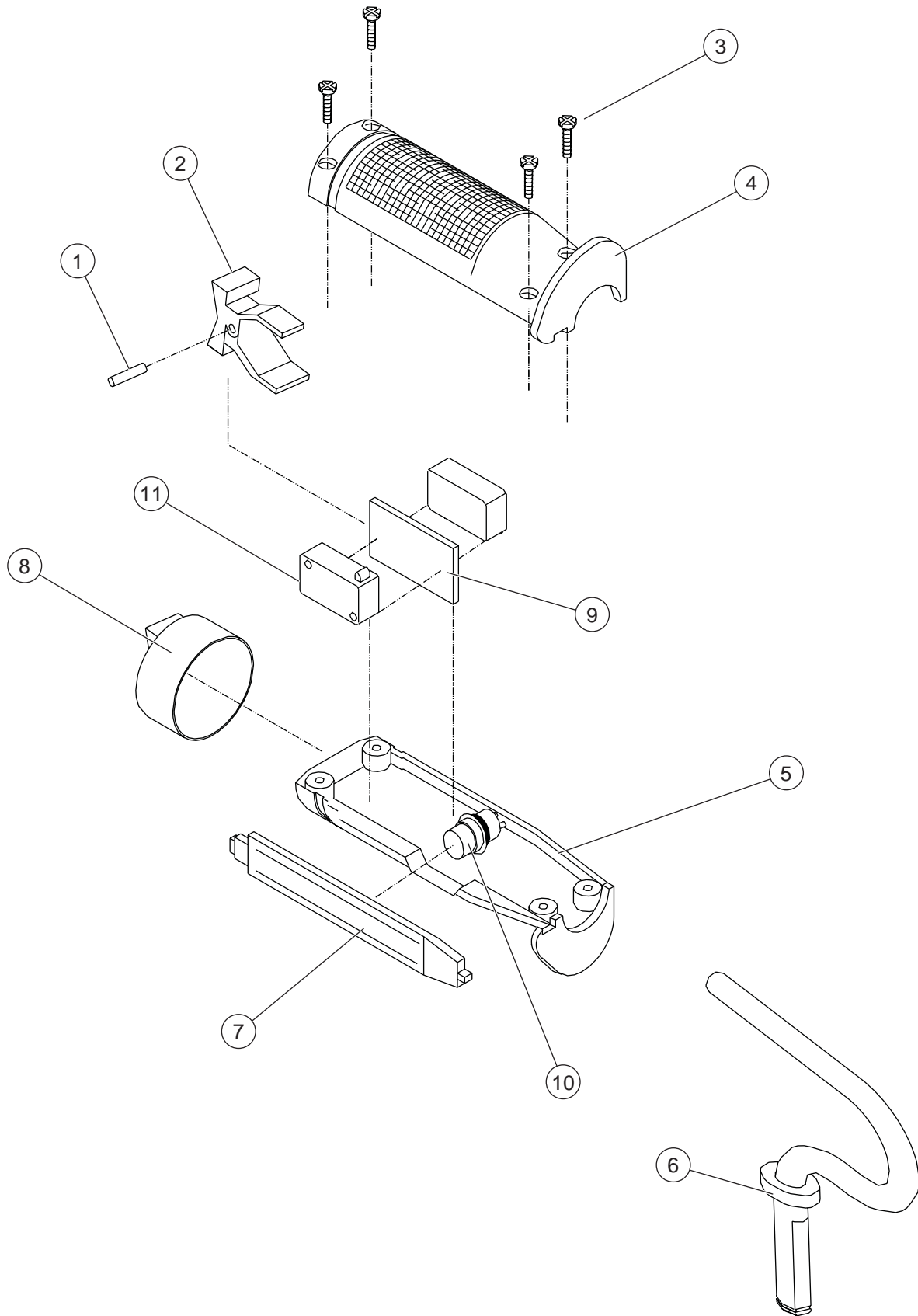

ILLUSTRATION No.
ART_2221 R1

Reference: ART_188

Control Arm (Joystick)

Upper Control Joystick

ITEM	PART NO.	QTY	DESCRIPTION
-		-	CONTROL ARM ASSEMBLY, JOYSTICK
1	8750	1	PIN (SERVICE ONLY)
2	8453	1	SWITCH ACTUATOR (SERVICE ONLY)
3	HDW8455	4	SCREW, 6-1/2" LG (SERVICE ONLY)
4	8752	1	GRIP-TOP HALF (SERVICE ONLY)
5	8751	1	GRIP-BOTTOM HALF (SERVICE ONLY)
6	13638	1	CONTROL ARM WITHOUT WIRE
7	8748	1	TRIGGER (SERVICE ONLY)
8	8456	1	ROCKER BOOT (SERVICE ONLY)
-	8761	-	SWITCH ASSEMBLY (NOT SHOWN)
9	8447	1	SWITCH SEPARATOR(SERVICE ONLY)
10	8753	1	MOTION SWITCH, ON-OFF (SERVICE ONLY)
11	8448	2	SWITCH (SERVICE ONLY)
-	7476	5	AMP PINS
-	8089	1 FT	WIRE, BLK 18GA 300 V
-	7777	2	TERMINAL, PUSH ON, 3/16"
-	8630	1	HANDLE, GRIP

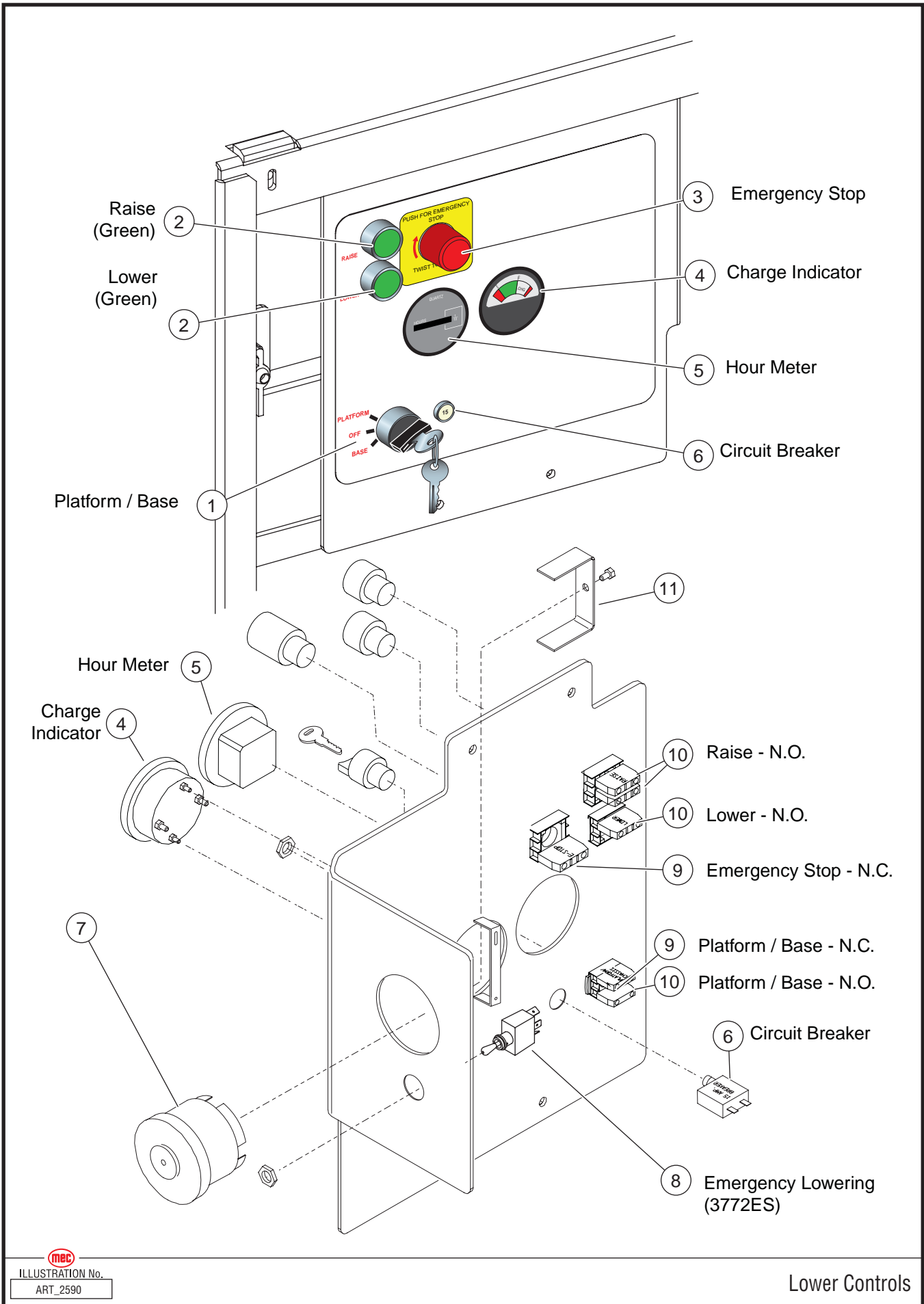



 ILLUSTRATION No.
 ART_2590

Lower Controls

Lower Controls

ITEM	PART NO.	QTY	DESCRIPTION
1	9549	1	Switch, 3-position, Keyed
2	91533	2	Switch, Button, Green
3	91534	1	Switch, Button, Red
4	91744	1	Charge Indicator
5	7909	1	Hour Meter
6	7235	1	Circuit Breaker, 15 Amp
7	91711	1	Alarm, 107dB
8	7423	1	Switch, Toggle, 1 Pole 2 Pos
9	91538	2	Block, Contact, N.C.
10	91537	4	Block, Contact, N.O.
11	17082	1	Bracket, Alarm Mount

• as req: as required

• INCL: Included with assembly

• NS: Not a Stock item

• REF: Reference only



NOTES:



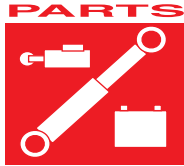

SECTION B

PLATFORM AND RAILS

CONTENTS	PAGE
Platform Assembly	B-3
Rollout Lock Pin Assembly	B-5
Roller Assembly	B-7
Entry Chain, ANSI Models	B-9
Swing Gate, CE Standard / ANSI Option	B-11
Control Cable / Horn Installation	B-13
Power to Platform – Airline to Platform	B-15
Lanyard Attachment: CE Standard – ANSI Option	B-17



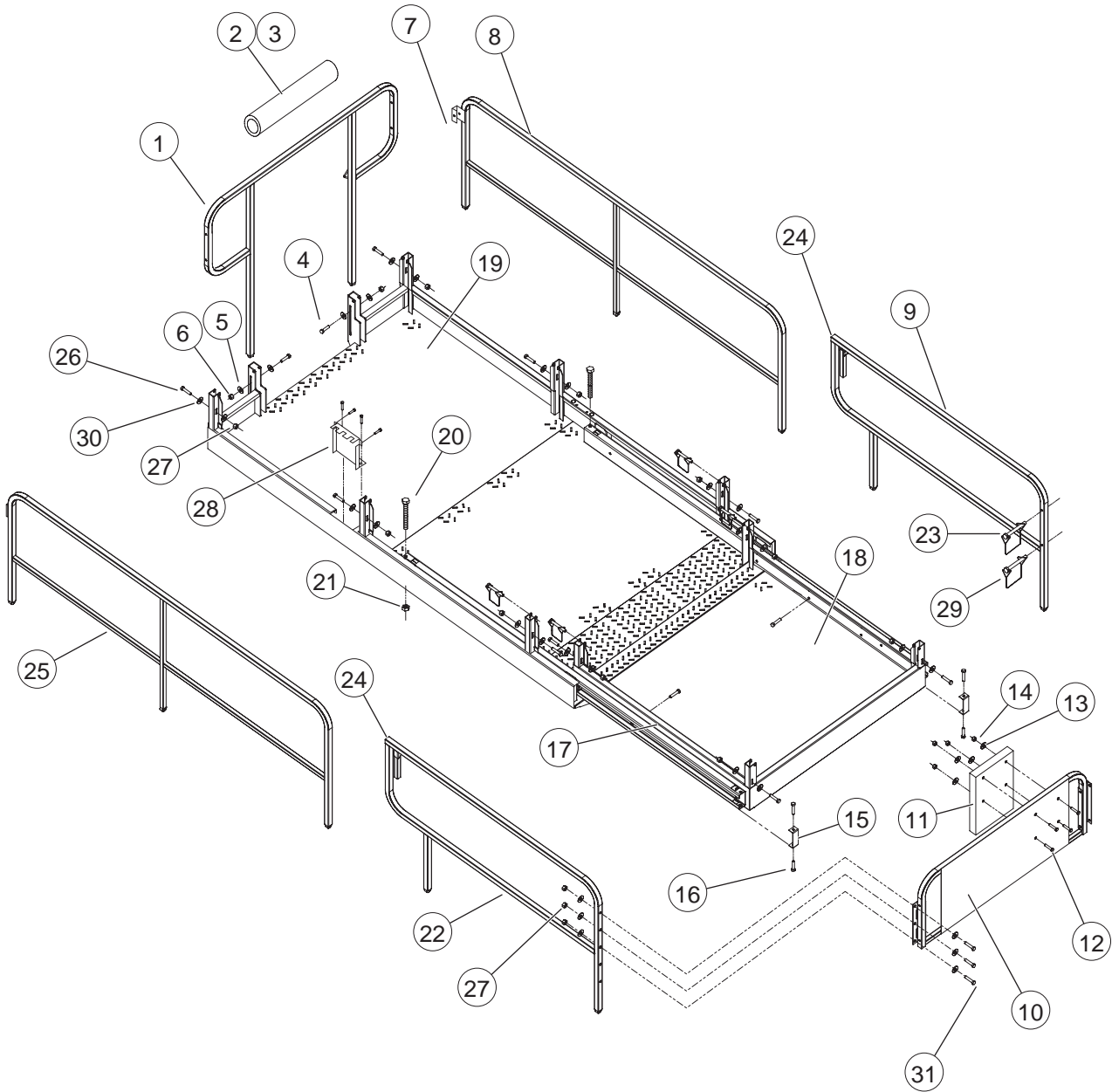

Platform Assembly

ITEM	PART NO.	QTY	DESCRIPTION
1	16222	1	Rear Rail Weldment
2	7805	1	Padding, Rail (optional)
3	7048	1	Cover, Rail Padding (optional)
4	HDW7119	2	Screw, 5/16" - 18, 2 1/4" LG, GR 5
5	HDW5217	4	Flat Washer, .343 ID x .688 OD x .063 THK
6	HDW8304	6	Nut, 5/16" - 18
7	HDW7593	6	Pin, Wire Lock, Square, 3/8" x 2 1/4" LG
8	16176	1	Side Rail Weldment, LH
9	14301	1	Side Rail Weldment - EXTENSION
10	16177	1	Front Rail Weldment
11	8909	1	Manual Enclosure
12	HDW5723	8	Screw, 1/4" - 20, 1/2" LG
13	HDW8294	4	Flat Washer, .328 ID x 1.000 OD x .100 THK
14	HDW8267	4	Nut, 1/4" - 20
15	14415	2	Bracket, Extension Stop
16	HDW5724	20	Screw, 5/16" - 18, 3/4" LG, GR 5
17	14152	2	Channel, Extension
18	16202	1	Extension Platform Weldment
19	16196	1	Main Platform Weldment
20	HDW8856	2	Screw, 1/2"-13, 5" LG
21	HDW8457	2	Nut, 1/2" - 13
22	14313	1	Right Side Rail Weldment - Extension
23	HDW8974	1	Pin, Wire Lock, Square, 3/8" x 3" LG
24	6823	2	Cap Plug, 1 1/4"
25	16224	1	Side Rail Weldment, RH
26	HDW8279	10	Screw, 3/8-16, 2 1/2" LG
27	HDW8268	10	Nut, 3/8-16
28	20552	1	Cover, Platform Cord (Not Shown)
29	91284	1	Pin Hitch 3/8" x 4
30	HDW5355	20	Washer, Flat, .438 IDx1.00 ODx.078 THK
31	HDW6434	3	Screw, 3/8-16x2" LG

• as req: as required

• INCL: Included with assembly

• NS: Not a Stock item

• REF: Reference only



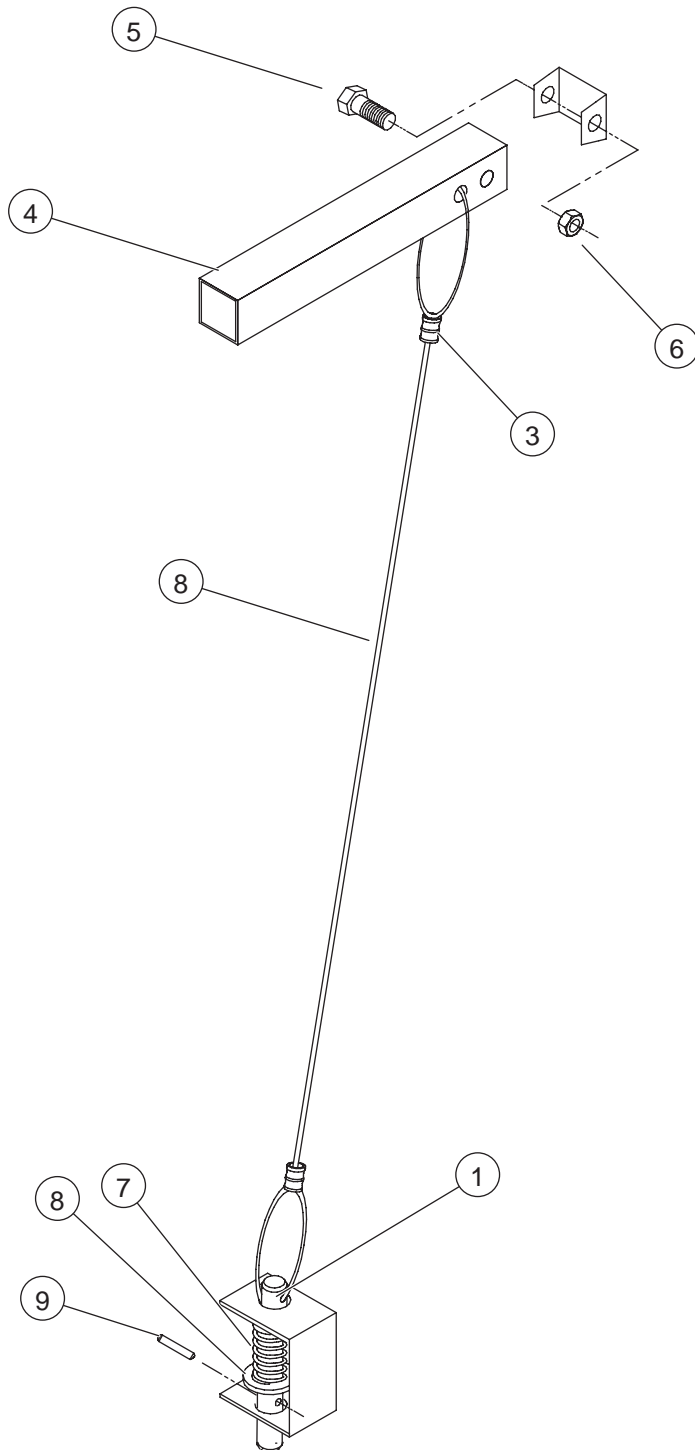

MEC
 ILLUSTRATION No.
 ART_2133

Roll-out Deck Lock Pin Assembly

Rollout Lock Pin Assembly

ITEM	PART NO.	QTY	DESCRIPTION
1	13737	1	Pin, Extension Lock
2	7184	3.7 FT	Cable, Coated And Rolled
3	8814	2	Sleeve, Aluminum Oval
4	14344	1	Handle
5	HDW8303	1	Screw, 5/16" - 18, 2" LG
6	HDW8304	1	Locknut, 5/16" - 18
7	7408	1	Spring, Deck Lock
8	HDW7031	1	Washer, Flat, 1/2" ID 7/8" OD
9	HDW8513	1	Pin, Spring, 1/8" DIA. 3/4" LG

• as req: as required

• INCL: Included with assembly

• NS: Not a Stock item

• REF: Reference only



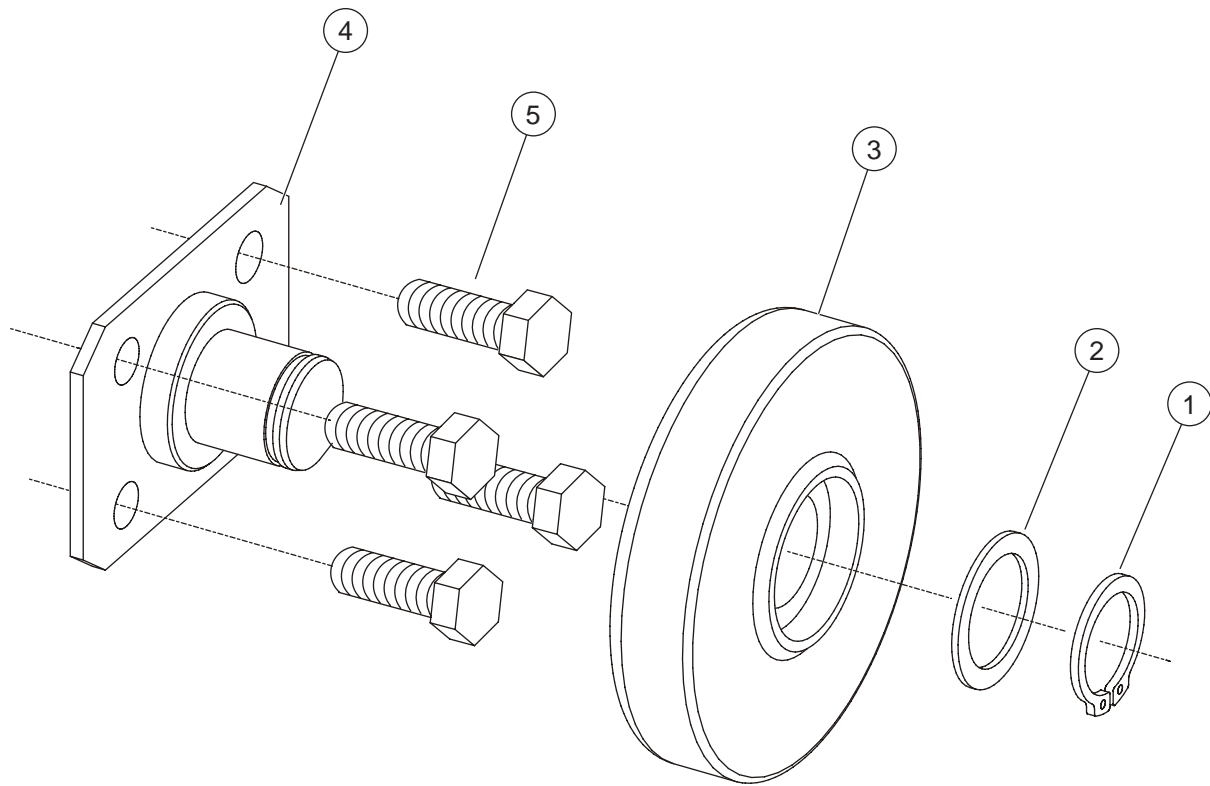

ILLUSTRATION No.
ART_2095

Reference: ART_687

Roll-out Deck Roller

Roller Assembly

ITEM	PART NO.	QTY	DESCRIPTION
1	5918	1	Retaining Ring, Heavy Duty 1IN
2	HDW8370	1	Washer, Flat, 1.015 ID x 1.375 OD x .062 THK
3	13230	1	Roller
4	14062	1	Roller Plate Weldment
5	HDW5724	4	Screw, 5/16" - 18, 3/4" LG

• as req: as required

• INCL: Included with assembly

• NS: Not a Stock item

• REF: Reference only



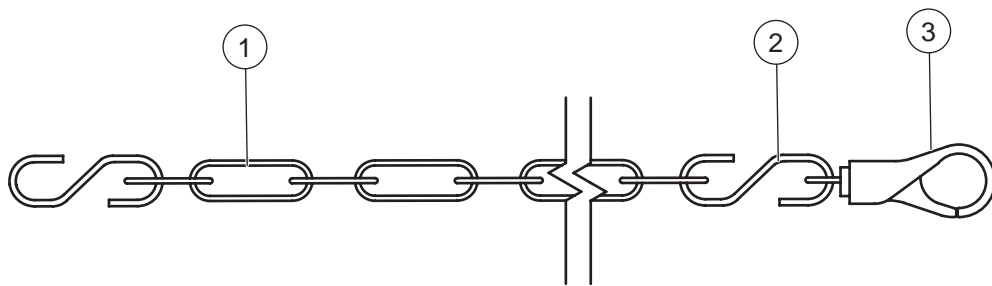

ILLUSTRATION No.
ART_2096

Reference: ART_13850

Entry Chain

Entry Chain, ANSI Models

ITEM	PART NO.	QTY	DESCRIPTION
1	13846	1	Chain
2	5239	2	S-hook, Connecting Link
3	8781	1	Snap, Chain Link

• as req: as required

• INCL: Included with assembly

• NS: Not a Stock item

• REF: Reference only



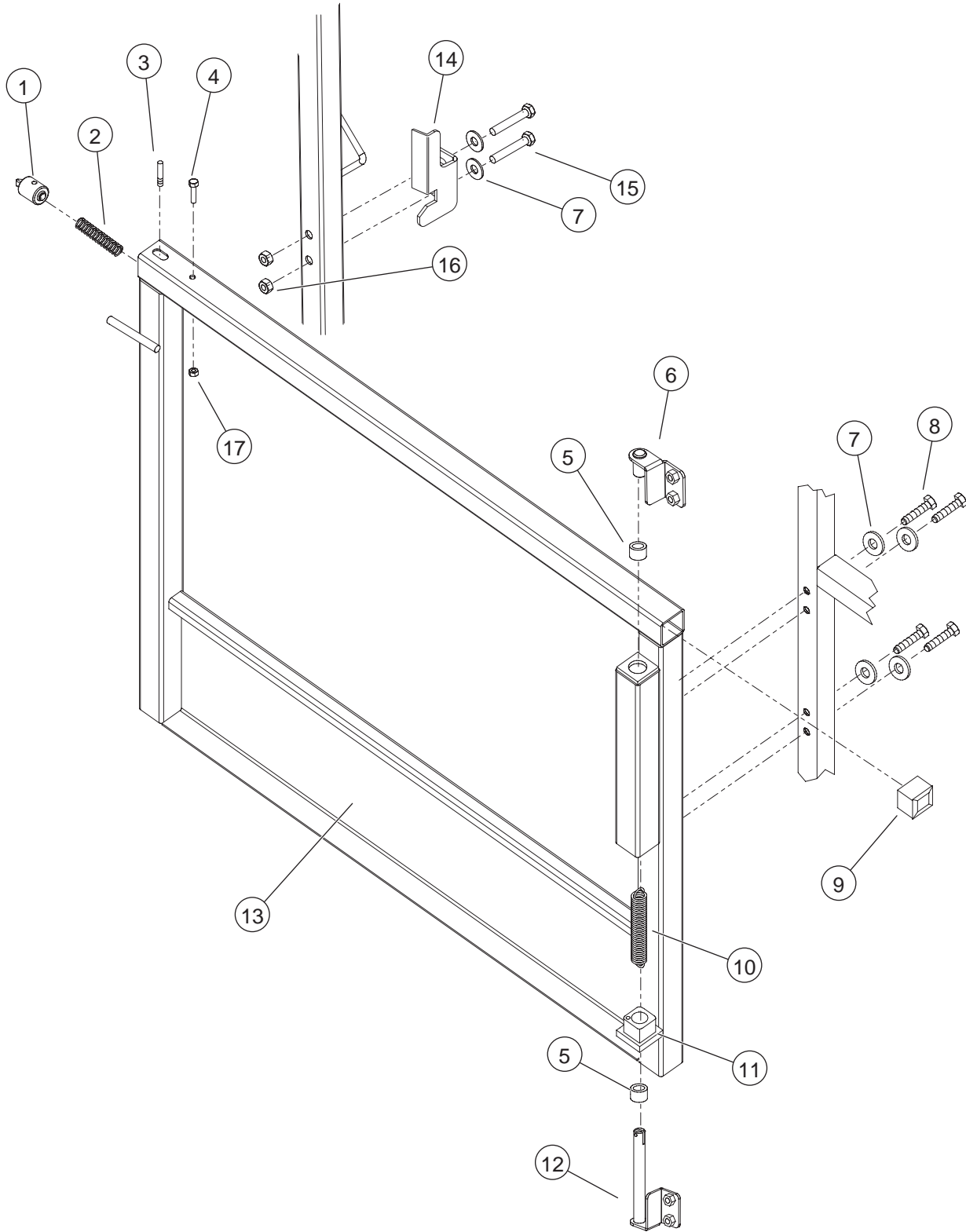

ILLUSTRATION No.
ART_2097

Gate

Swing Gate, CE Standard / ANSI Option

ITEM	PART NO.	QTY	DESCRIPTION
1	40003	1	Latch Pin, Rear Gate
2	7055	1	Spring, Latch, .480 DIA. OD x 1.5" LG
3	40006	1	Rod, Latch Lever, Rear Gate
4	HDW6434	1	Screw, 3/8-16 x 2" LG
5	8187	2	Bearing, Nyliner, 5/8" ID x 5/8" LG
6	40014	1	Mounting Bracket, Upper
7	HDW8294	6	Washer, .328" ID x 1" OD x .100" THK
8	HDW8486	4	Screw, 5/16" - 18, 1 7/8" LG, GR 5
9	6823	1	Cap Plug, 1 1/4" Square
10	8300	1	Spring, Torsion, 1" DIA. OD x 4" LG
11	13272	1	Block, Pivot, Rear Gate
12	40015	1	Mounting Bracket, Lower
13	40017	1	Swing Gate Weldment
14	30814	1	Strike Plate
15	HDW8303	2	Screw, 5/6"-18, 2" LG, GR 5
16	HDW7120	2	Nut, 5/16"-18, GR 5
17	HDW8268	1	Nut, 3/8-16

• as req: as required

• INCL: Included with assembly

• NS: Not a Stock item

• REF: Reference only



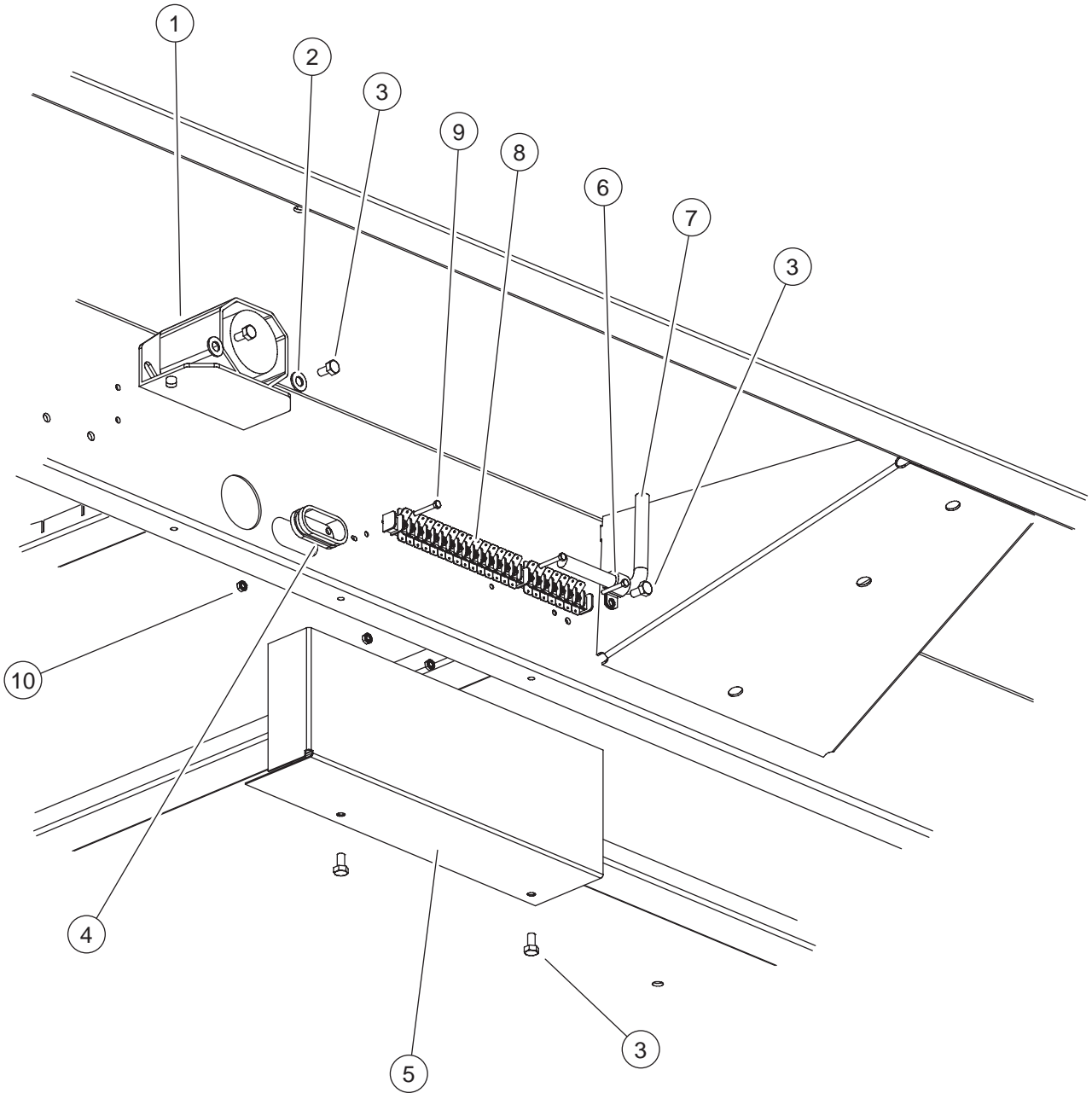

ILLUSTRATION No.
ART_2591 R1

Control Cable Installation

Control Cable / Horn Installation

ITEM	PART NO.	QTY	DESCRIPTION
1	9716	1	HORN, 12-48V (option)
2	HDW5217	2	WASHER, FLAT, .343 ID x .688 OD x .063 THK
3	HDW6455	5	SCREW, ¼"-20, ½" LG, GR 5
4	5863	2	GROMMET, 1.5 ID x 1.75 OD x .187 THK
5	14604	1	COVER, TERMINAL STRIP
6	6964	1	CLAMP, CABLE, 1" DIA.
7	REF	-	CABLE, UPPER CONTROL
Items 8 – 10 installed on units Up to Serial # 11211141. Replace with modular harness (ref page F-15)			
8	6947	1	TERMINAL STRIP
9	HDW5363	3	SCREW, #6-32, 1" LG, GR 5
10	HDW5364	5	NUT, KEPS, #6-32 , GR 5

• as req: as required

• INCL: Included with assembly

• NS: Not a Stock item

• REF: Reference only



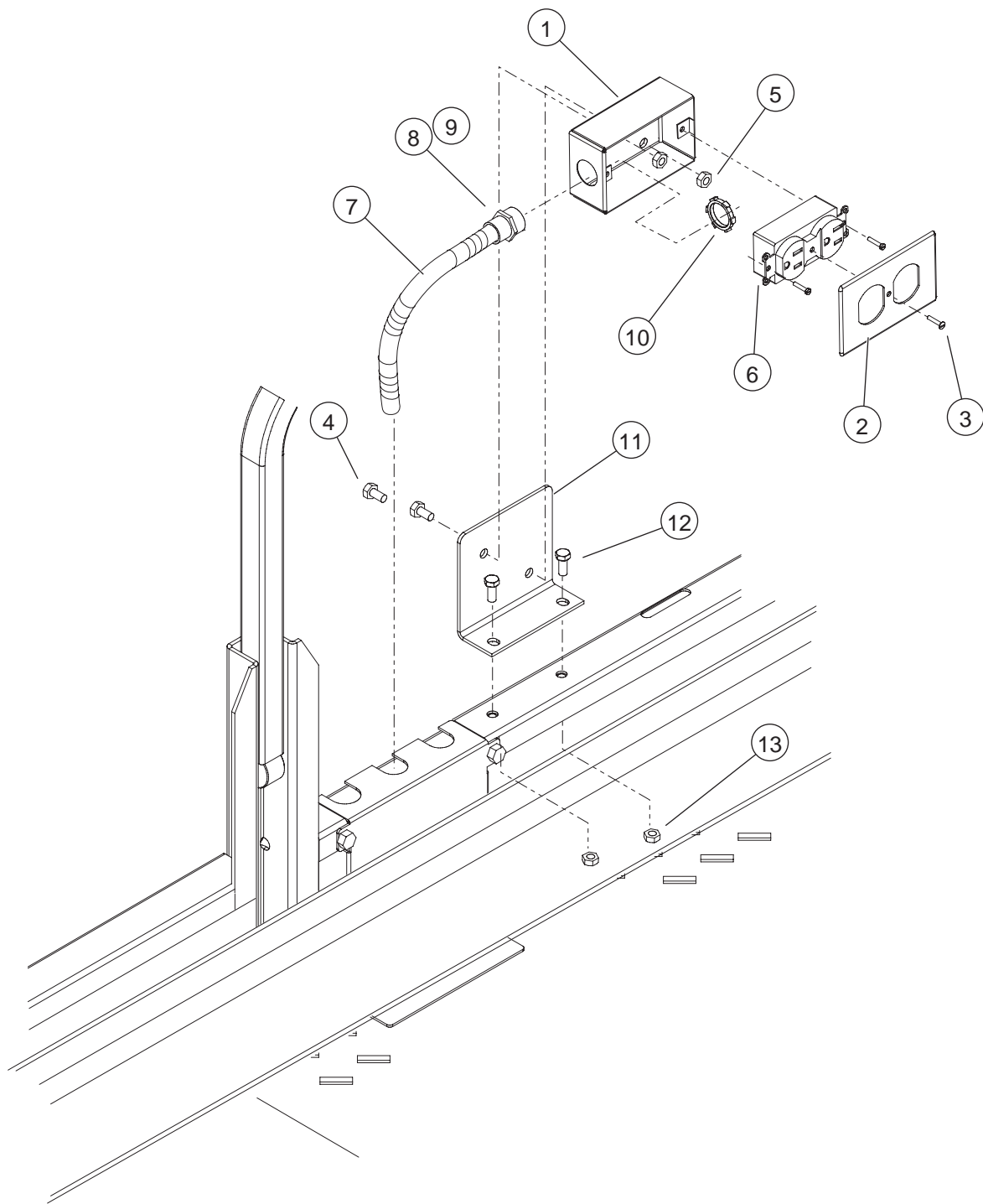

ILLUSTRATION No.
ART_2099

Power to Platform

Power to Platform – Airline to Platform

ITEM	PART NO.	QTY	DESCRIPTION
Power to Platform			
1	90827	1	Box, Receptacle
2	90828	1	Duplex Receptacle Cover
3	HDW5636	1	Screw #6 - 32 x 0.25"
4	HDW6455	2	Screw, 1/4" - 20, 1/2" LG
5	HDW8267	2	LOCKNUT 1/4" - 20
6	5381	1	Receptacle, Duplex
7	8208	1	Conduit, 3/8" Flexible
8	8209	1	Ferrule, 3/8"
9	8479	1	Bushing, 3/4" ID
10	8833	1	Connector, Outlet Box 3/8" Conduit
11	16221	1	Bracket
12	HDW5724	2	Screw, 5/16-18 x 3/4"
13	HDW8304	2	Nut, 5/16-18
-	HDW8501	2	Wire, 14 GA
-	7617	50 FT	3072ES: Wire, 14 GA
-		58 FT	3772ES: Wire, 14 GA
	HDW5217	2	Flat Washer 11/32" ID
Airline to Platform (not shown)			
-	5351	1	Cable Tie
-	91399	49 FT	3072ES: Hose, 3/8" Airline
-		57 FT	3772ES: Hose, 3/8" Airline
-	8559	2	Clamp, Hose
-	HDW91500	2	Fitting, 1/4" Male, Male Hose Barb
-	5882	2	Cable Clamp

• as req: as required

• INCL: Included with assembly

• NS: Not a Stock item

• REF: Reference only



WARNING

- LANYARD ANCHORAGE POINTS ARE RECOMMENDED FOR WORK POSITIONING RESTRAINTS ONLY.

USE OF FALL ARREST SYSTEMS ATTACHED TO ANCHORAGE POINTS ON MOBILE EQUIPMENT MAY CAUSE MACHINE TO TIP, RESULTING IN SERIOUS INJURY OR DEATH.

8606

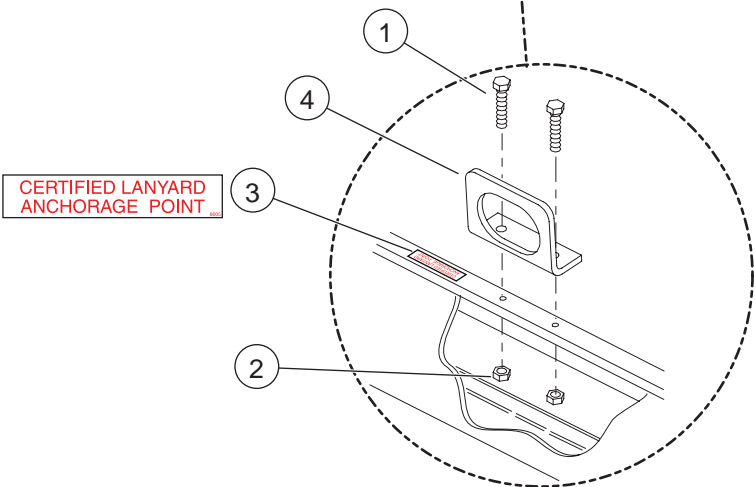
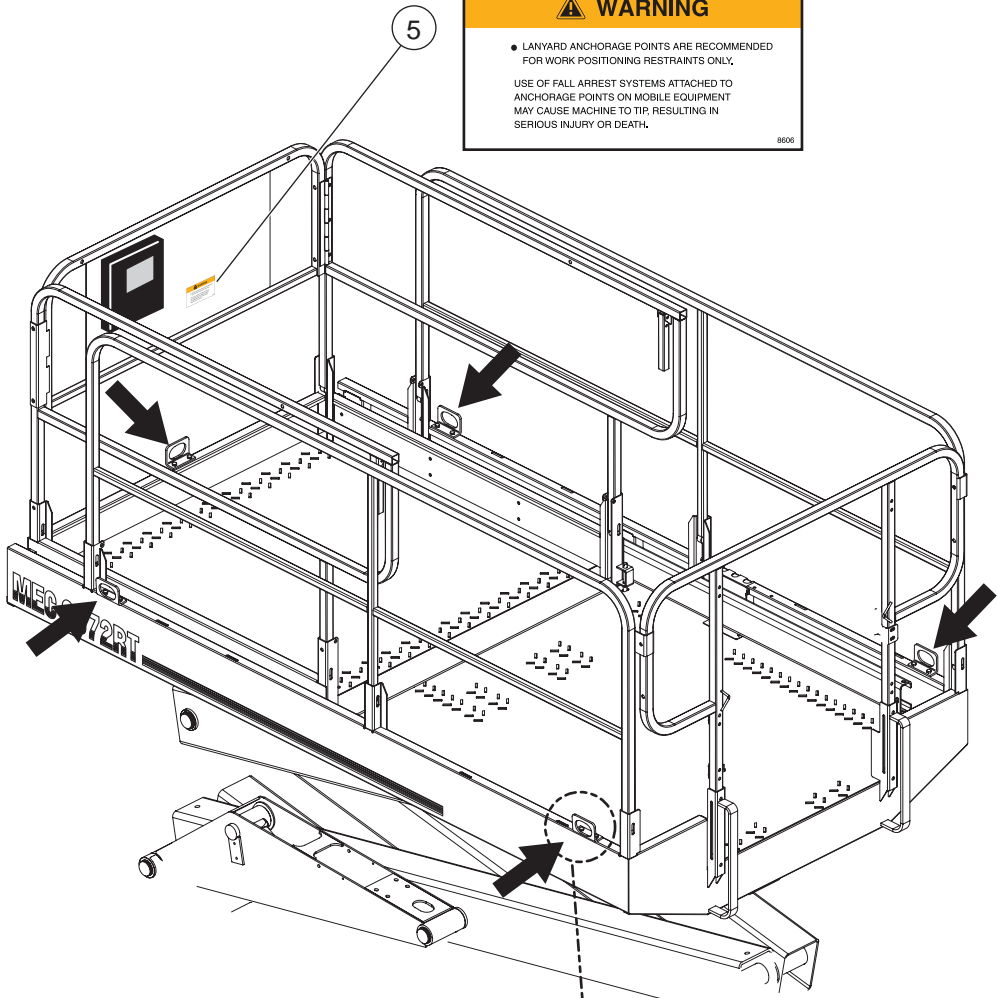

Lanyard Attachment: CE Standard – ANSI Option

ITEM	PART NO.	QTY	DESCRIPTION
–	14583	–	Lanyard Attachment Kit
1	HDW6433	10	Screw, 3/8" - 16, 1" LG, GR 5
2	HDW8268	10	Nut, 3/8" - 16, GR 5
3	8605	5	Decal, Lanyard Attach Point
4	3923	5	Bracket, Attach Point
5	8606	1	Decal, Warning, Pos Restraints

• as req: as required

• INCL: Included with assembly

• NS: Not a Stock item

• REF: Reference only



NOTES:



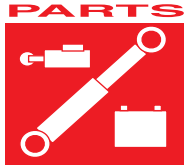

SECTION C

SCISSORS

CONTENTS	PAGE
Scissor Assembly, 3072RT: Up to Serial #11211099	C-3
Scissor Assembly, 3772RT: Up to Serial #11211099	C-5
Scissor Assembly, 3072RT: Serial #11211100 - UP	C-7
Scissor Assembly, 3072RT: Serial #11211100 - UP (continued)	C-9
Scissor Assembly, 3772RT: Serial #11211100 - UP	C-11
Scissor Assembly, 3772RT: Serial #11211100 - UP (continued)	C-13
Limit Switch Installation	C-15
Scissor Guards - 3072ES, CE Models	C-17
Scissor Guards - 3772ES, CE Models	C-19



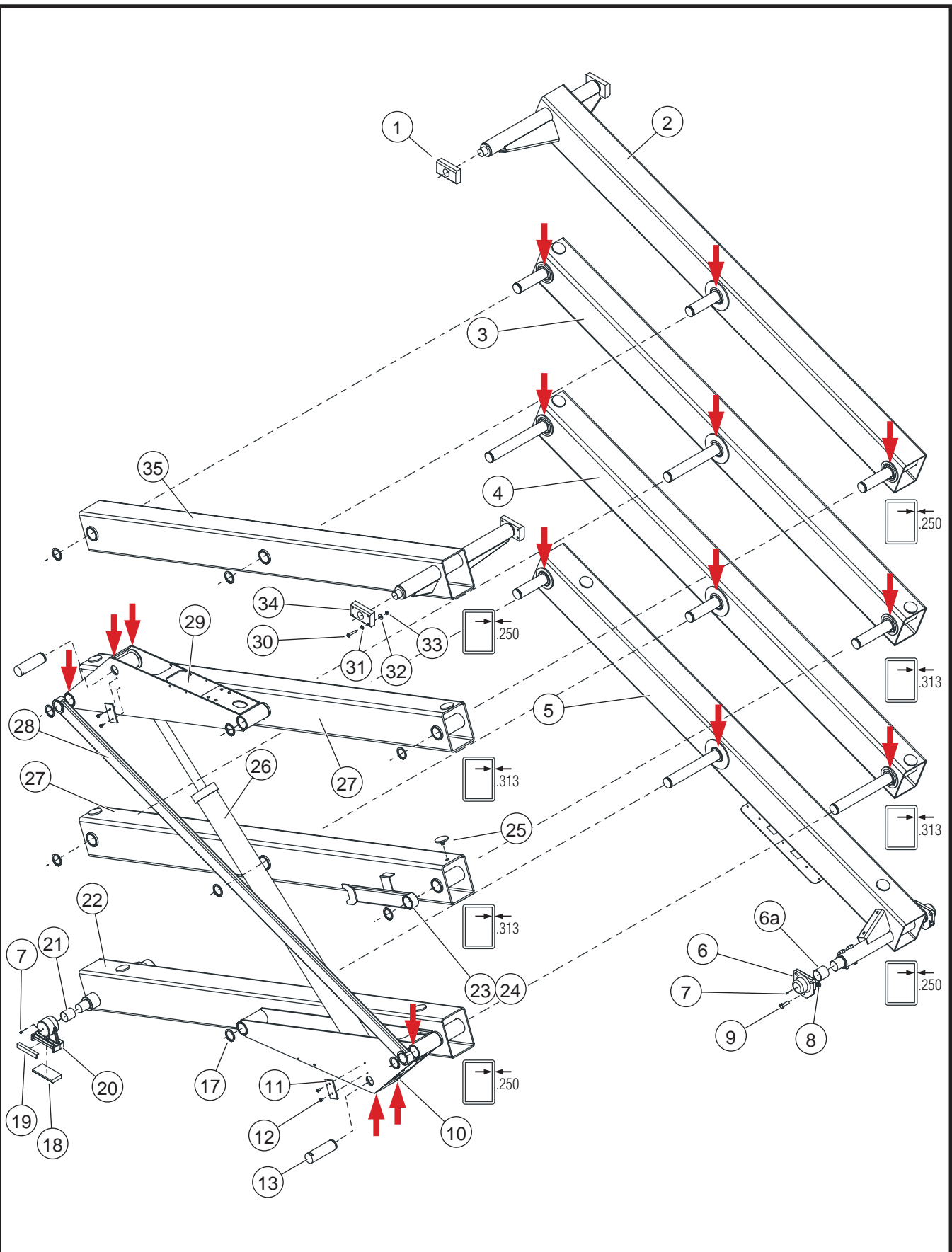

36 ↓ DENOTES LOCATION OF HDW13175, TOTAL QUANTITY OF 16

mecc
ILLUSTRATION No.
ART_2592 R1

Early Style

Scissor Assembly, 3072

Scissor Assembly, 3072RT: Up to Serial #11211099

ITEM	PART NO.	QTY	DESCRIPTION
1	14488	2	Block, Slide, Platform
2	40448	1	Beam, 6 × 8 × .250, Top Slide, W/pins
3	40084	1	Beam, 6 × 8 × .313 W/pins
4	40081	1	Beam, 6 × 8 × .313 W/pins
5	40444	1	Beam, 6 × 8 × .250, Bottom Fixed, W/pins
6	40459	2	Lower Pivot, Machined Casting
6a	6669	2	Bearing, 2" × 2"
7	5432	4	Grease Fitting
8	HDW8457	6	Locknut, ½" - 13, GR B
9	HDW8284	6	Screw, ½" - 13, 2" LG, GR 8
10	HDW8899	2	Ring, Retaining (Not Shown)
11	14538	2	Bracket, Cylinder Retaining
12	HDW6455	4	Screw, ¼" - 20, ½" LG
13	14537	2	Pin, Cylinder Mount
14	-	-	-
15	-	-	-
16	-	-	-
17	6701	10	Ring, Retaining, 2"
18	9587	2	Wear Pad, Slide Block, Bottom
19	90235	2	Wear Pad, Angle, Slide Block Top
20	40306	2	Slide Pvt, Lwr Cast, Machined
	8785	.67 FT	Tape, Double Coated
21	7160	2	Bearing, 1 ¾" × 2"
22	40446	1	Beam, 6 × 8 × .250, Bottom Slide, W/bearings
23	14990	1	Maintenance Lock Weldment
24	8675	1	Bearing, 2 ¼" × 2" × 1 ½" LG (not shown)
25	25429	12	Spacer Block - Beams
26	91020	1	Lift Cylinder
27	40083	2	Beam, 6 × 6 × .313
	6669	4	Bearing, 2" × 2" (Not Shown)
28	14806	1	Support Beam Weldment
29	16283	2	Cylinder Mount
30	HDW8303	8	Screw, 5/16" - 18, 2" LG
31	HDW5217	8	Washer, Flat, .343 ID × .688 OD × .063 THK
32	HDW8294	8	Washer, Flat, .328 ID × 1.000 OD × .100 THK
33	HDW8304	8	Nut, 5/6" - 18
34	14487	2	Block, Slide, Platform
35	40447	1	Beam, 6 × 8 × .250, Top Fixed, W/bearings
36	HDW13175	16	Washer, 2.062 ID × 2.620 OD × .030 THK (not shown)

• as req: as required

• INCL: Included with assembly

• NS: Not a Stock item

• REF: Reference only



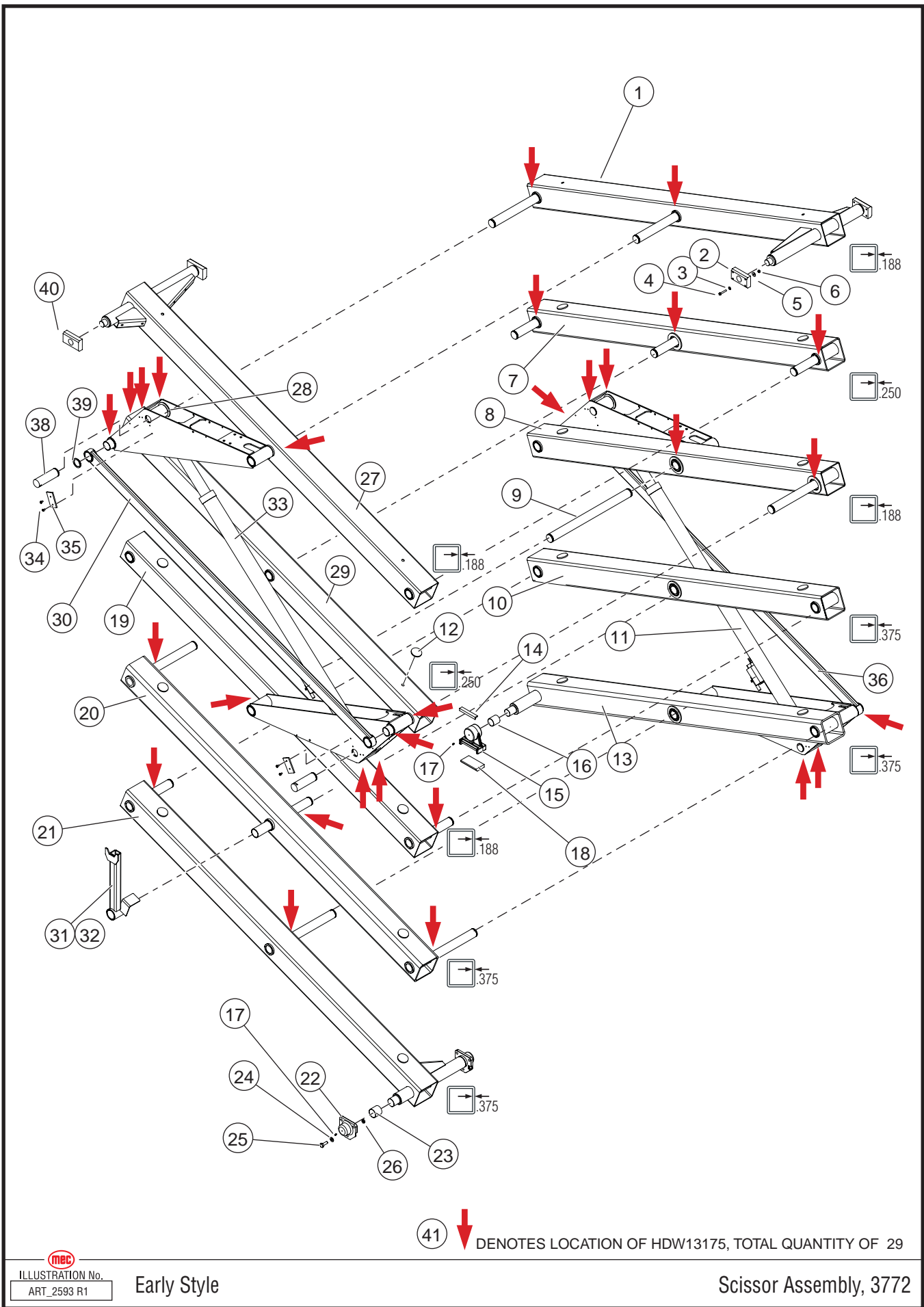



 ILLUSTRATION No.
 ART_2593 R1

Early Style

Scissor Assembly, 3772

Scissor Assembly, 3772RT: Up to Serial #11211099

ITEM	PART NO.	QTY	DESCRIPTION
1	16290	1	Beam 6 x6 x.188
2	14487	2	Block, Slide, Platform
3	HDW5217	8	Washer, Flat, .343 ID x .688 OD x .063THK
4	HDW8303	8	Screw, 5/16" - 18, 2.00" LG
5	HDW8294	8	Washer, Flat, .328 ID x 1.000 OD x .100 THK
6	HDW8304	8	Nut, 5/16 - 18
7	40124	1	Beam 6 x 6 x .250
8	16289	1	Beam 6 x6 x.188
9	30407	1	Pin 2.00 DIA x 25.90" LG
10	16292	1	Beam 6 x 6 x.375 W/Bearings
11	91314	1	Lift Cylinder, Lower
12	25429	16	Spacer Block - Beams
13	16285	1	Beam 6 x 6 x.375, Bottom Fitted
14	90235	2	Wear Pad, Anle, Slide Block, Top
15	40306	2	Slide Pivot Lower Cast Machined
16	7160	2	Bearing, 1 3/4" x 2" - 28DU32
17	5432	4	Grease Fitting
18	9587	2	Wear pad, Slide block, Bottom
19	16286	1	Beam 6 x6 x.188
	6669	2	Bearing, 2.0 x 2.0 - 32DU32
20	40106	1	Beam 6 x6 x.375
	6669	2	Bearing, 2.0 x 2.0 - 32DU32
21	16284	1	Beam 6 x6 x.375
	6669	2	Bearing, 2.0 x 2.0 - 32DU32
22	40459	2	Casting, Machined, Lower Pivot
23	6669	2	Bearing, 2.0 x 2.0 - 32DU32
24	HDW6491	6	Washer, Flat, .562 ID x 1.375 OD x .109 THK
25	HDW8284	6	Bolt, 1/2" - 13, 2.00" LG GR8
26	HDW8457	6	Locknut, 1/2" - 13, GR8
27	16287	1	Beam 6 x 6 x.188 W/Pins
28	HDW8899	4	Ring, Retaining (not shown)
29	16288	1	Beam 6 x 6 x.250 w/Bearings
30	16282	1	Support Beam W/Bearings
31	30518	1	Maintenance Lock Weldment
32	8675	1	Bearing, 2 1/4" x 2" x 1 1/2" LG (not shown)
33	91315	1	Lift Cylinder, Upper
34	HDW6455	8	Screw, 1/4" - 20, 1/2" LG
35	14538	4	Bracket, Cylinder Retaining
36	14806	1	Support Beam Weldment
37	16283	4	Mount cylinder w/Cap
38	14537	4	Pin, Cylinder Mount, 1.998 x 6.408
39	6701	15	Ring, Retaining, 2" Shaft
40	14488	2	Block, Slide Platform
41	HDW13175	29	Washer, 2.062 ID x 2.620 OD x .030 THK (not shown)

• as req: as required

• INCL: Included with assembly

• NS: Not a Stock item

• REF: Reference only



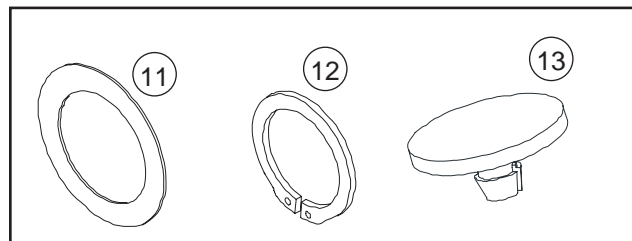
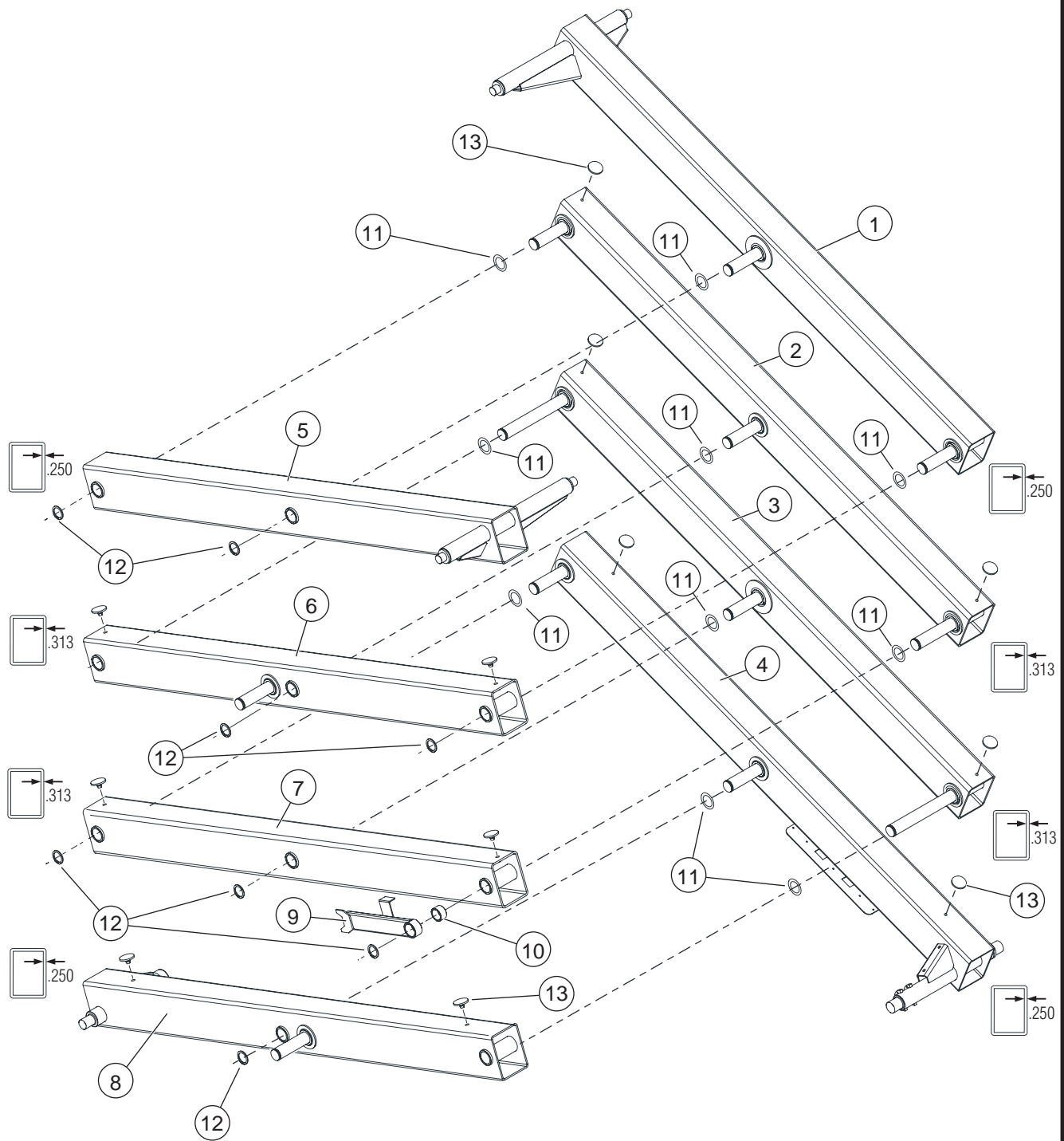



 ILLUSTRATION No.
 ART_2594

3072RT - 3072ES: Sheet 1 of 2

Scissor Assembly, Beams Install

Scissor Assembly, 3072RT: Serial #11211100 - UP

ITEM	PART NO.	QTY	DESCRIPTION
1	40448	1	Beam, 6x8x.250 TS w/pins
2	17070	1	Beam, 6x8x.313 w/pins
3	40081	1	Beam, 6x8x.313 w/pins
4	17071	1	Beam, 6x8x.250 BF w/pins
5	40447	1	Beam, 6x8x.250 TF w/Bearings
6	17067	1	Beam, 6x6x.312 bored
7	40083	1	Beam, 6x6x.312 bored
8	17065	1	Beam, 6x8x.250 BS w/Bearings
9	14990	1	Maintenance Lock Weldment
10	8675	1	Bearing, 2 1/4" x 2" x 1 1/2" LG
11	13175	16	Washer, Nylon 2.062 ID x 2.620 OD x .030 THK
12	6701	12	Ring, Retaining, 2"
13	25429	12	Spacer Block - Beams

... continued

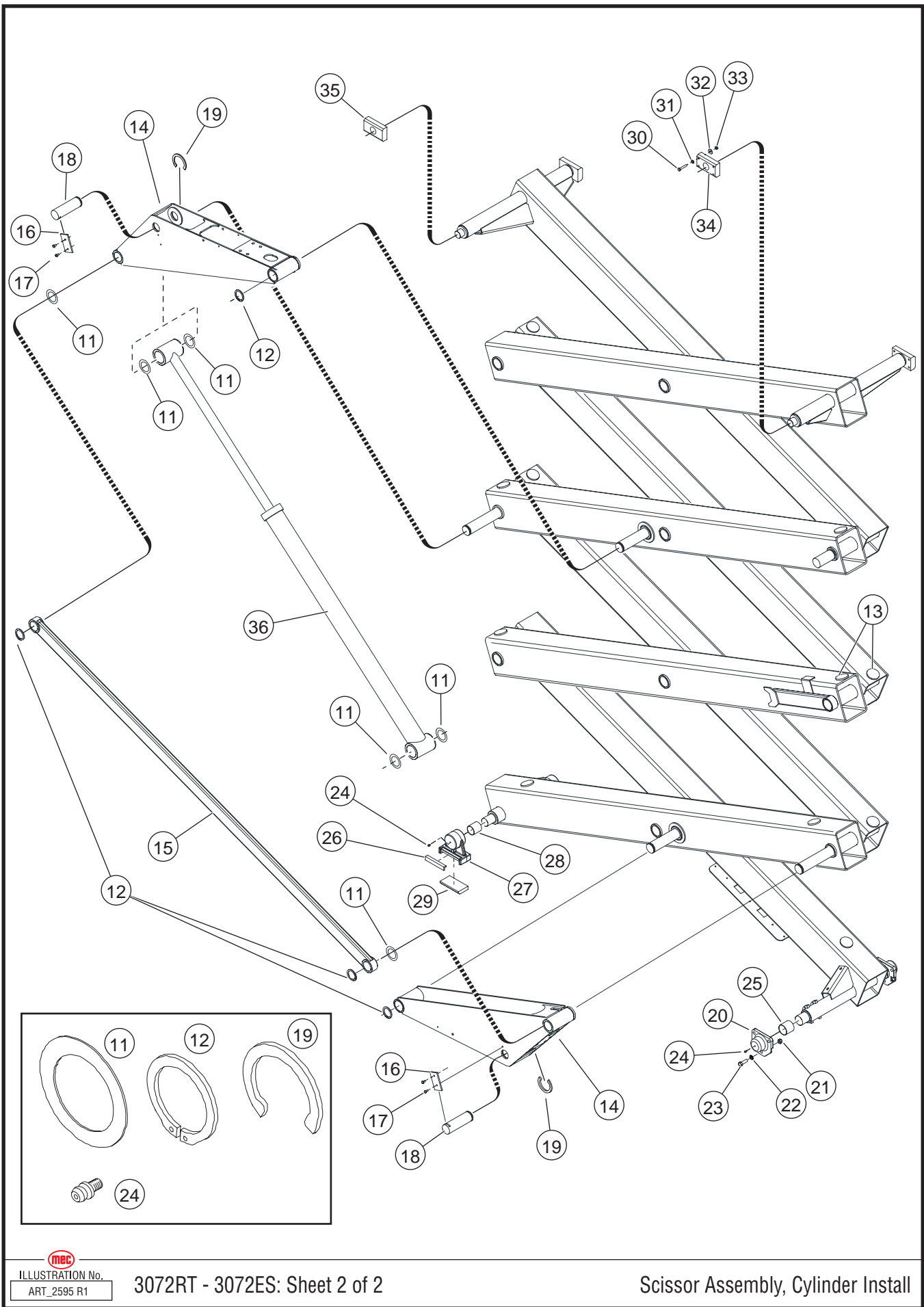



 ILLUSTRATION No.

 ART_2595 R1

3072RT - 3072ES: Sheet 2 of 2

Scissor Assembly, Cylinder Install

Scissor Assembly, 3072RT: Serial #11211100 - UP (continued)

ITEM	PART NO.	QTY	DESCRIPTION
11	13175	16	Washer, Nylon 2.062 ID x 2.620 OD x .030 THK
12	6701	12	Ring, Retaining, 2"
13	25429	12	Spacer Block - Beams
14	17012	2	CYLINDER MOUNT
15	14806	1	SUPPORT BEAM WELDMENT
16	14538	2	BRACKET, CYLINDER RETAINING
17	HDW6455	4	SCREW, ¼" - 20, ½" LG
18	14537	2	PIN, CYLINDER MOUNT
19	HDW8899	2	Retaining Clip
20	40459	2	LOWER PIVOT, MACHINED CASTING
21	HDW8457	6	LOCKNUT, ½" - 13, GR B
22	HDW6491	6	Washer, Flat, .562 ID x 1.375 OD x .109 THK
23	HDW8284	6	SCREW, ½" - 13, 2" LG, GR 8
24	5432	4	GREASE FITTING
25	6669	2	BEARING, 2" x 2"
26	90235	2	WEAR PAD, ANGLE, SLIDE BLOCK TOP
27	40306	2	SLIDE PVT, LWR CAST, MACHINED
	8785	.67 FT	TAPE, DOUBLE COATED
28	7160	2	BEARING, 1 ¾" x 2"
29	9587	2	WEAR PAD, SLIDE BLOCK, BOTTOM
30	HDW8303	8	SCREW, 5/16" - 18, 2" LG
31	HDW5217	8	WASHER, FLAT, .343 ID x .688 OD x .063 THK
32	HDW8294	8	WASHER, FLAT, .328 ID x 1.000 OD x .100 THK
33	HDW8304	8	NUT, 5/6" - 18
34	14487	2	BLOCK, SLIDE, PLATFORM
35	14488	2	BLOCK, SLIDE, PLATFORM
36	91020	1	Lift Cylinder

• as req: as required

• INCL: Included with assembly

• NS: Not a Stock item

• REF: Reference only



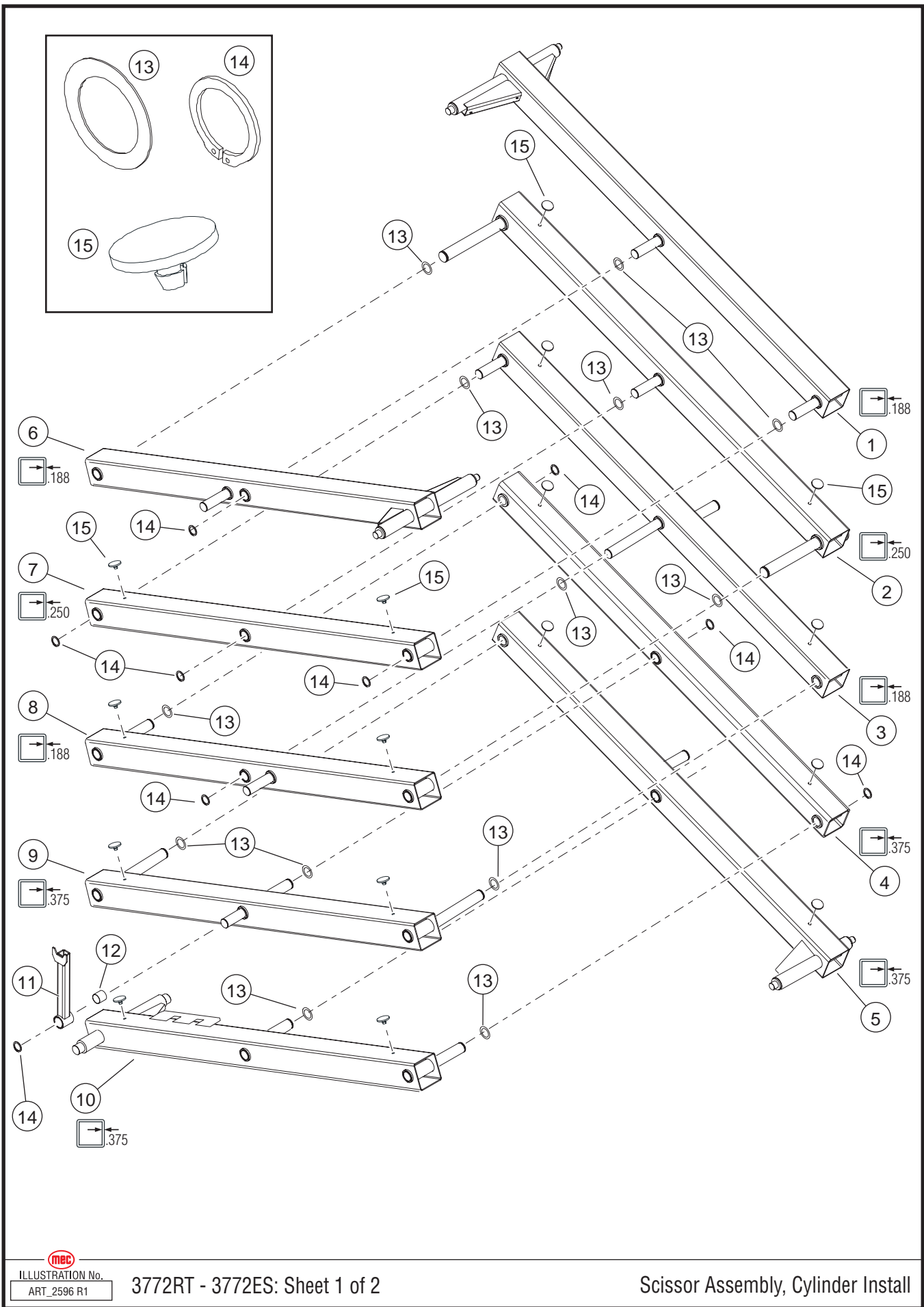



 ILLUSTRATION No.
 ART_2596 R1

3772RT - 3772ES: Sheet 1 of 2

Scissor Assembly, Cylinder Install

Scissor Assembly, 3772RT: Serial #11211100 - UP

ITEM	PART NO.	QTY	DESCRIPTION
1	17019	1	Beam Weldment, 6x6x.188
2	17017	1	Beam Weldment, 6x6x.250
3	17015	1	Beam Weldment, 6x6x.188
4	16292	1	Beam Weldment, 6x6x.375
5	17011	1	Beam Weldment, 6x6x.375
6	17018	1	Beam Weldment, 6x6x.188
7	16288	1	Beam Weldment, 6x6x.250
8	17014	1	Beam Weldment, 6x6x.188
9	40106	1	Beam Weldment, 6x6x.375
10	17009	1	Beam Weldment, 6x6x.375
11	30518	1	Maintenance Lock Weldment
12	8675	1	Bearing, 2 1/4" x 2" x 1 1/2" LG
13	HDW13175	21	Washer, 2.062 ID x 2.620 OD x .030 THK
14	6701	17	Ring, Retaining, 2" Shaft
15	25429	16	Spacer Block - Beams

... continued

• as req: as required

• INCL: Included with assembly

• NS: Not a Stock item

• REF: Reference only



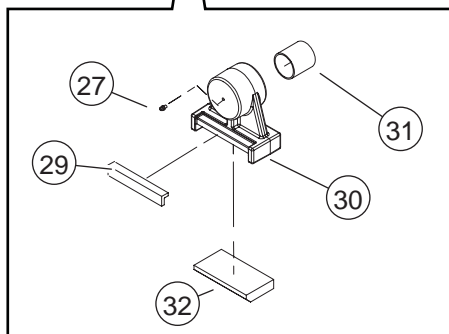
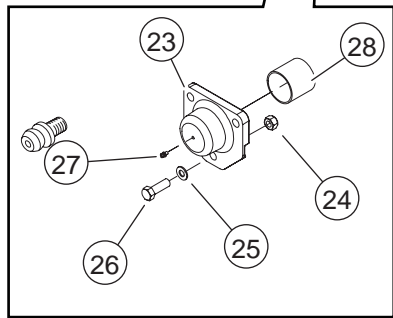
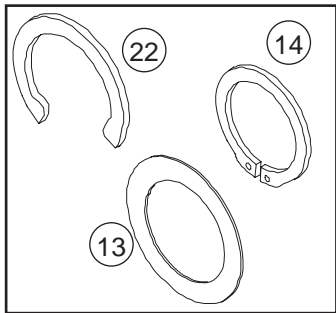
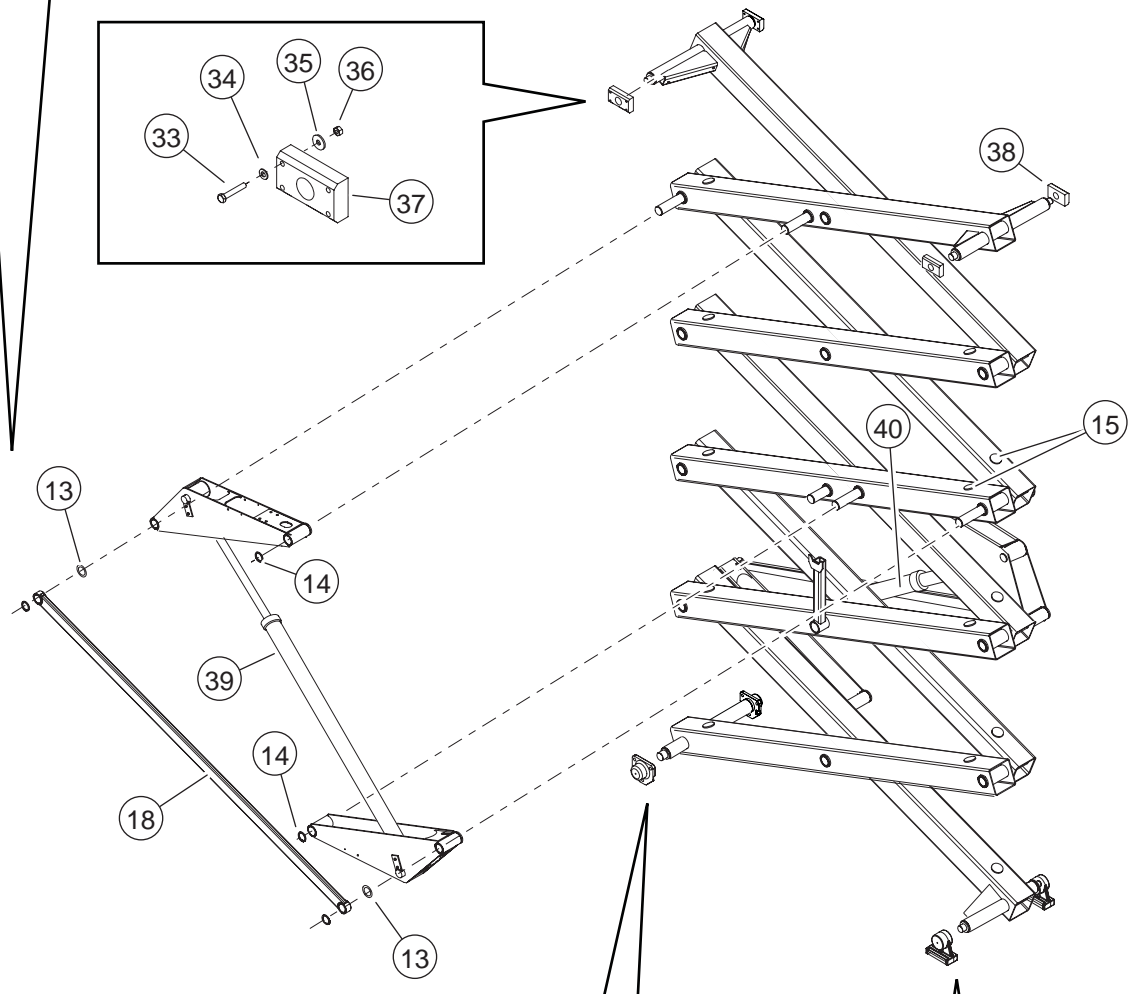
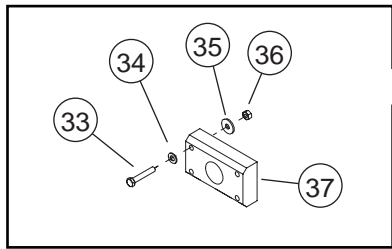
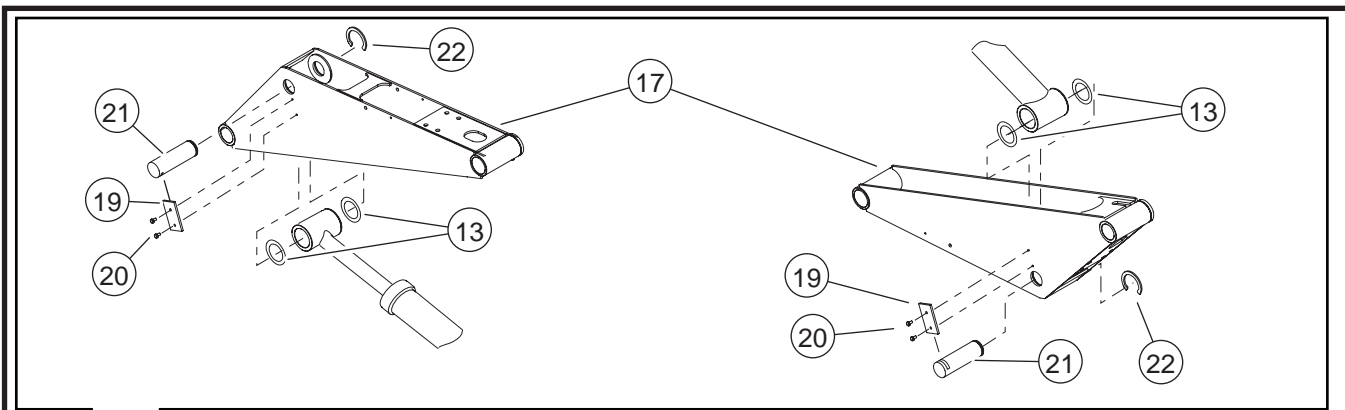

mecc
ILLUSTRATION No.
ART_2597 R1

3772RT - 3772ES: Sheet 2 of 2

Scissor Assembly, Cylinder Install

Scissor Assembly, 3772RT: Serial #11211100 - UP (continued)

ITEM	PART NO.	QTY	DESCRIPTION
13	HDW13175	21	Washer, 2.062 ID x 2.620 OD x .030 THK
14	6701	17	Ring, Retaining, 2" Shaft
15	25429	16	Spacer Block - Beams
16	-	-	-
17	17012	4	CYLINDER MOUNT
18	16282	2	SUPPORT BEAM WELDMENT w/Bearings
19	14538	4	BRACKET, CYLINDER RETAINING
20	HDW6455	8	SCREW, 1/4" - 20, 1/2" LG
21	14537	4	PIN, CYLINDER MOUNT
22	HDW8899	4	Retaining Clip
23	40459	2	LOWER PIVOT, MACHINED CASTING
24	HDW8457	6	LOCKNUT, 1/2" - 13, GR B
25	HDW6491	6	Washer, Flat, .562 ID x 1.375 OD x .109 THK
26	HDW8284	6	SCREW, 1/2" - 13, 2" LG, GR 8
27	5432	4	GREASE FITTING
28	6669	2	BEARING, 2" x 2"
29	90235	2	WEAR PAD, ANGLE, SLIDE BLOCK TOP
30	40306	2	SLIDE PVT, LWR CAST, MACHINED
	8785	.67 FT	TAPE, DOUBLE COATED
31	7160	2	BEARING, 1 3/4" x 2"
32	9587	2	WEAR PAD, SLIDE BLOCK, BOTTOM
33	HDW8303	8	SCREW, 5/16" - 18, 2" LG
34	HDW5217	8	WASHER, FLAT, .343 ID x .688 OD x .063 THK
35	HDW8294	8	WASHER, FLAT, .328 ID x 1.000 OD x .100 THK
36	HDW8304	8	NUT, 5/6" - 18
37	14487	2	BLOCK, SLIDE, PLATFORM
38	14488	2	BLOCK, SLIDE, PLATFORM
39	91315	1	Lift Cylinder, Upper
40	91314	1	Lift Cylinder, Lower

• as req: as required

• INCL: Included with assembly

• NS: Not a Stock item

• REF: Reference only



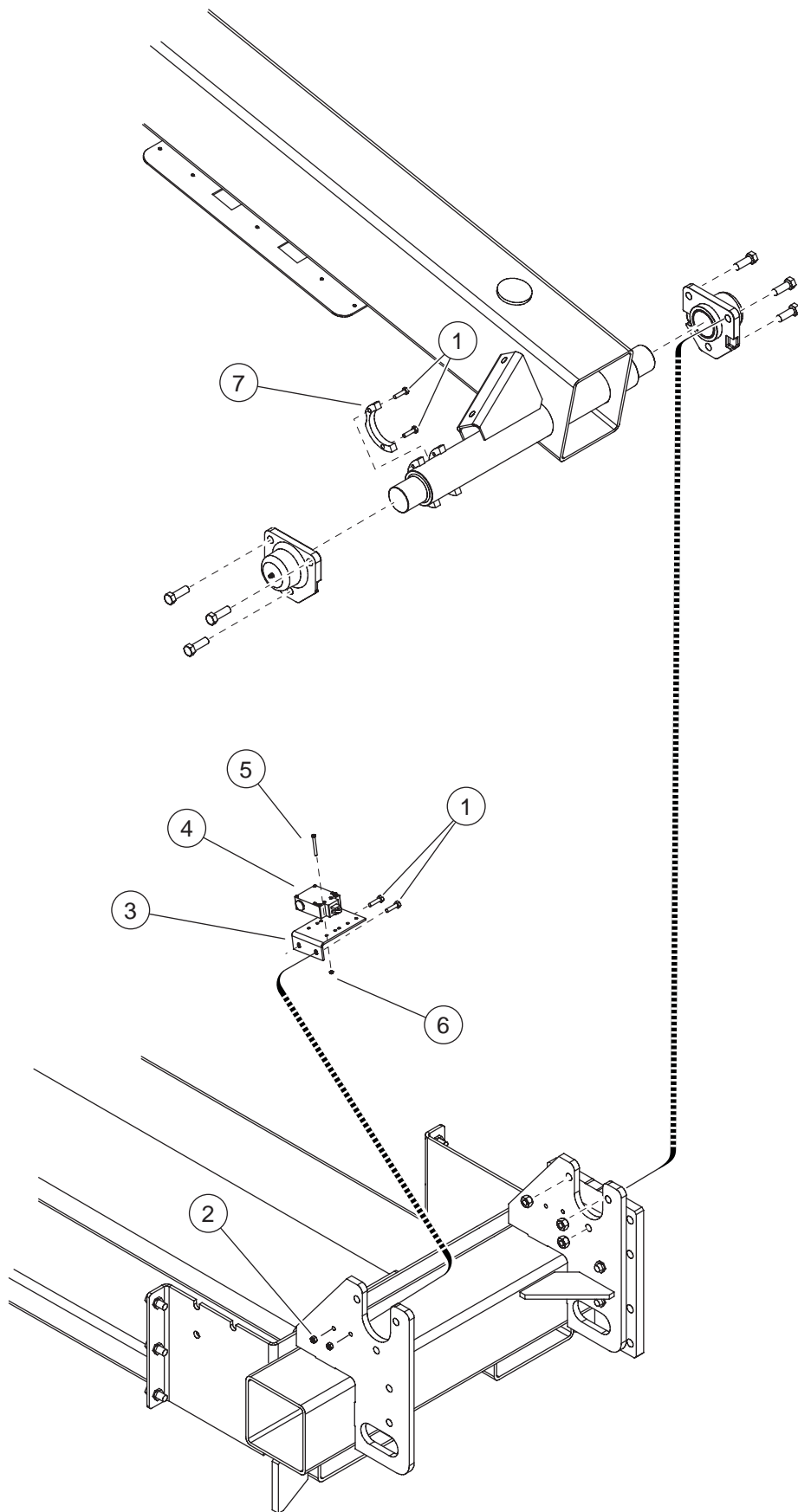

ILLUSTRATION No.
ART_2598 R1

Limit Switch Installation

Limit Switch Installation

ITEM	PART NO.	QTY	DESCRIPTION
1	HDW8273	4	Screw, ¼"-20, 1" LG, GR 8
2	HDW8267	2	NUT, ¼"-20
3	13838	1	BRKT, LIMIT SWITCH
4	90996	1	LIMIT SWITCH, SLOW SPEED
5	HDW8482	2	Screw, #8-32, 1 ½" LG, GR 2
6	HDW5251	2	NUT, #8-32
7	40524	1	CAM, Slow Speed, 2.75 DIA.

• as req: as required

• INCL: Included with assembly

• NS: Not a Stock item

• REF: Reference only



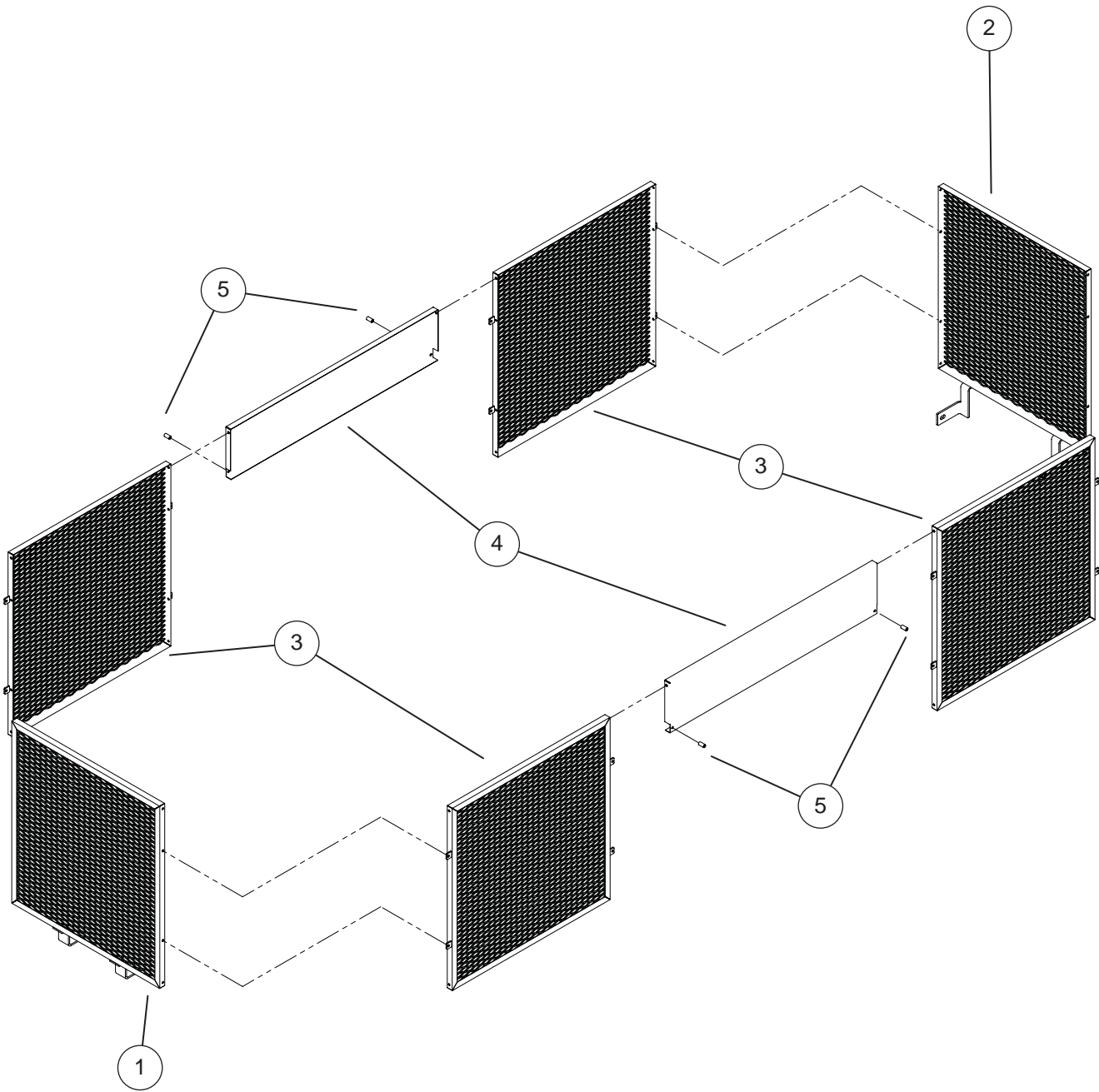

Scissor Guards - 3072ES, CE Models

ITEM	PART NO.	QTY	DESCRIPTION
1	16323	1	Front Panel, Scissor Guard
2	16324	1	Rear Panel, Scissor Guard
3	16325	4	Side Panel, Scissor Guard
4	16320	2	Mid Panel, Scissor Guard
5	16332	4	Spacer

• as req: as required

• INCL: Included with assembly

• NS: Not a Stock item

• REF: Reference only



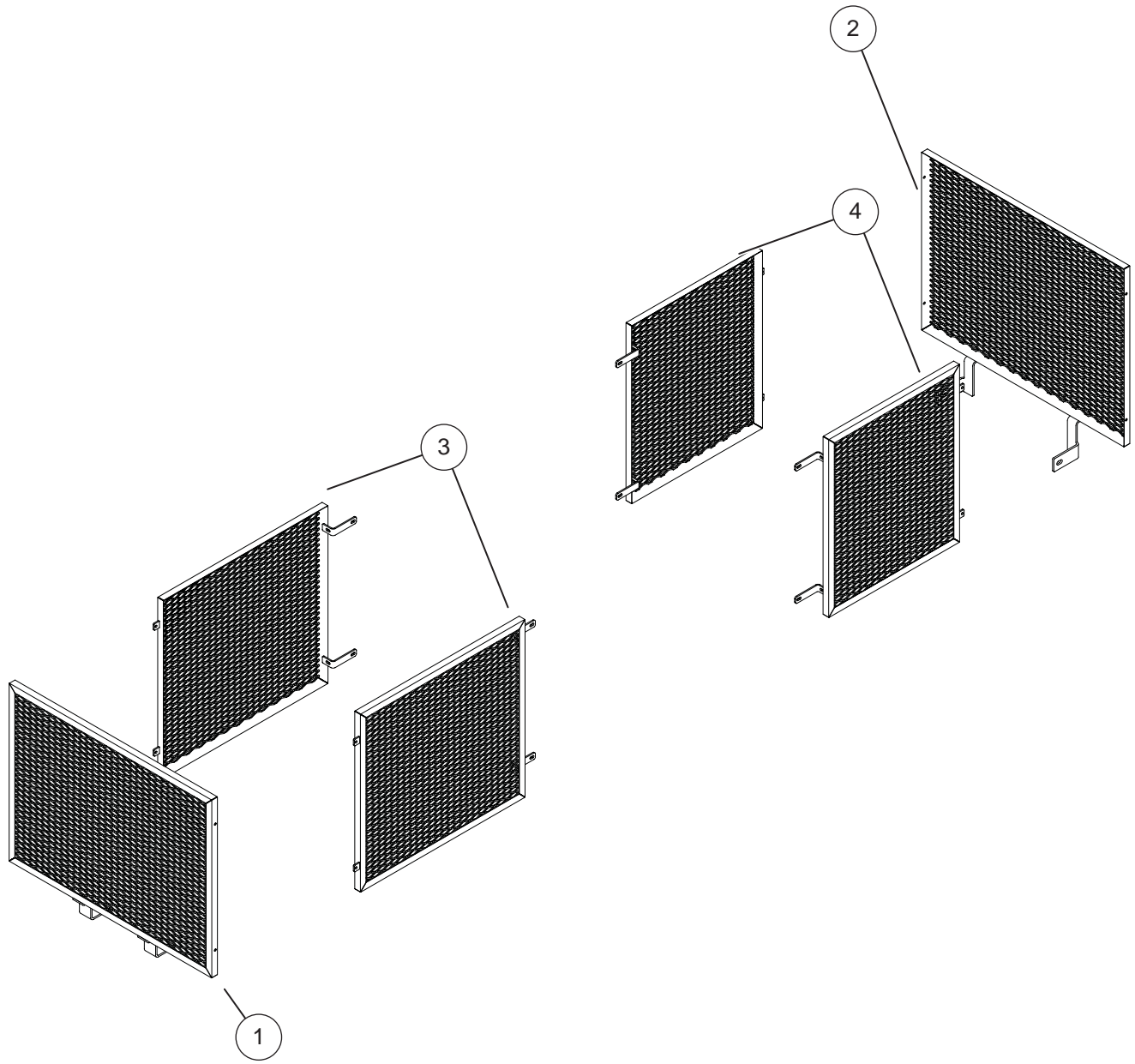



ILLUSTRATION No.
ART_2744

3772RT - 3772ES CE MODELS

Scissor Guards

Scissor Guards - 3772ES, CE Models

ITEM	PART NO.	QTY	DESCRIPTION
1	16350	1	Front Panel, Scissor Guard
2	16353	2	Rear Panel, Scissor Guard
3	16355	2	Side Panel, Scissor Guard
4	16359	2	Side Panel, Scissor Guard

• as req: as required

• INCL: Included with assembly

• NS: Not a Stock item

• REF: Reference only



NOTES:



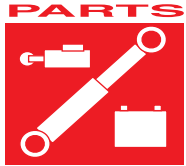

SECTION D

AXLES

CONTENTS	PAGE
Rear Axle Assembly	D-3
Front Axle Assembly	D-5
Wheel Motor, Rear	D-7
Wheel Motor, Front	D-9



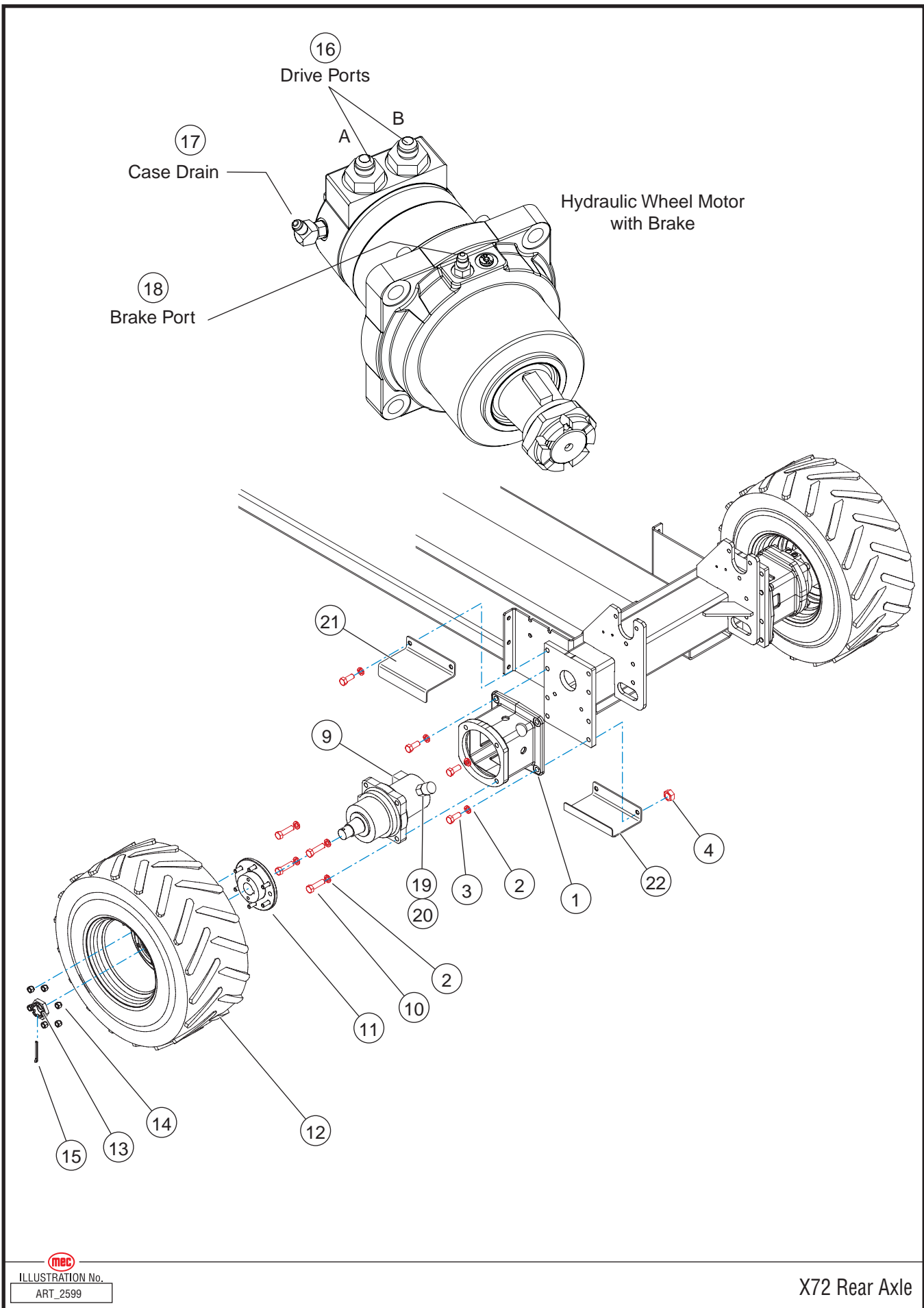

MEC
 ILLUSTRATION No.
 ART_2599

X72 Rear Axle

Rear Axle Assembly

ITEM	PART NO.	QTY	DESCRIPTION
1	40258	2	Mount, Motor, Rear Axle, Machined
2	HDW5994	20	Washer, Lock, .640 ID X 1.050 OD X .165 THK
3	HDW90409	12	Bolt, 5/8" - 11, 1 1/2" LG
4	6633	4	Nut, 5/8" - 11
5	-	-	-
6	-	-	-
7	-	-	-
8	90765	4	Hose Protection (not shown)
9	91319	2	Wheel Motor, Hyd W/brake
10	HDW5989	8	Screw, 5/8"-11, 2.25" LG, GR 5
11	14773	2	Hub
12	91165	1	Wheel/tire Assy, RH - 10 PLY - PNEUMATIC (ANSI standard)
	91167	1	Wheel/tire Assy, RH - 10 PLY - FOAM (ANSI option) (CE standard)
	91166	1	Wheel/tire Assy, LH - 10 PLY - PNEUMATIC (ANSI standard)
	91168	1	Wheel/tire Assy, LH - 10 PLY - FOAM (ANSI option) (CE standard)
	91180	-	Wheel (service)
	91181	-	Tire 26x12.00-380 (service)
13	HDW9037	-	Nut, Castle, M42 X 3 (service)
14	HDW6677	12	Nut, Lug, 1/2" - 20, GR 5
15	8925	2	Pin, Cotter, .250 DIA. X 3" LG
16	HDW8984	4	Fitting, MB-MJ-12-8
17	HDW91235	2	Fitting, MB-MJ45-4-5
18	HDW8881	2	Fitting, MB-MJ-4-4
19	91585	2	Valve, Solenoid Assembly
20	91464	2	Valve, nc poppet
	91141	2	Coil, 12V Deutsch
21	16348	2	Cover, Upper Control Valve Shield
22	16349	2	Cover, Lower Control Valve Shield

• as req: as required

• INCL: Included with assembly

• NS: Not a Stock item

• REF: Reference only



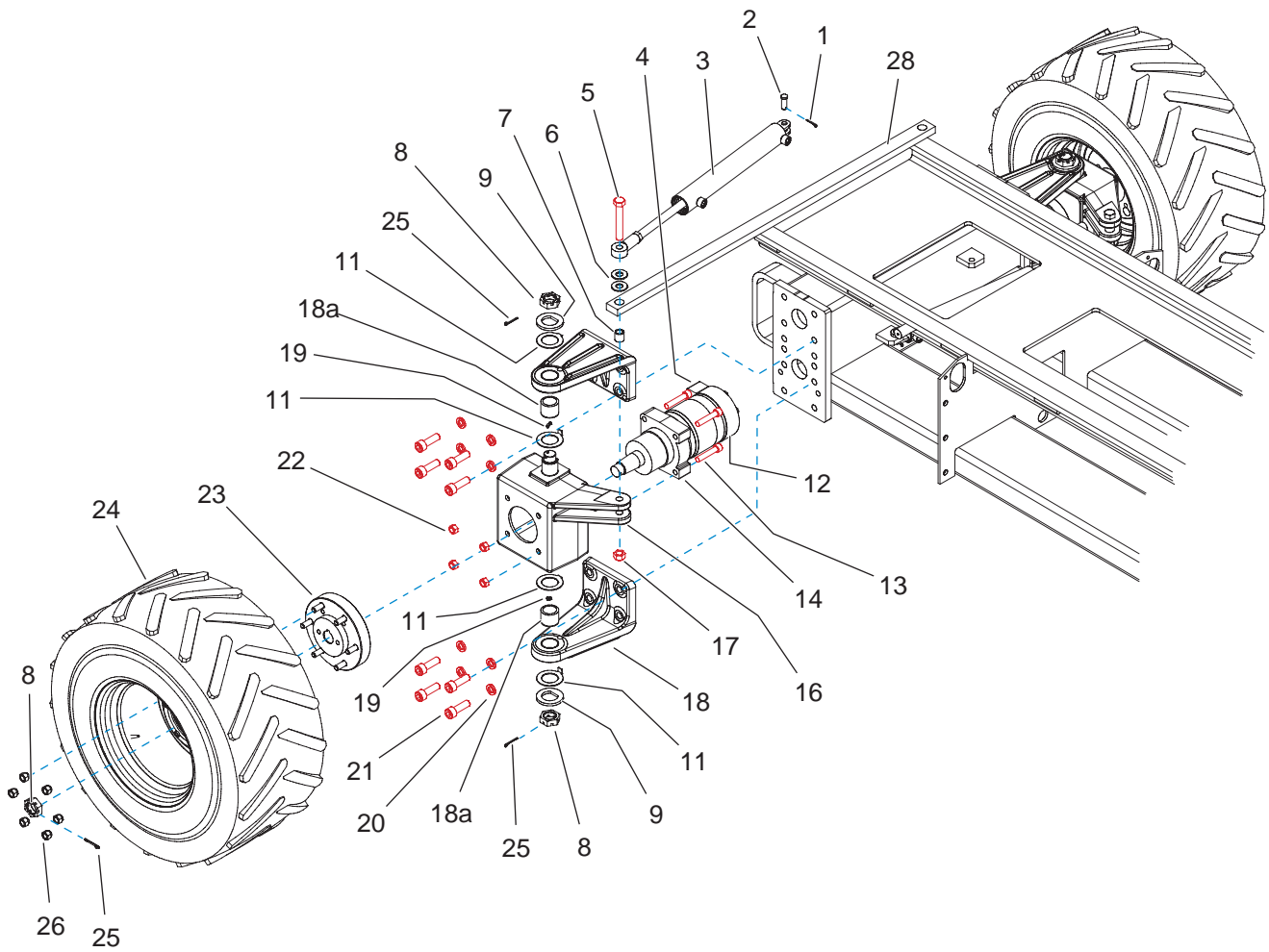
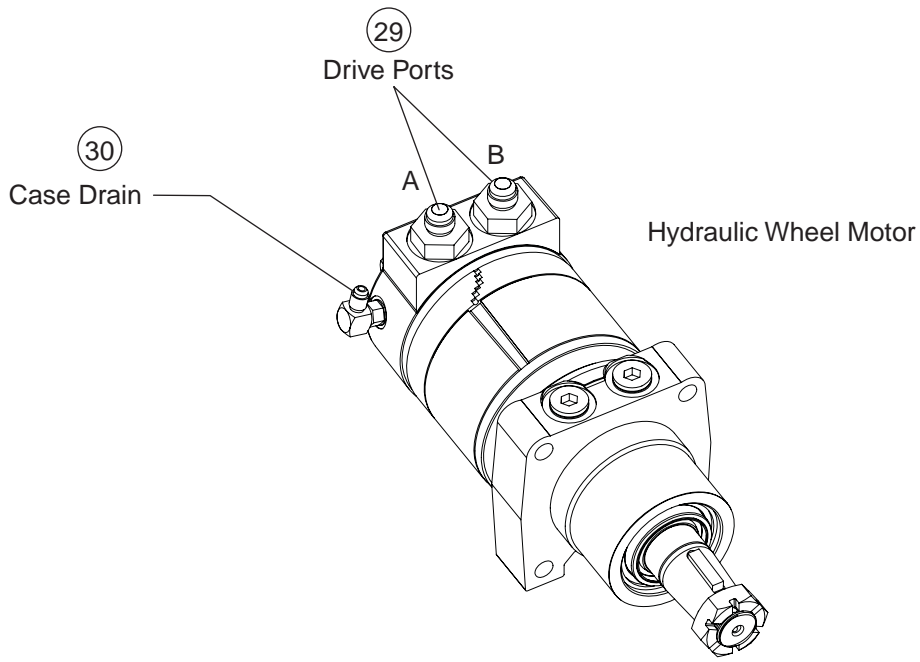

Front Axle Assembly

ITEM	PART NO.	QTY	DESCRIPTION
1	HDW5920	2	Pin, Cotter, .12 DIA. X 1" LG
2	HDW90770	2	Pin, Clevis, ½ DIA. X 1 3/8" LG
3	91019	2	Cylinder, Steering
	90990	–	Seal Kit, Steer Cylinder (not shown)
4	91263	4	Hose Assembly ½" (8M3K-8FJX-8FJX90S-37")
5	HDW7326	2	Screw, 5/8" - 11. 4" LG, GR 5
6	HDW9219	4	Washer, .656 ID X 1.312 OD X .093 THK
7	7292	2	Bearing, Sleeve, Bronze
8	HDW8568	6	Nut, 1 1/8" - 18
9	20311	4	Washer, 1.375 ID X 2.75 OD X .250 THK
10	–	–	–
11	20312	8	Washer, Thrust
12	90282	1	Hose Assembly 5/16" (Not Shown)
13	HDW7043	8	Screw, ½"-13, 2.50" LG, GR 8, Socket Head
14	7300P	2	Motor, Wheel, Hyd.
15	90765	8	Hose Protection (Not Shown)
16	40464	1	Mount, Wheel Motor, LH, FRONT (cast 40463)
	40308	1	Mount, Wheel Motor, RH, FRONT (cast 40367)
17	HDW6633	2	Nut, Lock, 5/8" - 11, GR 5
18	40334	4	Mount, Motor W/Bearings
18a	9307	4	Bearing, 1.50 x 1.0 DIA
19	9607	2	Fitting, Grease, 90°
20	HDW5994	16	washer, lock, .640 ID X 1.050 OD X .165 THK
21	HDW90410	16	Screw, 5/8" - 11, 2" LG, GR 8, Socket Head
22	HDW8457	8	Nut, ½"-13, GR8
23	10709	2	Hub
24	91165	1	Wheel/tire Assy, RH - 10 PLY - PNEUMATIC (ANSI standard)
	91167	1	Wheel/tire Assy, RH - 10 PLY - FOAM (ANSI option) (CE standard)
	91166	1	Wheel/tire Assy, LH - 10 PLY - PNEUMATIC (ANSI standard)
	91168	1	Wheel/tire Assy, LH - 10 PLY - FOAM (ANSI option) (CE standard)
25	HDW5290	6	Pin, Cotter, .156 DIA. X 1.75" LG
26	HDW6677	12	Nut, Lug, ½" - 20, GR 5
27	–	–	–
28	14331	1	Rod, Tie Steering
29	HDW8984	4	Fitting, MB-MJ-12-8
30	HDW91236	2	Fitting, MB-MJ90-4-5

• as req: as required

• INCL: Included with assembly

• NS: Not a Stock item

• REF: Reference only



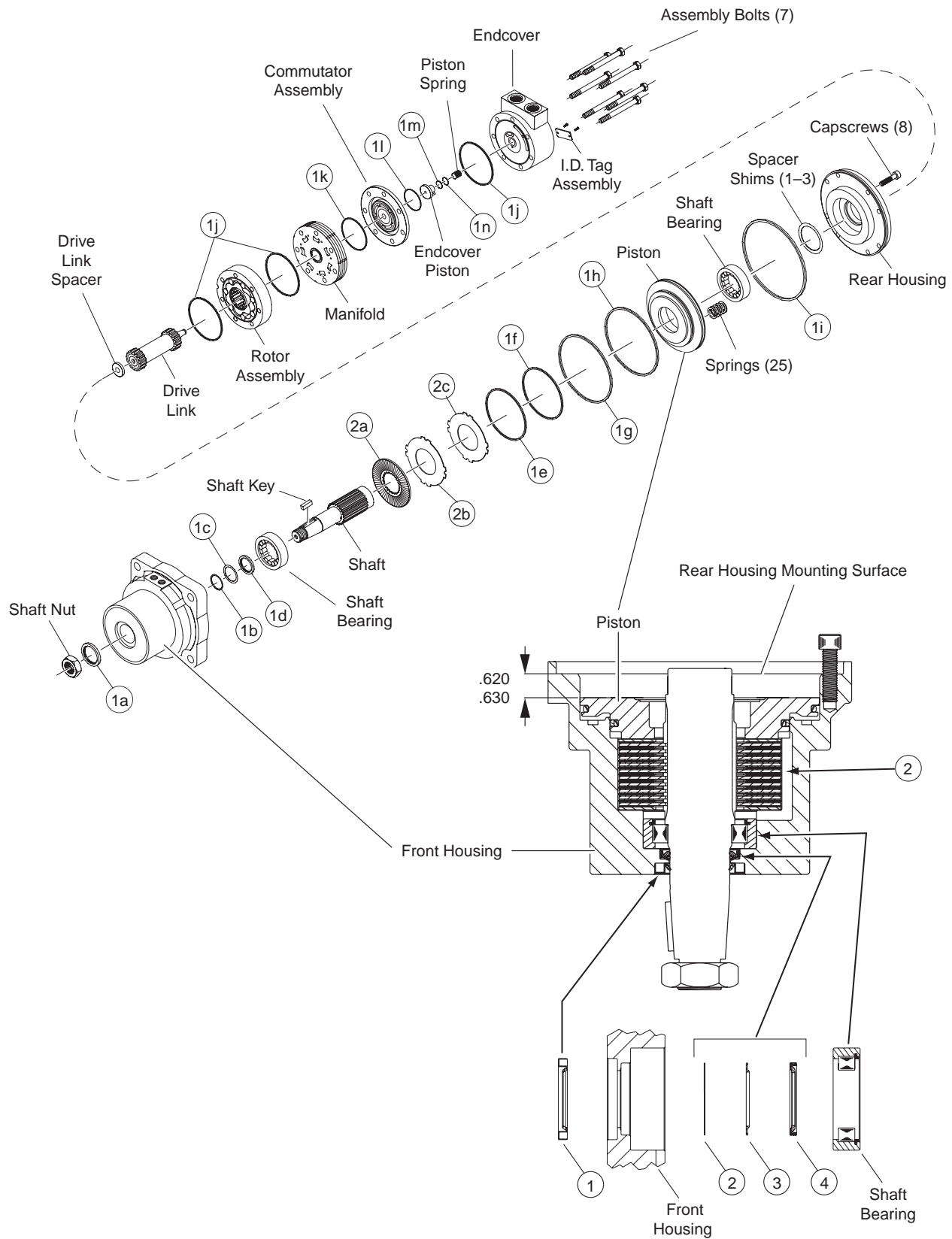



 ILLUSTRATION No.
 ART_2397 R1

DT710 BRAKE MOTOR COMPONENTS

X72 Wheel Motor, Rear

Wheel Motor, Rear

ITEM	PART NO.	QTY	DESCRIPTION
-	91319	-	Wheel Motor W/brake
1	9781	-	Seal Kit
1a	-	1	Dust Seal
1b	-	1	Metal Backup Shim
1c	-	1	Backup Seal
1d	-	1	Shaft Seal
1e	-	1	Small Piston O-ring Seal
1f	-	1	Small Piston Seal
1g	-	1	Large Piston O-ring Seal
1h	-	1	Large Piston Seal
1i	-	1	O-ring Seal
1j	-	3	Body Seal
1k	-	1	Manifold Seal
1l	-	1	Commutator Seal
1m	-	1	O-ring Seal
1n	-	1	Backup Seal
2	91138	-	Disk Kit
2a	-	10	Friction Disk
2b	-	9	Disk Stamping
2c	-	2	Thick Disk Stamping

• as req: as required

• INCL: Included with assembly

• NS: Not a Stock item

• REF: Reference only



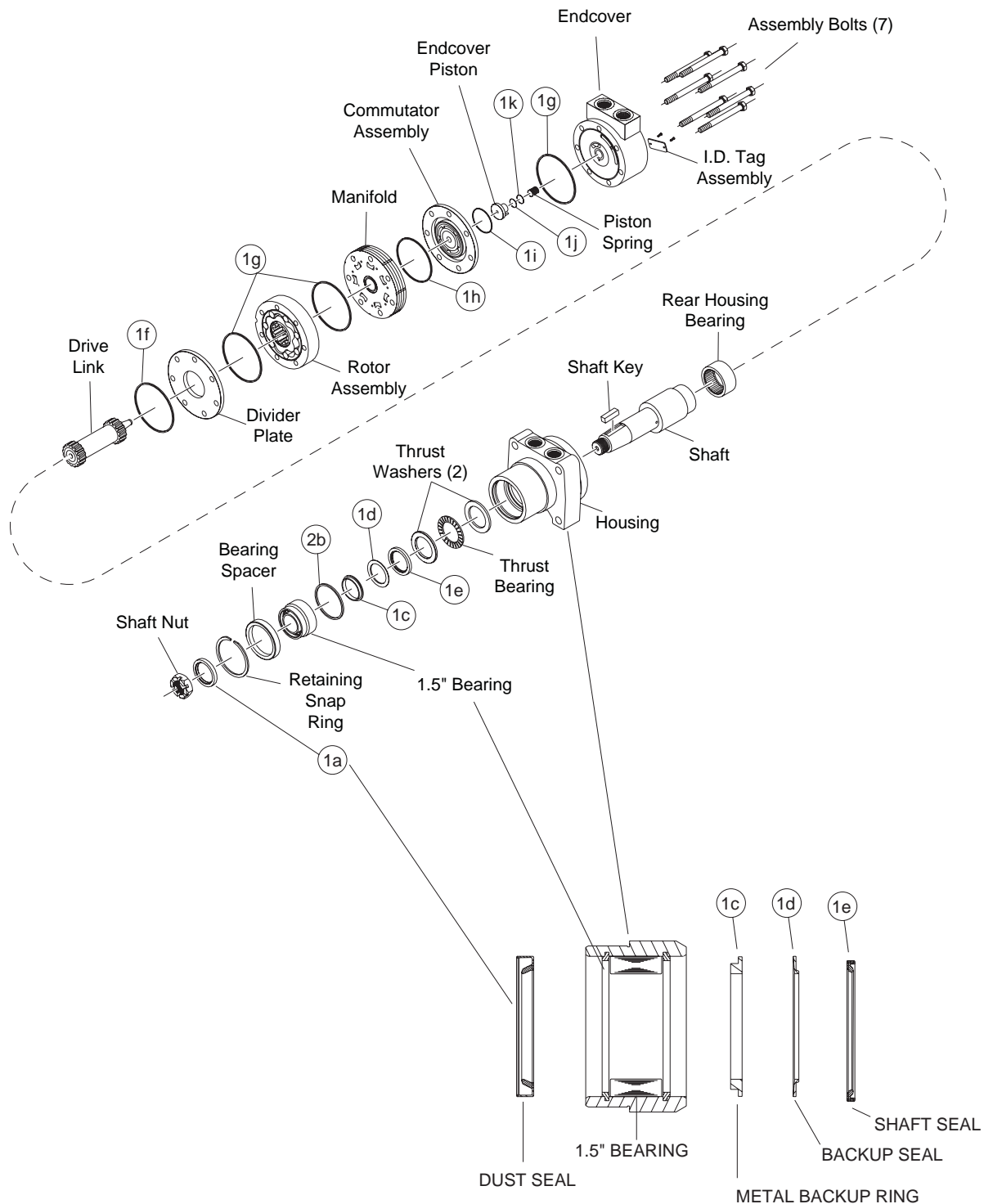

Wheel Motor, Front

ITEM	PART NO.	QTY	DESCRIPTION
–	7300P	–	MOTOR WHEEL HYD PAINTED
1	90592	–	SEAL KIT
1a	–	1	DUST SEAL
1b	–	1	HIGH PRESSURE SEAL
1c	–	1	METAL BACKUP SHIM
1d	–	1	TEFLON BACK UP SEAL
1e	–	1	SHAFT SEAL
1f	–	1	HOUSING SEAL
1g	–	3	BODY SEALS
1h	–	1	MANIFOLD SEAL
1i	–	1	COMMUTATOR SEAL
1j	–	1	O-RING SEAL
1k	–	1	TEFLON BACKUP SEAL

• as req: as required

• INCL: Included with assembly

• NS: Not a Stock item

• REF: Reference only



NOTES:



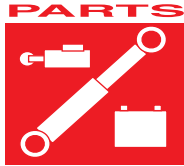

SECTION E

HYDRAULICS

CONTENTS	PAGE
Main Manifold Assembly	E-3
Main Manifold Assembly (continued)	E-5
Main Relief Manifold Assembly	E-7
Manifold - Outrigger (HD Models)	E-9
Hydraulic Hoses - Axles	E-11
Hydraulic Hoses - Steering, Brake Release and Axle Return	E-13
Hydraulic Hoses - Pump and Return	E-15
Hydraulic Hoses - Outrigger (HD Models)	E-17
Lift Cylinder, 3072	E-19
Lift Cylinder, Lower, 3772	E-21
Lift Cylinder, Upper, 3772	E-23
Steering Cylinder	E-25
Outrigger Cylinder	E-27



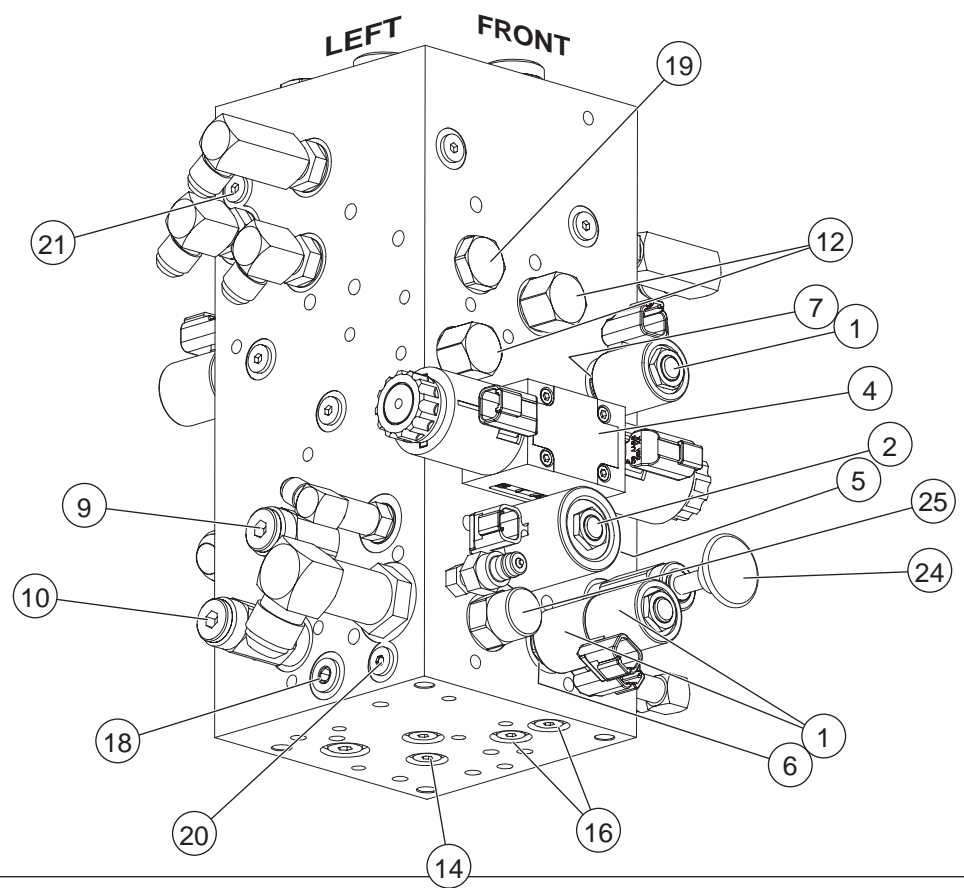
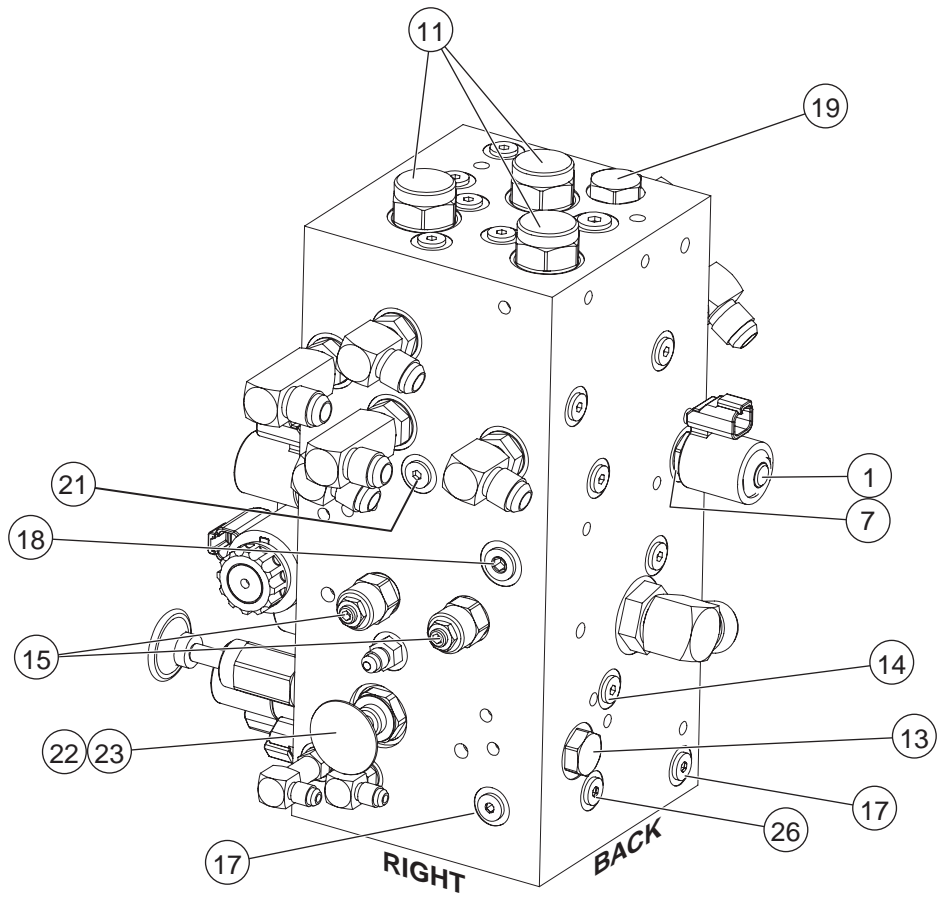

Main Manifold Assembly

ITEM	PART NO.	QTY	DESCRIPTION
–	91140	–	Manifold Assembly
1	91141	4	Coil, Series 8, 12V
2	91142	1	Coil, Series 10, 12V
3	–	–	–
4	91144	1	Valve, Drive, 4 way 3 Position
5	91145	1	Valve, Lift Spool, 3 Way
6	91146	1	Valve, Steer, 4 Way 3 Position
7	91147	2	Valve, Series Parallel Spool, 4 way 3 position
8	–	–	–
9	91149	1	Valve, Relief, Lift
10	91150	1	Valve, relief, Steer
11	91151	3	Valve, Piloted Spool 4 way 3 position
12	91152	2	Valve, Piloted Poppet
13	91153	1	Valve, Load Shuttle Check
14	91154	2	Valve, Load Shuttle Check
15	91350	2	Valve, Counterbalance
16	91353	2	Valve, Check
17	HDW7314	2	Port plug M ¼", O-Ring, RBG-4
	HDW7061	2	Adapter (w/ Outrigger Option)
18	7484	2	Port plug M 0.38" O-Ring, RBG-6
	HDW7438	2	Adapter (w/ Outrigger Option)
19	91351	2	Flow Divider / Combiner
20	91355	1	Orifice Plug, Steer
21	91356	2	Orifice Plug, Flow Divider Bleed
22	91012	1	Valve, Manual — Pull
23	91354	1	Orifice Disc
24	91015	1	Hand Pump, Brake Release
25	91352	1	Pressure Compensator
26	HDW7314	2	Port plug M ¼", O-Ring, RBG-4

... continued

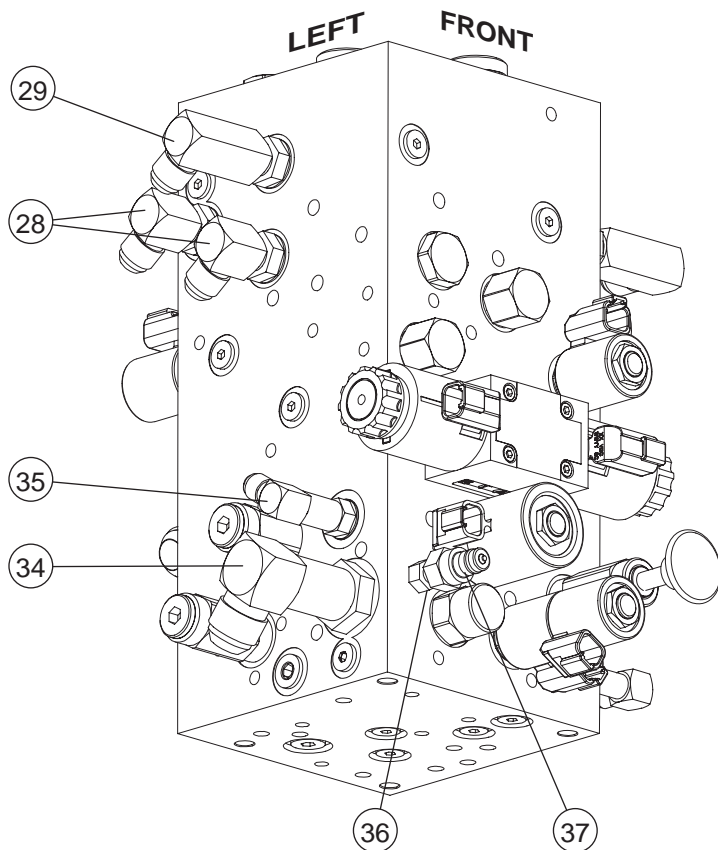
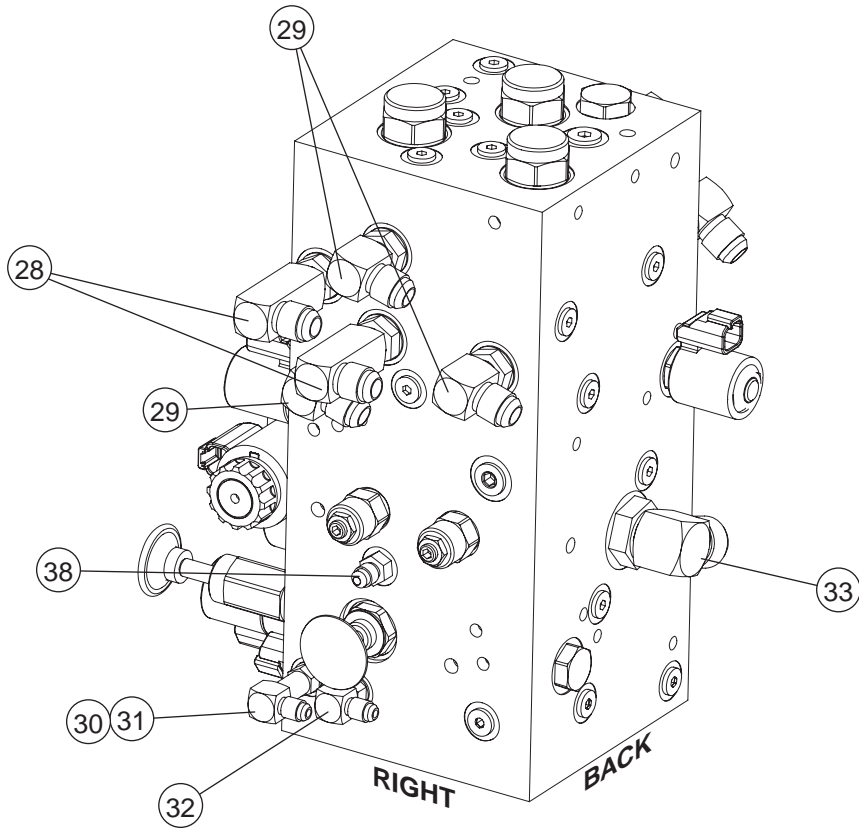

Main Manifold Assembly (continued)

ITEM	PART NO.	QTY	DESCRIPTION
28	HDW91248	3	Elbow, 90°, Male, ½", O-Ring, Male, ½", MB-MJ90LL-8-8
29	HDW90764	5	Elbow, 90°, Male, ½", O-Ring, Male, ½", MB-MJ90-8-8
30	HDW91334	1	Fitting, Orifice 1/16"
31	HDW8877	1	ELBOW, 90°, Male ¼" O-ring, Male ¼", MB-MJ90-4-4
32	HDW91081	1	ELBOW, 90°, Male ¼" O-ring, Male ¼", MB-MJ90LL-4-4
33	HDW91244	1	ELBOW, 90°, Male ¾" O-ring, Male ¾", MB-MJ90-12-12
34	HDW91245	1	ELBOW, 90°, Male ¾" O-ring, Male ¾", MB-MJ90LL-12-12
35	HDW9157	1	Elbow, 90°, Male .37 JIC, Male .37 O-RING, MB-MJ90LL-6-6
36	HDW7971	1	Fitting, Male Disconnect, ¼" NPT
37	HDW91243	1	adapter Male ¼" O-ring Male ¼" NTP, MP-MB-4-4
38	HDW8881	1	Adapter, Male ¼", O-ring, Male ¼" 37° MB-MJ-4-4

• as req: as required

• INCL: Included with assembly

• NS: Not a Stock item

• REF: Reference only



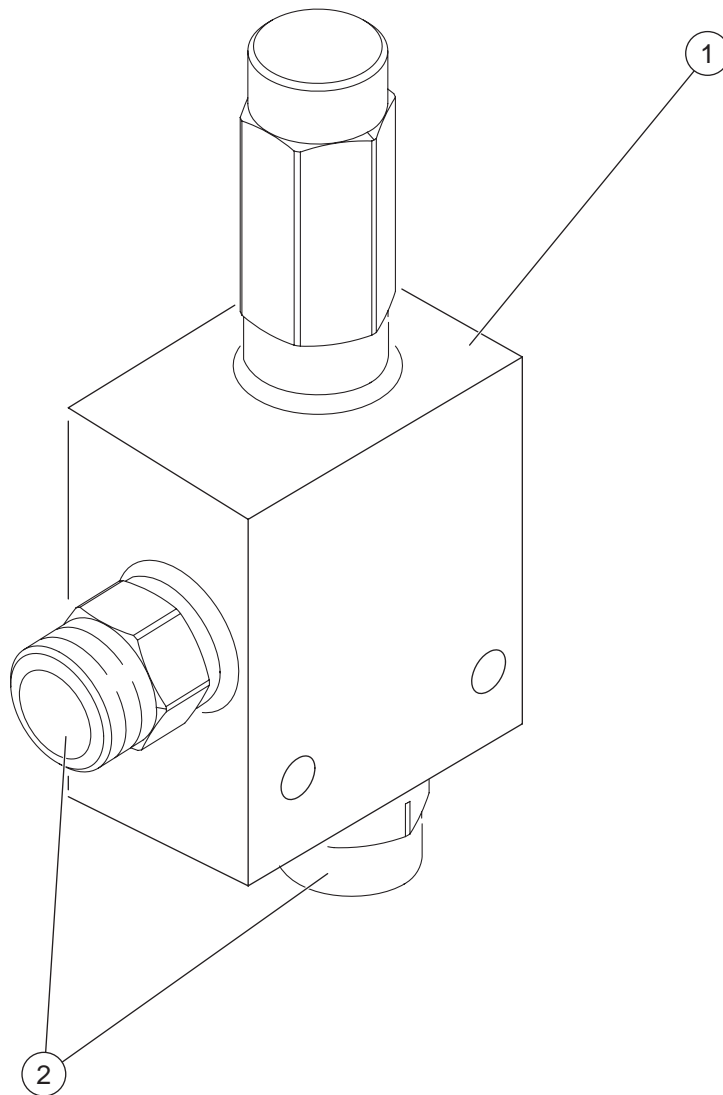

ILLUSTRATION No.
ART_2704

3072ES - 3772ES - 3772ES HD

Main Relief Manifold

Main Relief Manifold Assembly

ITEM	PART NO.	QTY	DESCRIPTION
1	91657	1	Main Relief Valve
2	91716	2	Fitting

• as req: as required

• INCL: Included with assembly

• NS: Not a Stock item

• REF: Reference only



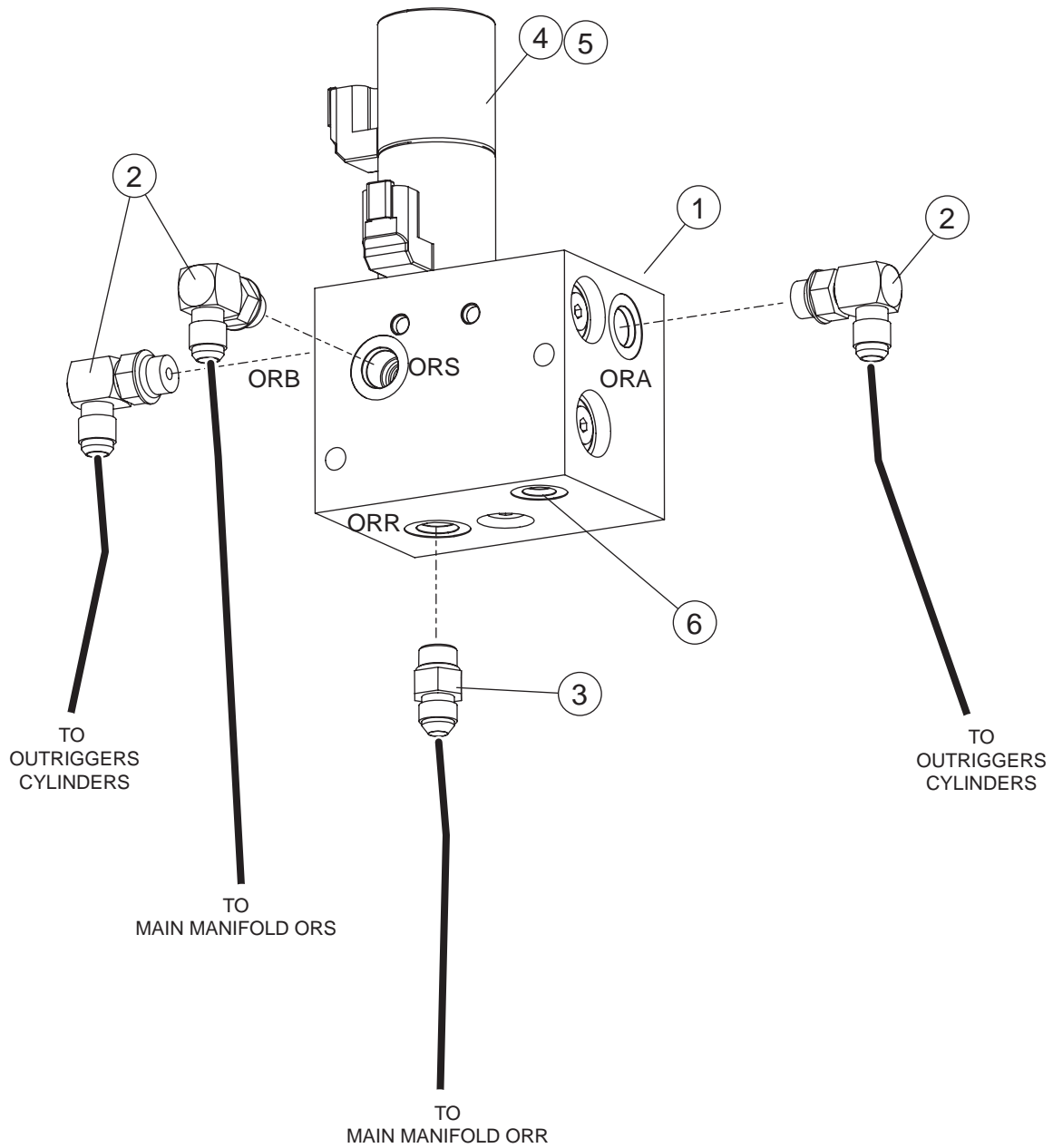
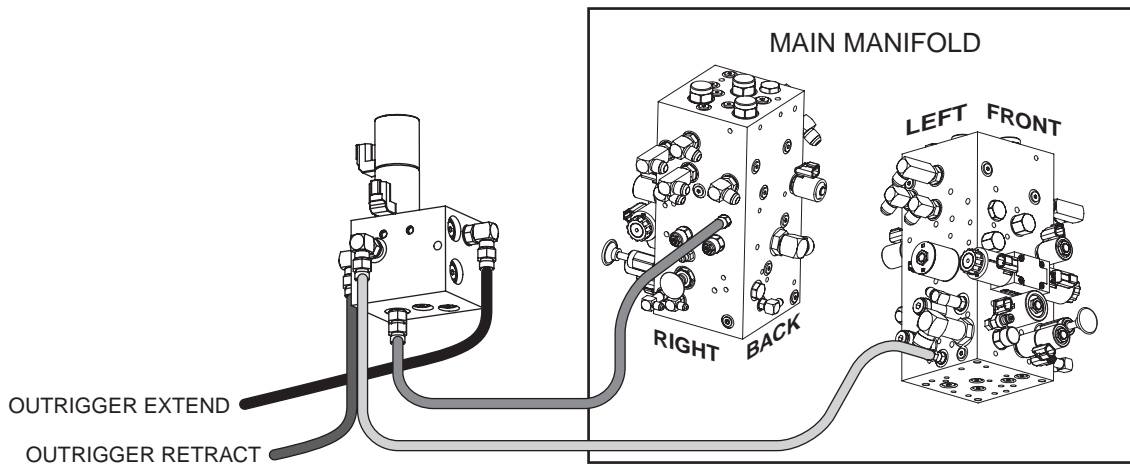

Manifold - Outrigger (HD Models)

ITEM	PART NO.	QTY	DESCRIPTION
1	91721	1	Manifold Assembly
2	HDW7601	3	Elbow 90° Male 3/8" O-ring - Male 3/8" JIC
3	HDW8881	1	Adapter Male 1/4" O-ring - Male 1/4" JIC
4	91142	2	Coil
5	91720	1	Valve Spool 4-way 3-position
6	HDW7314	1	Port Plug

• as req: as required

• INCL: Included with assembly

• NS: Not a Stock item

• REF: Reference only



HD Models: OUTRIGGERS

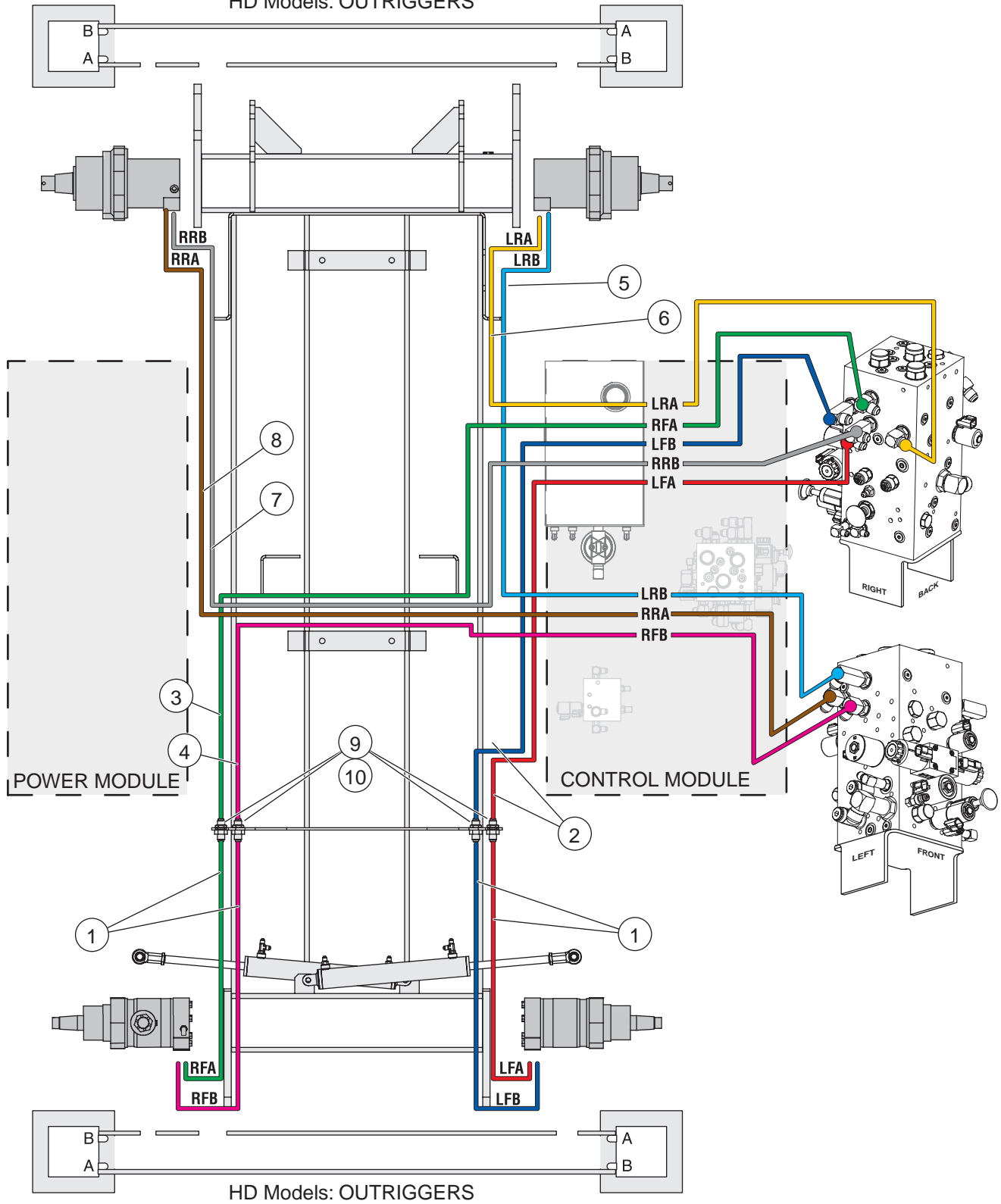

MEC
ILLUSTRATION No.
ART_2706

3072ES - 3772ES - 3772ES HD: Sheet 1 of 4

Hose Kit - Axles

Hydraulic Hoses - Axles

ITEM	PART NO.	QTY	DESCRIPTION
1	91263	4	Hose Assy, 1/2"x37", 8M3K-8FJX-8FJX90S-37"
2	9389	2	Hose Assy, 1/2" x 44", 8M3K-8FJX-8FJX
3	9386	1	Hose Assy, 1/2" x 68", 8M3K-8FJX-8FJX-68"
4	91261	1	Hose Assy, 1/2" x 61", 8M3K-8FJX-8FJX
5	91258	1	Hose Assy, 1/2" x 57", 8M3K-8FJX-8FJX45
6	91257	1	Hose Assy, 1/2" x 49", 8M3K-8FJX-8FJX45
7	91260	1	Hose Assy, 1/2" x 98", 8M3K-8FJX-8FJX45
8	91259	1	Hose Assy, 1/2" x 84", 8M3K-8FJX-8FJX45
9	91192	4	Adapter Male 1/2" JIC - 1/2" JIC Bulkhead
10	91193	4	Jamnut 3/4-16

... continued

• as req: as required

• INCL: Included with assembly

• NS: Not a Stock item

• REF: Reference only



HD Models: OUTRIGGERS

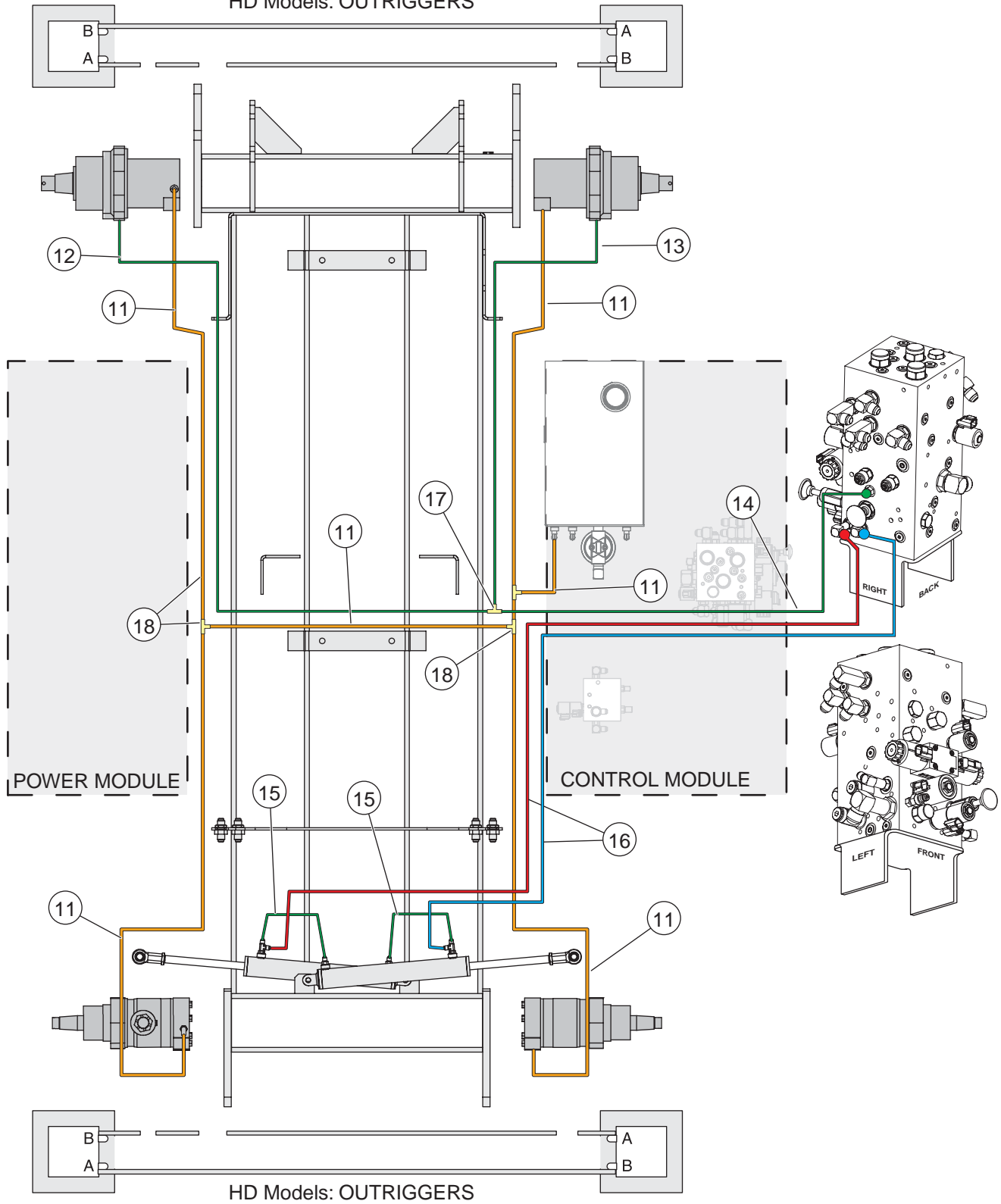

ILLUSTRATION No.
ART_2707

3072ES - 3772ES - 3772ES HD: Sheet 2 of 4

Hose Kit - Steering, Motor Case Drain, Brake

Hydraulic Hoses - Steering, Brake Release and Axle Return

ITEM	PART NO.	QTY	DESCRIPTION
11	6458	as req	Hose, Return Line, Cut to length
12	9227	1	Hose Assy, 1/4"x83", 4G1-4FJX-4FJX90S
13	91256	1	Hose Assy, 1/4"x42", 4G1-4FJX-4FJX90S
14	91255	1	Hose Assy, 1/4" x 15", 90°, 4G1-4FJX-4FJX90S
15	90275	2	Hose Assy, 1/4" x 17", 4G1-4FJX-4FJX
16	91254	2	Hose Assy, 1/4" x 68", 4G1-4FJX-4FJX
17	HDW9557	1	TEE M 0.25 JIC m 0.25 JIC
18	91249	3	TEE M 0.31 HS BR BNN

... continued

• as req: as required

• INCL: Included with assembly

• NS: Not a Stock item

• REF: Reference only



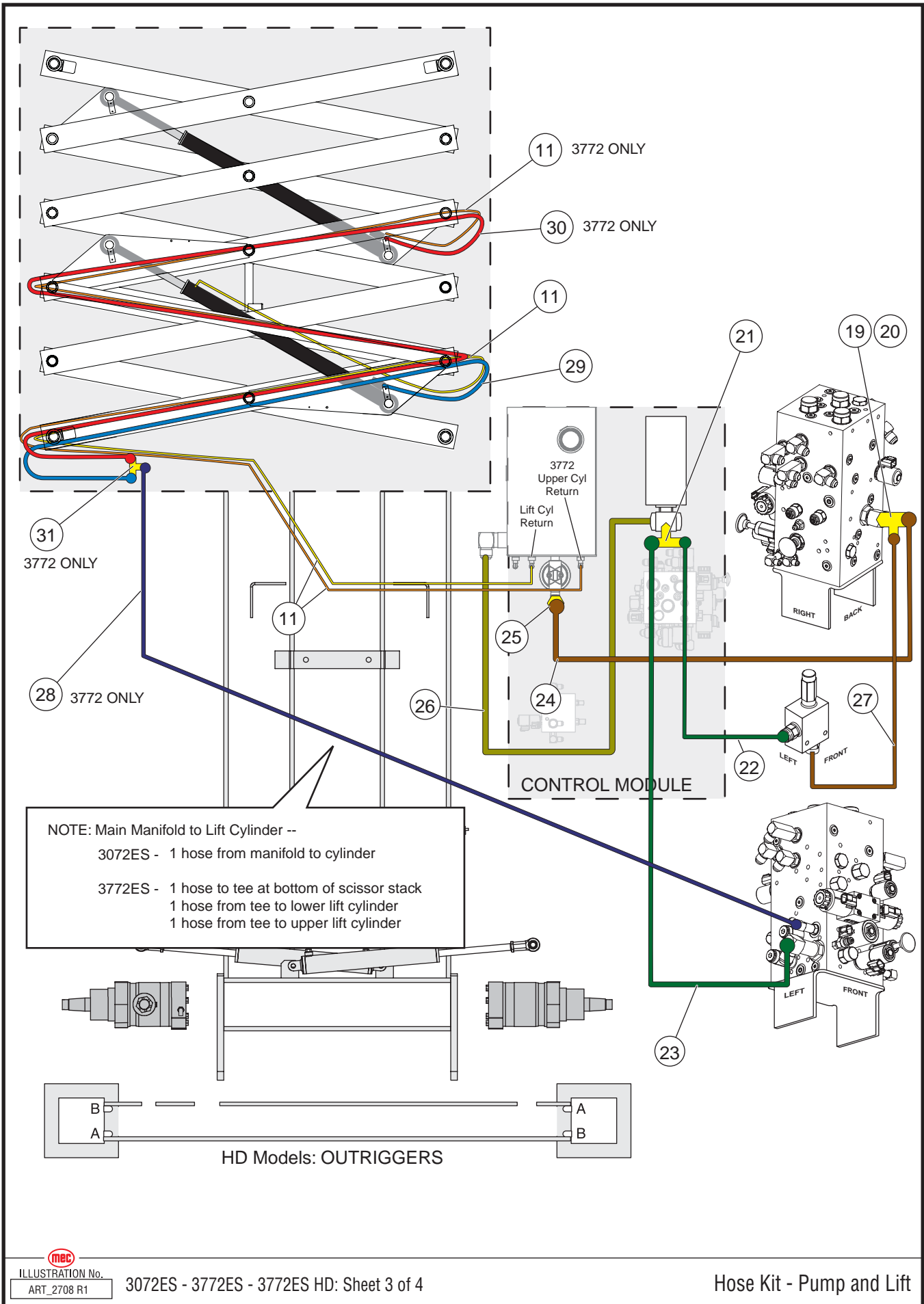

Hydraulic Hoses - Pump and Return

ITEM	PART NO.	QTY	DESCRIPTION
11	6458	as req	Return Line, Cut to Length
19	91466	1	TEE
20	91468	1	Reducer
21	9920	1	TEE
22	90315	1	Hose Assy
23	91698	1	Hose Assy
24	91247	6 FT	Hose Assy, 3/4", 12LOLA bulk
25	HDW91246	2	Fitting Female 3/4" JIC Male 3/4" Hose Barb
26	91265	1	Hose Assy, 1" x 22", (16GMV-16FJX-16FJX-22")
27	23689	1	Hose Assembly
28	9029	1	Hose Assembly, 3772ES Only
29	90985	1	Hose Assembly, 3072ES Lift Cylinder
	9039	1	Hose Assembly, 3772ES Lower Lift Cylinder
30	91719	1	Hose Assembly, 3772ES Upper Lift Cylinder
31	7391	1	TEE, 3772ES Only

... continued

• as req: as required

• INCL: Included with assembly

• NS: Not a Stock item

• REF: Reference only



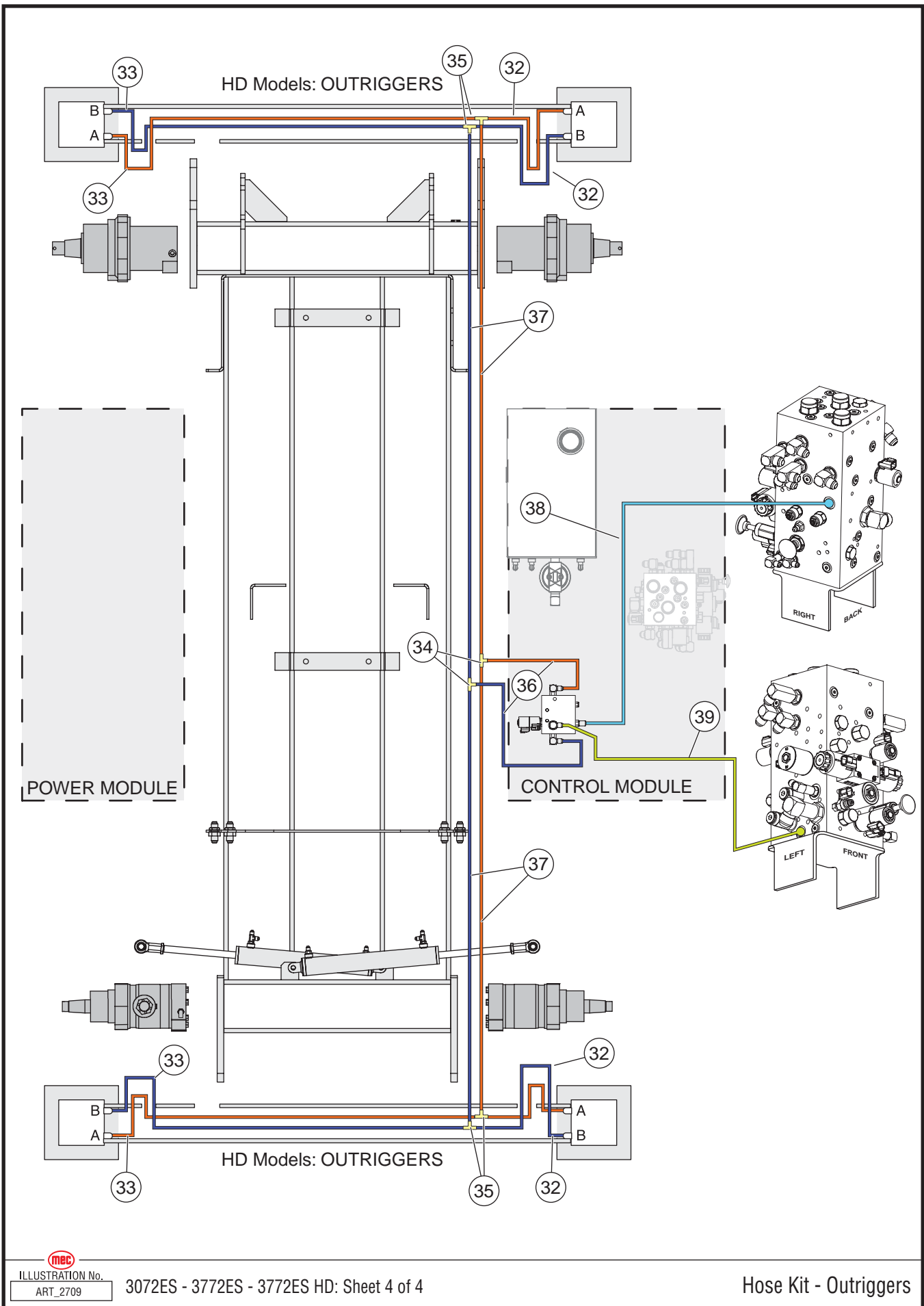

Hydraulic Hoses - Outrigger (HD Models)

ITEM	PART NO.	QTY	DESCRIPTION
32	91346	4	Hose Assy, 1/4"x35" (4G1-4FJX-4FJX90 S)
33	91347	4	Hose Assy, 1/4"x58" (4G1-4FJX-4FJX90 S)
34	HDW7391	2	Tee, Male 3/8" jic
35	HDW9557	4	Tee, Male 1/4" JIC
36	9038	2	Hose Assy, 3/8"x46" (6M3K-6FJX-6FJX)
37	91047	4	Hose Assy, 1/4"x63" (4G1-4FJX-6FJX)
38	7598	1	Hose Assy, 3/8"x28" (6M3K-6FJX-6FJX)
39	8318	1	Hose Assy 3/8"x24" (6M3K-6FJX-6FJX90)

• as req: as required

• INCL: Included with assembly

• NS: Not a Stock item

• REF: Reference only



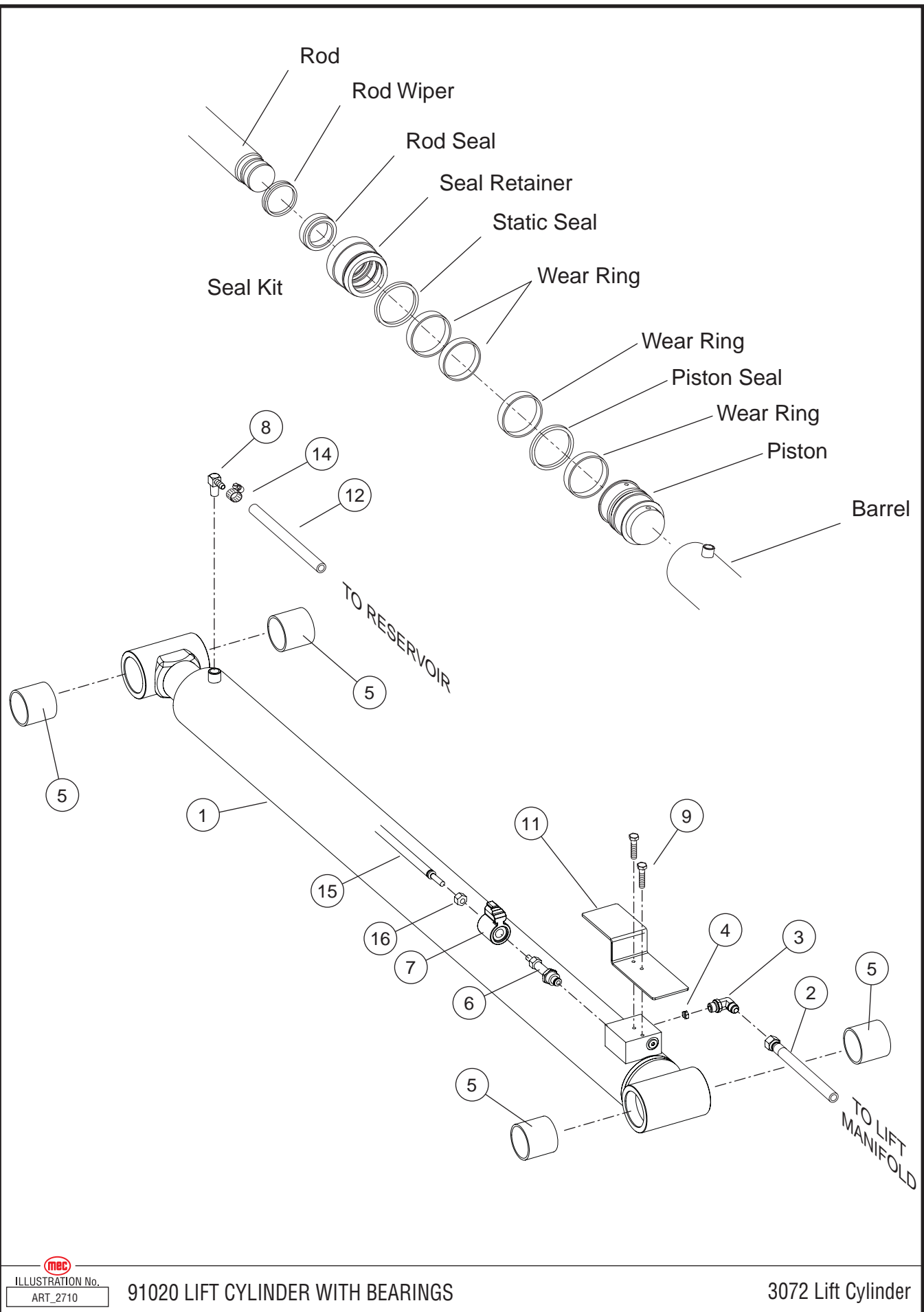

ILLUSTRATION No.
 ART_2710

91020 LIFT CYLINDER WITH BEARINGS

3072 Lift Cylinder

Lift Cylinder, 3072

ITEM	PART NO.	QTY	DESCRIPTION
1	91020	1	Cylinder, Lift 3072RT
2	90985	1	Hose Assembly, 3/8"
3	HDW7601	1	Fitting, Elbow Adaptor
4	91804	1	Orifice, 0.042
5	6669	4	Bearing, 2" ID x 2" LG
6	91051	1	Valve, 2 Way, N.C. Cable Attach
7	91141	1	Coil, 12 Volt, Deutsch
8	HDW6727	1	Fitting, Pipe 90°, Male Barb
9	HDW8152	2	SCREW, 1/4" - 20 x 3/4" LG
10	-	-	-
11	16062	1	Bracket, Lift Cylinder Valve Guard
12	6458	21 FT	Hose, Return Line
13	-	-	-
14	7788	1	Clamp, Hose
15	91182	1	Cable, E-Down
16	HDW91240	1	Nut, Coupling 10-32 x 3/4"
-	91460	REF	Kit, Seal-Lift Cylinder (service)

• as req: as required

• INCL: Included with assembly

• NS: Not a Stock item

• REF: Reference only



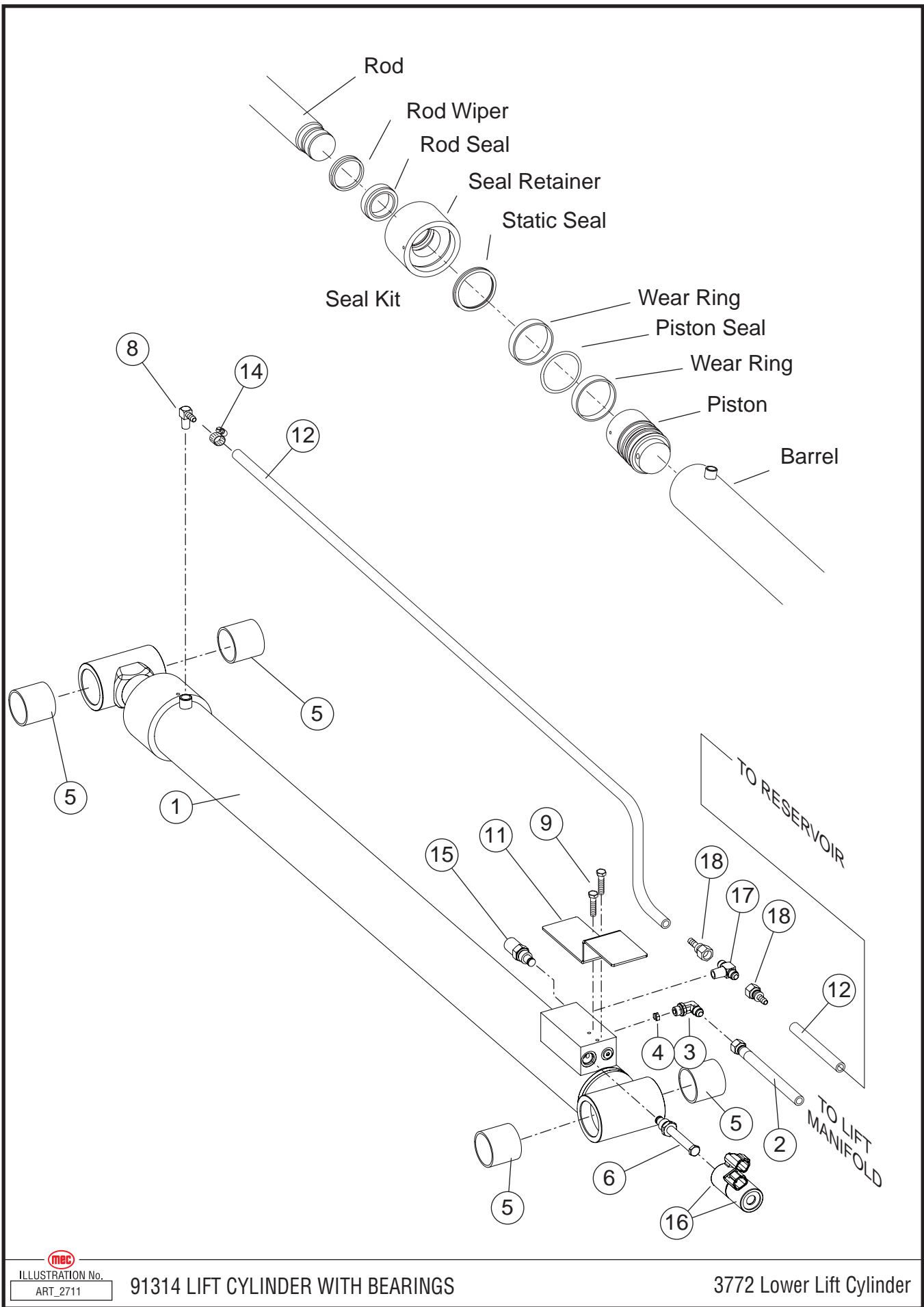



 ILLUSTRATION No.
 ART_2711

91314 LIFT CYLINDER WITH BEARINGS

3772 Lower Lift Cylinder

Lift Cylinder, Lower, 3772

ITEM	PART NO.	QTY	DESCRIPTION
1	91314	1	Cylinder, Lower lift, 3772RT
2	9039	1	Hose Assembly, Lift Cylinder 3/8"
3	HDW7601	1	Fitting, Elbow 90°, .37JIC × 37 O-ring
4	91804	1	Orifice, 0.042
5	90993	4	Bearing, Bronze, 2" ID × 2" LG
6	91462	1	Valve, 2 Way, N.C. Poppet Dual Coil
7	-	-	-
8	HDW6727	1	Fitting, Pipe 90°, Male Barb
9	HDW8152	2	Screw, 1/4" - 20 × 3/4" LG
10	-	-	-
11	16062	1	Bracket, Lift Cylinder Valve Guard
12	6458	21 FT	Hose, Return Line
13	-	-	-
14	7788	1	Clamp, Hose, 5/8 Max
15	90969	1	Relief Valve
16	91141	2	COIL, 12 VOLT, Deutsch Connector w/Diode
17	HDW90943	1	Fitting, TEE Adaptor
18	HDW90945	2	Fitting, Female Swivel
-	90988	REF	Kit, Seal-Lift Cylinder - Lower (Service)

• as req: as required

• INCL: Included with assembly

• NS: Not a Stock item

• REF: Reference only



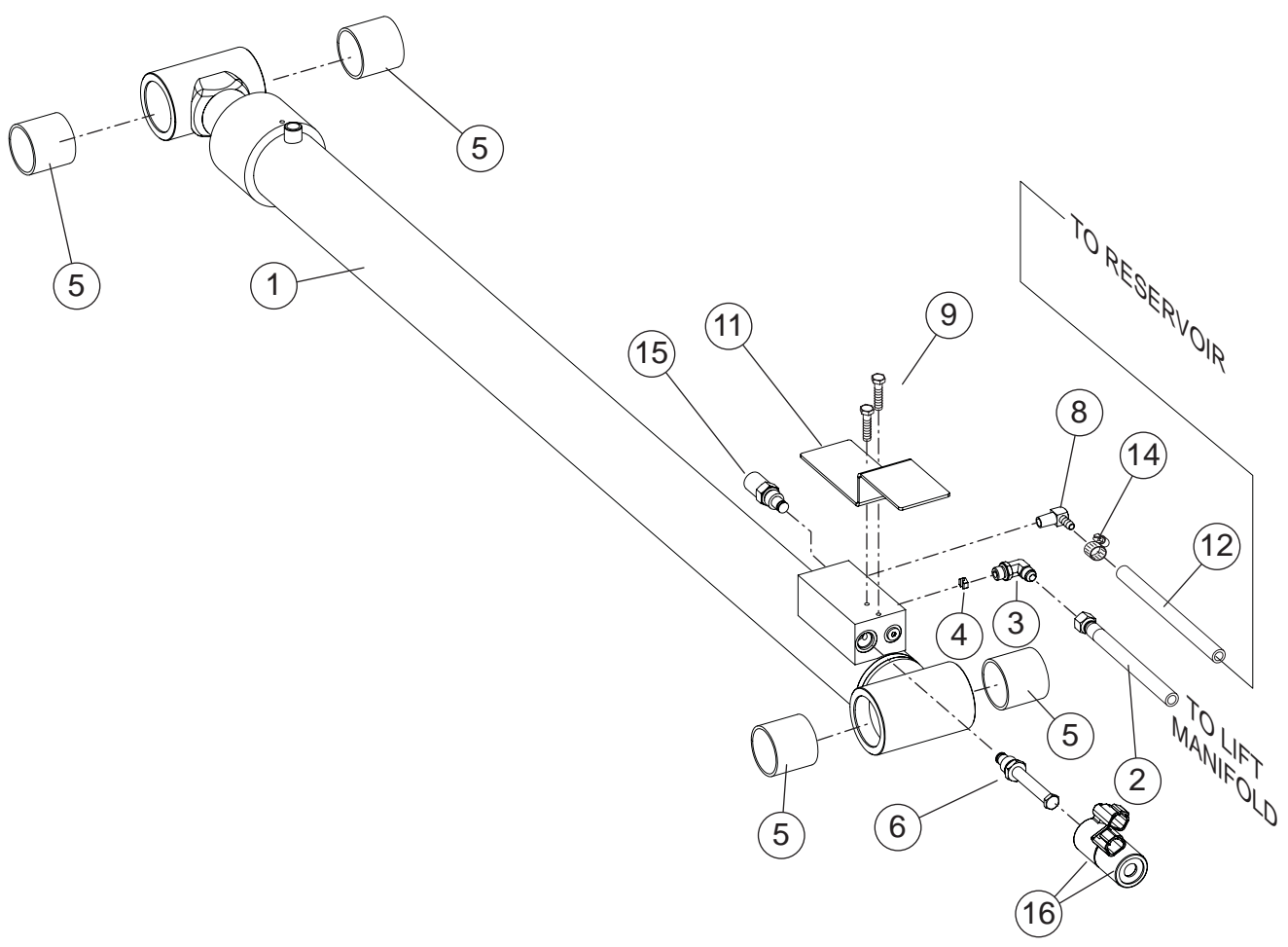
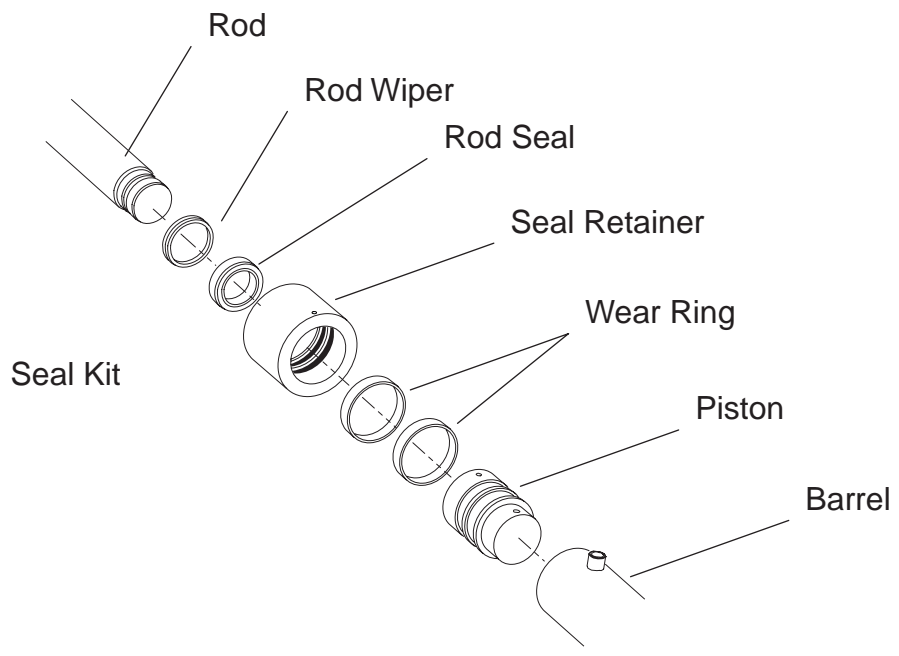

Lift Cylinder, Upper, 3772

ITEM	PART NO.	QTY	DESCRIPTION
1	91315	1	Cylinder, Upper Lift, 3772RT
2	91377	1	Hose Assembly, Lift Cylinder 3/8" x 370"
3	HDW7601	1	Fitting, Elbow Adaptor
4	91805	1	Orifice, 0.067
5	90993	4	Bearing, Bronze, 2" ID x 2" LG
6	91462	1	Valve, 2 Way, N.C. Dual Coil
7	-	-	-
8	HDW6727	1	Fitting, Pipe 90°, Male Barb
9	HDW8152	2	Screw, 1/4" - 20 x 3/4" LG
10	-	-	-
11	16062	1	BRacket, Lift Cylinder Valve Guard
12	6458	40 FT	Hose, 5/16", Return Line
13	-	-	-
14	7788	1	Clamp, Hose
15	90969	1	RELief Valve
16	91141	2	Coil, 12 Volt, Deutsch Connector w/Diode
-	90987	REF	Kit, Seal-lift Cylinder (Service)

• as req: as required

• INCL: Included with assembly

• NS: Not a Stock item

• REF: Reference only



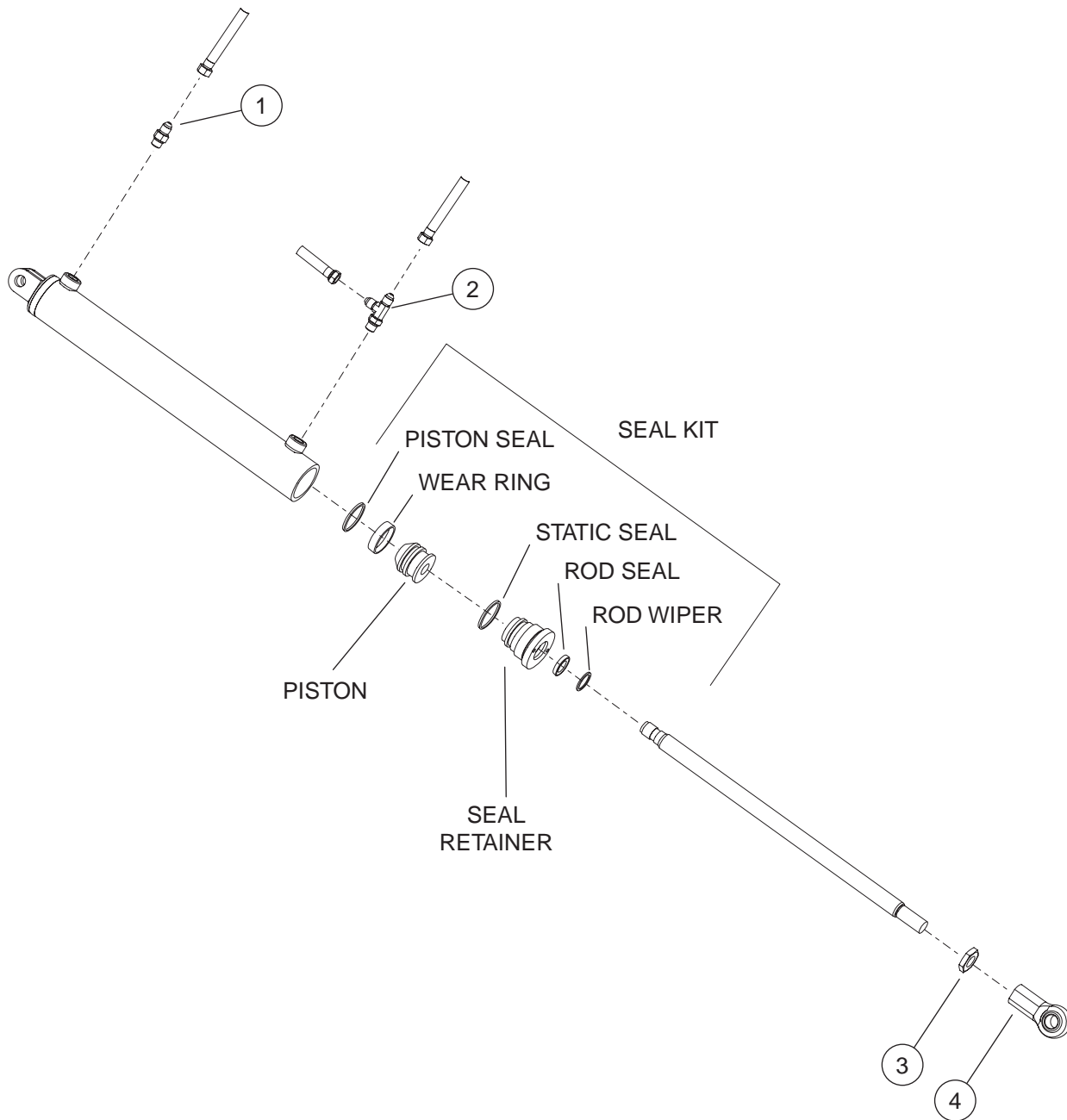

 ILLUSTRATION No.
ART_2713

91019 Steering Cylinder

X72 Steering Cylinder

Steering Cylinder

ITEM	PART NO.	QTY	DESCRIPTION
-	91019	2	Steering Cylinder
1	HDW8881	1	Adapter Male 1/4" O-Ring-Male 1/4" JIC
2	HDW8876	1	Adapter Male 1/4 O-Ring-Male 1/4" JIC TEE
3	HDW5925	1	Jamnut 5/8-18
4	7293	1	Rod End
-	90990	REF	Seal Kit (Service)

• as req: as required

• INCL: Included with assembly

• NS: Not a Stock item

• REF: Reference only



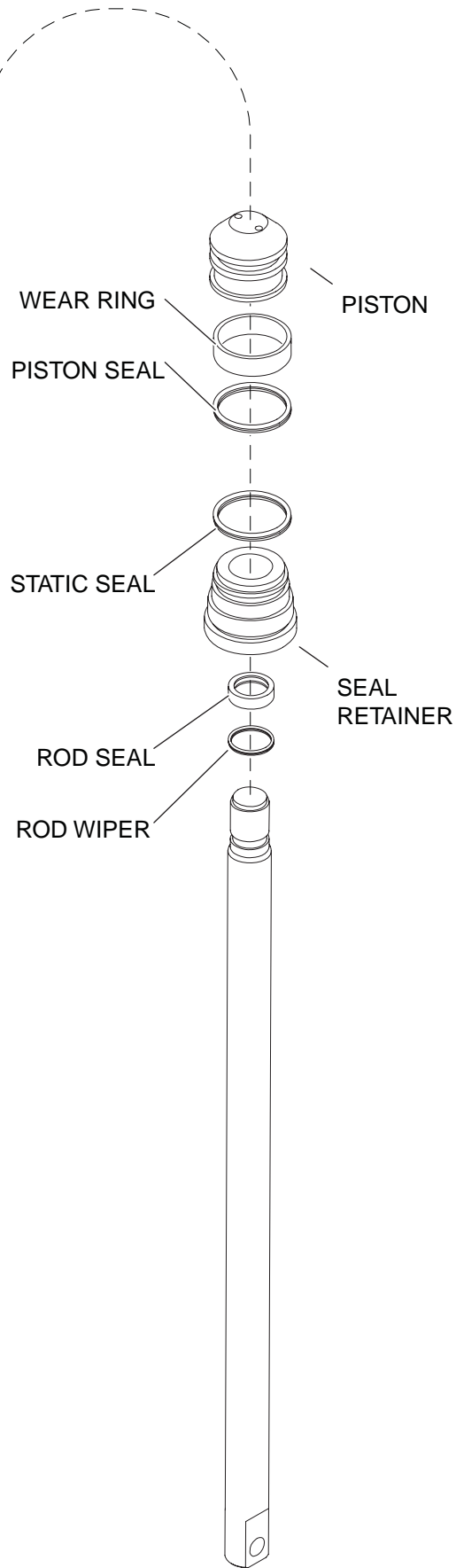
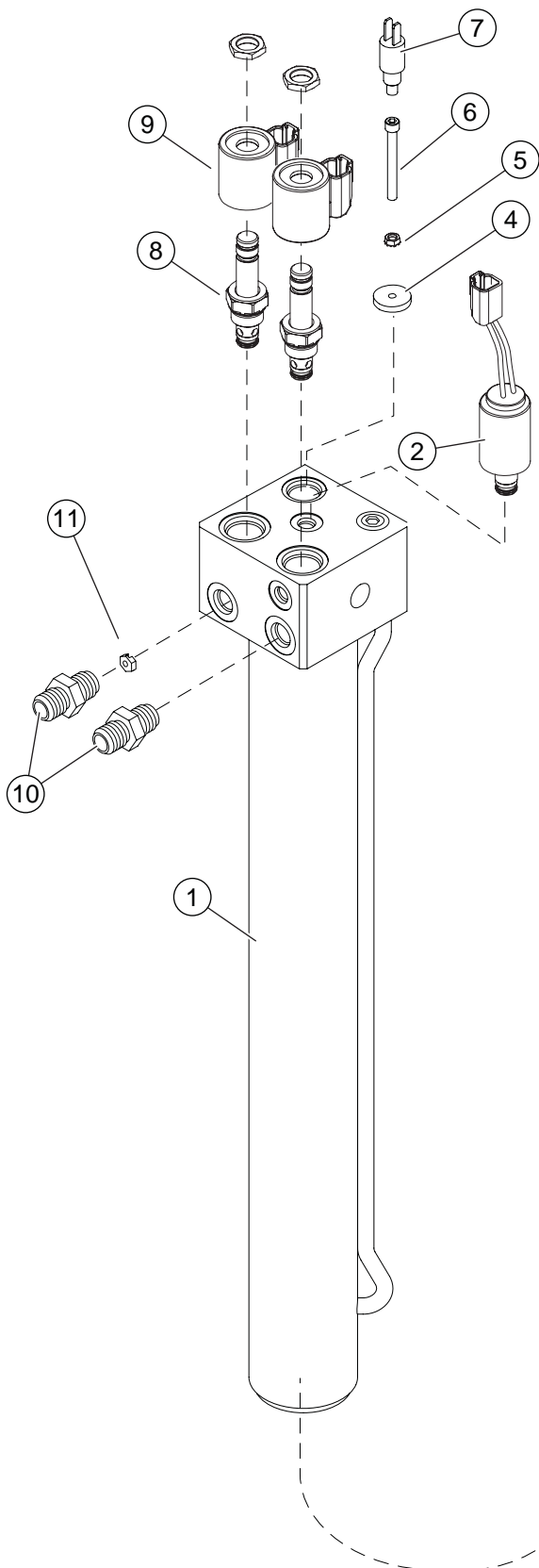

WEAR RING

PISTON SEAL

STATIC SEAL

SEAL RETAINER

ROD SEAL

ROD WIPER

PISTON



ILLUSTRATION No.
ART_2714

91278 Cylinder Assembly

Outrigger Cylinder

Outrigger Cylinder

ITEM	PART NO.	QTY	DESCRIPTION
1	91278	4	Cylinder, Outrigger
2	91281	1	Switch, Outrigger Pressure N.O.
3	-	-	-
4	10907	1	Washer Actuator
5	HDW8476	1	Nut Jam ¼-20
6	HDW9761	1	Screw, Socket Head ¼-20 × 2½
7	91277	1	Switch, Outrigger Retract Limit N.O.
8	91464	2	Valve N.C. Poppet
9	91141	2	Coil 12V Deutsch
10	HDW91465	2	Adapter 3/8 Male O-Ring, ¼ Male JIC
11	90439	1	Orifice
-	91463	REF	Seal Kit

• as req: as required

• INCL: Included with assembly

• NS: Not a Stock item

• REF: Reference only



NOTES:



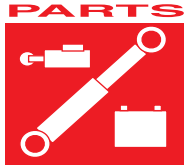



SECTION F

BASE

CONTENTS	PAGE
Base Assembly	F-3
Ballast (Counterweight) Installation	F-5
Modules Installation	F-7
Control Module	F-9
Control Module (continued)	F-11
Power Module	F-13
Wire Harness	F-15
Outrigger Installation (3772ES HD)	F-17

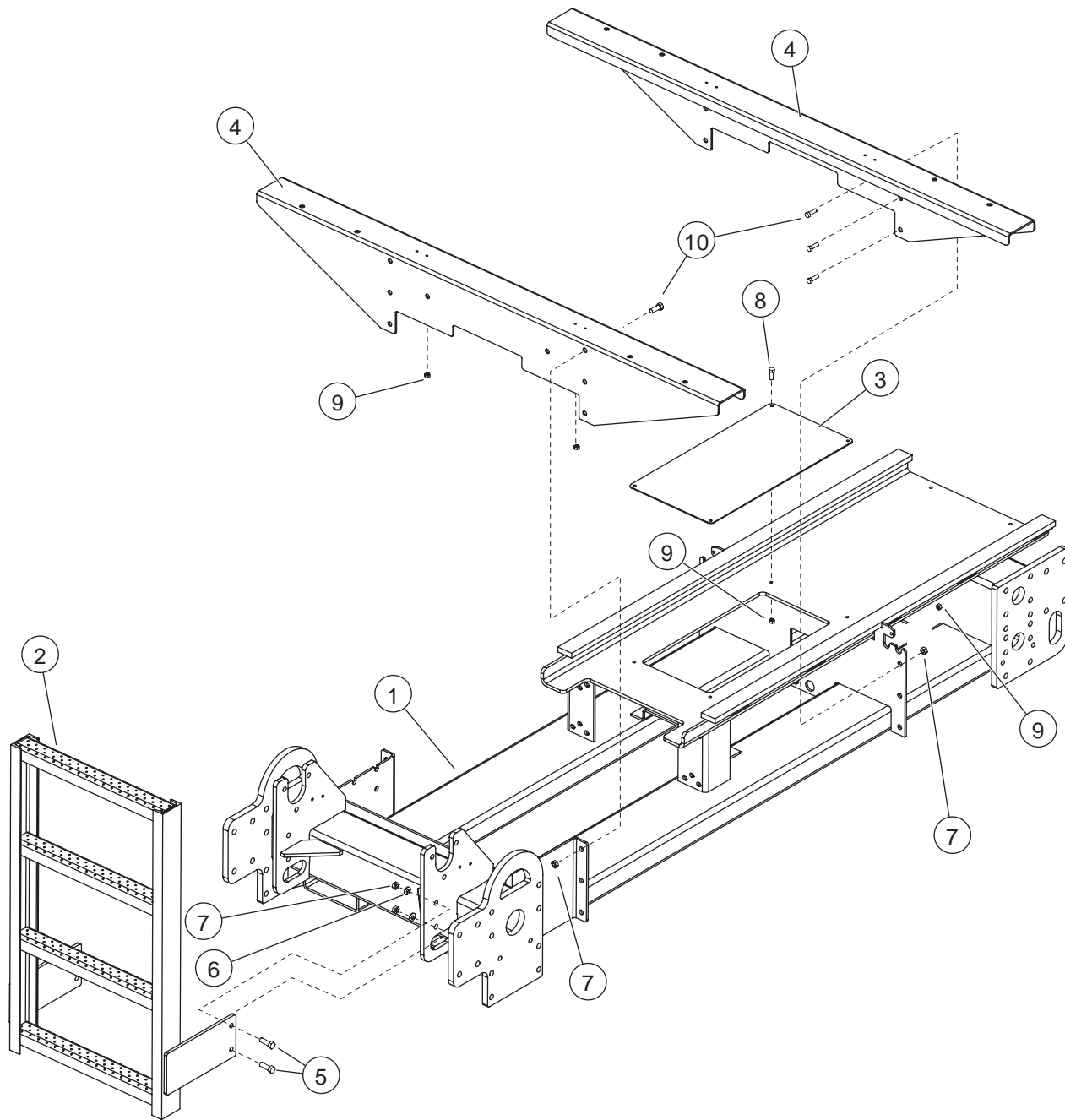



 ILLUSTRATION No. 3072 - 3772
ART_2715

Base Assembly

Base Assembly

ITEM	PART NO.	QTY	DESCRIPTION
1	40159	1	Base Weldment
2	16160	1	Ladder Weldment, 3072RT Standard
	16293		Ladder Weldment, 3772RT Standard
3	16206	1	Cover, Slider Pan
4	14993	2	Support, Module
5	HDW8283	16	Screw, 1/2" - 13, 1 1/2" LG. GR8
6	HDW8531	4	Washer, .531 ID x 1.0 OD x .063 THK
7	HDW8457	16	Nut, 1/2" - 13, GR 5
8	HDW5723	12	Screw, 1/4-12 x 3/4"
9	HDW8267	12	Nut, 1/4-20

• as req: as required

• INCL: Included with assembly

• NS: Not a Stock item

• REF: Reference only



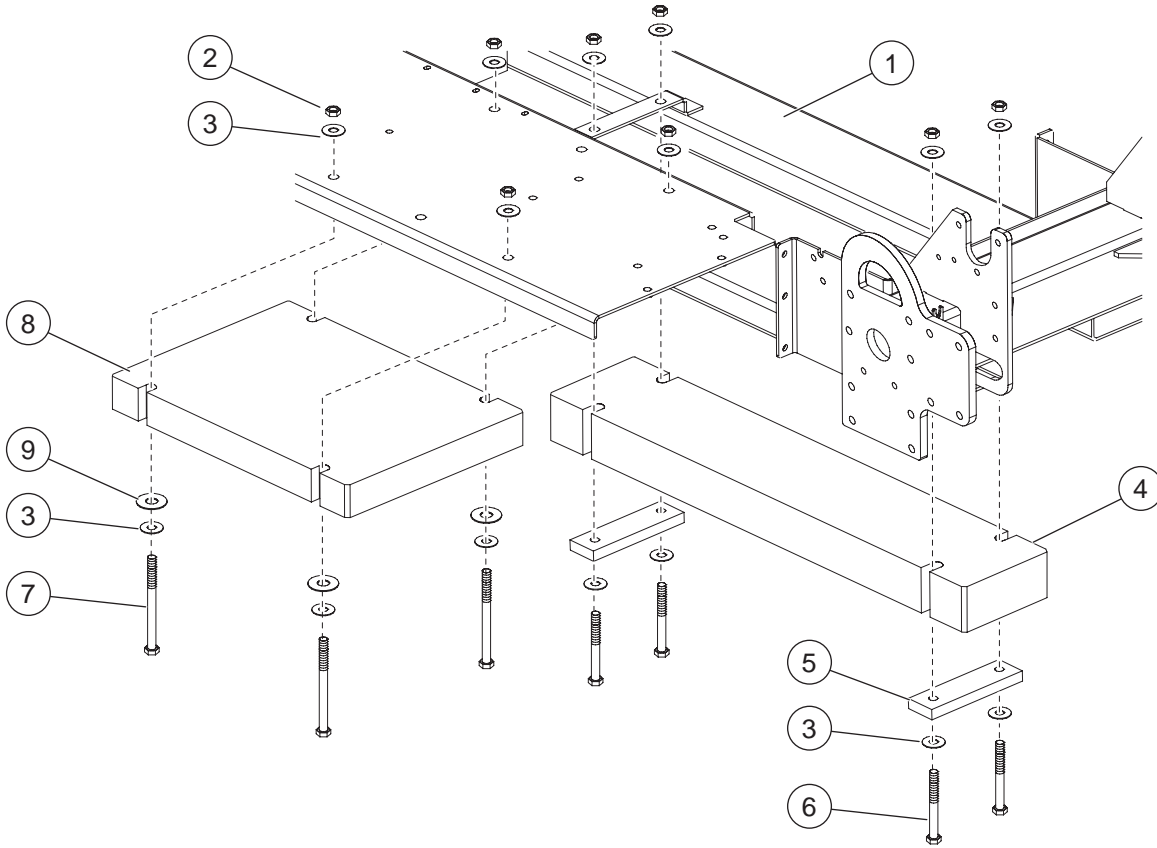

3072

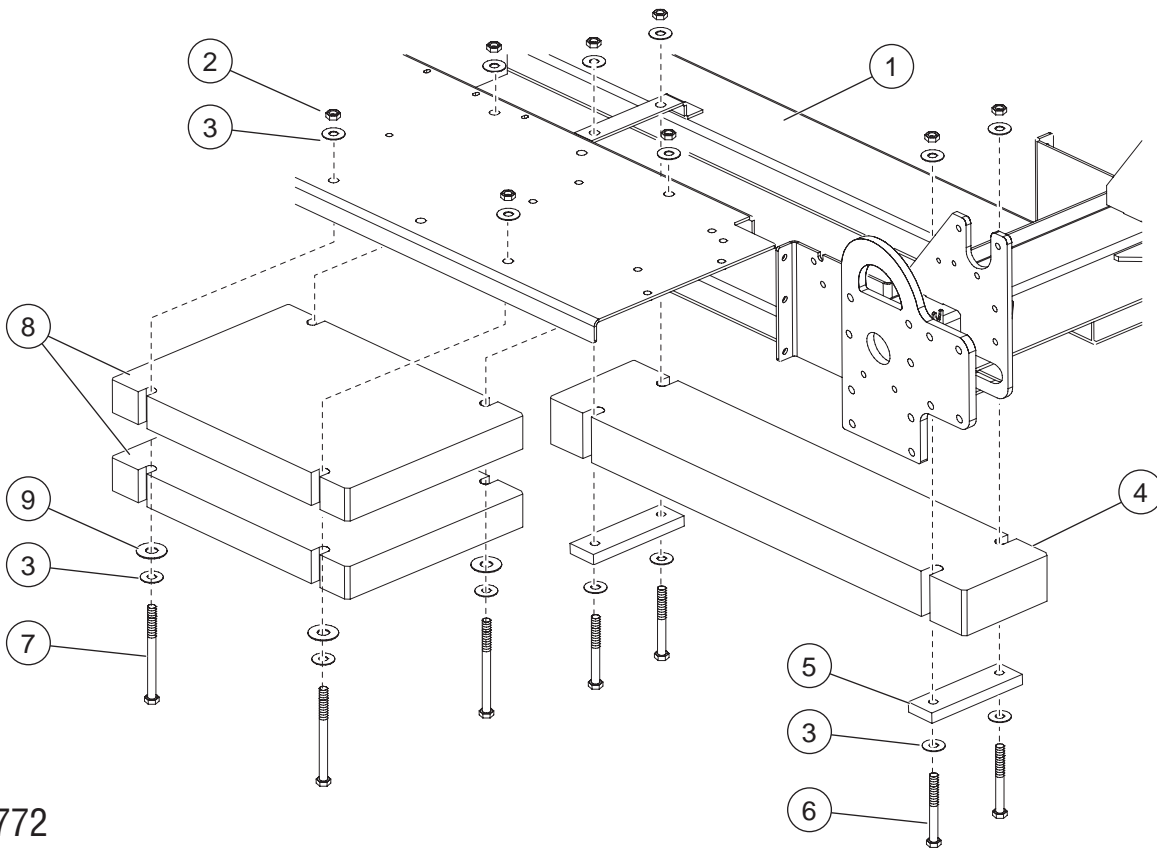

3772

 ILLUSTRATION No. 3072 - 3772
ART_2716

Ballast

Ballast (Counterweight) Installation

ITEM	PART NO.	QTY	DESCRIPTION
1	40159	1	Base Weldment
2	HDW8457	8	Nut, Lock, ½"-13, GR 5
3	HDW13195	8	Washer, Flat, .515 ID × 1.512 OD × .098 THK
4	40590	1	Bar, Ballast Weight
5	16736	2	Bar, Counterweight Retainer
6	HDW90951	4	Screw, ½"-13, 6" LG, GR 5
7	HDW7018	4	Screw, ½"-13, 3" LG, GR 5
8	16368	1	Plate, Ballast Weight 3072RT
	16368	2	Plate, Ballast Weight 3772RT
9	HDW13195	4	Washer, Flat

• as req: as required

• INCL: Included with assembly

• NS: Not a Stock item

• REF: Reference only



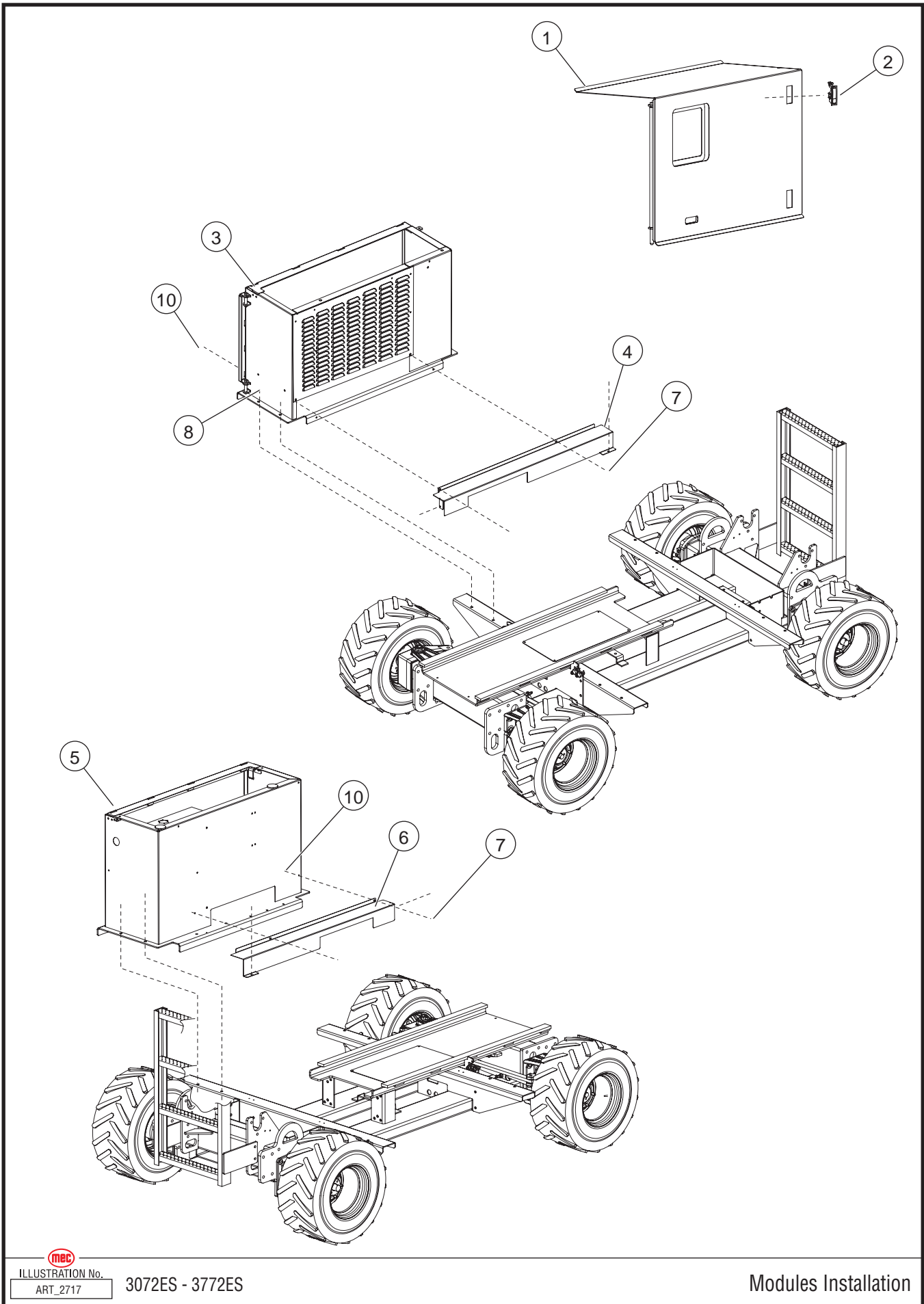

ILLUSTRATION No.
ART_2717

3072ES - 3772ES

Modules Installation

Modules Installation

ITEM	PART NO.	QTY	DESCRIPTION
1	16985	1	Door Weldment, Control Module
	16984	1	Door Weldment, Power Module (Not Shown)
2	8386	4	Latch Trigger
3	84077	1	Weldment, Power Module
4	16165	1	Cover, Hose Tray, LH 3072RT
	16313	1	Cover, Hose Tray, LH 3772RT
5	16153	1	Weldment, Control Module
6	16164	1	Cover, Hose RH
7	HDW5723	8	Bolt, 1/4"-20, 3/4" LG, GR 5
8	HDW5417	8	Screw, 3/8"-16, 1.25" LG, GR 8
9	HDW5355	8	Washer, .438 ID x 1.000 OD x .078 THK
10	HDW8267	8	Nut, 1/4-20

• as req: as required

• INCL: Included with assembly

• NS: Not a Stock item

• REF: Reference only



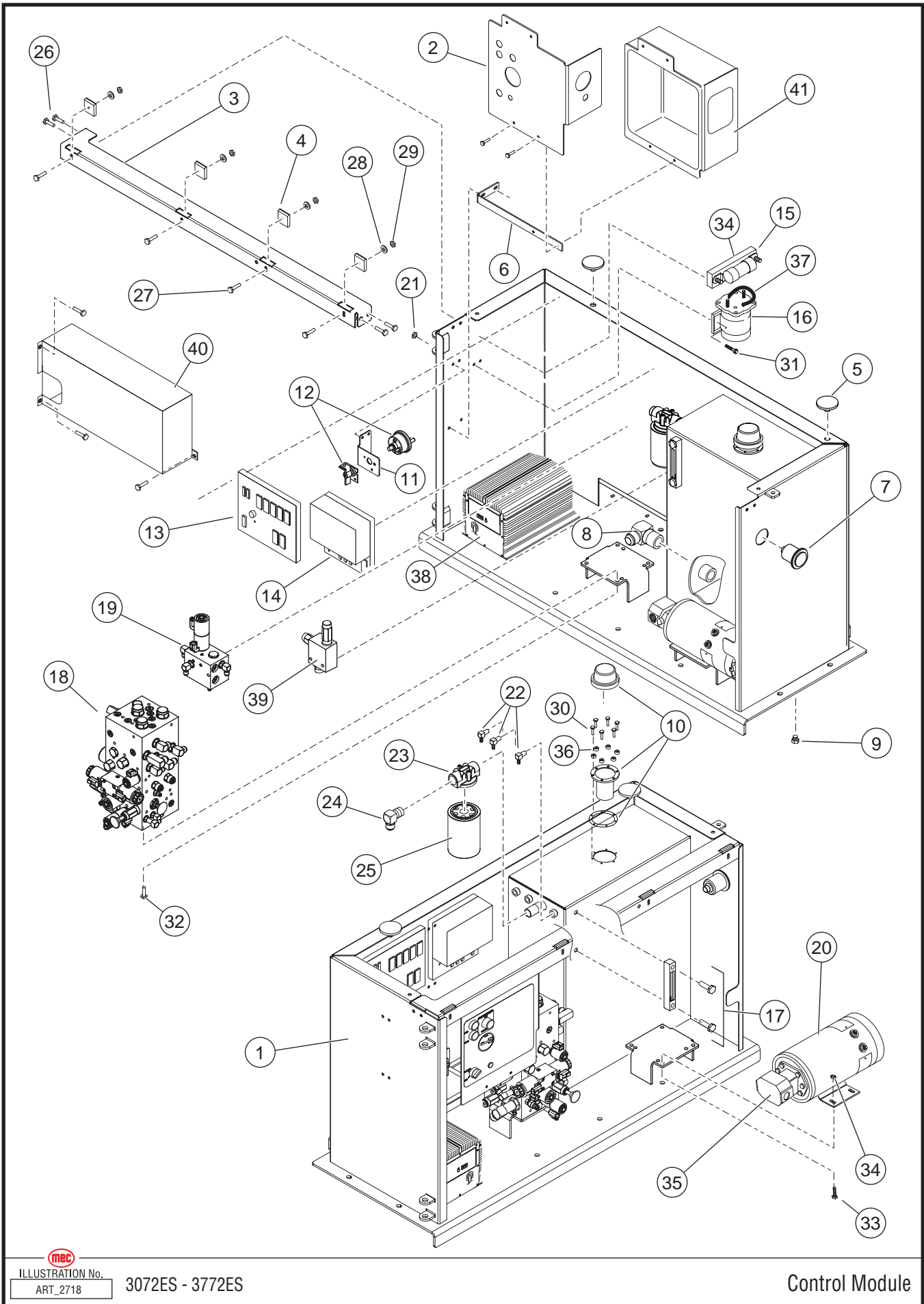

MEC
ILLUSTRATION No.
ART_2718

3072ES - 3772ES

Control Module

Control Module

ITEM	PART NO.	QTY	DESCRIPTION
1	ref	–	Control Module Weldment
2	83050	1	Control Panel
3	16154	1	Bracket, Cross Support
4	14896	4	Block, Slide, Door
5	25429	2	Pad
6	16226	1	Bracket, Control Panel
7	90749	1	Plug, Power to Platform
8	91748	1	Fitting, 1 1/8–3/4 Male JIC
9	HDW9200	1	Plug, 1/4 NPT
10	9367	1	Filler/Strainer
11	16229	1	Bracket, Battery Disconnect
12	8841	1	Switch, Battery Disconnect
13	91659	1	System Controller, GP400
14	91658	1	Motor Controller
15	91709	1	Fuse, 300 AMP
16	91745	1	Contact, Solenoid 48V, 12V Coil
17	9370	1	Level Gauge
18	91140	1	Hydraulic Manifold
19	91721	1	Outrigger Manifold (HD Models)
20	91640	1	Electric Motor
21	8267	2	Nut, 1/4–20
22	6727	3	Fitting
23	6714	1	Filter Head
24	HDW9268	1	Elbow, 90° 3/4 NPT – 3/4 JIC
25	6156	1	Filter Cartridge
26	HDW5724	4	Screw, 5/16–18 x 3/4, GR5
27	HDW8273	4	Screw, 1/4–20 x 1
28	HDW5217	4	Washer, .3431D x .6800D x .063THK
29	HDW8267	4	Nut, 1/4–20, GR5
30	HDW8482	6	Bolt, 32 x 1.57

... continued

• as req: as required

• INCL: Included with assembly

• NS: Not a Stock item

• REF: Reference only



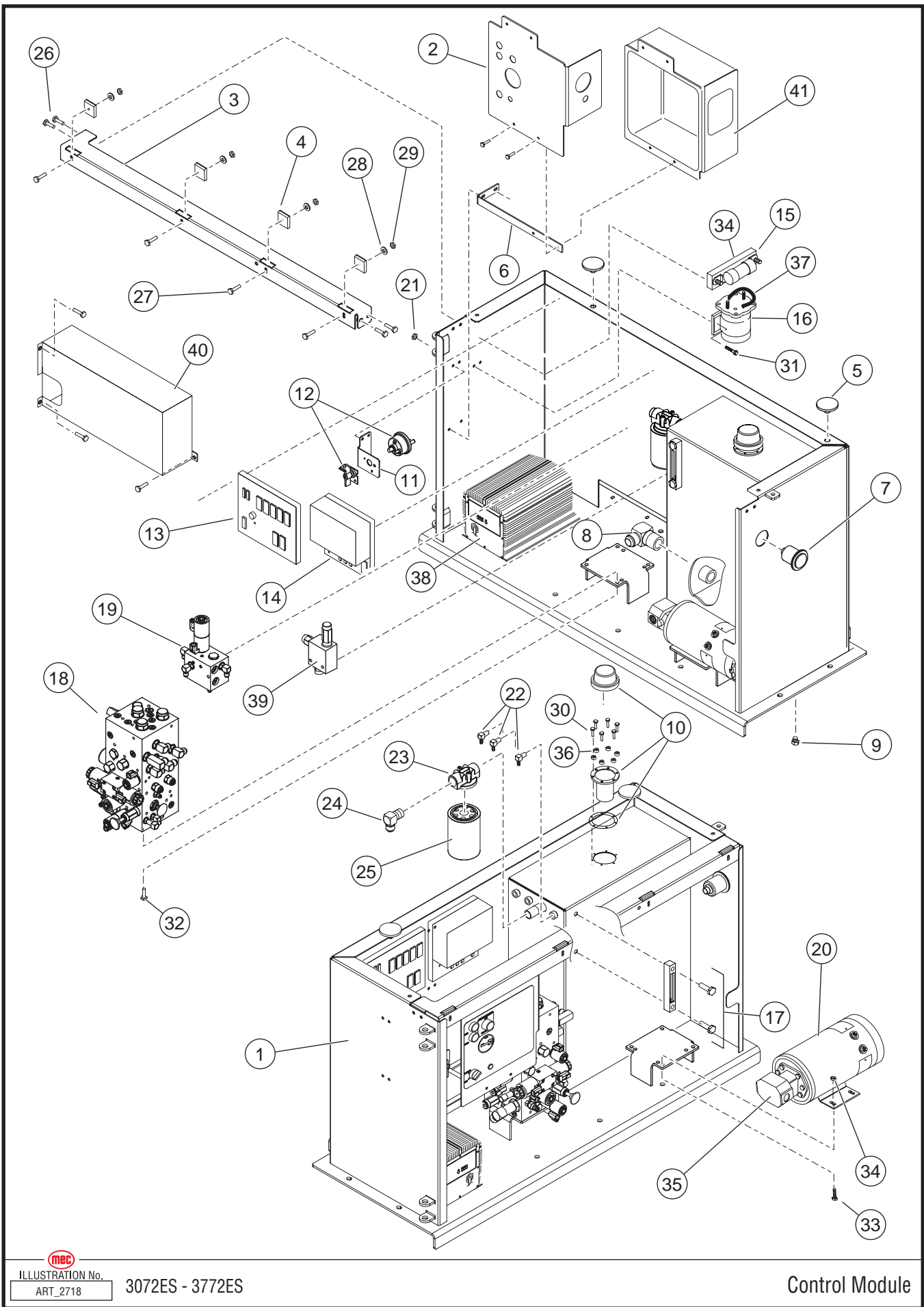

MEC
ILLUSTRATION No.
ART_2718

3072ES - 3772ES

Control Module

Control Module (continued)

ITEM	PART NO.	QTY	DESCRIPTION
31	5904	2	Bolt
32	HDW6433	4	Screw, 3/8 × 1
33	8273	4	Screw, 1/4-20 × 1
34	HDW8267	4	Nut, 1/4-20
35	91673	1	Pump, 10CC
36	HDW91267	6	Rivet Nut
37	8368	1	Diode
38	91655	1	Battery Charger
39	91657	1	Manifold, Main Relief
40	16995	1	Cover
41	16995	1	Cover

• as req: as required

• INCL: Included with assembly

• NS: Not a Stock item

• REF: Reference only



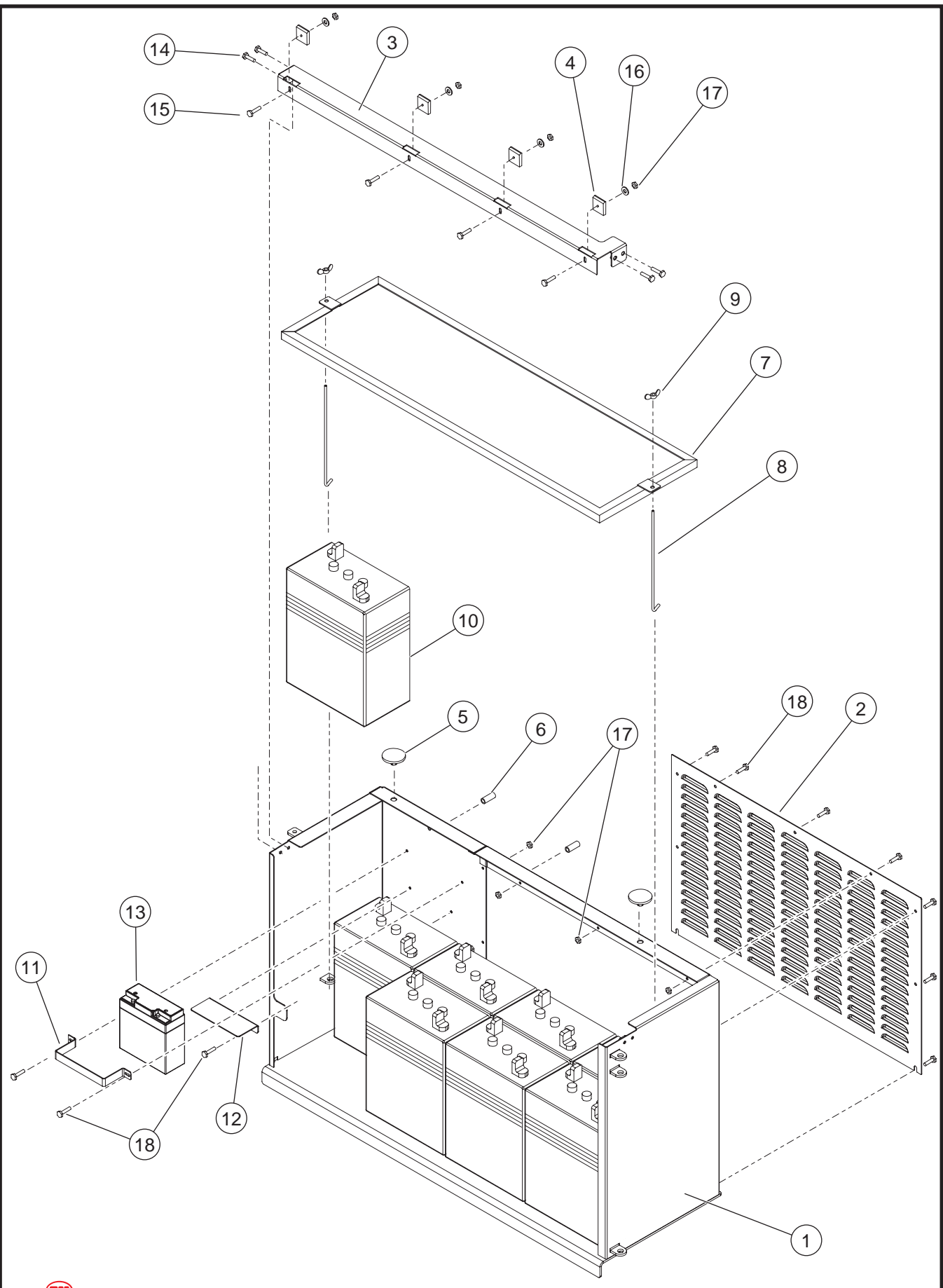

 ILLUSTRATION No. 3072ES - 3772ES
 ART_2719

Power Module

Power Module

ITEM	PART NO.	QTY	DESCRIPTION
1	REF	–	Weldment, Battery Module
2	16974	1	Panel, Battery Module
3	40826	1	Channel, Battery Module
4	14896	4	Block, Slide, Door
5	25429	2	Pad
6	40620	2	Spacer, Insulator, 1.59" LG
7	16983	1	Battery Holddown
8	2987	2	Holddown Rod
9	6110	2	Wingnut
10	91641	8	Battery, 375 AH, UL16
11	16619	1	Bracket, Battery
12	16620	1	Shelf, Battery
13	90898	1	Battery, 12VDC / 17-18 AH
14	HDW5724	4	Screw, 5/16–18, 3/4" LG, GR 5
15	HDW8273	4	Screw, 1/4–20, 1" LG
16	HDW5217	4	Washer, .343 id x .680 od x .063 THK
17	HDW8267	4	Nut, 1/4–20, GR 5
18	HDW5723	10	Screw, 1/4–20 x 3/4

• as req: as required

• INCL: Included with assembly

• NS: Not a Stock item

• REF: Reference only



UPPER CONTROLS

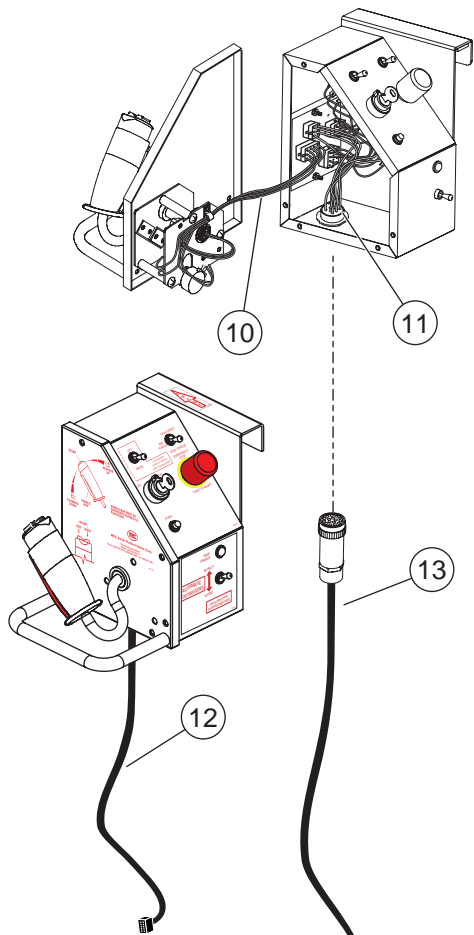

POWER MODULE

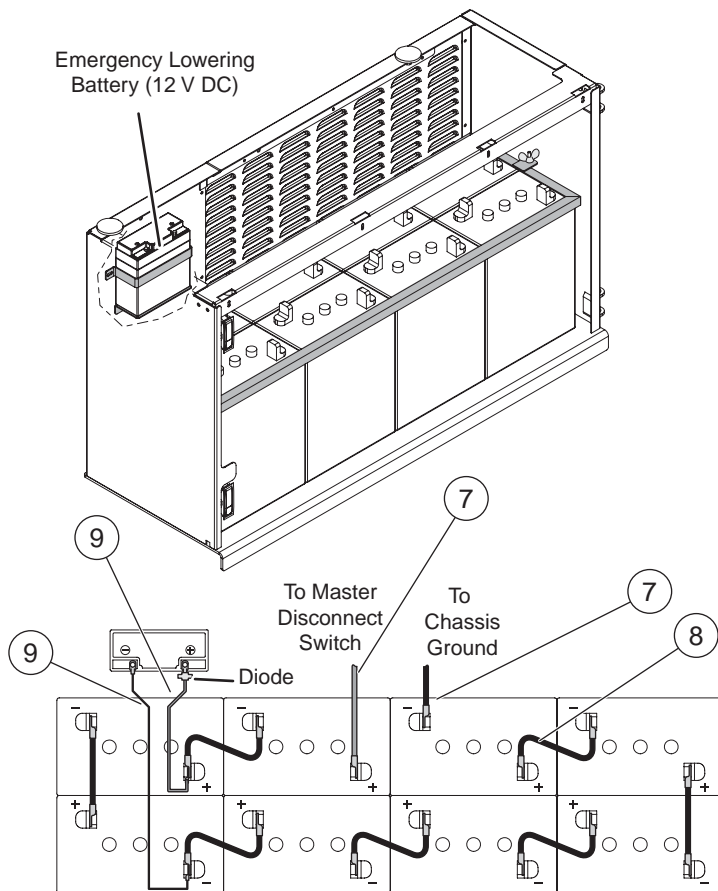

BATTERY PACK

CONTROL MODULE

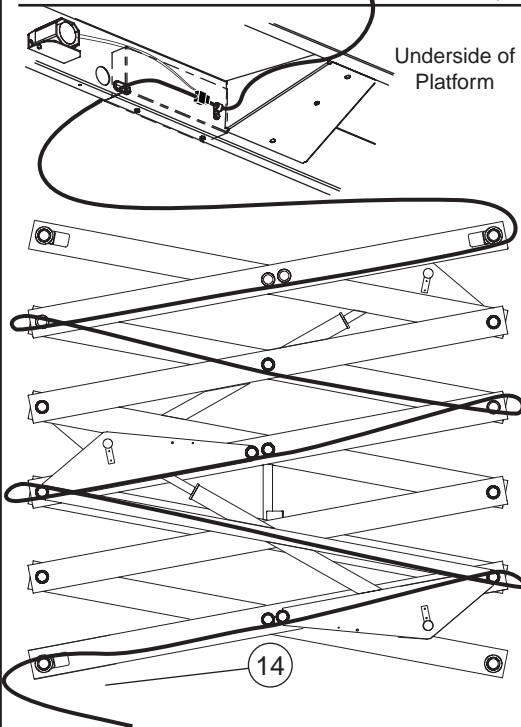
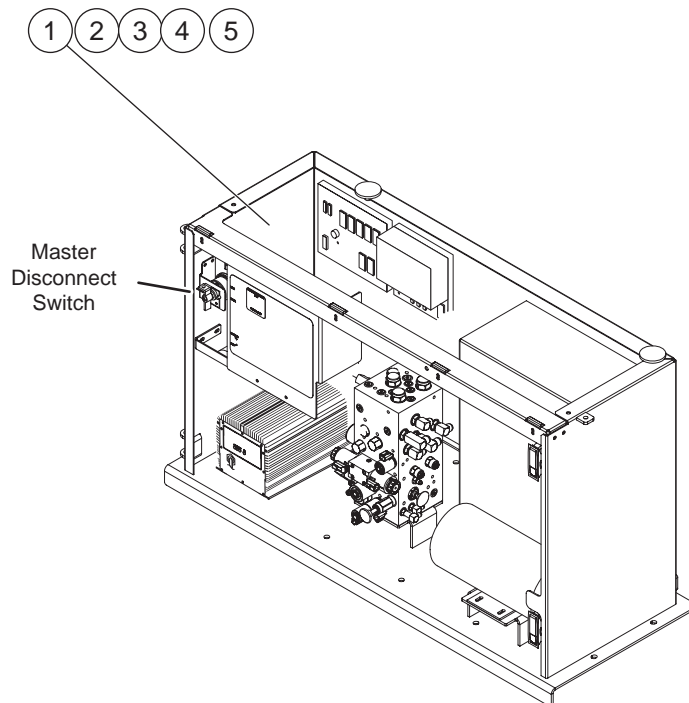

SCISSOR ASSEMBLY

Upper Controls

mecc
ILLUSTRATION No. 3072ES, 3772ES, 3772 ES HD
ART_2721

Wire Harness

ITEM	PART NO.	QTY	DESCRIPTION
1	91671	1	Harness, Main –Control Module - Base & Valves]
2	91069	1	Harness, Lift Cylinder Down Valve (3072ES) - Control Module to Lift Cylinder]
3	91085	1	Harness, Lower Lift Cylinder Down Valve (3772ES) - Control Module to Lift Cylinder]
4	91086	1	Harness, Upper Lift Cylinder Down Valve (3772ES) - Control Module to Lift Cylinder]
5	91672	1	Harness, Lower Controls - Inside Control Module]
6	91759	1	Cable, Battery to Master Disconnect
7	91760	1	Cable, Chassis Ground
8	6208	8	Cable, Battery, 8 Inch
9	91674	1	Harness, E-Down with Diode to Batteries (3772ES)
10	8346	1	Harness, Joystick
11	91758	1	Harness, Upper Controls, Removable - Up To Serial # 11211039
	91761	1	Harness, Upper Controls, Removable - Serial # 11211040 – Up
12	–	–	–
13	91780	1	Cable, Upper Controls, Removable
14	91757	1	Control Cable, 3072ES
	91756	1	Control Cable, 3772ES
–	91678	1	Harness, 2wd Disconnect, Limit Switch (not shown)
–	9411	1	Power to Platform (not shown)
–	91677	1	Harness, Outrigger (not shown)

• as req: as required

• INCL: Included with assembly

• NS: Not a Stock item

• REF: Reference only



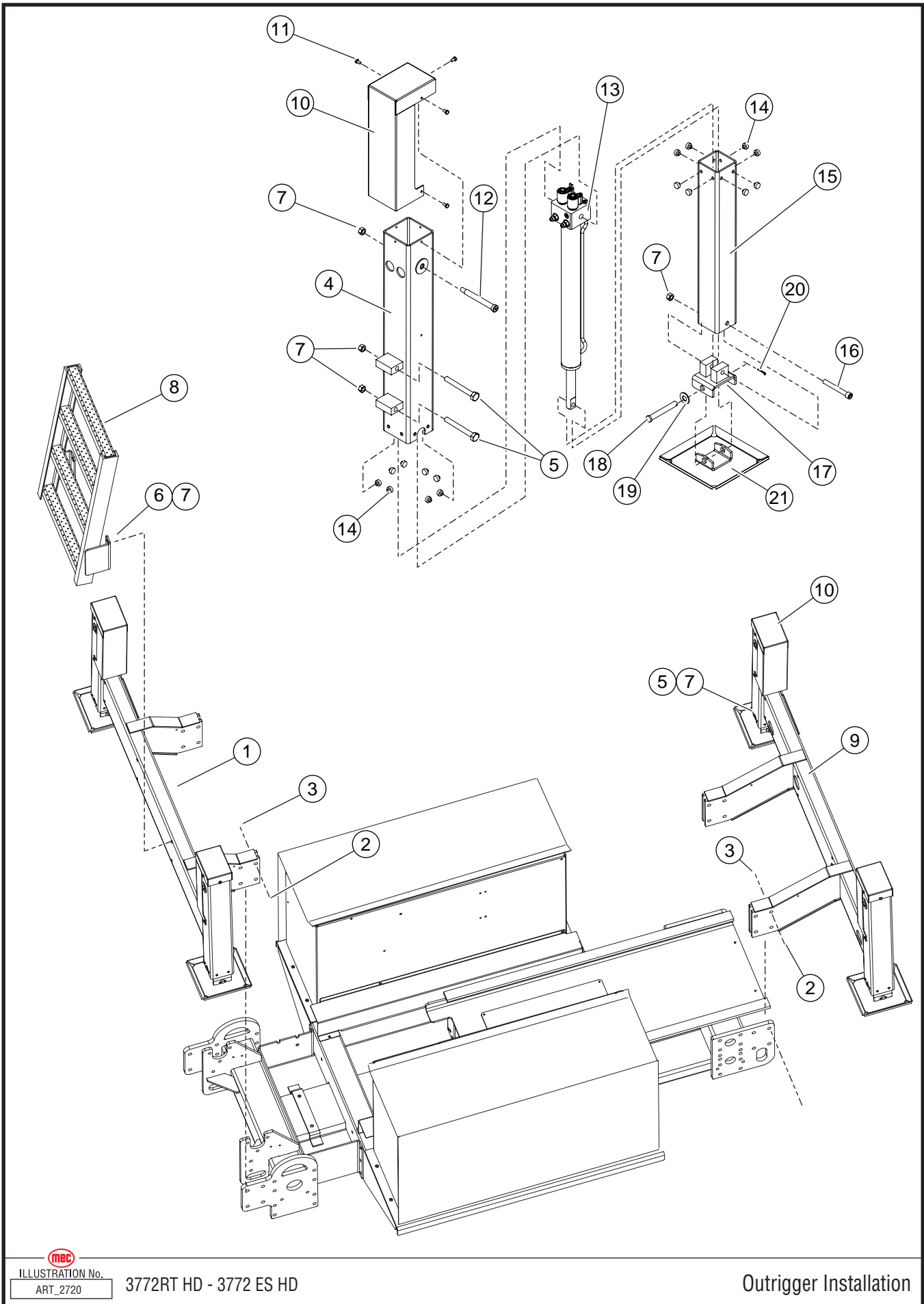

 ILLUSTRATION No. 3772RT HD - 3772 ES HD
 ART_2720

Outrigger Installation

Outrigger Installation (3772ES HD)

ITEM	PART NO.	QTY	DESCRIPTION
1	16279	1	Weldment, Outrigger Mount, Rear
2	HDW7938	16	Screw, 5/8-11 x 3" LG
3	HDW6633	16	Locknut, 5/8-11
4	21168	4	Weldment, Outer Outrigger
5	HDW7052	8	Screw, 1/2-13 x 3 1/2" LG
6	HDW8498	4	Screw, 1/2-13 x 4"
7	HDW8457	20	Nut, 1/2-13
8	16258	1	Ladder, 3072RT W/Outriggers
	16294	1	Ladder , 3772RT W/Outriggers
9	16278	1	Weldment, Outrigger Mount, Front
10	21170	4	Cover, Outrigger Cylinder
11	HDW6455	20	Screw, 1/4-20 x 1/2"
12	HDW91328	4	Shoulder Screw, 5/8 x 4.75"
13	91278	4	Cylinder, Outrigger
14	90663	64	Spacer
15	10335	4	Tube, Inner Outrigger
16	HDW5916	4	Screw, 1/2-13 x 4.0"
17	20998	4	Bracket Pivot
18	HDW91395	4	Clevis Pin, 5/8 x 5.0"
19	HDW9219	4	Washer, Flat
20	HDW5920	4	Pin, Cotter, 1/8 x 1"
21	21002	4	Pad Weldment

• as req: as required

• INCL: Included with assembly

• NS: Not a Stock item

• REF: Reference only



NOTES:



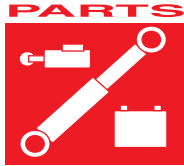

SECTION G

DECALS

CONTENTS	PAGE
Decals, ANSI Models	G-3
Decals, ANSI Models (continued)	G-5
Decals, CE Models	G-9
Decals, CE Models (continued)	G-11

1



MEC Aerial Platform Sales Corp.
1775 Park Street, Suite 77
Selma, California 93662
Phone: (559) 891-2488 Fax: (559) 891-2493

2

MEC 3072ES

5

3

MEC 3772ES

4

HD

6

Quad-Trax™ 4wd

7

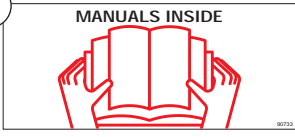

8

WARNING
INSPECT MACHINE AND MAKE SURE THAT IT IS OPERATING PROPERLY...
OTHER HAZARDS
FOR DRIVING ON ANY GRADE OR SIDE SLOPE:
FOR DRIVING WITH PLATFORM ELEVATED:

9

DANGER
YOU MUST NOT OPERATE
THIS MACHINE:
UNLESS YOU HAVE BEEN AUTHORIZED TO USE AND TRAINED IN THE SAFE OPERATION OF THIS MACHINE.
TIP-OVER HAZARDS
ELECTROCUTION HAZARD
THIS MACHINE IS NOT INSULATED.

10

WARNING
PLATFORM EXTENSION MUST BE LOCKED IN PLACE AT ALL TIMES.
SHEET LOADING GATE MUST BE IN LOWERED LOCKED POSITION BEFORE OPERATING FROM PLATFORM.
PLATFORM ENTRANCE MUST BE PROPERLY CLOSED AND ALL GUARDRAILS PROPERLY IN PLACE AND SECURED BEFORE OPERATING FROM PLATFORM.

11

Table with 4 columns: EXTENSION RETRACTED, EXTENSION EXTENDED, SIDE LOAD, and 1-PERSON. Includes diagrams of platform capacity.

12

Table with 4 columns: EXTENSION RETRACTED, EXTENSION EXTENDED, SIDE LOAD, and 1-PERSON. Includes diagrams of platform capacity.

13

PLATFORM CAPACITY
1000 Lbs (454kg)

14

PLATFORM CAPACITY
750 Lbs (340kg)

15

WARNING
LANYARD ANCHORAGE POINTS ARE RECOMMENDED FOR WORK POSITIONING RESTRAINTS ONLY.

17

WARNING
USE OR OPERATION OF AN UNSPECTED WORK PLATFORM COULD CAUSE DEATH, PERSONAL INJURY.
DO NOT OPERATE THIS WORK PLATFORM IF AN INSPECTION HAS NOT BEEN PERFORMED WITHIN 13 MONTHS OF THE LAST RECORDED INSPECTION DATE.

18



19

MAINTENANCE LOCK
REFER TO PARTS AND SERVICE MANUAL FOR PROPER USE

16

CERTIFIED LANYARD ANCHORAGE POINT

21

WARNING
EACH REPLACEMENT BATTERY MUST WEIGH A MINIMUM OF 60 POUNDS / 27.3 kg.

22



WARNING
BATTERIES PRODUCE EXPLOSIVE GAS. CHARGE BATTERIES IN WELL VENTILATED AREA. DO NOT EXPOSE TO SPARKS OR FLAMES.

23



24



25

KEEP CLEAR

NOTE: Decal placement is subject to the original country of the equipment destination.

MEC ILLUSTRATION No. ART_2746

3072ES - 3772ES - 3772ES HD

ANSI Models: Sheet 1 of 4

Decals

Decals, ANSI Models

ITEM	PART NO.	QTY	DESCRIPTION
1	90719	1	Decal, MEC Oval
2	91740	2	Decal, MEC 3072ES
3	91664	2	Decal, MEC 3772ES
4	91666	2	Decal, HD
5	8402	2	Decal, Rail Stripe
6	91266	2	Decal, Quad Trax 4wd
7	90733	1	Decal, Manuals Inside
8	91456	1	Decal, Warning Panel
9	90721	1	Decal, Danger, Electric - Tipover - Wind Rating
10	90730	1	Decal, Warning, Sheet Loading
11	91155	2	Decal, Capacity, 1000 LB (3072ES) (3772ES HD)
12	91322	2	Decal, Capacity, 750 LB (3772ES)
13	9932	1	Decal, Platform Capacity, Small (3072ES)
14	90269	1	Decal, Platform Capacity, Small (3772ES)
15	8606	1	Warning, Lanyard (option)
16	8605	5	Decal, Anchorage Point (option)
17	90718	1	Warning, Inspection Report
18	90739	1	Decal, Made in USA
19	90717	1	Decal, Maintenance Lock
20	11026730	1	Tie Down Point
21	90726	1	Warning, Battery Replacement
22	8779	1	Warning, Battery, Explosive Gas
23	9910	4	Decal, Pinch Point
24	7982	2	Decal, Safety Stripe (3072ES)
		4	Decal, Safety Stripe (3772ES)
25	8503	1	Decal, Keep Clear (3072ES)
		2	Decal, Keep Clear (3772ES)

... continued



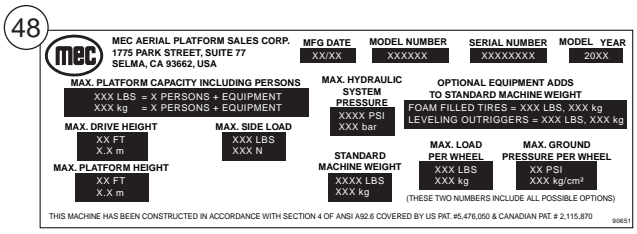
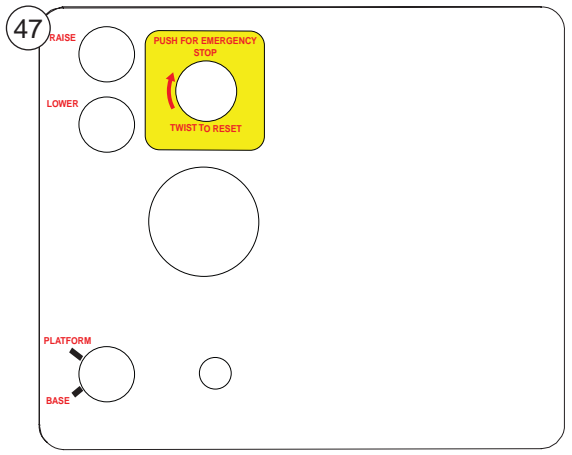
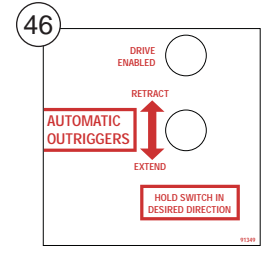
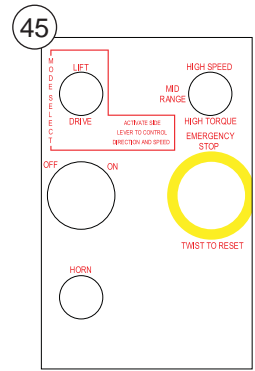
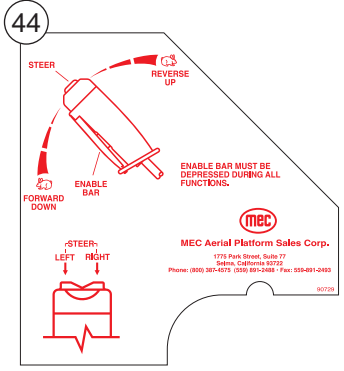
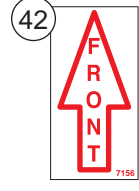
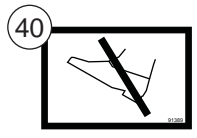
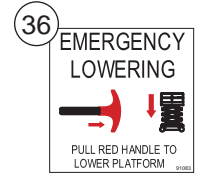
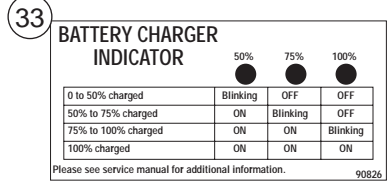
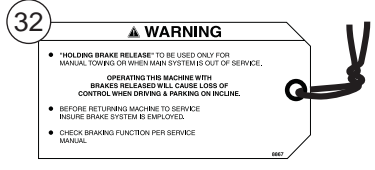
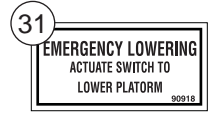
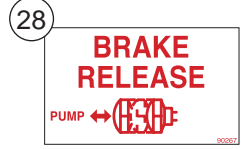
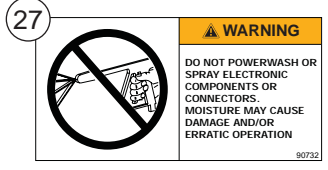
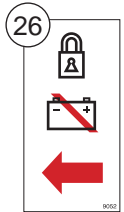

NOTE: Decal placement is subject to the original country of the equipment destination.

Decals, ANSI Models (continued)

ITEM	PART NO.	QTY	DESCRIPTION
26	9052	1	Decal, Battery Disconnect And Lock
27	90732	1	Decal, Warning, Pressure Wash
28	90267	1	Decal, Brake Release
29	6873	1	Decal, Hydraulic Oil
30	90918	1	Decal, Emergency Lowering Inside (3772ES)
31	91374	1	Decal, Emergency Lowering Switch (3772ES)
32	8867	1	Tag, Warning
33	90826	1	Decal, Battery Charge Indicator
34	8502	4	Decal, Tire Inflation
35	8519	4	Decal, Warning, Tire Replacement
36	91083	1	Decal, Emergency Lowering (3072ES)
37	90750	1	Decal, Battery Charger
38	90751	1	Decal, Power to Platform
39	9465	4	Decal, Danger, Keep Clear Outriggers
40	91389	1	Decal, No Step
41	6556	1	Decal, Fork lift Pockets
42	7156	1	Decal, Front
43	7155	1	Decal, Locate Control Box Here
44	90729	1	Decal, Upper Control Box, Side
45	91665	1	Decal, Upper Controls
46	91349	1	Decal, Outrigger Controls
47	91649	1	Decal, Lower Controls
48	90651	1	Serial Plate

• as req: as required

• INCL: Included with assembly

• NS: Not a Stock item

• REF: Reference only



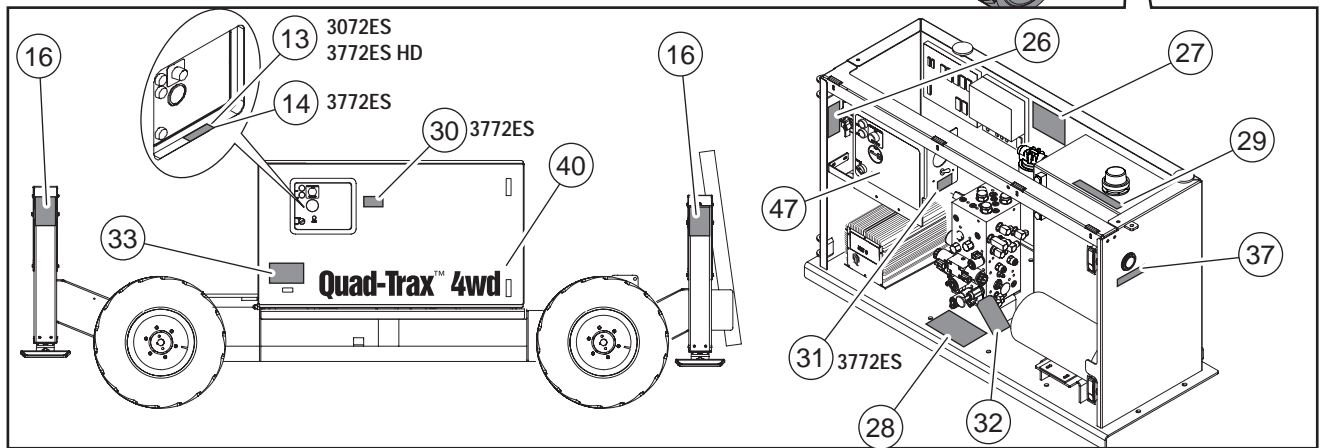
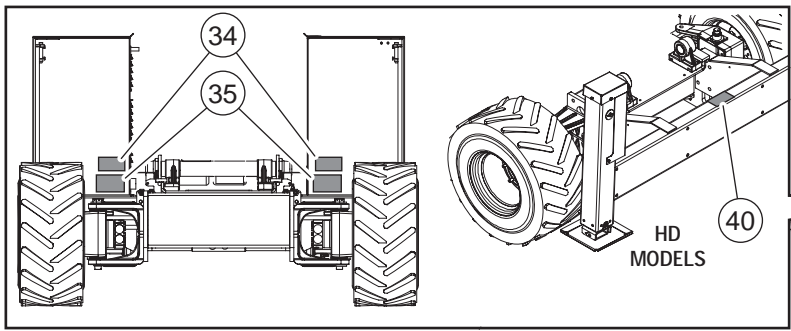
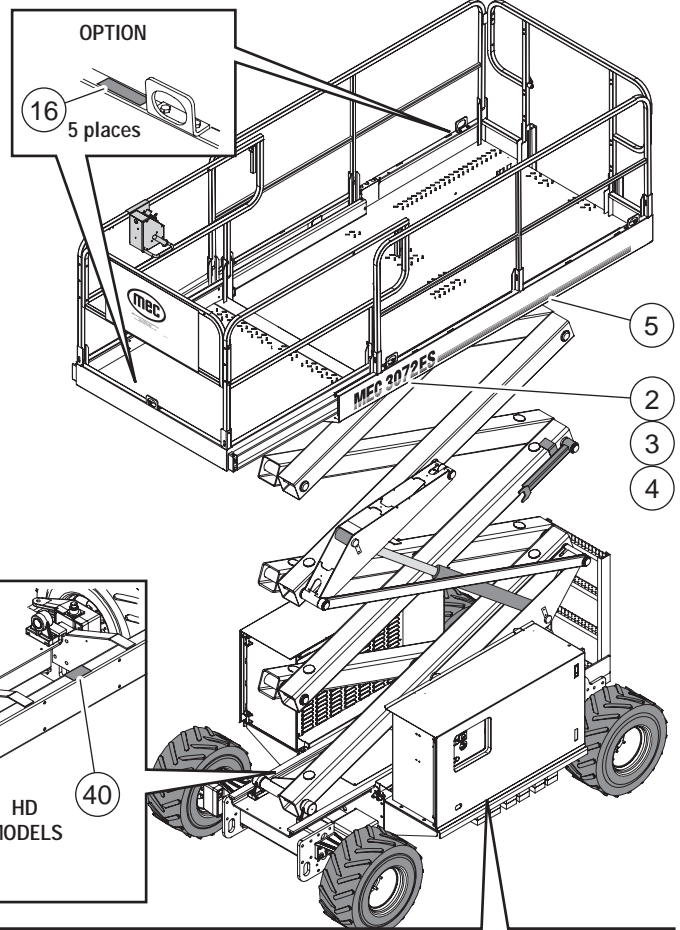
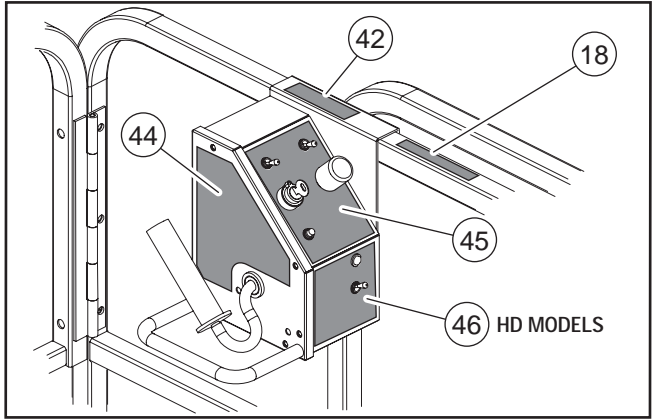
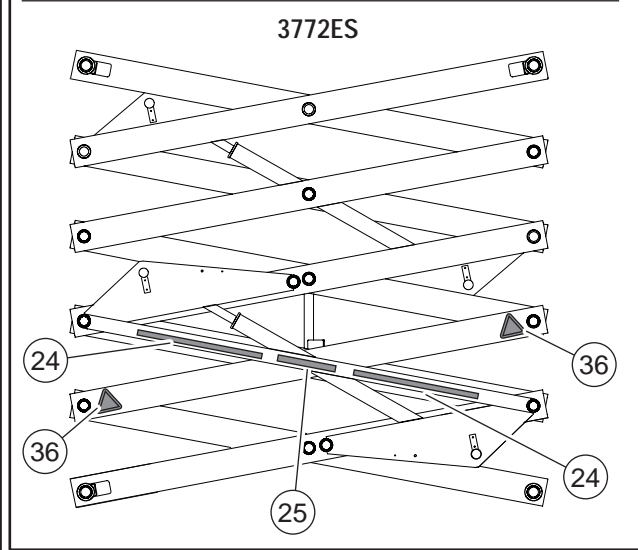
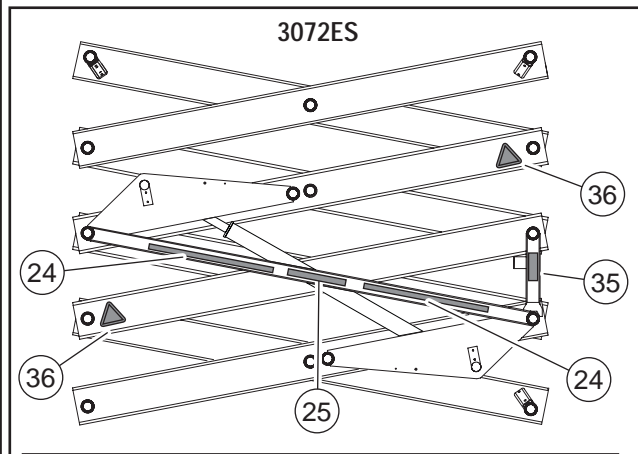

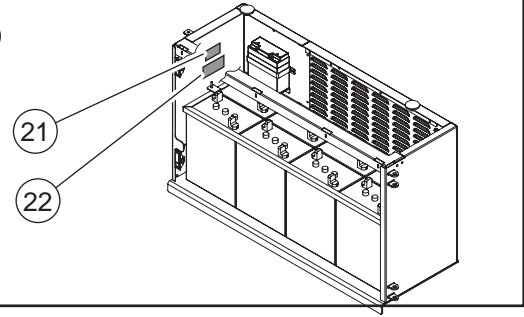
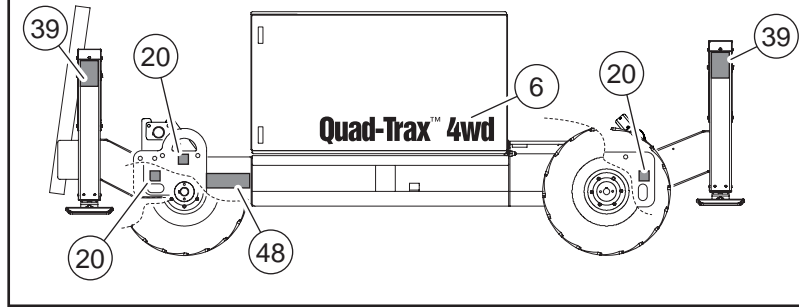
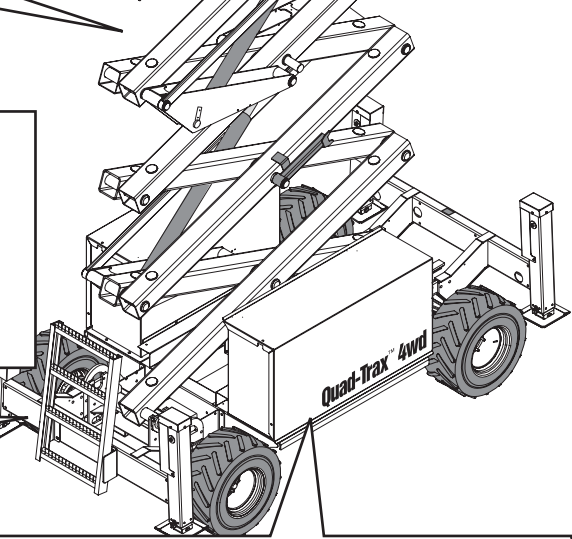
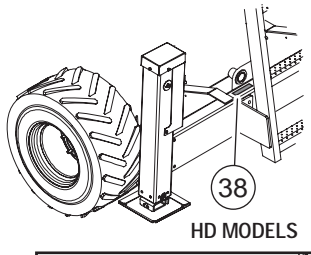
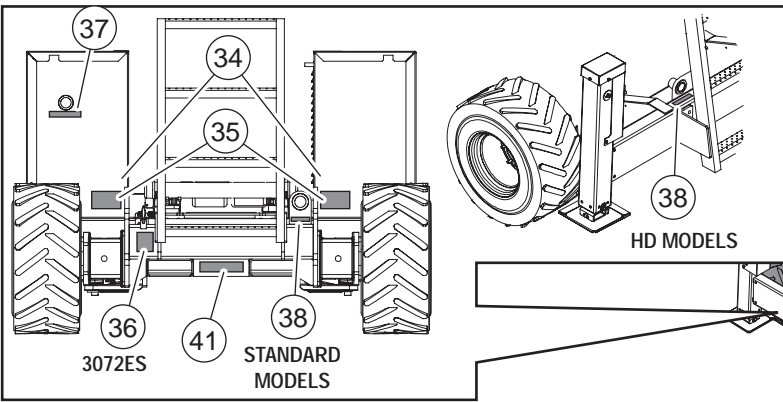
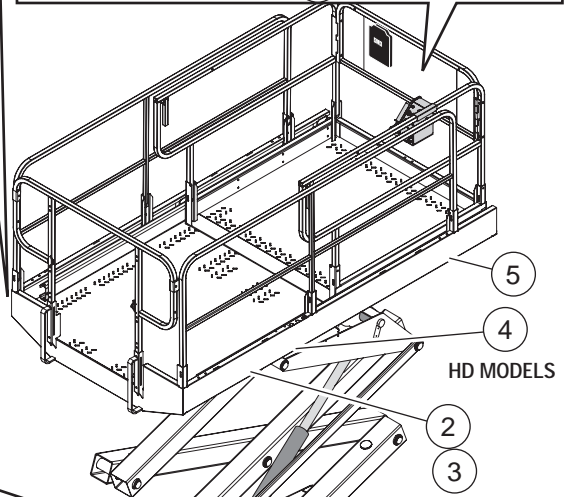
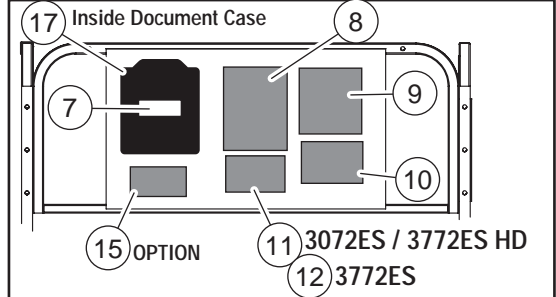
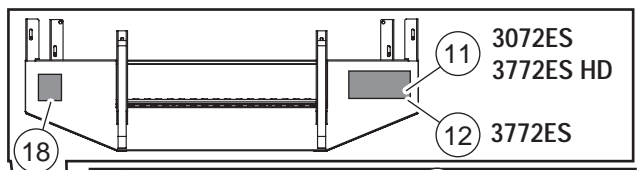
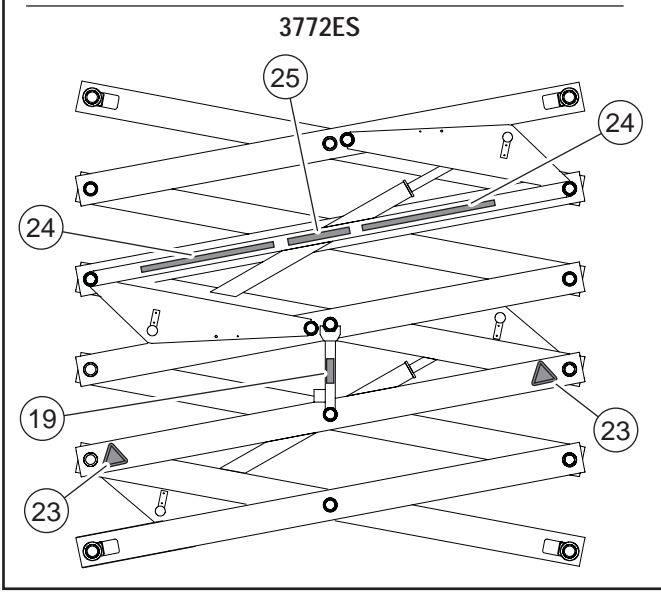
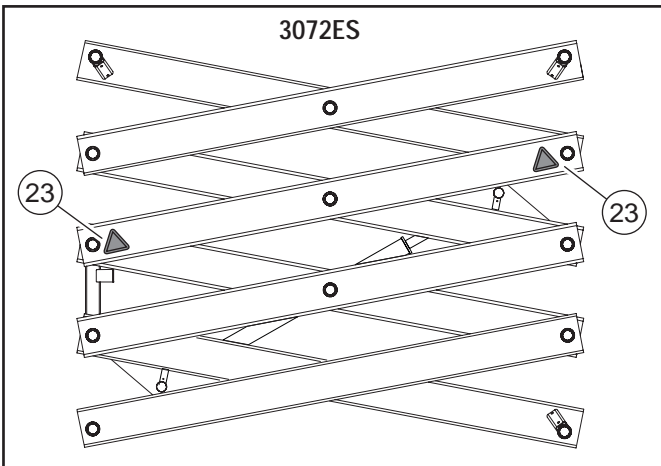

1



2

MEC 3072ES

5

3

MEC 3772ES

4

HD

6

Quad-Trax™ 4wd

7

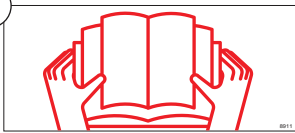

8

WARNING

INSPECT MACHINE AND MAKE SURE THAT IT IS OPERATING PROPERLY, THAT ALL NAME PLATE AND SAFETY AND CONTROL DECALS ARE IN PLACE AND LEGIBLE, AND THAT THE MACHINE IS IN ACCORDANCE WITH THE MANUFACTURER'S MAINTENANCE REQUIREMENTS CONTAINED IN THE OPERATION AND MAINTENANCE MANUAL, AND THE DAILY SAFETY CHECKLIST. OPERATE MACHINE WITH EXTREME CAUTION. WATCH FOR OBSTRUCTIONS WHICH MAY STRIKE PLATFORM, PERSONNEL, CONTROLS, OR MACHINE. OPERATE CONTROLS SLOWLY FOR SMOOTH PLATFORM MOTION.

OTHER HAZARDS

FOR DRIVING ON ANY GRADE OR SIDE SLOPE:

- PLATFORM MUST BE FULLY LOWERED.
- DO NOT EXCEED MAXIMUM PLATFORM OR EXTENSION LOAD LIMIT CAPACITY. LOADS TO BE UNIFORMLY DISTRIBUTED. PLACE LOAD NEAR CENTER OF PLATFORM WHEN POSSIBLE.
- DO NOT DRIVE ON SIDE SLOPE IF OVER 25% (54°).
- DO NOT DRIVE UP OR DOWN A GRADE THAT IS GREATER THAN THE GRADEABILITY SPECIFICATIONS FOR THIS MACHINE. SEE OPERATOR MANUAL FOR SPECIFICATIONS.

FOR DRIVING WITH PLATFORM ELEVATED:

- DRIVE ONLY ON A SMOOTH, FIRM, AND LEVEL SURFACE FREE OF OBSTRUCTIONS.
- DO NOT EXCEED MAXIMUM PLATFORM OR EXTENSION LOAD CAPACITY.
- LOAD MUST BE UNIFORMLY DISTRIBUTED.
- USE EXTREME CAUTION.

IMPROPER OPERATION OF THIS MACHINE COULD CAUSE DEATH OR SERIOUS INJURY.

9

DANGER

YOU MUST NOT OPERATE THIS MACHINE:
UNLESS YOU HAVE BEEN AUTHORIZED TO USE AND TRAINED IN THE SAFE OPERATION OF THIS MACHINE. TRAINING INCLUDES COMPLETE KNOWLEDGE OF THE SAFETY AND OPERATION INSTRUCTIONS CONTAINED IN THE MANUFACTURER'S MANUAL, EMPLOYEE SAFETY TRAINING, YOUR EMPLOYER'S WORK RULES AND APPLICABLE GOVERNMENTAL REGULATIONS. AN UNAUTHORIZED AND UNTRAINED OPERATOR SUBJECTS HIMSELF AND OTHERS TO DEATH OR SERIOUS INJURY.

ELECTROCUTION HAZARD
THIS MACHINE IS NOT INSULATED.

MANTAIN SAFE CLEARANCE FROM ELECTRICAL LINES AND ARMATURES: THE BEST ALLOW FOR MACHINE SWAY, ROCK OR SAG AND ELECTRICAL LINES SWINGING.

THIS MACHINE DOES NOT PROVIDE PROTECTION FROM CONTACT WITH OR PROXIMITY TO AN ELECTRICALLY CHARGED CONDUCTOR.

YOU MUST MAINTAIN A CLEARANCE OF AT LEAST TEN (10) FEET BETWEEN ANY PART OF THIS MACHINE OR ITS LOAD AND ANY ELECTRICAL LINE. ONE FOOT OF ADDITIONAL CLEARANCE IS REQUIRED FOR EVERY ADDITIONAL 30,000 VOLTS OR LESS OF PLATFORM.

DEATH OR SERIOUS INJURY WILL RESULT FROM CONTACT OR INADEQUATE CLEARANCE.

TIP-OVER HAZARDS

- DO NOT DRIVE NEAR DROP-OFFS, HOLES, OPEN ELEVATOR SHAFTS, AND LOADING DOCKS.
- DO NOT ELEVATE PLATFORM ON UNEVEN OR SOFT SURFACES. DO NOT DRIVE ONTO UNEVEN OR SOFT SURFACES WHEN ELEVATED.
- DO NOT RAISE PLATFORM ON SLOPE, OR DRIVE ONTO SLOPE WHEN ELEVATED.
- DO NOT RAISE PLATFORM IN WINDY OR GUSTY CONDITIONS.

DEATH OR SERIOUS INJURY WILL RESULT FROM IMPROPER USE OF THIS EQUIPMENT.

10

WARNING

- PLATFORM EXTENSION MUST BE LOCKED IN PLACE AT ALL TIMES.
- SHEET LOADING GATE MUST BE IN LOWERED LOCKED POSITION BEFORE OPERATING FROM PLATFORM.
- PLATFORM ENTRANCE MUST BE PROPERLY CLOSED AND ALL GUARDRAILS PROPERLY IN PLACE AND SECURED BEFORE OPERATING FROM PLATFORM.

FAILURE TO FOLLOW INSTRUCTIONS COULD CAUSE DEATH, PERSONAL INJURY AND PROPERTY DAMAGE.

11

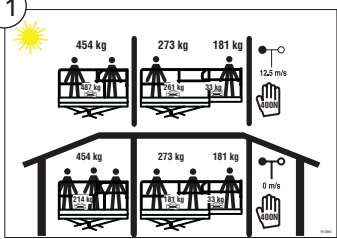

12

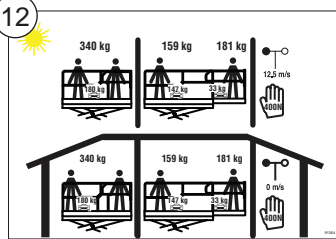

25

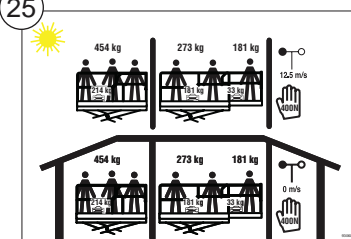

13

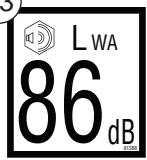

15

WARNING

- LANYARD ANCHORAGE POINTS ARE RECOMMENDED FOR WORK POSITIONING RESTRAINTS ONLY. USE OF FALL ARREST SYSTEMS ATTACHED TO ANCHORAGE POINTS ON MOBILE EQUIPMENT MAY CAUSE MACHINE TO TIP, RESULTING IN SERIOUS INJURY OR DEATH.

17

WARNING

USE OR OPERATION OF AN UNSPECTED WORK PLATFORM COULD CAUSE DEATH, PERSONAL INJURY.

NEW	<ul style="list-style-type: none"> DO NOT OPERATE THIS WORK PLATFORM IF AN INSPECTION HAS NOT BEEN PERFORMED WITHIN 13 MONTHS OF THE LAST RECORDED INSPECTION DATE. STAMP MONTH/DAY/YEAR NEXT TO APPROPRIATE YEAR AFTER EACH INSPECTION. 	6TH YEAR
1ST YEAR		7TH YEAR
2ND YEAR		8TH YEAR
3RD YEAR		9TH YEAR
4TH YEAR		10TH YEAR

NOTICE - CHANGE OF OWNERSHIP OF THIS WORK PLATFORM MUST BE REPORTED TO MANUFACTURER:
MEC Aerial Platform Sales Corp.
1775 E. Garden Avenue
Fresno, California 93725 Phone: (559) 263-9626

18



19

MAINTENANCE LOCK

ENSURE LOCK IS IN PLACE BEFORE DOING MAINTENANCE ON ELEVATED WORK PLATFORM

20



21

WARNING

- EACH REPLACEMENT BATTERY MUST WEIGH A MINIMUM OF 60 POUNDS / 27.3 kg
- FAILURE TO MEET MINIMUM WEIGHT REQUIREMENT MAY CAUSE MACHINE INSTABILITY.

22

WARNING

BATTERIES PRODUCE EXPLOSIVE GAS. CHARGE BATTERIES IN WELL VENTILATED AREA. DO NOT EXPOSE TO SPARKS OR FLAMES.

23



24



NOTE: Decal placement is subject to the original country of the equipment destination.

MEC
ILLUSTRATION No.
ART_2750

3072ES - 3772ES - 3772ES HD

CE Models: Sheet 1 of 4

Decals

Decals, CE Models

ITEM	PART NO.	QTY	DESCRIPTION
1	90719	1	Decal, MEC Oval
2	91740	2	Decal, Mec 3072ES
3	91664	2	Decal, Mec 3772ES
4	91666	2	Decal, HD
5	8402	2	Decal, Rail Stripe
6	91266	2	Decal, Quad Trax 4wd
7	8911	1	Decal, Manuals Inside
8	91456	1	Decal, Warning Panel
9	90721	1	Decal, Danger, Electric - Tipover - Wind Rating
10	90730	1	Decal, Warning, Sheet Loading
11	91385	2	Decal, Capacity, 1000 LB (3072ES)
12	91384	2	Decal, Capacity, 750 LB (3772ES)
13	91388	1	Noise Level
14	-	-	-
15	8606	1	Warning, Lanyard (option)
16	8605	5	Decal, Anchorage Point (option)
17	90718	1	Warning, Inspection Report
18	90739	1	Decal, Made in USA
19	90717EUR	1	Decal, Maintenance Lock
20	11026730	1	Tie Down Point
21	90726	1	Warning, Battery Replacement
22	8779	1	Warning, Battery, Explosive Gas
23	9910	4	Decal, pinch point
24	7982	2	Decal, Safety Stripe (3072ES)
		4	Decal, Safety Stripe (3772ES)
25	93060	2	Decal, Capacity, 1000 LB (3772ES HD)

... continued

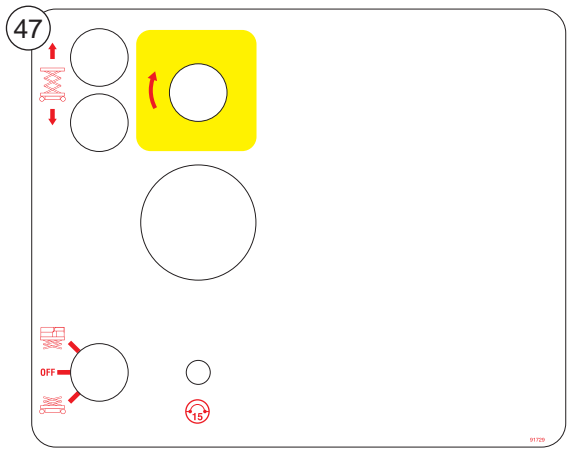
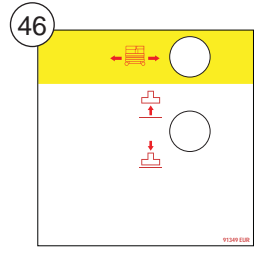
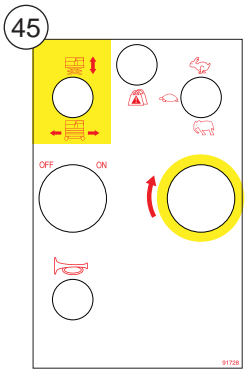
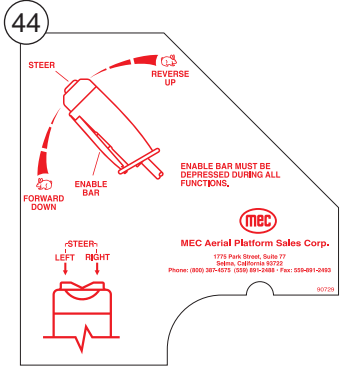
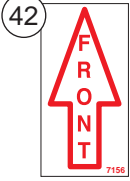
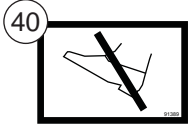
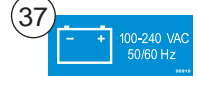
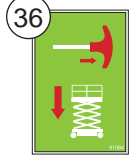
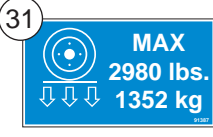
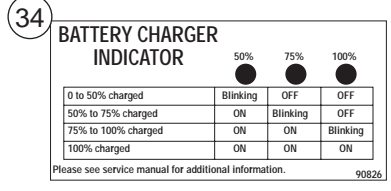
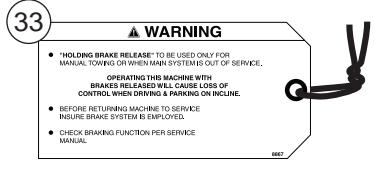
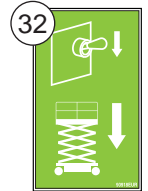
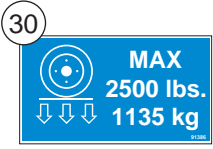
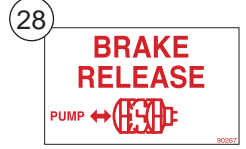
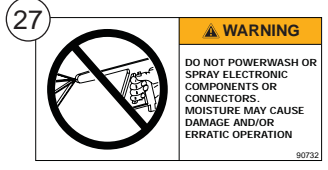
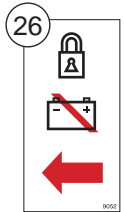

48

MEC AERIAL PLATFORM SALES CORP. 1775 PARK STREET, SUITE 77 SELMA, CA, USA		MFG. DATE XX/XX	MODEL NUMBER XXXXXX	SERIAL NUMBER XXXXXXXXXX	MODEL YEAR 20XX
MAX. PLATFORM CAPACITY INCLUDING PERSONS XXX kg = X PERSONS + XXX kg EQUIPMENT		MAX. ALLOWABLE MANUAL FORCE XXX N		MAX. PLATFORM HEIGHT X.X m	
0 m/s		XXX kg = X PERSONS + XXX kg EQUIPMENT		X.X m	
12.5 m/s		XXX kg = X PERSONS + XXX kg EQUIPMENT		XXX kg	
MAX. ALLOWABLE INCLINATION X.X° x X.X°	ELECTRICAL VOLTAGE 100-220 VAC 50/60 Hz	MAX. GROUND PRESSURE PER WHEEL X.X kg/cm²	MAX. LOAD PER WHEEL XXX kg	MACHINE WEIGHT XXXX kg	

NOTE: Decal placement is subject to the original country of the equipment destination.

MEC
ILLUSTRATION No.
ART_2751

3072ES - 3772ES - 3772ES HD

CE Models: Sheet 2 of 4

Decals

Decals, CE Models (continued)

ITEM	PART NO.	QTY	DESCRIPTION
26	9052	1	Decal, Battery Disconnect And Lock
27	90732	1	Decal, Warning, Pressure Wash
28	90267	1	Decal, Brake Release
29	6873	1	Decal, Hydraulic Oil
30	91386	4	Decal, Wheel Load (3072ES)
31	91387	4	Decal, Wheel Load (3772ES)
32	90918EUR	2	Decal, Emergency Lowering Switch (3772ES)
33	8867	1	Tag, Warning
34	90826	1	Decal, Battery Charge Indicator
35	8519	4	Decal, Warning, Tire Replacement
36	91084	1	decal, emergency lowering (3072es)
37	90919	1	Decal, Battery Charger
38	90751	1	Decal, Power to Platform
39	9465	4	Decal, Danger, Keep Clear Outriggers
40	91389	1	Decal, No Step
41	90930	2	Decal, Fork lift Pockets
42	7156	1	Decal, Front
43	7155	1	Decal, Locate Control Box Here
44	90729	1	Decal, Upper Control Box, Side
45	91728	1	Decal, Upper Controls
46	91730	1	Decal, Outrigger Controls
47	91729	1	Decal, Lower Controls
48	90586	1	Serial Plate

• as req: as required

• INCL: Included with assembly

• NS: Not a Stock item

• REF: Reference only



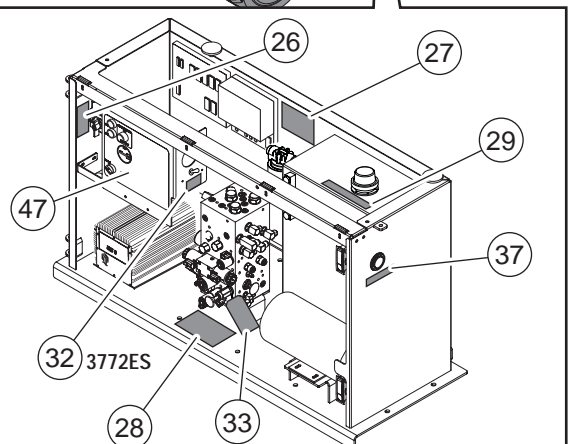
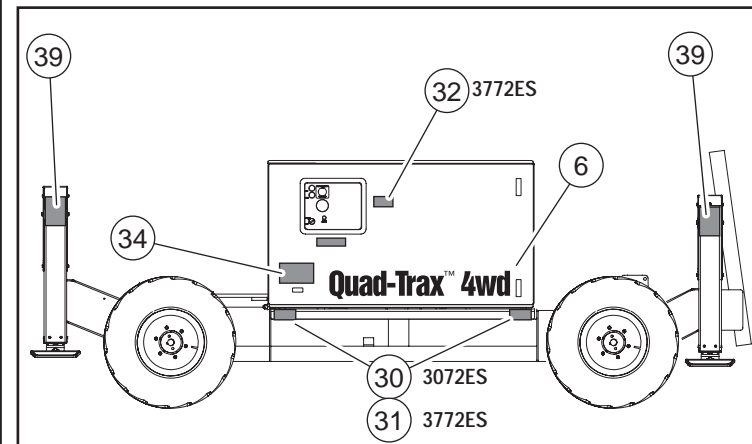
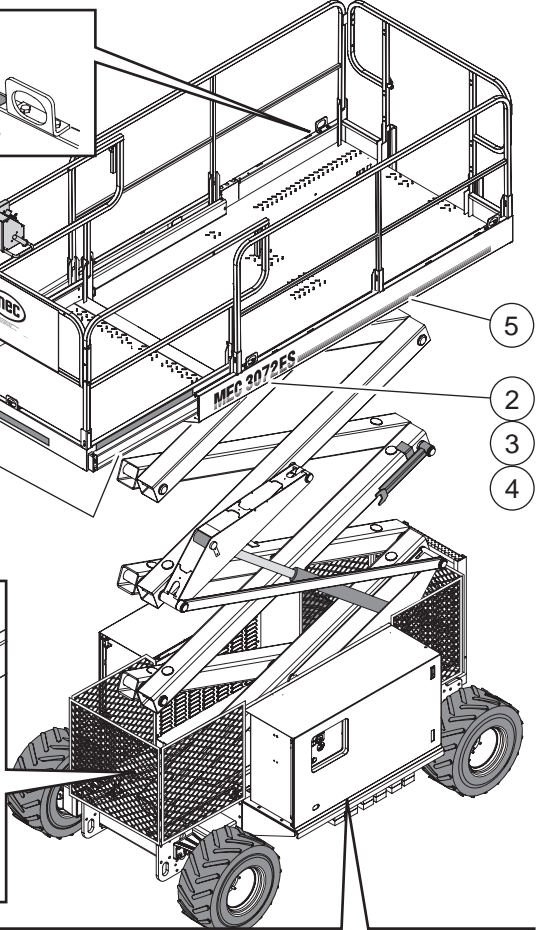
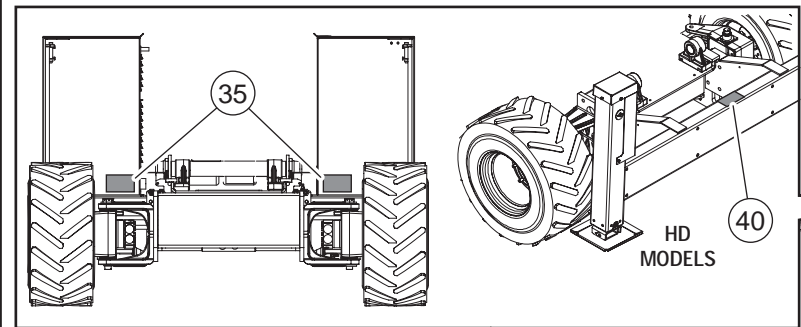
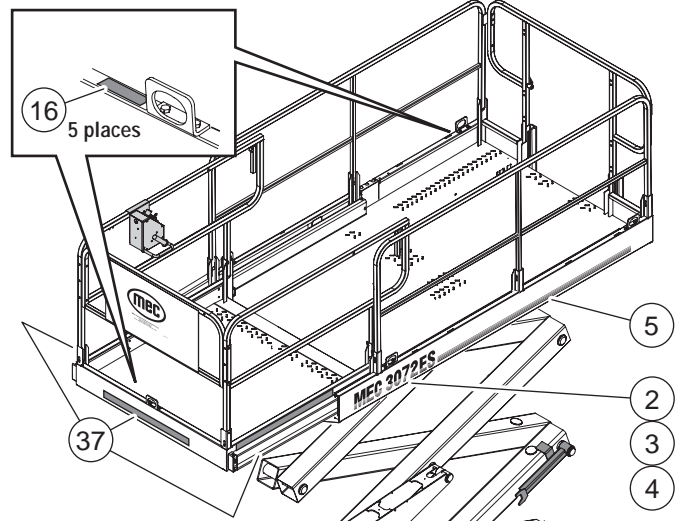
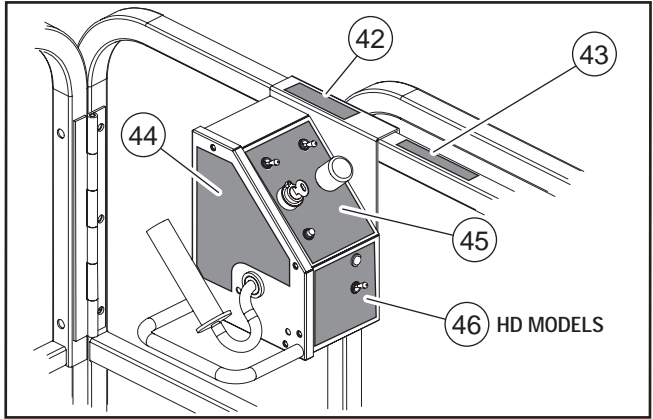
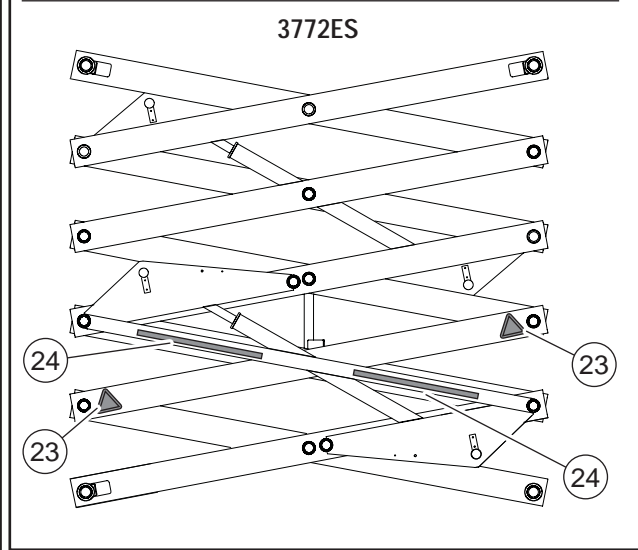
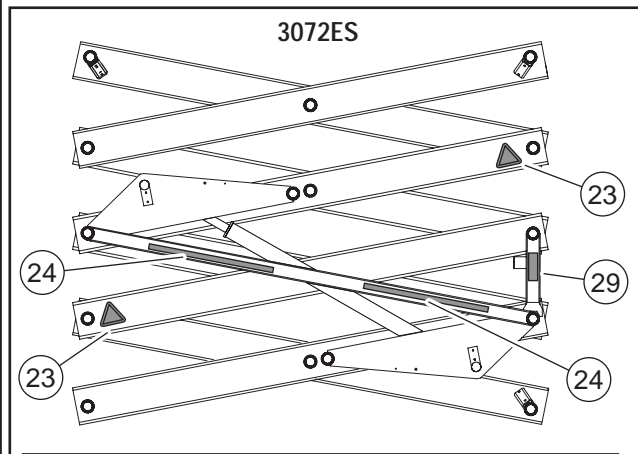

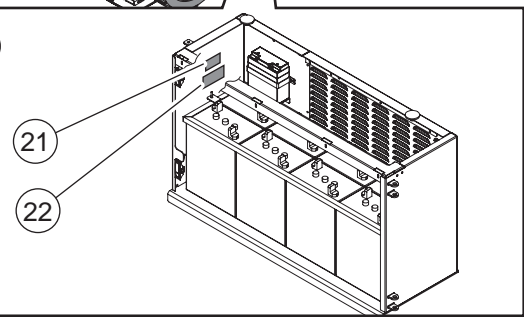
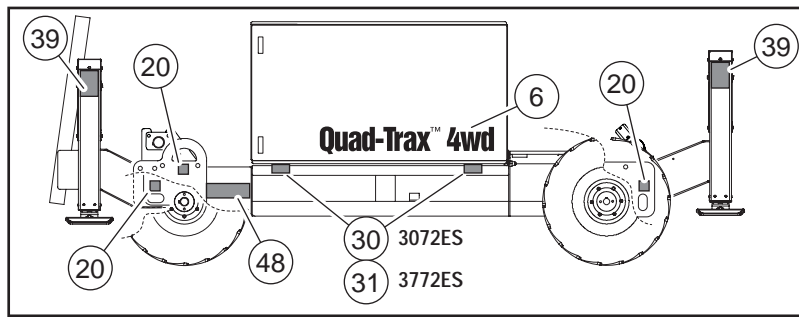
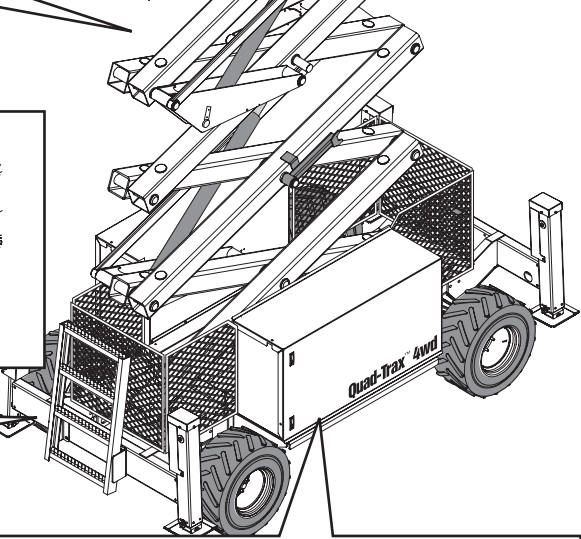
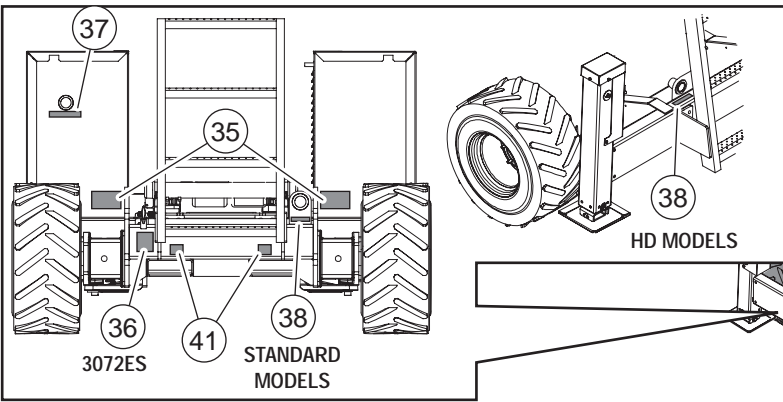
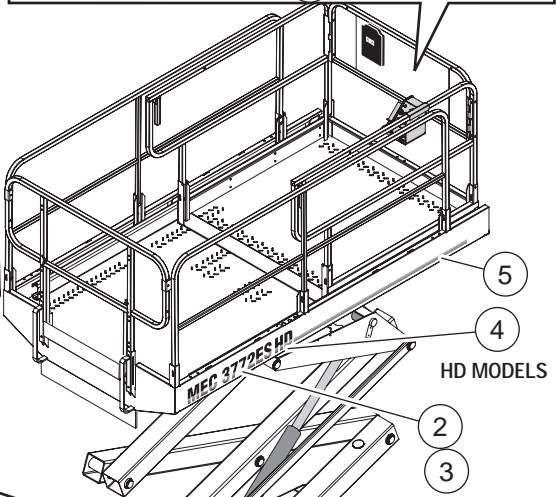
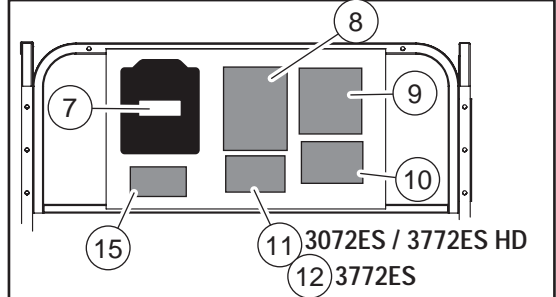
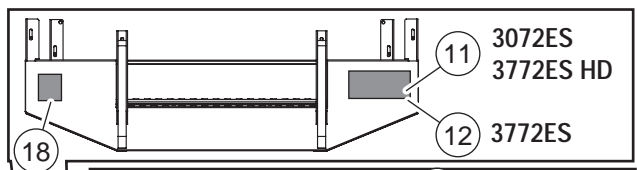
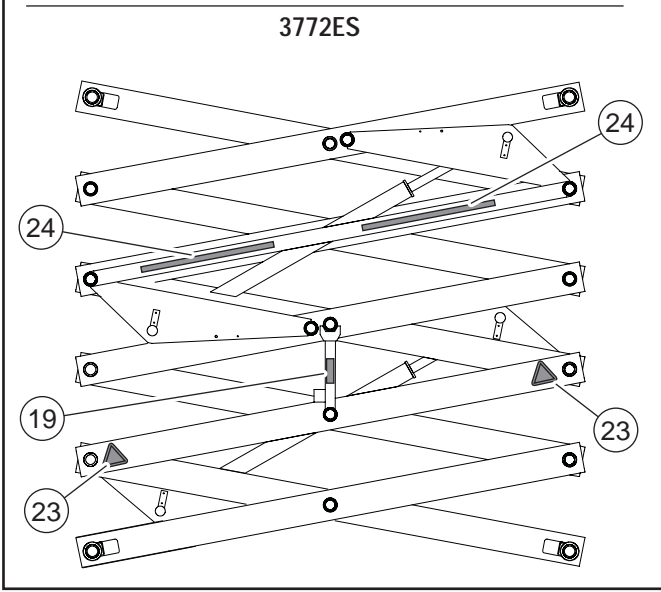
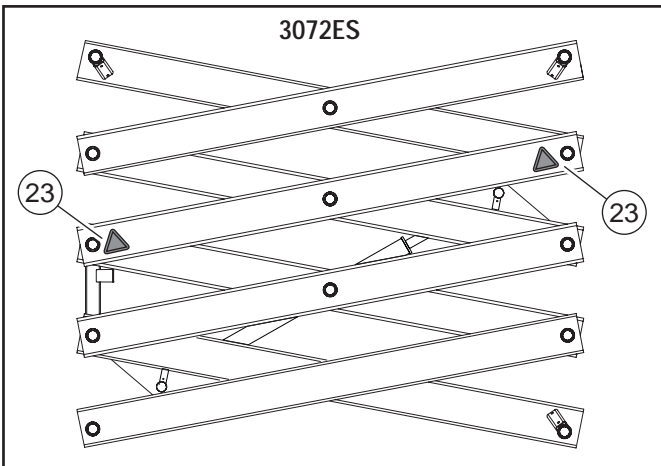

NOTES:



Part Number Index

Part Number	Page	Part Number	Page
1008348	A-7	16284	C-5
10335	F-17	16285	C-5
10709	D-5	16286	C-5
10907	E-27	16287	C-5
11026730	G-3, G-9	16288	C-5, C-11
13175	C-7, C-9	16289	C-5
13230	B-7	16290	C-5
13272	B-11	16292	C-5, C-11
13402	A-7	16293	F-3
13403	A-7	16294	F-17
13502	A-7	16313	F-7
13527	A-7	16320	C-17
13638	A-9	16323	C-17
13647	A-7	16324	C-17
13737	B-5	16325	C-17
13838	C-15	16332	C-17
13846	B-9	16348	D-3
13864	A-3, A-5	16349	D-3
13865	A-3, A-5	16350	C-19
13868	A-7	16353	C-19
14062	B-7	16355	C-19
14152	B-3	16359	C-19
14301	B-3	16368	F-5
14313	B-3	16619	F-13
14331	D-5	16620	F-13
14344	B-5	16736	F-5
14415	B-3	16974	F-13
14487	C-3, C-5, C-9, C-13	16983	F-13
14488	C-3, C-5, C-9, C-13	16984	F-7
14537	C-3, C-5, C-9, C-13	16985	F-7
14538	C-3, C-5, C-9, C-13	16995	F-11
14583	B-17	17009	C-11
14604	B-13	17011	C-11
14773	D-3	17012	C-9, C-13
14806	C-3, C-5, C-9	17014	C-11
14896	F-9, F-13	17015	C-11
14990	C-3, C-7	17017	C-11
14993	F-3	17018	C-11
16062	E-19, E-21, E-23	17019	C-11
16120	A-3	17065	C-7
16153	F-7	17067	C-7
16154	F-9	17070	C-7
16160	F-3	17071	C-7
16164	F-7	17082	A-11
16165	F-7	20311	D-5
16176	B-3	20312	D-5
16177	B-3	20552	B-3
16196	B-3	20998	F-17
16202	B-3	21002	F-17
16206	F-3	21168	F-17
16221	B-15	21170	F-17
16222	B-3	23689	E-15
16224	B-3	25429	C-3, C-5, C-7, C-9, C-11, C-13, F-9, F-13
16226	F-9	2987	F-13
16229	F-9	30407	C-5
16242	A-3, A-5	30518	C-5, C-11
16258	F-17	30814	B-11
16278	F-17	3763	A-7
16279	F-17	3764	A-7
16282	C-5, C-13	3765	A-7
16283	C-3, C-5	3766	A-7



Part Number Index

Part Number	Page
3772	A-7
3782	A-7
3923	B-17
40003	B-11
40006	B-11
40014	B-11
40015	B-11
40017	B-11
40081	C-3, C-7
40083	C-3, C-7
40084	C-3
40106	C-5, C-11
40124	C-5
40159	F-3, F-5
40258	D-3
40306	C-3, C-5, C-9, C-13
40308	D-5
40334	D-5
40444	C-3
40446	C-3
40447	C-3, C-7
40448	C-3, C-7
40459	C-3, C-5, C-9, C-13
40464	D-5
40524	C-15
40590	F-5
40620	F-13
40826	F-13
5239	B-9
5351	B-15
5381	B-15
5432	C-3, C-5, C-9, C-13
5694	A-3, A-5
5736	A-7
5863	B-13
5882	B-15
5904	F-11
5918	B-7
6110	F-13
6156	F-9
6208	F-15
6234	A-3, A-5
6350	A-3
6458	E-13, E-15, E-19, E-21, E-23
6556	G-5
6633	D-3
6669	C-3, C-5, C-9, C-13, E-19
6701	C-3, C-5, C-7, C-9, C-11, C-13
6714	F-9
6727	F-9
6823	B-3, B-11
6873	G-5, G-11
6905	A-3, A-5
6917	A-7
6947	B-13
6964	B-13
7048	B-3
7055	B-11
7155	G-5, G-11
7156	G-5, G-11
7160	C-3, C-5, C-9, C-13

Part Number	Page
7184	B-5
7235	A-11
7292	D-5
7293	E-25
7300P	D-5, D-9
7391	E-15
7408	B-5
7423	A-11
7476	A-9
7484	E-3
7553	A-5
7598	E-17
7617	B-15
7777	A-9
7788	E-19, E-21, E-23
7800	A-3, A-5
7805	B-3
7818	A-7
7819	A-7
7875	A-7
7882	A-7
7909	A-11
7982	G-3, G-9
8044	A-3, A-5
8082	A-3, A-5
8083	A-3, A-5
8089	A-9
8187	B-11
8208	B-15
8209	B-15
8267	F-9
8273	F-11
8300	B-11
83050	F-9
83051	A-3
83059	A-3
8318	E-17
8346	F-15
8368	F-11
8383	A-7
8386	F-7
8389	A-7
8402	G-3, G-9
84077	F-7
8435	A-7
8447	A-9
8448	A-9
8453	A-9
8456	A-9
8479	B-15
8502	G-5
8503	G-3
8519	G-5, G-11
8559	B-15
8605	B-17, G-3, G-9
8606	B-17, G-3, G-9
8630	A-9
8675	C-3, C-5, C-7, C-11
8696	A-7
8748	A-9
8750	A-9



Part Number Index

Part Number	Page	Part Number	Page
8751	A-9	90996	C-15
8752	A-9	91012	E-3
8753	A-9	91015	E-3
8761	A-9	91019	D-5, E-25
8779	G-3, G-9	91020	C-3, C-9, E-19
8781	B-9	91047	E-17
8785	C-3, C-9, C-13	91051	E-19
8814	B-5	91069	F-15
8826	A-3, A-5	91083	G-5
8833	B-15	91084	G-11
8841	F-9	91085	F-15
8867	G-5, G-11	91086	F-15
8909	B-3	91138	D-7
8911	G-9	91140	E-3, F-9
8925	D-3	91141	D-3, E-3, E-19, E-21, E-23, E-27
90235	C-3, C-5, C-9, C-13	91142	E-3, E-9
90267	G-5, G-11	91144	E-3
90269	G-3	91145	E-3
90275	E-13	91146	E-3
90282	D-5	91147	E-3
9029	E-15	91149	E-3
90315	E-15	91150	E-3
9038	E-17	91151	E-3
9039	E-15, E-21	91152	E-3
90439	E-27	91153	E-3
9052	G-5, G-11	91154	E-3
90586	G-11	91155	G-3
90592	D-9	91159	A-3, A-5
90651	G-5	91165	D-3, D-5
90663	F-17	91166	D-3, D-5
90717	G-3	91167	D-3, D-5
90717EUR	G-9	91168	D-3, D-5
90718	G-3, G-9	91180	D-3
90719	G-3, G-9	91181	D-3
90721	G-3, G-9	91182	E-19
90726	G-3, G-9	91192	E-11
90729	G-5, G-11	91193	E-11
90730	G-3, G-9	91194	A-3
90732	G-5, G-11	91247	E-15
90733	G-3	91249	E-13
90739	G-3, G-9	91254	E-13
90749	F-9	91255	E-13
90750	G-5	91256	E-13
90751	G-5, G-11	91257	E-11
90765	D-3, D-5	91258	E-11
90789	A-3, A-5	91259	E-11
90826	G-5, G-11	91260	E-11
90827	B-15	91261	E-11
90828	B-15	91263	D-5, E-11
90873	A-5	91265	E-15
90898	F-13	91266	G-3, G-9
90918	G-5	91277	E-27
90918EUR	G-11	91278	E-27, F-17
90919	G-11	91281	E-27
90930	G-11	91284	B-3
90969	E-21, E-23	91314	C-5, C-13, E-21
90985	E-15, E-19	91315	C-5, C-13, E-23
90987	E-23	91319	D-3, D-7
90988	E-21	91322	G-3
90990	D-5, E-25	91346	E-17
90993	E-21, E-23	91347	E-17



Part Number Index

Part Number	Page
91349	G-5
91350	E-3
91351	E-3
91352	E-3
91353	E-3
91354	E-3
91355	E-3
91356	E-3
91374	G-5
91377	E-23
91384	G-9
91385	G-9
91386	G-11
91387	G-11
91388	G-9
91389	G-5, G-11
91399	B-15
91456	G-3, G-9
91460	E-19
91462	E-21, E-23
91463	E-27
91464	D-3, E-27
91466	E-15
91468	E-15
91533	A-11
91534	A-11
91537	A-11
91538	A-11
91585	D-3
91637	F-11
91640	F-9
91641	F-13
91649	G-5
91655	F-11
91657	E-7, F-11
91658	F-9
91659	F-9
91663	A-3, A-5
91664	G-3, G-9
91665	G-5
91666	G-3, G-9
91671	F-15
91672	F-15
91674	F-15
91677	F-15

H

HDW13175	C-3, C-5, C-11, C-13
HDW13195	F-5
HDW3768	A-7
HDW3771	A-7
HDW5217	B-3, B-13, B-15, C-3, C-5, C-9, C-13, F-9, F-13
HDW5251	C-15
HDW5290	D-5
HDW5355	B-3, F-7
HDW5363	B-13
HDW5364	B-13
HDW5417	F-7
HDW5636	B-15
HDW5723	B-3, F-3, F-7, F-13
HDW5724	A-3, A-5, B-3, B-7, B-15, F-9, F-13

Part Number	Page
91678	F-15
91698	E-15
91709	F-9
91711	A-11
91716	E-7
91719	E-15
91720	E-9
91721	E-9, F-9
91728	G-11
91729	G-11
91730	G-11
91740	G-3, G-9
91744	A-11
91745	F-9
91748	F-9
91756	F-15
91757	F-15
91758	F-15
91759	F-15
91760	F-15
91761	F-15
91762	A-3, A-5
91780	F-15
9179	A-5
91804	E-19, E-21
91805	E-23
9183	A-5
9188	A-5
9227	E-13
9307	D-5
9367	F-9
9370	F-9
9386	E-11
9389	E-11
9411	F-15
9465	G-5, G-11
9549	A-11
9587	C-3, C-5, C-9, C-13
9607	D-5
9716	B-13
9781	D-7
9910	G-3, G-9
9920	E-15
9932	G-3

HDW5916	F-17
HDW5920	D-5, F-17
HDW5925	E-25
HDW5989	D-3
HDW5994	D-3, D-5
HDW6433	B-17, F-11
HDW6434	B-3, B-11
HDW6455	B-13, B-15, C-3, C-5, C-9, C-13, F-17
HDW6491	C-5, C-9, C-13
HDW6633	D-5, F-17
HDW6677	D-3, D-5
HDW6727	E-19, E-21, E-23
HDW7018	F-5
HDW7031	B-5

Part Number Index

Part Number	Page	Part Number	Page
HDW7043	D-5	HDW8856	B-3
HDW7052	F-17	HDW8876	E-25
HDW7061	E-3	HDW8877	E-5
HDW7119	B-3	HDW8881	D-3, E-5, E-9, E-25
HDW7120	B-11	HDW8899	C-3, C-5, C-9, C-13
HDW7314	E-3, E-9	HDW8974	B-3
HDW7326	D-5	HDW8984	D-3, D-5
HDW7391	E-17	HDW9037	D-3
HDW7438	E-3	HDW90409	D-3
HDW7593	B-3	HDW90410	D-5
HDW7601	E-9, E-19, E-21, E-23	HDW90764	E-5
HDW7881	A-7	HDW90770	D-5
HDW7887	A-7	HDW90803	A-3, A-5
HDW7888	A-7	HDW90879	A-3, A-5
HDW7938	F-17	HDW90943	E-21
HDW7971	E-5	HDW90945	E-21
HDW8152	E-19, E-21, E-23	HDW90951	F-5
HDW8267	B-3, B-15, C-15, F-3, F-7, F-9, F-11, F-13	HDW91081	E-5
HDW8268	B-3, B-11, B-17	HDW91235	D-3
HDW8273	C-15, F-9, F-13	HDW91236	D-5
HDW8279	B-3	HDW91240	E-19
HDW8283	F-3	HDW91243	E-5
HDW8284	C-3, C-5, C-9, C-13	HDW91244	E-5
HDW8294	A-3, A-5, B-3, B-11, C-3, C-5, C-9, C-13	HDW91245	E-5
HDW8303	B-5, B-11, C-3, C-5, C-9, C-13	HDW91246	E-15
HDW8304	B-3, B-5, B-15, C-3, C-5, C-9, C-13	HDW91248	E-5
HDW8370	B-7	HDW91267	F-11
HDW8399	A-7	HDW91328	F-17
HDW8455	A-9	HDW91334	E-5
HDW8457	B-3, C-3, C-5, C-9, C-13, D-5, F-3, F-5, F-17	HDW91395	F-17
HDW8476	E-27	HDW91465	E-27
HDW8482	C-15, F-9	HDW91500	B-15
HDW8486	B-11	HDW9157	E-5
HDW8498	F-17	HDW9200	F-9
HDW8501	B-15	HDW9219	D-5, F-17
HDW8513	B-5	HDW9268	F-9
HDW8531	A-7, F-3	HDW9557	E-13, E-17
HDW8567	A-7	HDW9761	E-27
HDW8568	D-5		



Part Number Index

Part Number Page

Part Number Page





Service Parts Order Form

Fax to 559-263-9631

Please fill out completely

Date: _____

Ordered By: _____

Account: _____

Your Fax No.: _____

Bill to: _____

Ship to: _____

Purchase Order Number _____

Ship VIA _____

**All orders MUST have a Purchase Order Number

**Fed Ex shipments require Fed Ex account number

Part Number	Description	Quantity	Price

All backordered parts will be shipped when available via the same ship method as original order unless noted below:

- Ship complete order only - no backorders
- Ship all available parts and contact customer on disposition of backordered parts
- other (please specify)

NOTES:



Limited Owner Warranty

MEC Aerial Platform Sales Corp. warrants its equipment to the original purchaser against defects in material and/or workmanship under normal use and service for one (1) year from date of registered sale or date the unit left the factory if not registered. MEC Aerial Platform Sales Corp. further warrants the structural weldments of the main frame and scissor arms to be free from defects in material or workmanship for five (5) years from date of registered sale or date unit left the factory if not registered. Excluded from such warranty is the battery(s) which carries a ninety (90) day warranty from described purchase date. Warranty claims within such warranty period shall be limited to repair or replacement, MEC Aerial Platform Sales Corp's option, of the defective part in question and labor to perform the necessary repair or replacement based on MEC Aerial Platform Sales Corp's then current flat rate, provided the defective part in question is shipped prepaid to MEC Aerial Platform Sales Corp. and is found upon inspection by MEC Aerial Platform Sales Corp. to be defective in material and/or workmanship. MEC Aerial Platform Sales Corp. shall not be liable for any consequential, incidental or contingent damages whatsoever. Use of other than factory authorized parts; misuse, improper maintenance, or modification of the equipment voids this warranty. The foregoing warranty is exclusive and in lieu of all other warranties, express or implied. All such other warranties, including implied warranties of merchantability and of fitness for a particular purpose, are hereby excluded. No Dealer, Sales Representative, or other person purporting to act on behalf of MEC Aerial Platform Sales Corp. is authorized to alter the terms of this warranty, or in any manner assume on behalf of MEC Aerial Platform Sales Corp. any liability or obligation which exceeds MEC Aerial Platform Sales Corp's obligations under this warranty.



Aerial Platform Sales Corp.

1775 Park Street, Suite 77 • Selma, CA 93662 USA
Ph: 1-800-387-4575 • 559-891-2488 • Fax: 559-891-2448
E-mail: info@mecawp.com • Web: www.mecawp.com