

3084RT - Diesel/Dual Fuel Models

Hydraulic - 3084RT

The following table applies to the next 3 pages.

Callout	Description
MA-1	MAIN MANIFOLD
CBV1	Counter Balance Valve, Drive
CBV2	Counter Balance Valve, Drive
CL1	Coil - Speed/Torque/Steer Valves #8
CL2	Coil - Lift Valve #10
CV1	Check Valve, Load Sense Steer Left
CV2	Check Valve, Load Sense Steer Right
EC1	Priority Flow Control
EP1	Piloted Poppet Valve - Torque/Speed
EP2	Piloted Poppet Valve - Torque/Speed
FD1	Flow Divider/Combiner
FD2	Flow Divider/Combiner
HP1	Hand Pump, Brake Release
LS1	Load Sense Shuttle Valve
LS2	Load Sense Shuttle Valve
LS3	Load Sense Shuttle Valve
MP1	Manual Push Brake Release Valve
OD1	Orifice Disc, Brakes, 0.035
OPL1	Orifice Plug, Steering, 0.087
OPL2	Orifice Plug, Flow Divider Bleed, 0.025
OPL3	Orifice Plug, Flow Divider Bleed, 0.025
ORF1	Orifice, Steering, 0.064
ORF2	Orifice, Lift, 0.093
PD1	Pilot Valve, Series Parallel, 4-Way / 3-Position
PD2	Pilot Valve, Series Parallel, 4-Way / 3-Position
PD3	Pilot Valve, Series Parallel, 4-Way / 3-Position
PLG4	Port Plug
PLG6	Port Plug
RV1	Relief Valve, Lift, 2500 PSI
RV2	Relief Valve, Steering, 2000 PSI
SP1	Proportional Valve
SV1	Spool Valve, Lift, 3-Way
SV2	Spool Valve, Steer, 4-Way / 3-Position
SV3	Spool Valve, Series Parallel, 4-Way / 3-Position
SV4	Spool Valve, Series Parallel, 4-Way / 3-Position
SVD1	Spool Valve, Drive, 4-Way / 3-Position

Callout	Description
	STEERING COMPONENTS
CYL1	Steer Cylinder, Right
CYL2	Steer Cylinder, Left
	TILT COMPONENTS
MA-2	Combination Valve Manifold - Tilt
CV3	Check Valve, Tilt, Side/Side Load Sense
CV4	Check Valve, Tilt, Front/Rear Load Sense
CV5	Check Valve, 10 PSI Oscillating axle
CV6	Check Valve, Tilt Cyl, Front/Rear
CV7	Check Valve, Tilt Cyl, Front/Rear
CV8	Check Valve, Tilt Cyl, Side/Side
CV9	Check Valve, Tilt Cyl, Side/Side
CYL4	Tilt Cylinder, Front/Rear
CYL5	Tilt Cylinder, Side/Side
CYL6	Axle Lock Cylinder
CYL7	Axle Lock Cylinder
ORF4	Orifice, 0.040, Tilt, Side/Side
ORF5	Orifice, 0.040, Tilt, Front/Rear
RV3	Relief Valve, Tilt Cyl Front/Rear, 2500 PSI
RV4	Relief Valve, Tilt Cyl Front/Rear, 2500 PSI
RV5	Relief Valve, Tilt Cyl Side/Side, 2500 PSI
RV6	Relief Valve, Tilt Cyl Side/Side, 2500 PSI
SV8	Spool Valve, Tilt Front/Rear
SV9	Spool Valve, Tilt Side/Side
	LIFT COMPONENTS
MA-3	Lift Cylinder Manifold
CYL3	Lift Cylinder
ORF3	Orifice, 0.067 Descend
SV5	Solenoid Valve, 12V, Dual Coil
	Wheel Motors
LF	Wheel Motor - Left Front
LR	Wheel Motor w/ Brake - Left Rear
RF	Wheel Motor - Right Front
RR	Wheel Motor w/ Brake - Right Rear
SV6	Spool Valve - Right Wheel Motor Bypass
SV7	Spool Valve - Left Wheel Motor Bypass
	RESERVOIR
FL1	Filter, 10 Micron, Fluid Return
P1	Pump, Hydraulic Fluid

3084RT - Hydraulic Schematic

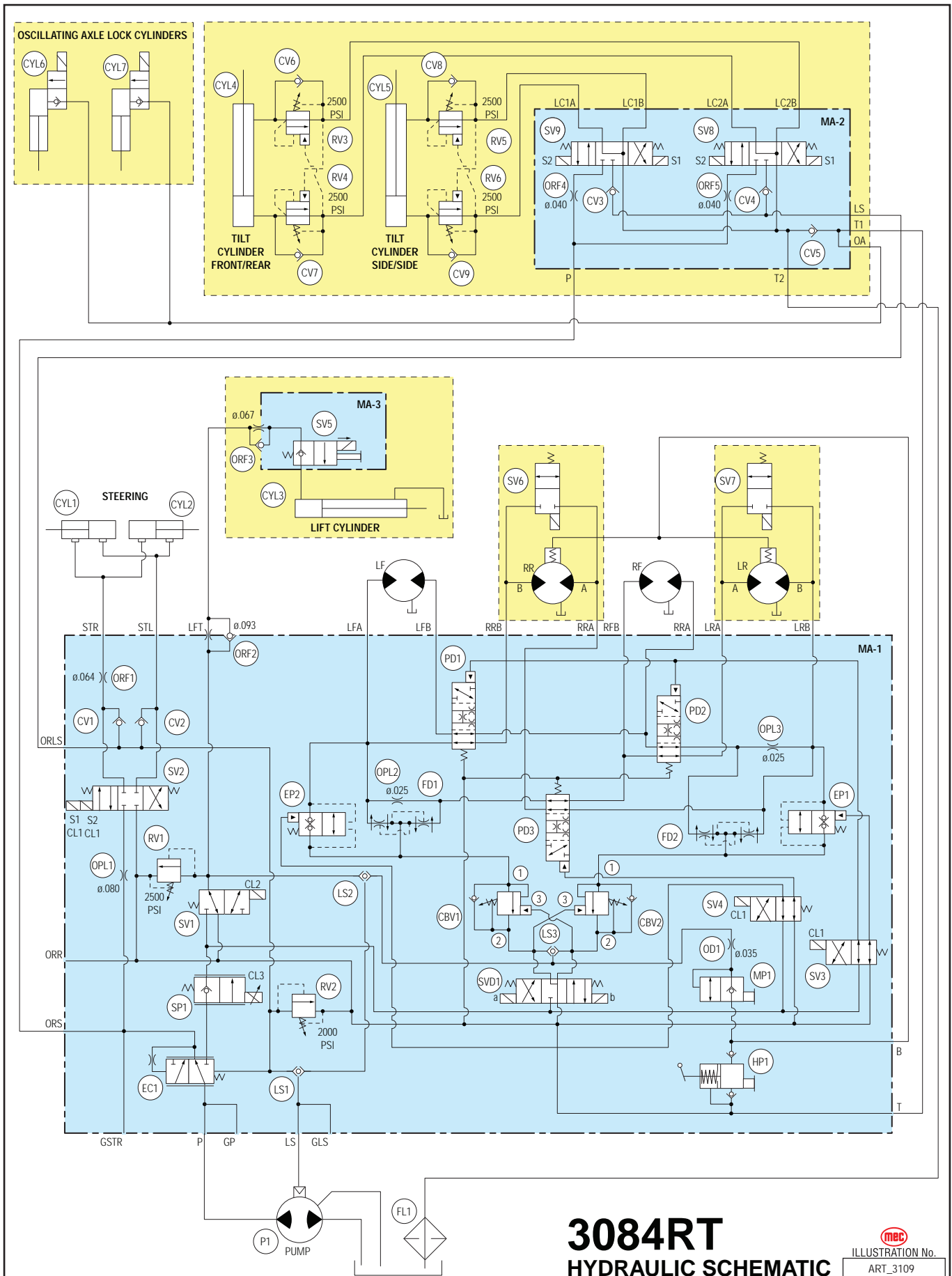

3084RT HYDRAULIC SCHEMATIC

ILLUSTRATION No.
ART_3109



3084RT - Hydraulic Manifold Main M1

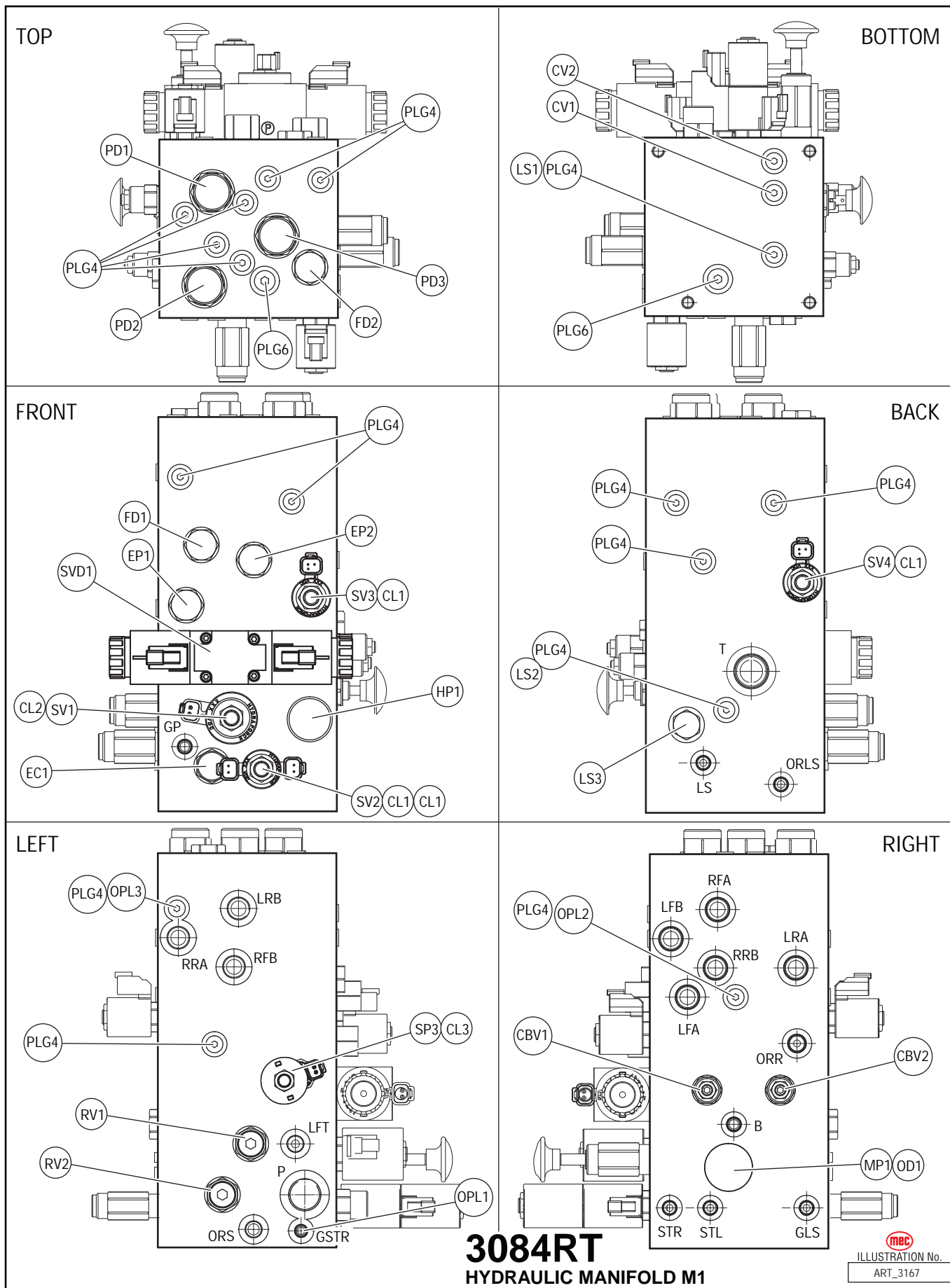

3084RT
HYDRAULIC MANIFOLD M1

ILLUSTRATION No.
ART_3167



3084 All Models - Hydraulic Manifold Tilt M2

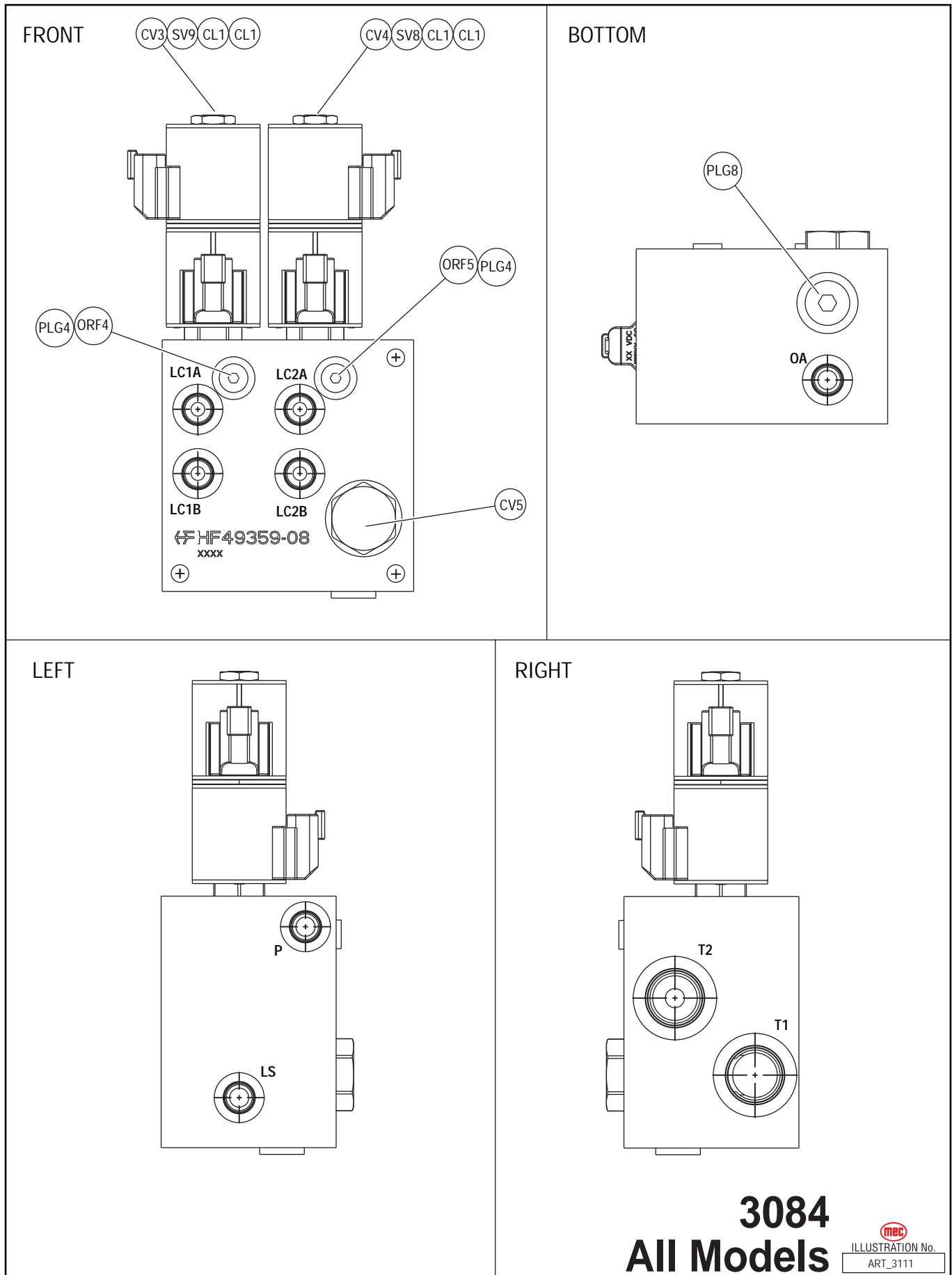

3084RT - Upper Controls Electric Schematic

MEC SCHEMATIC	
Model: / Serial # 3084RT 11800025- UP	
Upper Controls	
GP400: 21 510 411	
Reference Art #: none	Publication Art #: ART_3112

3084RT

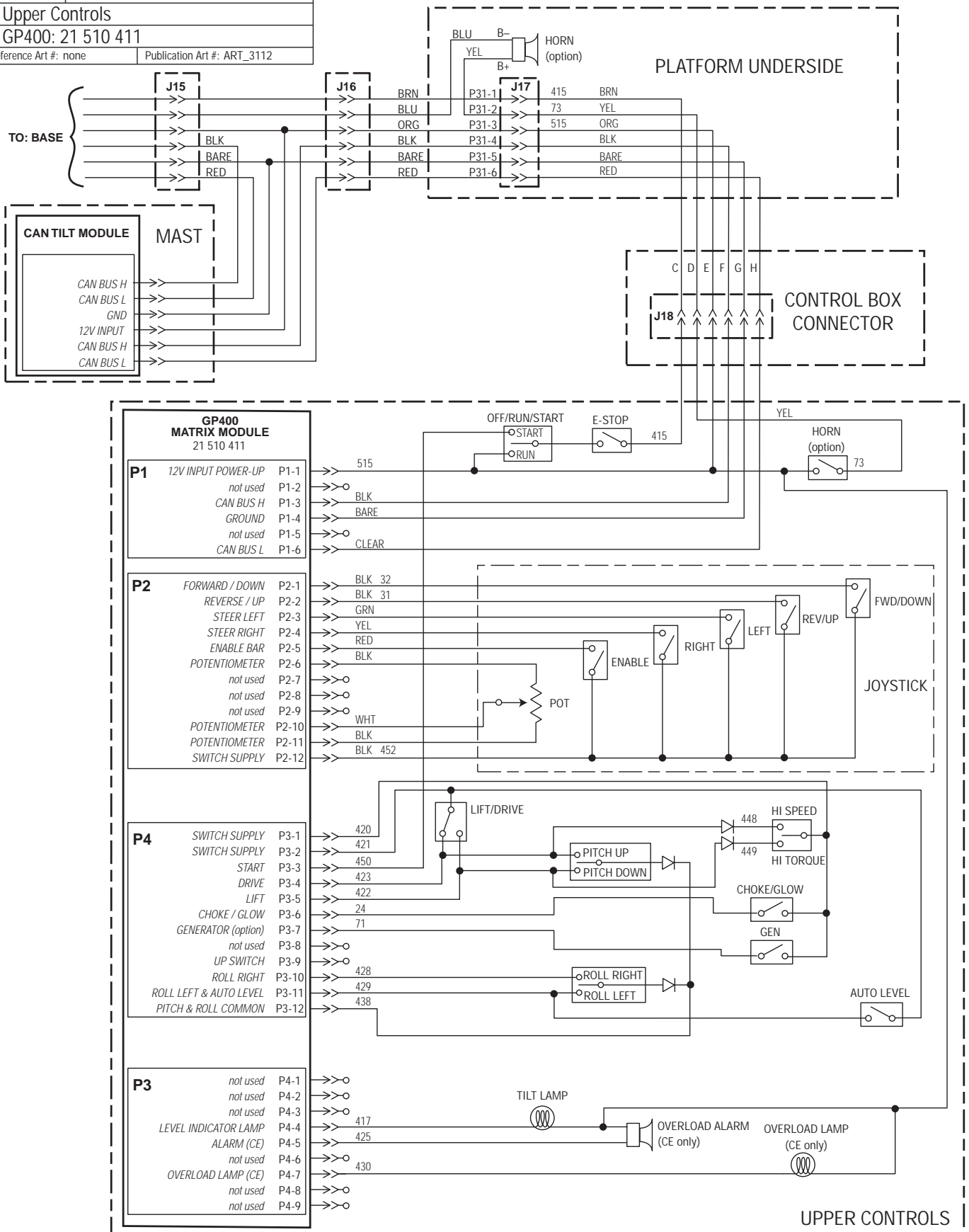

3084RT - Upper Controls Components

3084RT ANSI

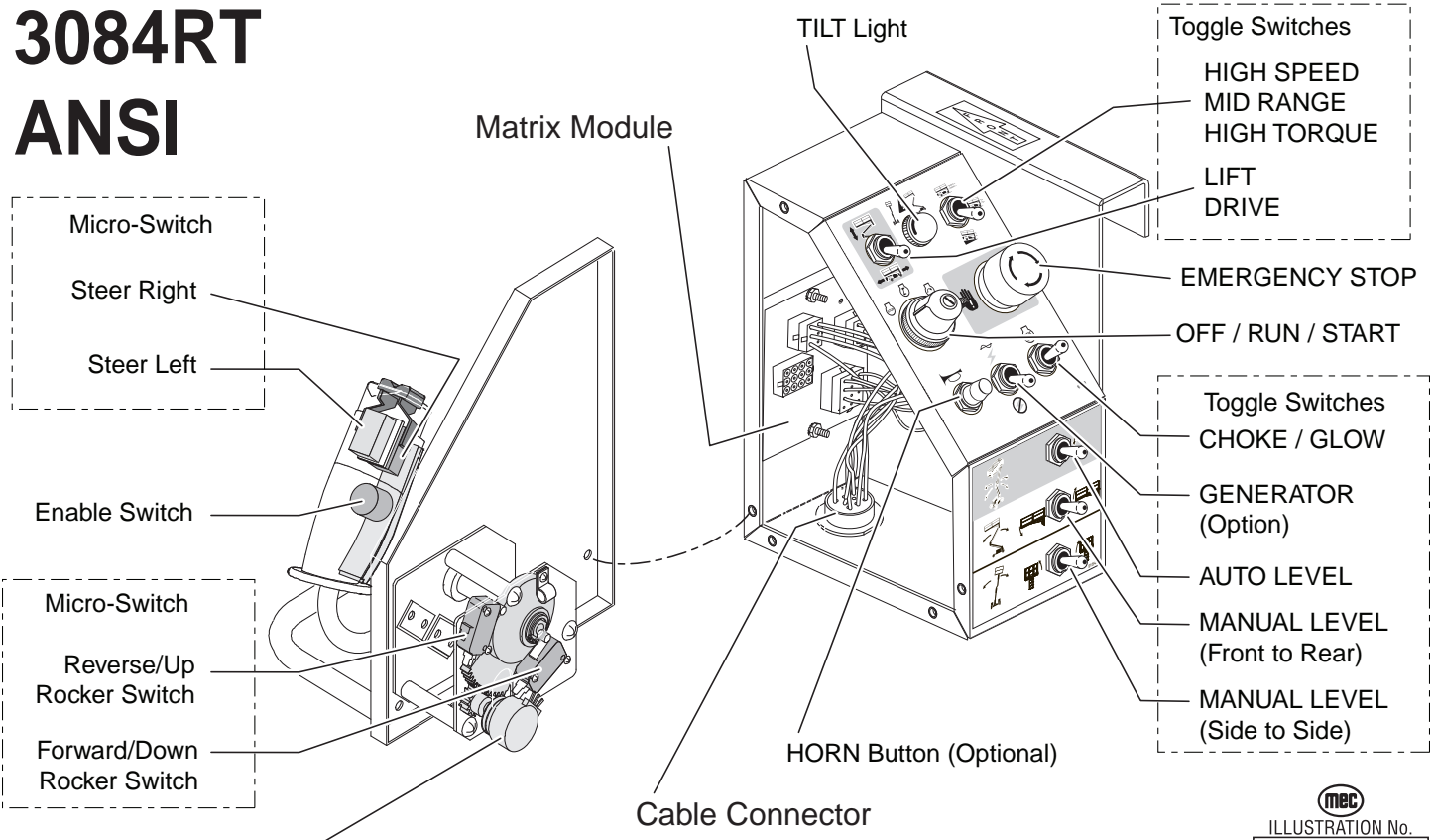

mec
ILLUSTRATION No.
ART_3192

3084RT CE

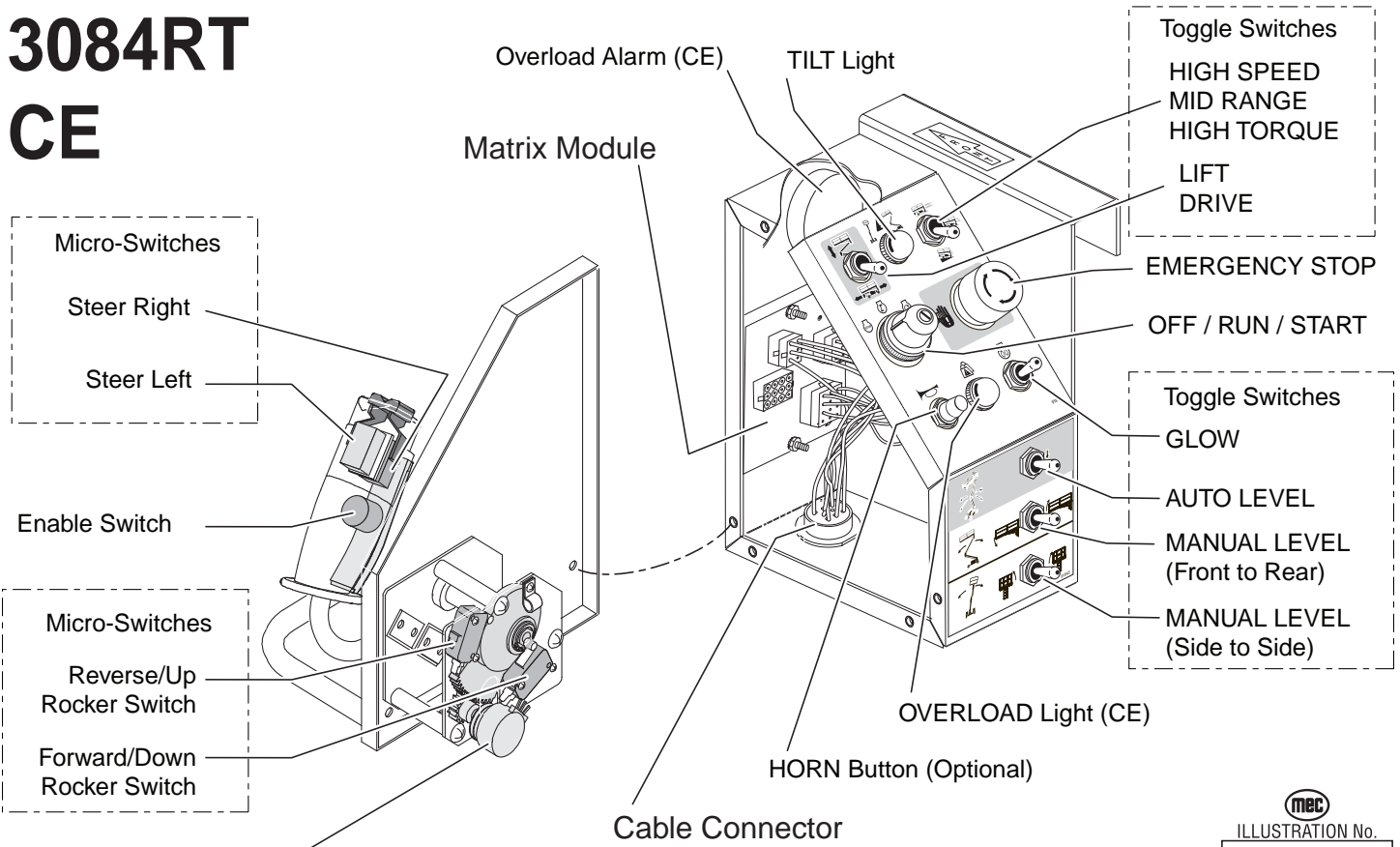

mec
ILLUSTRATION No.
ART_3194



3084RT Dual Fuel - Lower Control Box Electric Schematic

mec SCHEMATIC
Model / Serial #
3084 | Serial #11800025 - UP
Lower Control Box - Dual Fuel
Reference Art #: none | Publication Art #: ART_3195

3084RT DUAL FUEL

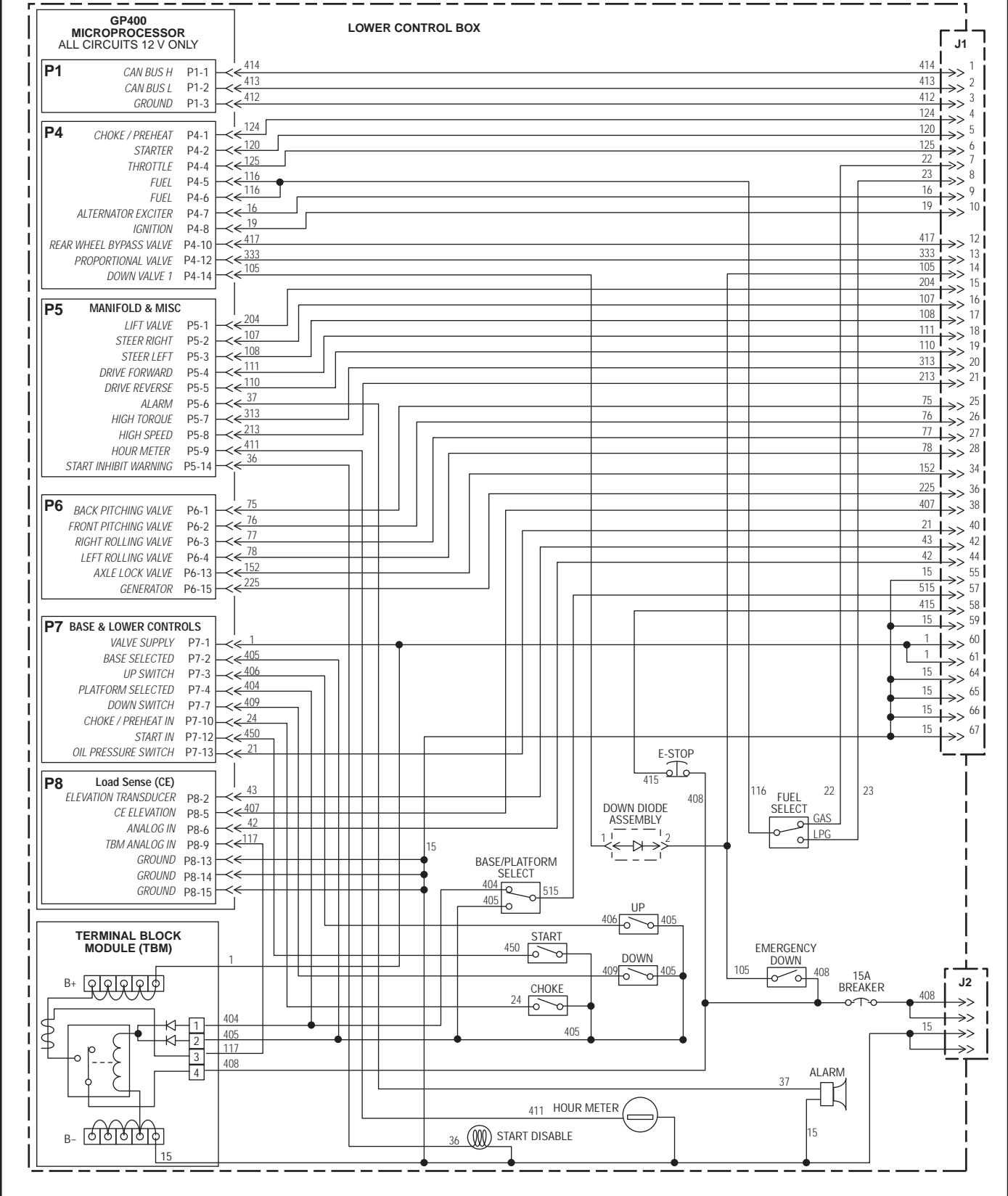

3084RT Dual Fuel - Base Electric Schematic

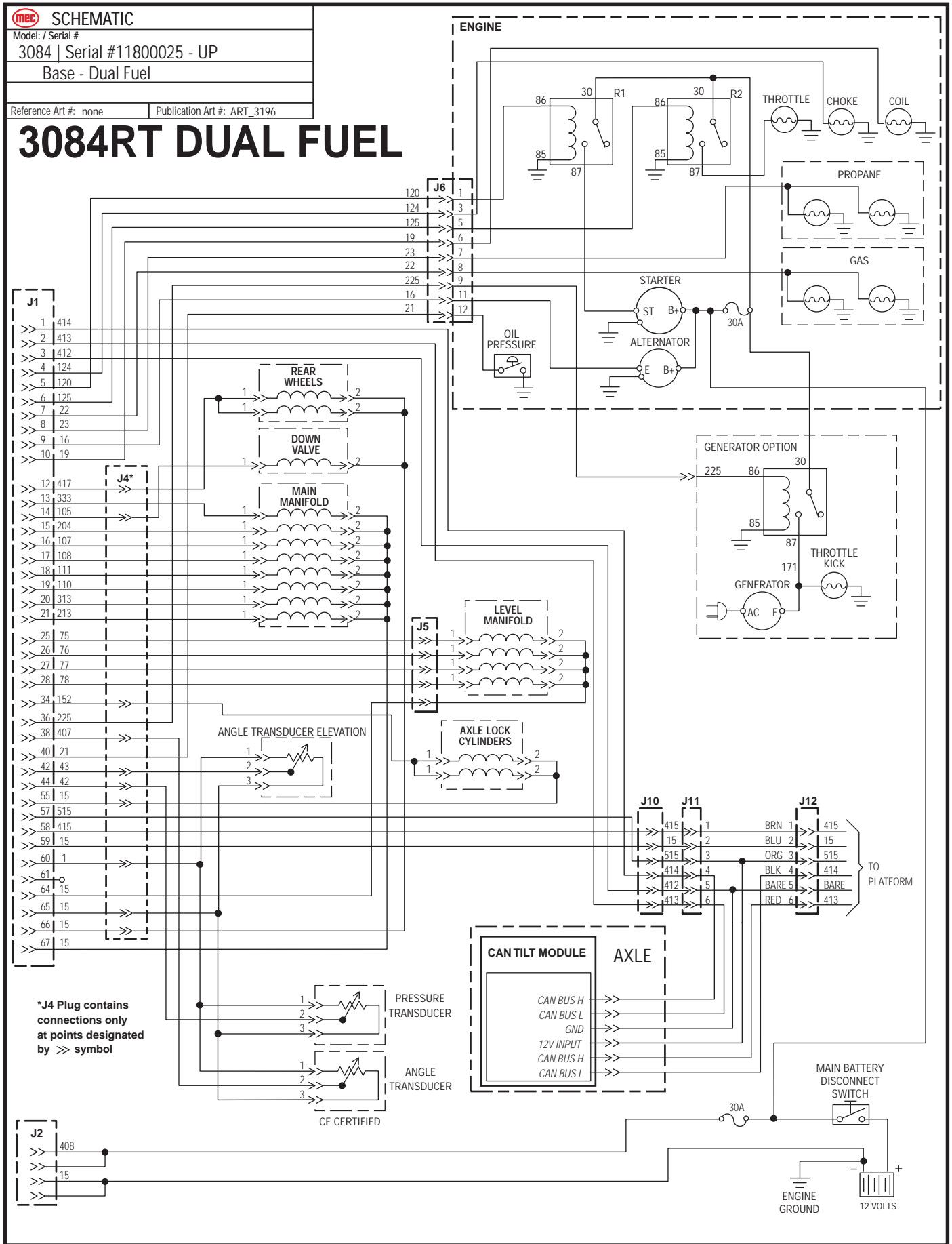

3084RT Diesel - Lower Control Box Electric Schematic

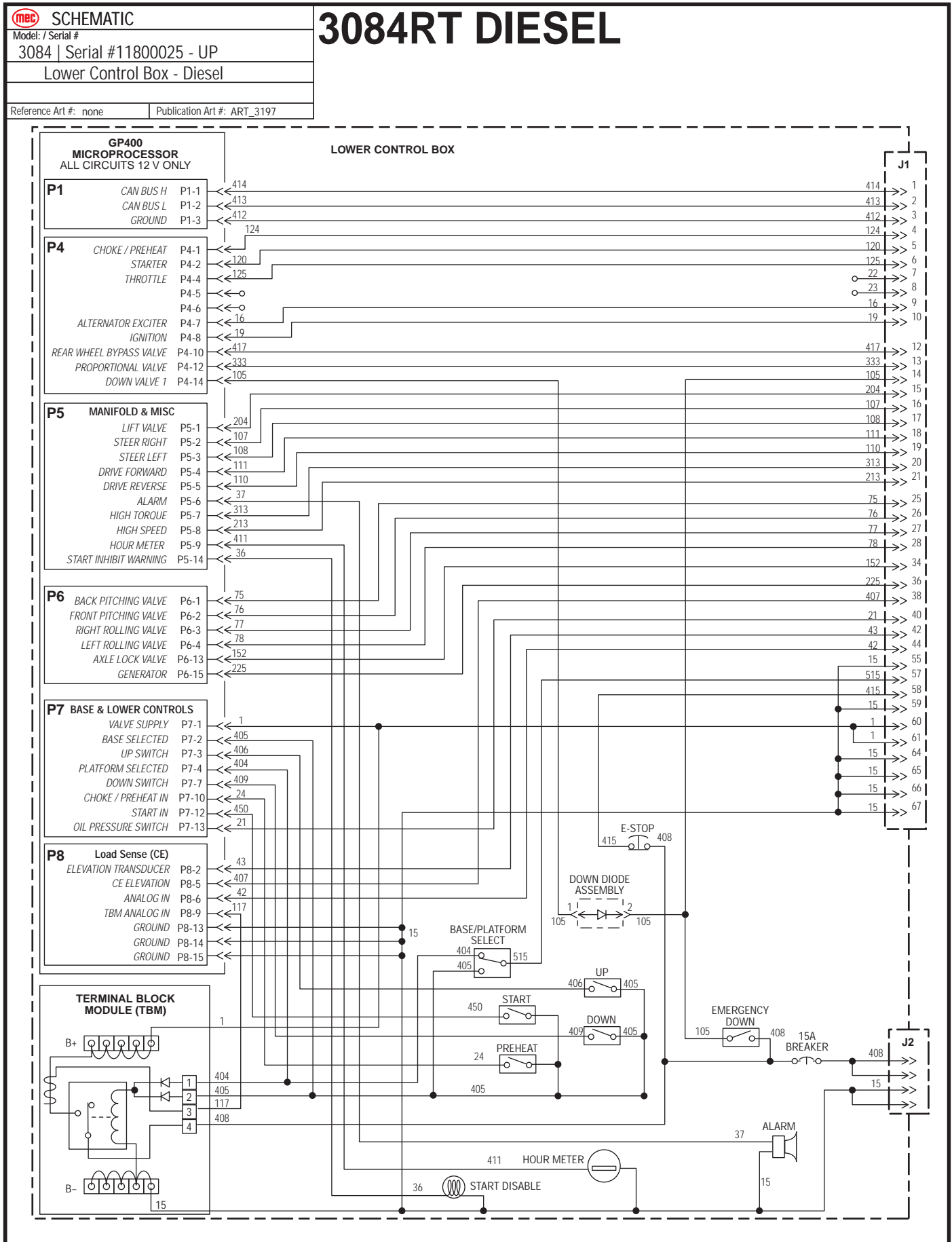

3084RT Diesel - Base Electric Schematic

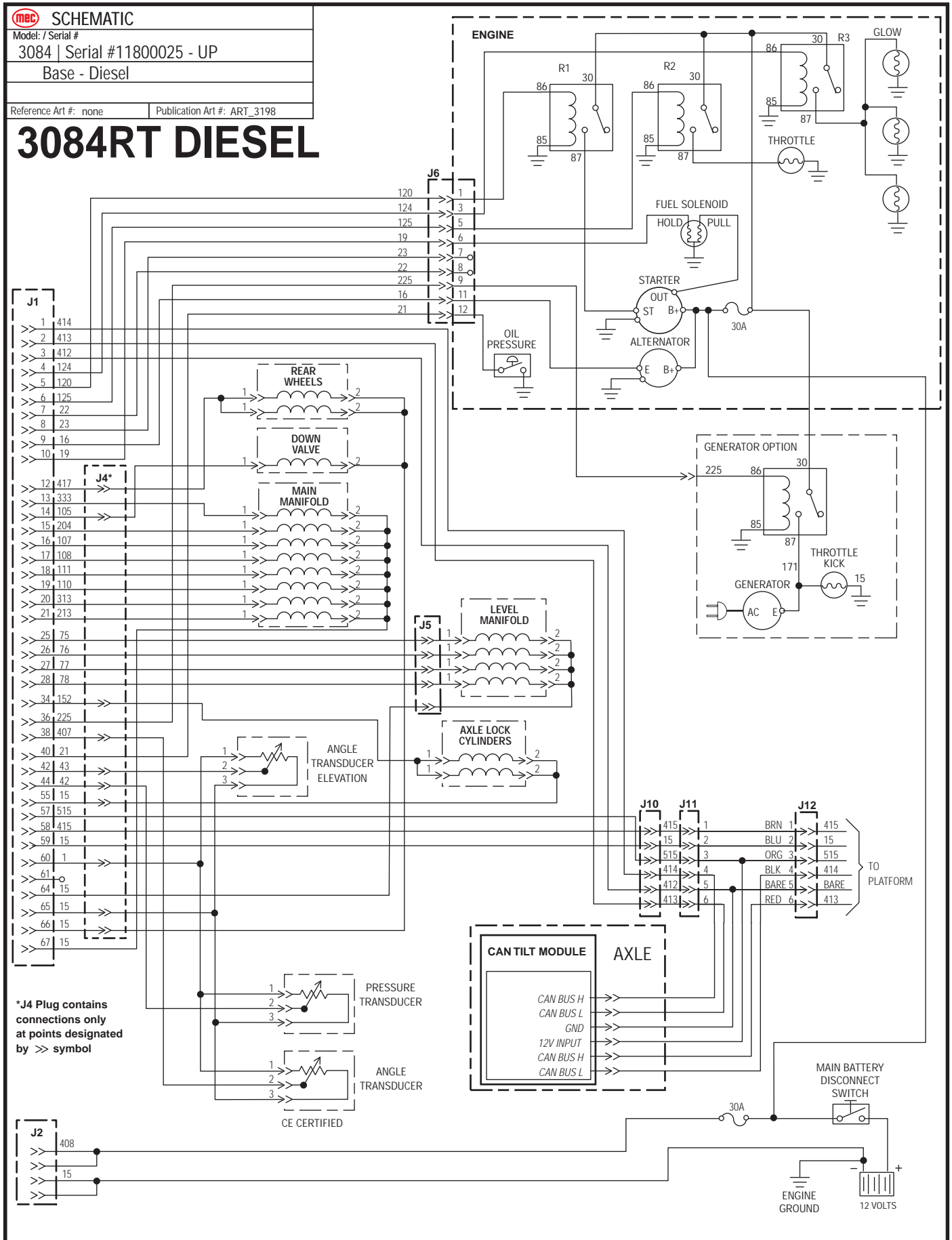

3084RT - Lower Controls Components

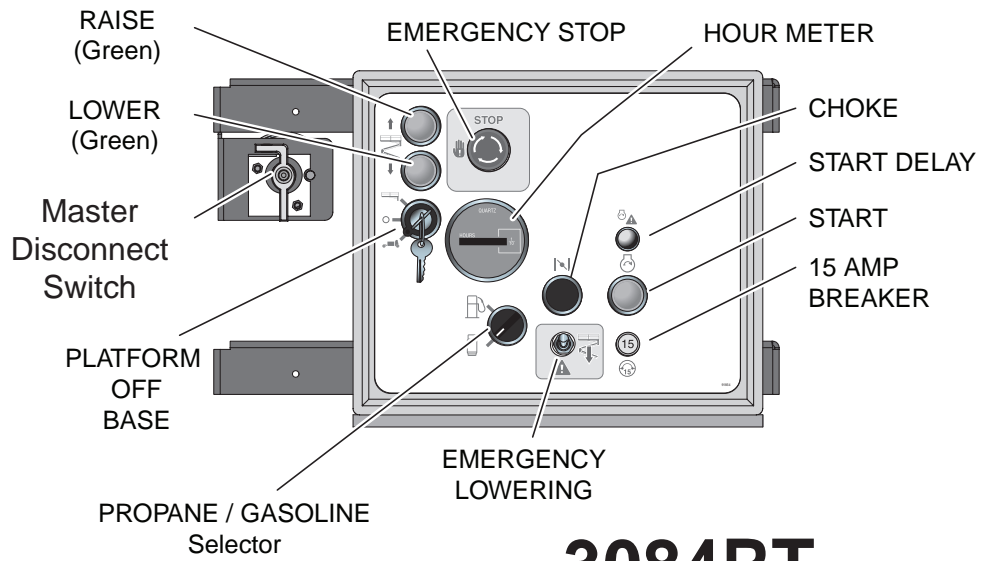
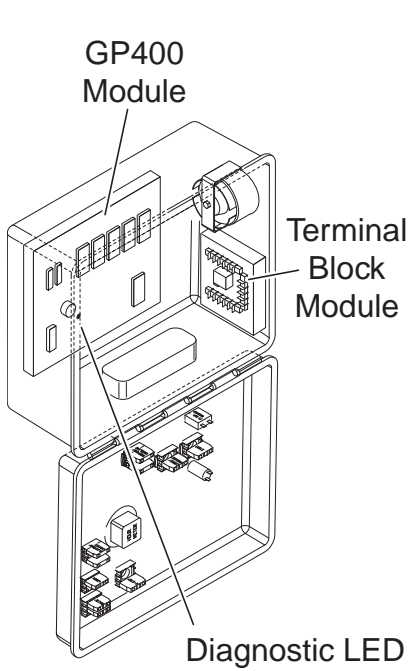

3084RT Dual Fuel - ANSI

mec
ILLUSTRATION No.
ART_3193

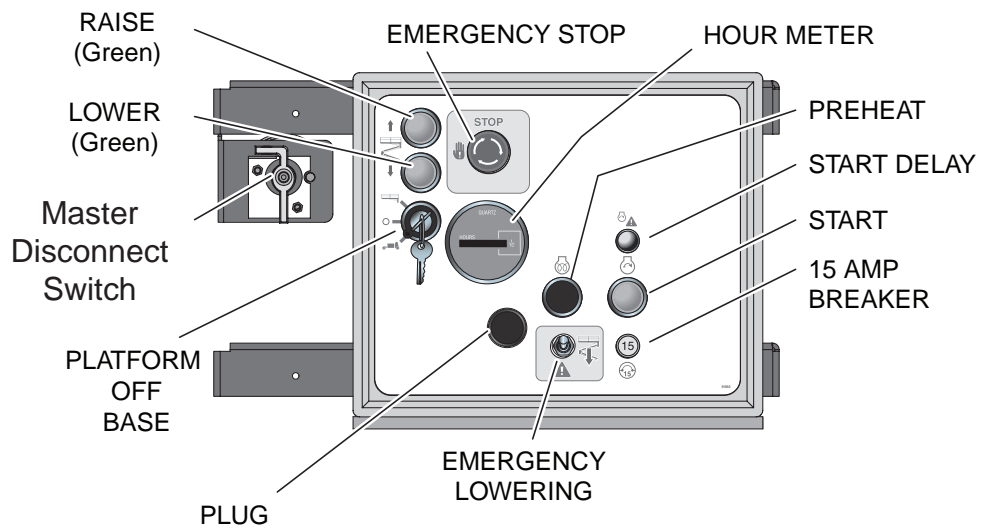
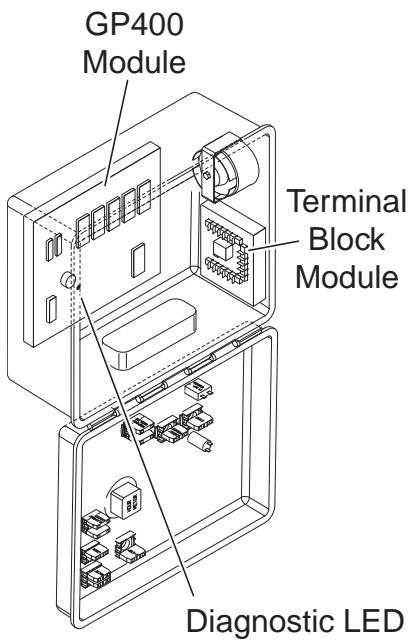

3084RT Diesel - ANSI/CE

mec
ILLUSTRATION No.
ART_3203

3084ES - Electric Model

Hydraulic - 3084ES

The following table applies to page 174 - 176.

Callout	Description
MA-1	MAIN MANIFOLD
CBV1	Counter Balance Valve, Drive
CBV2	Counter Balance Valve, Drive
CL1	Coil - Speed/Torque/Steer #8
CL2	Coil - Lift Valve #10
CL3	Coil - Proportional
CP1	Cavity Plug, Stopped
CV1	Check Valve, Load Sense Steer
EC1	Priority Flow Control
EP1	Piloted Poppet Valve - Torque/Speed
EP2	Piloted Poppet Valve - Torque/Speed
FD1	Flow Divider/Combiner
FD2	Flow Divider/Combiner
HP1	Hand Pump, Brake Release
LS1	Load Sense Shuttle
MP1	Manual Push Brake Release Valve
OD1	Orifice Disc, Brakes, 0.035
OPL1	Orifice Plug, Steering, 0.087
OPL2	Orifice Plug, Flow Divider Bleed, 0.025
OPL3	Orifice Plug, Flow Divider Bleed, 0.025
OPL4	Orifice Plug, Stopped
OPL5	Orifice Plug, Stopped
PD1	Pilot Valve, Series Parallel, 4-Way / 3-Position
PD2	Pilot Valve, Series Parallel, 4-Way / 3-Position
PD3	Pilot Valve, Series Parallel, 4-Way / 3-Position
PLG4	Port Plug
PLG6	Port Plug
RV1	Relief Valve, Lift, 2500 PSI
RV2	Relief Valve, Steering, 2000 PSI
RV7	Relief Valve, 3000 PSI Main
SV1	Spool Valve, Lift, 3-Way
SV2	Spool Valve, Steer, 4-Way / 3-Position
SV3	Spool Valve, Series Parallel, 4-Way / 3-Position
SV4	Spool Valve, Series Parallel, 4-Way / 3-Position
SVD1	Spool Valve, Drive, 4-Way / 3-Position

Callout	Description
	STEERING COMPONENTS
CYL1	Steer Cylinder, Right
CYL2	Steer Cylinder, Left
	TILT COMPONENTS
MA-2	Combination Valve Manifold - Tilt
CV3	Check Valve, Tilt, Side/Side Load Sense
CV4	Check Valve, Tilt, Front/Rear Load Sense
CV5	Check Valve, 10PSI Oscillating Axle
CV6	Check Valve, Tilt Cyl, Front/Rear
CV7	Check Valve, Tilt Cyl, Front/Rear
CV8	Check Valve, Tilt Cyl, Side/Side
CV9	Check Valve, Tilt Cyl, Side/Side
CYL4	Tilt Cylinder, Front/Rear
CYL5	Tilt Cylinder, Side/Side
CYL6	Axle Lock Cylinder
CYL7	Axle Lock Cylinder
ORF4	Orifice, 0.040, Tilt, Side/Side
ORF5	Orifice, 0.040, Tilt, Front/Rear
RV3	Relief Valve, Tilt Cyl Front/Rear, 2500 PSI
RV4	Relief Valve, Tilt Cyl Front/Rear, 2500 PSI
RV5	Relief Valve, Tilt Cyl Side/Side, 2500 PSI
RV6	Relief Valve, Tilt Cyl Side/Side, 2500 PSI
SV8	Spool Valve, Tilt Front/Rear
SV9	Spool Valve, Tilt Side/Side
	LIFT COMPONENTS
MA-3	Lift Cylinder Manifold
CYL3	Lift Cylinder
ORF3	Orifice, 0.067 Descend
SV5	Solenoid Valve, 12V, Dual Coil
	WHEEL MOTORS
LF	Wheel Motor - Left Front
LR	Wheel Motor w/ Brake - Left Rear
RF	Wheel Motor - Right Front
RR	Wheel Motor w/ Brake - Right Rear
SV6	Spool Valve - Right Wheel Motor Bypass
SV7	Spool Valve - Left Wheel Motor Bypass
	RESERVOIR
FL1	Filter, 10 Micron, Fluid Return
P1	Pump, Hydraulic Fluid

3084ES - Hydraulic Schematic

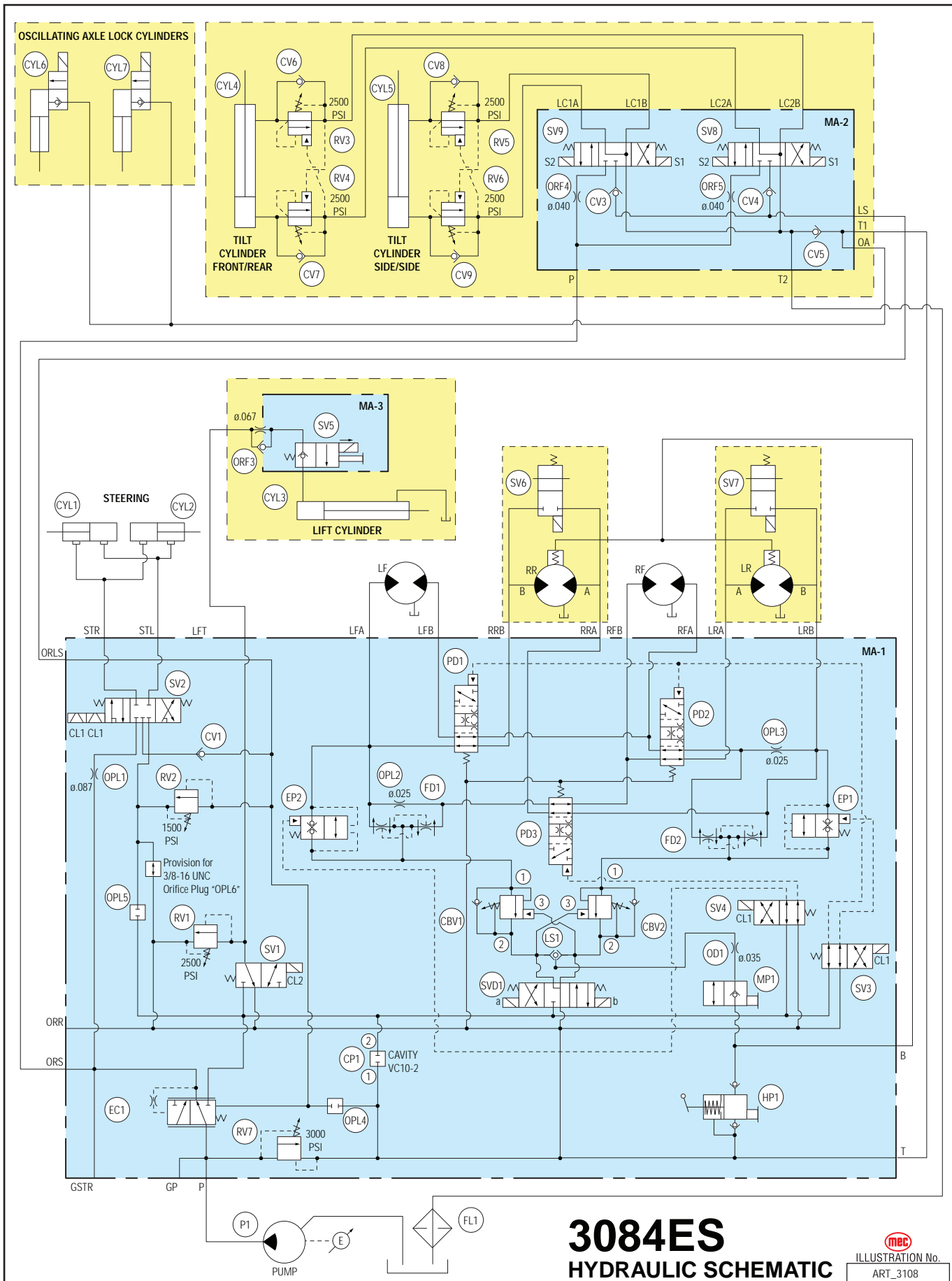

3084ES
HYDRAULIC SCHEMATIC

ILLUSTRATION No.
ART_3108



3084ES - Hydraulic Manifold Main M1

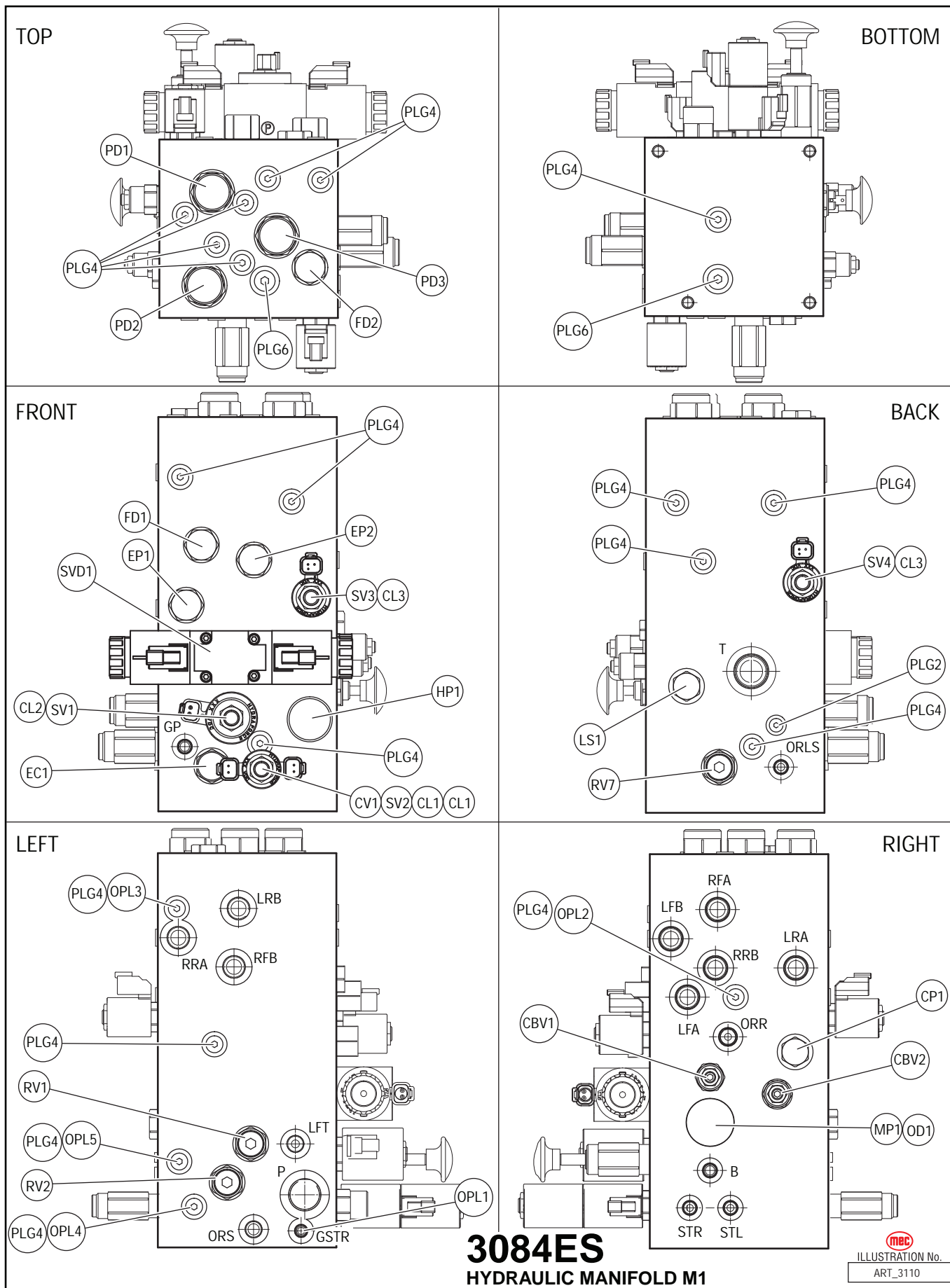

3084ES HYDRAULIC MANIFOLD M1

ILLUSTRATION No.
ART_3110

3084 All Models - Hydraulic Manifold Tilt M2

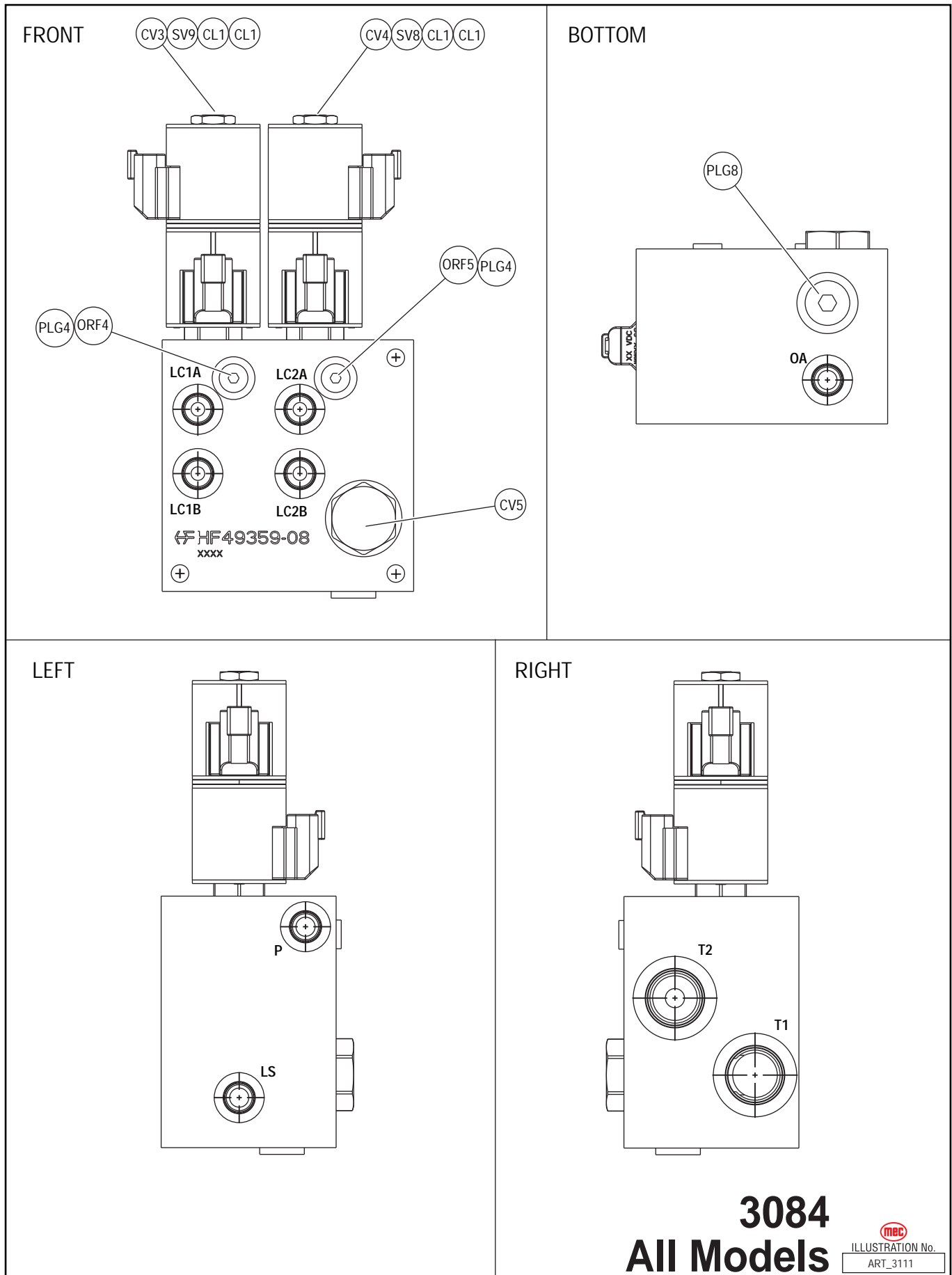

3084ES - Upper Controls Electric Schematic

SCHEMATIC	
Model: / Serial #	
3084ES 11800025- UP	
Upper Controls	
GP400: 21 510 411	
Reference Art #: none	Publication Art #: ART_3287

3084ES

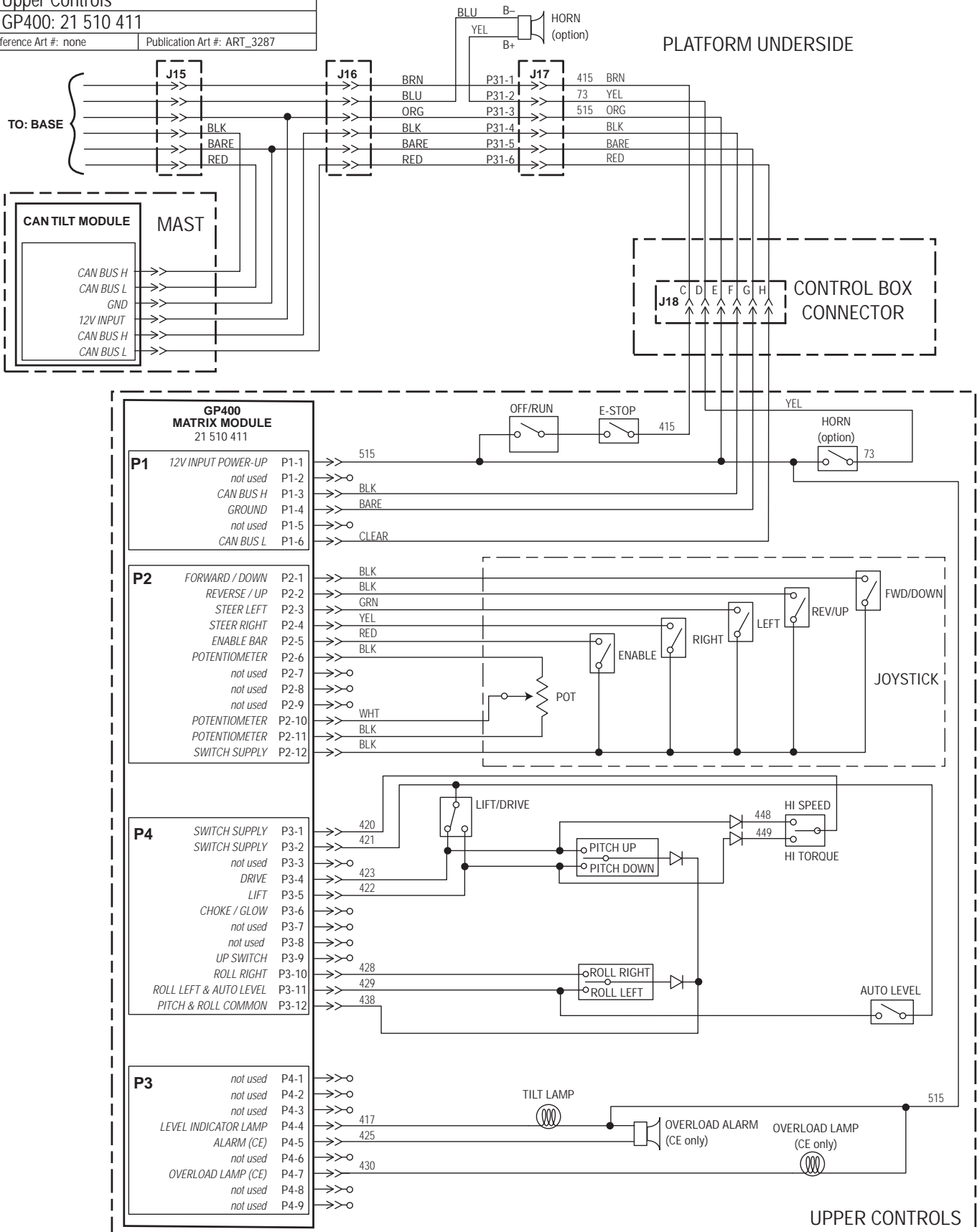

3084ES - Upper Controls Components

3084ES ANSI

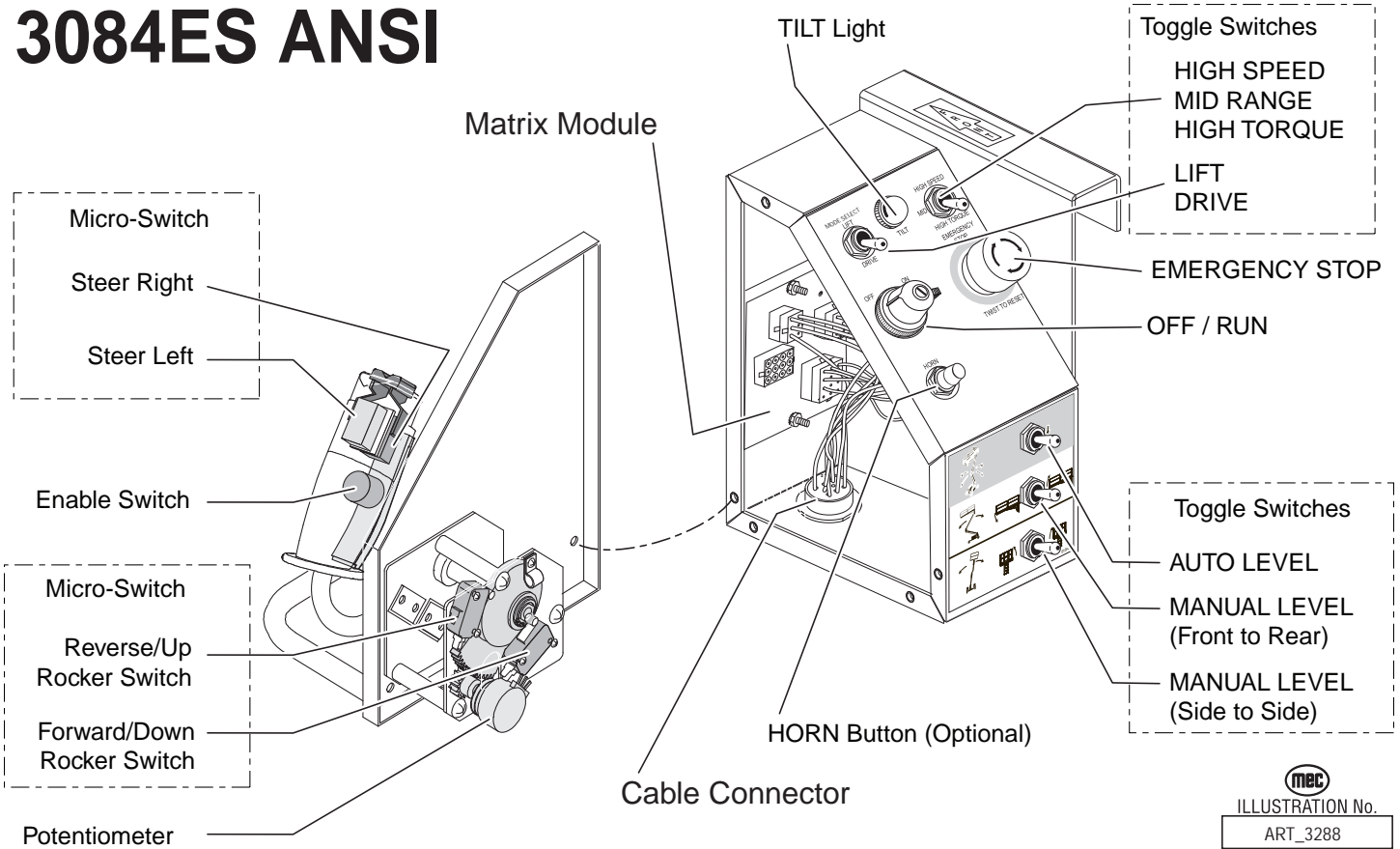

3084ES CE

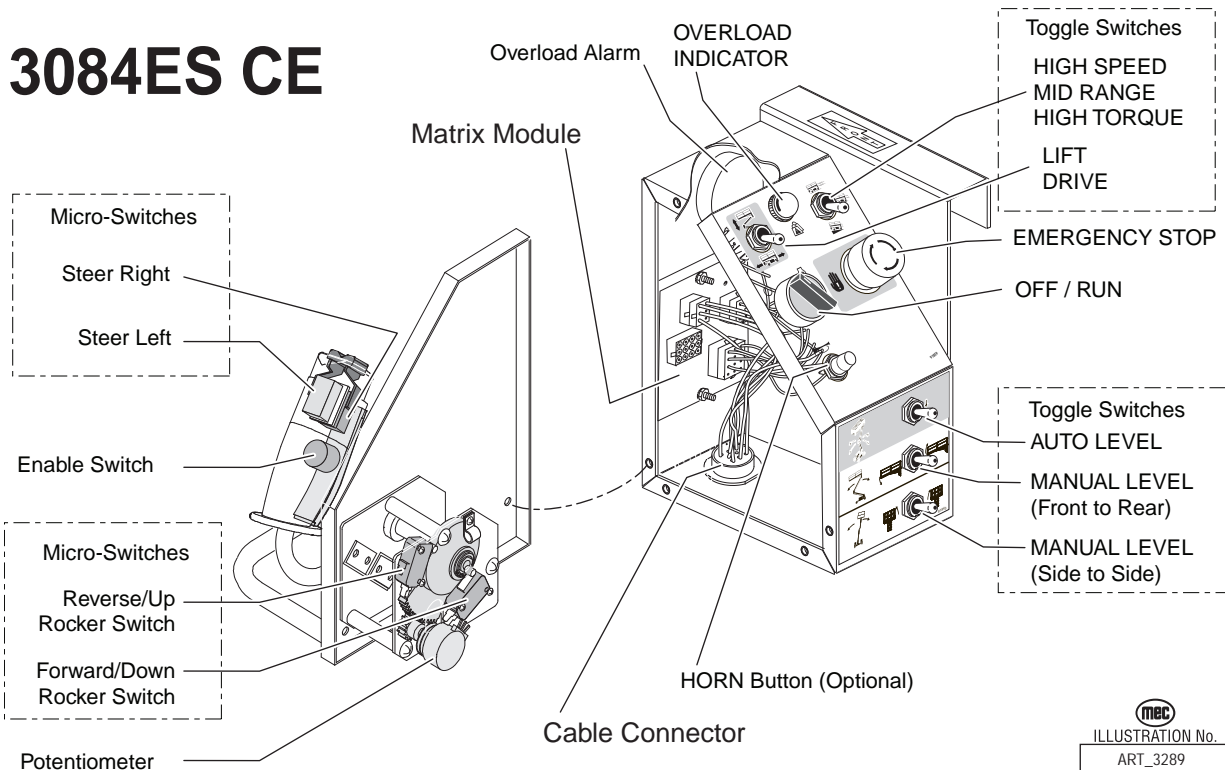

3084ES - Lower Control Box Electric Schematic

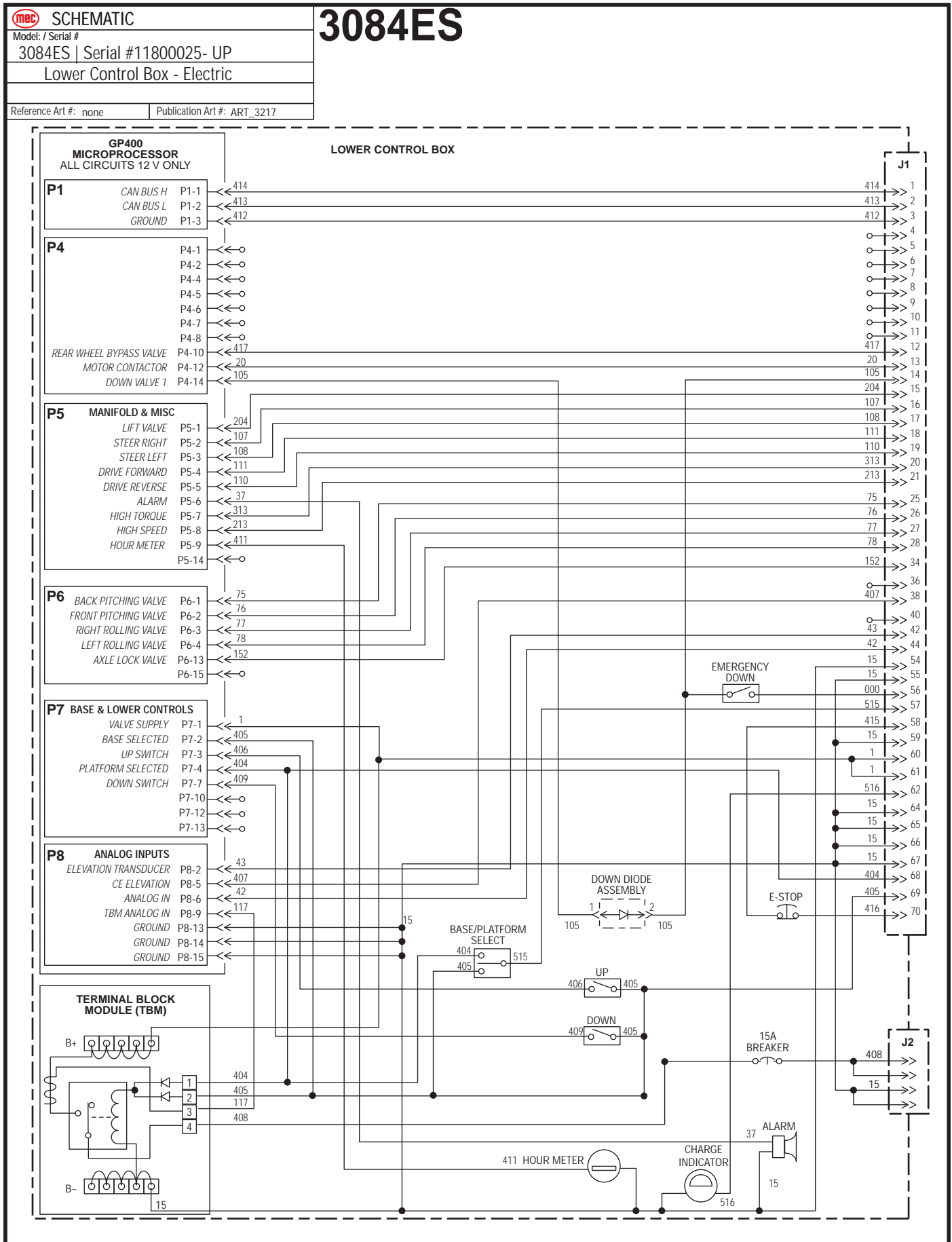

3084ES - Base Electric Schematic

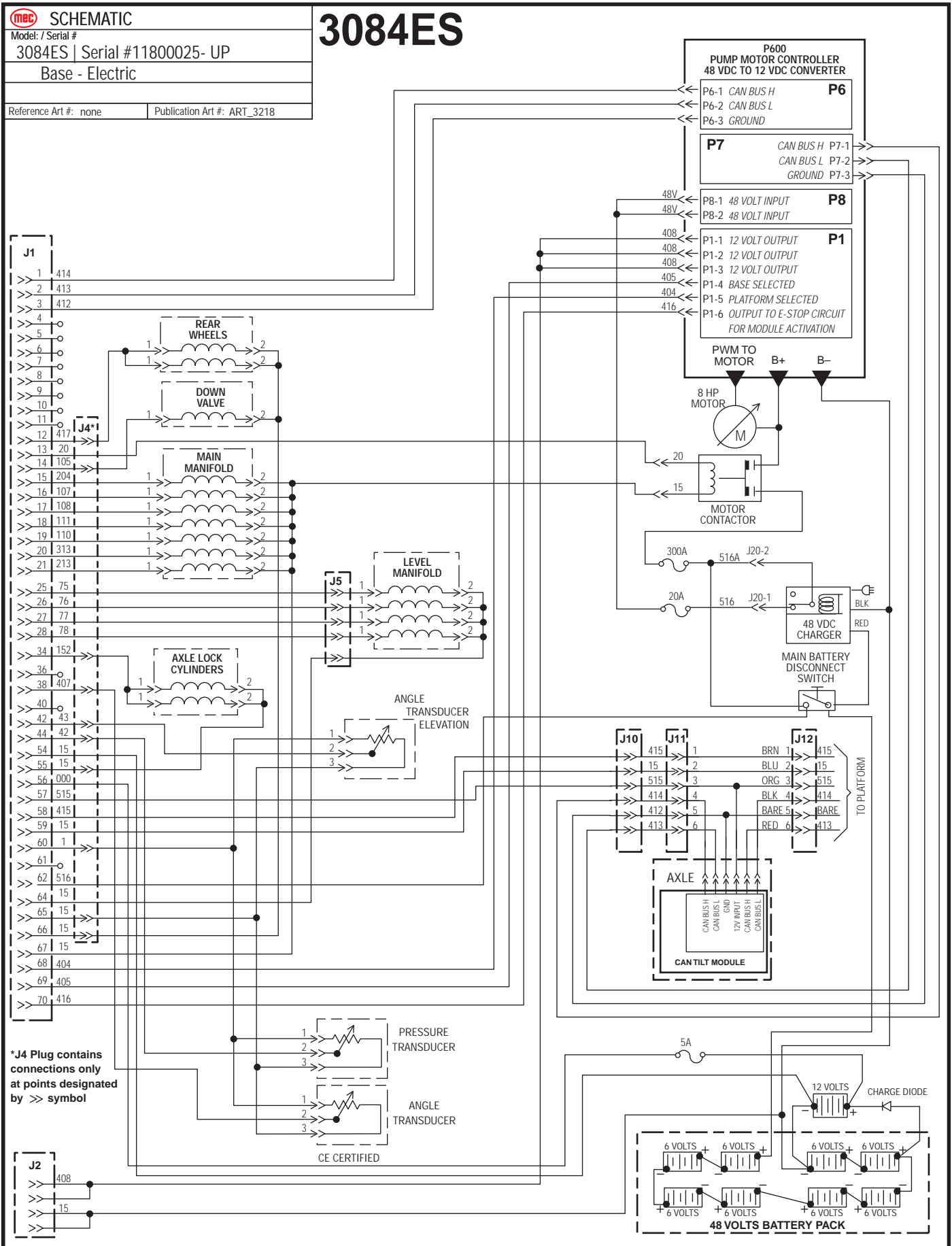

3084ES - Lower Controls Components

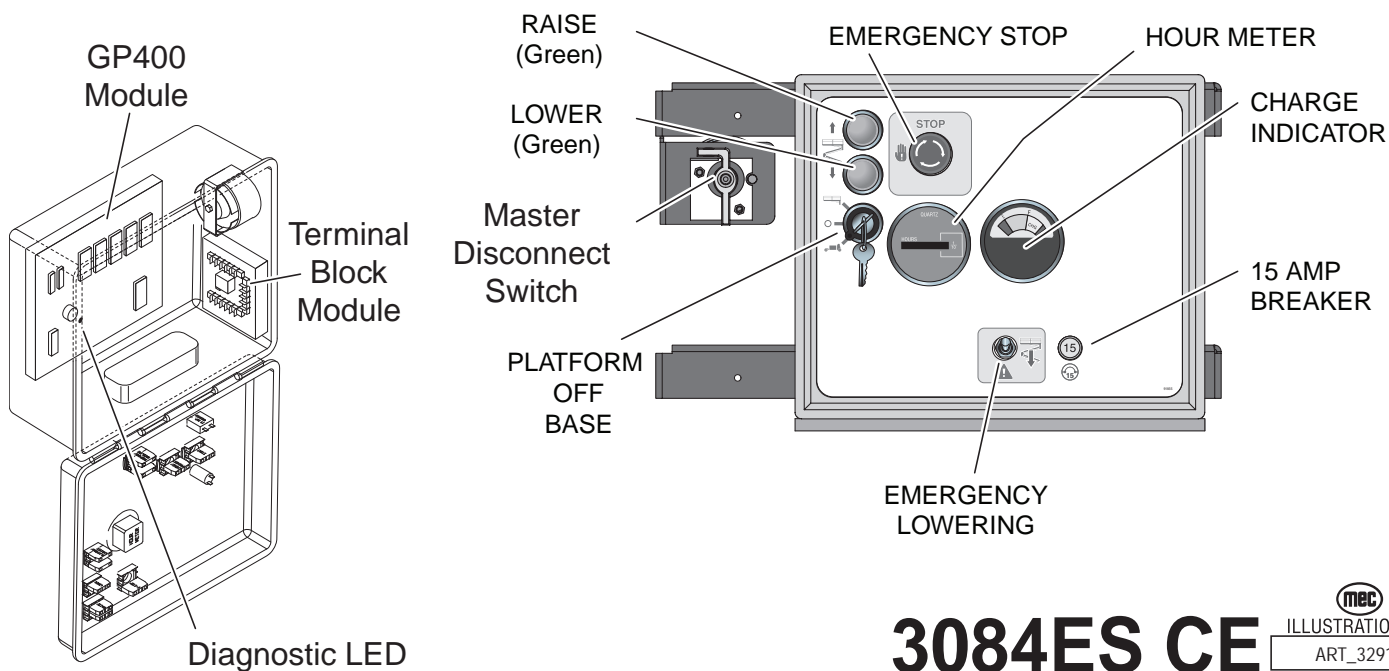
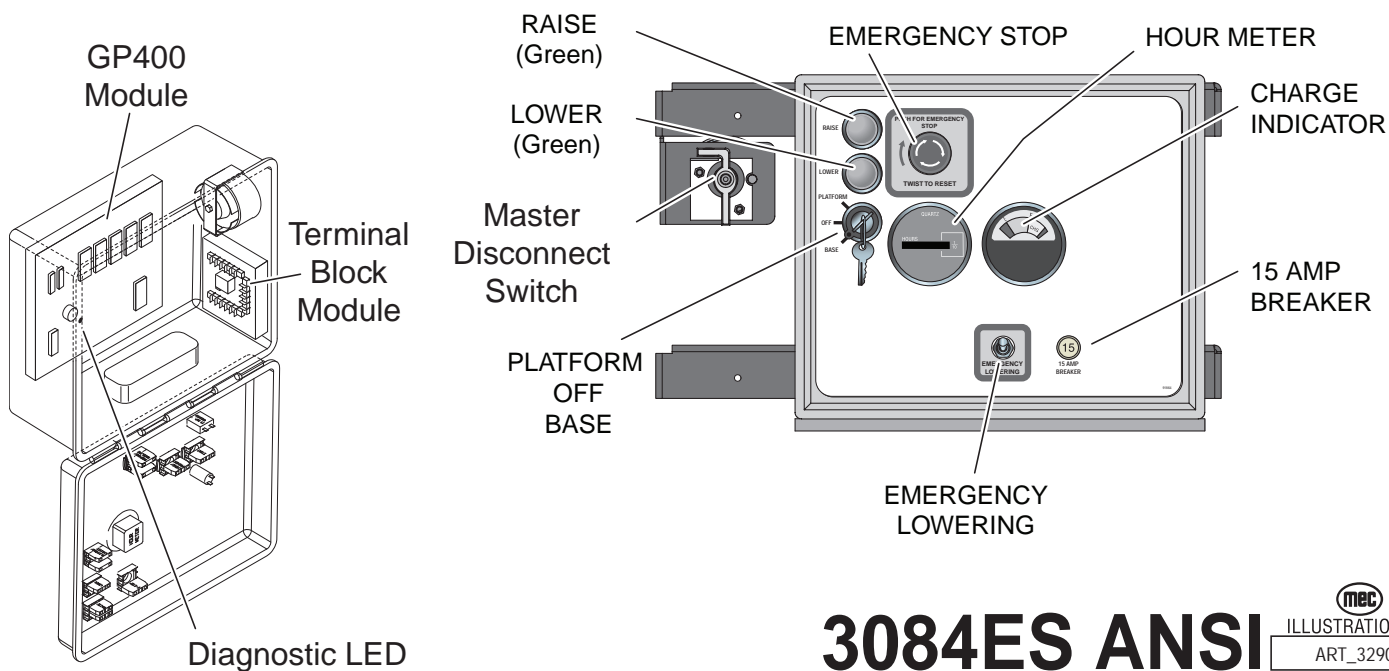

XX84RT Model, Hydraulic Schematic with Hydrastatic Drive

2684RT - From Serial # 12800200

3084RT - From Serial # 11800400

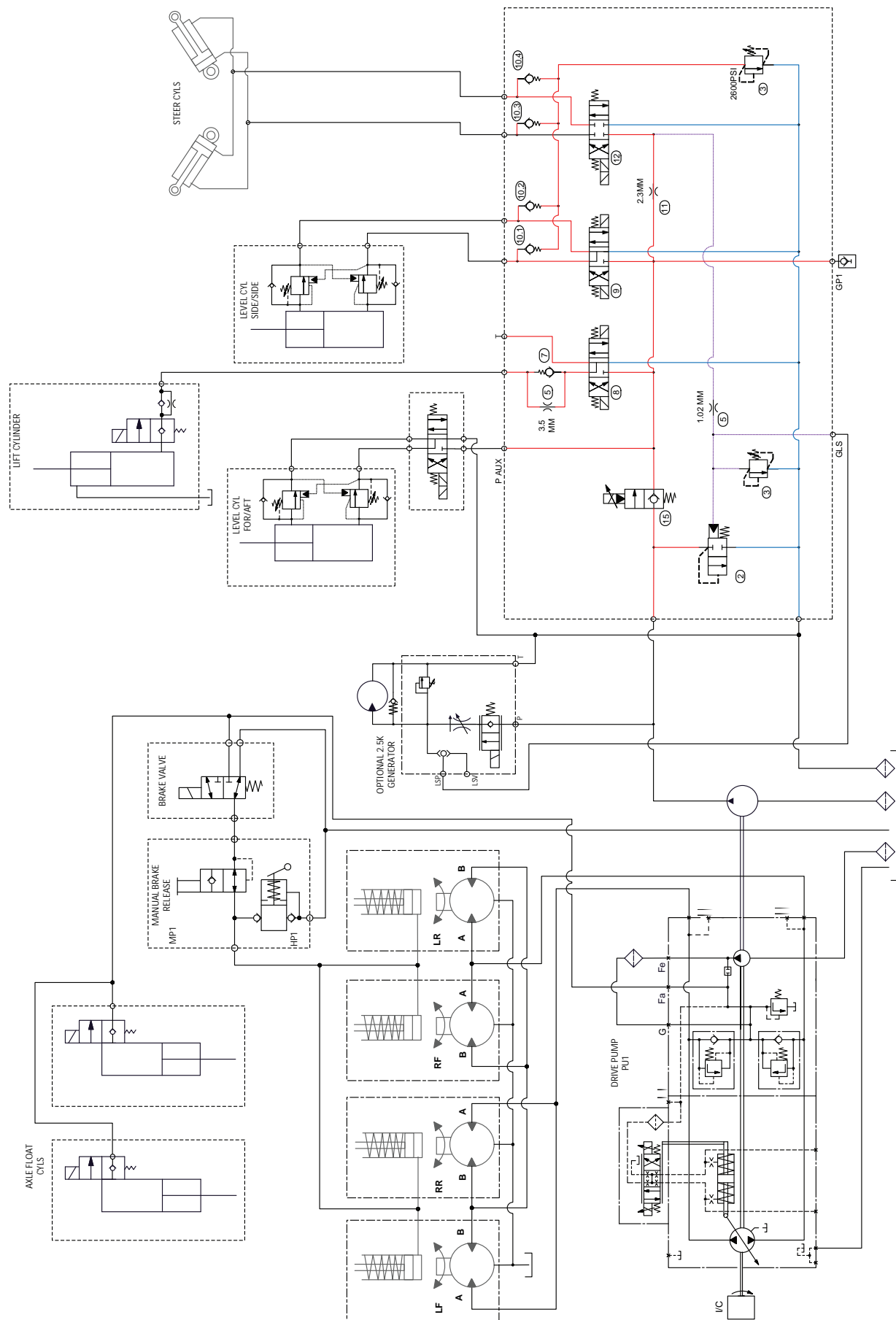

XX84 RT Diesel Models - Electrical Schematic, Part 1

2684 RT - From Serial # 12800200

3084 RT - From Serial # 11800400

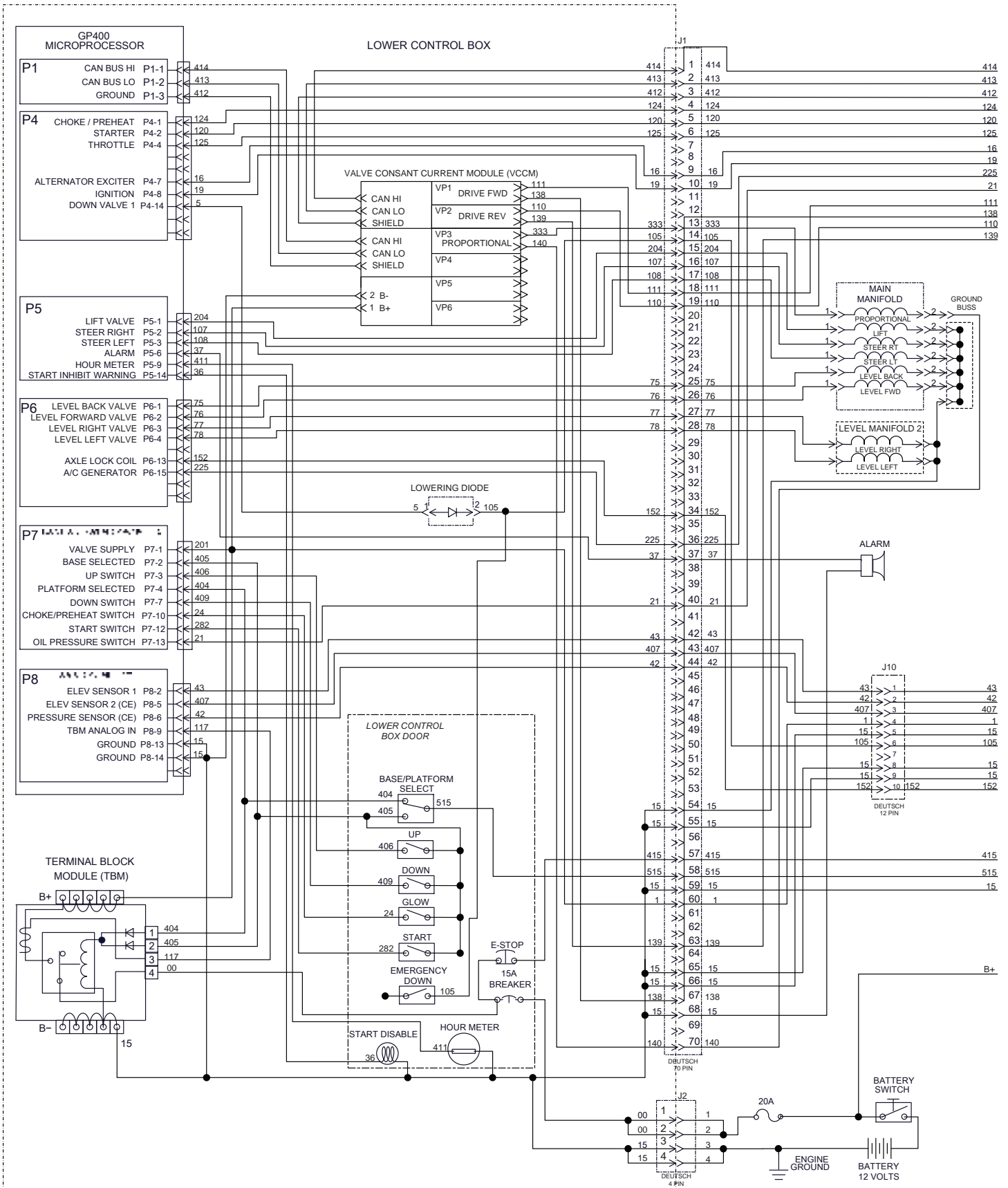

XX84 RT Diesel Models - Electrical Schematic, Part 2

2684 RT - From Serial # 12800200

3084 RT - From Serial # 11800400

