

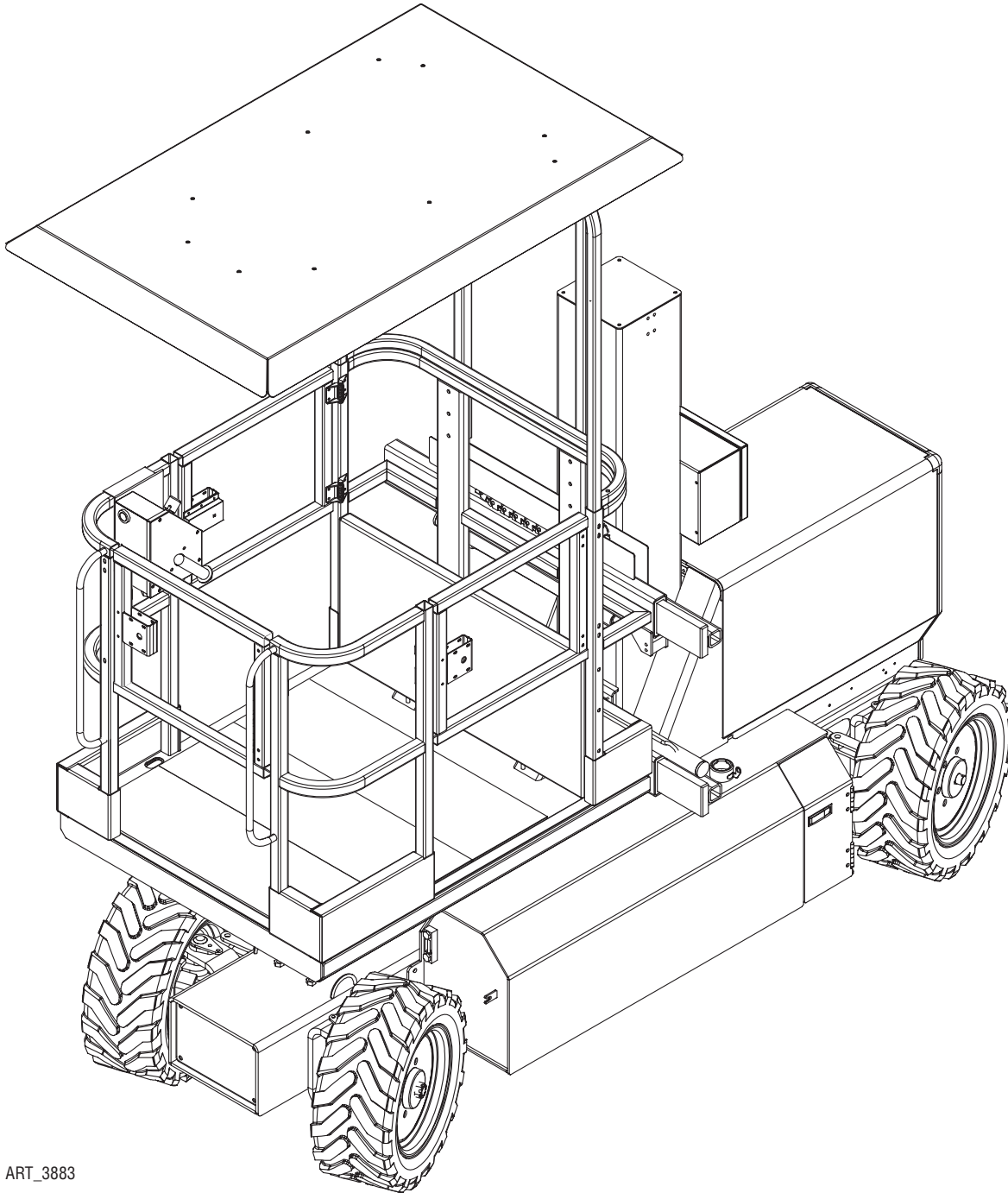

SERVICE AND PARTS MANUAL

IBZ



ART_3883

IBZ

Serial Number Range

1700001 - Up

December 2013

Revision History

Original Release Date: December 2011

Date	Reason for Update
12/2013	New Release



Aerial Platform Sales Corp.

1401 S. Madera Avenue • Kerman, CA 93630 USA
Ph: 1-800-387-4575 • 1-559-842-1500 • FAX 1-559-842-1520
E-mail: info@mecAWP.com • Web: www.mecAWP.com

Service Table of Contents

Introduction I	Page
Machine Specifications	II
MEC Operator Policy	III
Safety Symbols	IV
General Safety Tips	V
Hydraulic System	VI
Electrical System	VI
Total System	VI
Primary Machine Components	VII
Emergency Systems and Procedures	IX
Emergency Lowering	X
Free-Wheel Configuration For Winching or Towing	XI
Lift and Support the Machine	XII

Section 1: Hydraulic System	Page
Hydraulic System – General	1-3
Hydraulic Roadmap	1-4
Hydraulic Fluid	1-5
Handling Precautions	1-5
Fluid Recommendations	1-5
System Flushing Procedure	1-5
Hydraulic Fluid Reservoir	1-6
Hydraulic Filter Assembly	1-6
Hydraulic Pump	1-7
Drive Motor/Brake Units	1-8
Disassembly	1-8
Assembly	1-9
Braking Circuit	1-10
Functions Manifold & Hydraulic Valves	1-11
General Cylinder Repair	1-12
Removal	1-12
Preparation	1-13
Cylinder Disassembly	1-13
Cylinder Assembly	1-14

Section 2: Electrical System	Page
Electrical System – General	2-3
Batteries	2-5
Battery Maintenance (in storage)	2-5
Battery Replacement	2-7
Controls	2-8
Lower Controls	2-8
Upper Controls	2-9
Alarms and Switches	2-10
Deutsch Connectors	2-12
Continuity Checks	2-13



Service Table of Contents

GP400 Control Module Setup	2-16
Location	2-16
General Description	2-17
GP400 Calibration	2-18
Calibration Problems	2-20
Failure Messages	2-20
Information Messages	2-25

Section 3: Mechanical Components

	Page
Mechanical Components	3-2
Base	3-2
Tires and Wheels	3-2
Hoses and Cables	3-3
Drive Motors	3-4
Steer Cylinders	3-7
Platform Side Shift Cylinders	3-9
Platform	3-11
Lift Cylinder and Mast	3-13
Lubrication	3-23
Engine Maintenance	3-24

Section 4: Troubleshooting

	Page
General Troubleshooting Tips	4-3
Electrical System Troubleshooting	4-4
GP400 Module	4-5
Matrix Module	4-6
Terminal Block Module (TBM)	4-6
EZ-Cal Scan Tool	4-7
EZ-Cal Adjustments	4-11
EZ-Cal Setup	4-13
EZ-Cal Diagnostics	4-14
Ez-Cal Retrieve Mode And Help Messages	4-18
MODE Messages	4-18
Troubleshooting Chart	4-28

Section 5: Schematics

Page

INTRODUCTION

This manual consists of Service and Illustrated Parts sections.

The Service Section of this manual is designed to provide you, the customer, with the instructions needed to properly maintain the MEC self-propelled aerial work platform. When used in conjunction with the Illustrated Parts Section and the Operators Manual (provided separately), this manual will assist you in making necessary adjustments and repairs, and identifying and ordering the correct replacement parts.

All parts represented here are manufactured and supplied in accordance with MEC quality standards.

We recommend that you use genuine MEC parts to ensure proper operation and reliable performance.

To obtain maximum benefits from your MEC Aerial Work Platform, always follow the proper operating and maintenance procedures. Only trained authorized personnel should be allowed to operate or service this machine. Service personnel should read and study the Operator's, Service and Parts Manuals in order to gain a thorough understanding of the unit prior to making any repairs.

CONTENTS	PAGE
Machine Specifications	II
MEC Operator Policy	III
Safety Symbols	IV
General Safety Tips	V
Hydraulic System	VI
Electrical System	VI
Total System	VI
Primary Machine Components	VII
Emergency Systems and Procedures	IX
Emergency Lowering	X
Free-Wheel Configuration For Winching or Towing	XI
Lift and Support the Machine	XII

FIGURES	PAGE
Support Platform	V
Component Locations	VII
Emergency Stop Buttons	IX
Emergency Lowering	X



MACHINE SPECIFICATIONS

IBZ			
Working Height*		12.5 ft	4.0 m
Platform Height		6.5 ft	2.0 m
Maximum Drive Height		6.5 ft	2.0 m
Machine Weight** (Unloaded)		4400 lb	1996 kg
Maximum Platform Capacity		600 lb	272 kg
Maximum Occupants		2	
Stowed Height	Including canopy	9 ft 6 in	2.9 m
	Excluding canopy	7 ft 0 in	2.13 m
Overall Length		113 in	2.87 m
Overall Width		48 in	1.22 m
Wheel Base		85 in	2.16 m
Platform Dimensions	Length	53 in	1.35 m
	Platform Width	48 in	1.22m
Turning Radius,	Inside	11 ft	3.35 m
	Outside	16 ft	4.88 m
Ground Clearance		8 in	20 cm
Lift/Lower Speeds		6 sec/6 sec	
Side Shift Speeds		6 sec	
Drive Speed (Proportional)	Stowed	5 mph	8 km/h
	Raised or extended	2.5 mph	4 km/h
Gradeability	Stowed, downhill	40%/21.8°	
	Stowed, uphill	40%/21.8°	
Breakover Angle		39%/ 21.3°	
Maximum Operating Wind Speed		28 mph	12.5 m/sec (45 km/h)
Ground Pressure/Wheel (Maximum)		100 psi	7.0 kg/cm ²
Maximum Wheel Load		1500 lbs	680 kg
Tire Size		23 in. od	.58 m od
Wheel Lug Nut Torque		130 ft/lb	176 Nm
Maximum Hydraulic Pressure	Main System	3200 psi	220 bar
	Lift System	2400 psi	165 bar
Hydraulic Fluid Capacity		32 gal	120 liter
Meets applicable requirements of ANSI A92.6-2006 Section 4			
*Working Height adds 6 feet (2 m) to platform height.			
**Weight may increase with certain options.			
		Engine	Kubota D1105E, 24.8 HP (18.5 kW) Tier 4 Compliant Liquid-Cooled Diesel
		Fuel Type	Diesel
		Fuel Capacity	40 gal 150 liter
		Alternator	120 amp
		Battery	One 1000 CCA 12V Type 31
		Noise Level	86 dB @ 1m
		Control System	12V DC
		Brakes	4 wheel multi disc

MEC OPERATOR POLICY

NOTE: The best method to protect yourself and others from injury or death is to use common sense. If you are unsure of any operation, don't start until you are satisfied that it is safe to proceed and have discussed the situation with your supervisor.

Service personnel and machine operators must understand and comply with all warnings and instructional decals on the body of the machine, at the ground controls, and platform control console.



MODIFICATIONS OF THIS MACHINE FROM THE ORIGINAL DESIGN AND SPECIFICATIONS WITHOUT WRITTEN PERMISSION FROM MEC ARE STRICTLY FORBIDDEN. A MODIFICATION MAY COMPROMISE THE SAFETY OF THE MACHINE, SUBJECTING OPERATOR(S) TO SERIOUS INJURY OR DEATH.

MEC's policies and procedures demonstrate our commitment to Quality and our relentless ongoing efforts towards Continuous Improvement, due to which product specifications are subject to change without notice.

Any procedures not found within this manual must be evaluated by the individual to assure oneself that they are "proper and safe."

Your MEC Aerial Work Platform has been designed, built, and tested to provide many years of safe, dependable service. Only trained, authorized personnel should be allowed to operate or service the machine.

MEC, as manufacturer, has no direct control over machine application and operation. Proper safety practices are the responsibility of the user and all operating personnel.

If there is a question on application and/or operation contact:



MEC Aerial Work Platform

1401 S. Madera Avenue
Kerman, CA 93630 USA
Ph: 1-800-387-4575
www.mecAWP.com

SAFETY SYMBOLS

To help you recognize important safety information, we have identified warnings and instructions that directly impact on safety with the following signals:



“DANGER” INDICATES AN IMMINENTLY HAZARDOUS SITUATION WHICH, IF NOT AVOIDED, WILL RESULT IN DEATH OR SERIOUS INJURY. THIS SIGNAL WORD IS LIMITED TO THE MOST EXTREME SITUATIONS.



“WARNING” INDICATES A POTENTIALLY HAZARDOUS SITUATION WHICH, IF NOT AVOIDED, COULD RESULT IN DEATH OR SERIOUS INJURY.



“CAUTION” indicates a potentially hazardous situation which, if not avoided, may result in minor or moderate injury. It may also be used to alert against unsafe practices.



“Caution” without alert symbol indicates a situation which, if not avoided, may result in property damage.

GENERAL SAFETY TIPS

Regular inspection and conscientious maintenance is the key to efficient economical operation of your aerial work platform. It will help to assure that your equipment will perform satisfactorily with a minimum of service and repair.

The actual operating environment of the machine governs the inspection schedule. Correct lubrication is an essential part of the preventative maintenance to minimize wear on working parts and ensure against premature failure. By maintaining correct lubrication, the possibility of mechanical failure and resulting downtime is reduced to a minimum.

- Never leave hydraulic components or hoses open. They must be protected from contamination (including rain) at all times.
- Never open a hydraulic system when there are contaminants in the air.
- Always clean the surrounding area before opening hydraulic systems.
- Use only recommended lubricants. Improper lubricants or incompatible lubricants may be as harmful as no lubrication.
- Watch for makeshift “fixes” which can jeopardize safety as well as lead to more costly repair.

HYDRAULIC SYSTEM



**HYDRAULIC FLUID UNDER PRESSURE CAN PENETRATE AND BURN SKIN, DAMAGE EYES, AND MAY CAUSE SERIOUS INJURY, BLINDNESS, AND EVEN DEATH.
CORRECT LEAKS IMMEDIATELY.**



Hydraulic fluid leaks under pressure may not always be visible. Check for pin hole leaks with a piece of cardboard, not your hand.

ELECTRICAL SYSTEM



Prevent damage to battery and/or electrical system;

- **Always disconnect the negative battery cable first.**
- **Always connect the positive battery cable first.**

When the negative cable is installed, a spark will occur if contact is made between the positive side of the battery and a metal surface on the machine. This can cause damage to the electrical system, battery explosion, and personal injury.

TOTAL SYSTEM



ENGINE COOLANT LEVEL MUST BE CHECKED ONLY AFTER ENGINE HAS COOLED. IF RADIATOR CAP IS REMOVED WHILE THE COOLANT IS AT NORMAL OPERATING TEMPERATURE, PRESSURE WITHIN THE COOLANT SYSTEM WILL FORCE HOT LIQUID OUT THROUGH THE FILLER OPENING AND MAY CAUSE SEVERE SCALDING.

FAILURE TO PERFORM PREVENTIVE MAINTENANCE AT RECOMMENDED INTERVALS MAY RESULT IN THE UNIT BEING OPERATED WITH A DEFECT THAT COULD RESULT IN INJURY OR DEATH OF THE OPERATOR.

IMMEDIATELY REPORT TO YOUR SUPERVISOR ANY DEFECT OR MALFUNCTION. ANY DEFECT SHALL BE REPAIRED PRIOR TO CONTINUED USE OF THE AERIAL WORK PLATFORM.

INSPECTION AND MAINTENANCE SHOULD BE PERFORMED BY QUALIFIED PERSONNEL FAMILIAR WITH THE EQUIPMENT.

SUPPORTING THE ELEVATING ASSEMBLY



DEATH OR SERIOUS INJURY HAZARD!
NEVER PERFORM WORK OR INSPECTION ON THE MACHINE WITH THE PLATFORM ELEVATED WITHOUT FIRST SUPPORTING THE ELEVATING ASSEMBLY USING THE MAINTENANCE PROP.



DO NOT lower the platform with the Maintenance Prop in contact with the chassis cover.

The elevating assembly must be supported before working on or inspecting the machine with the platform elevated.

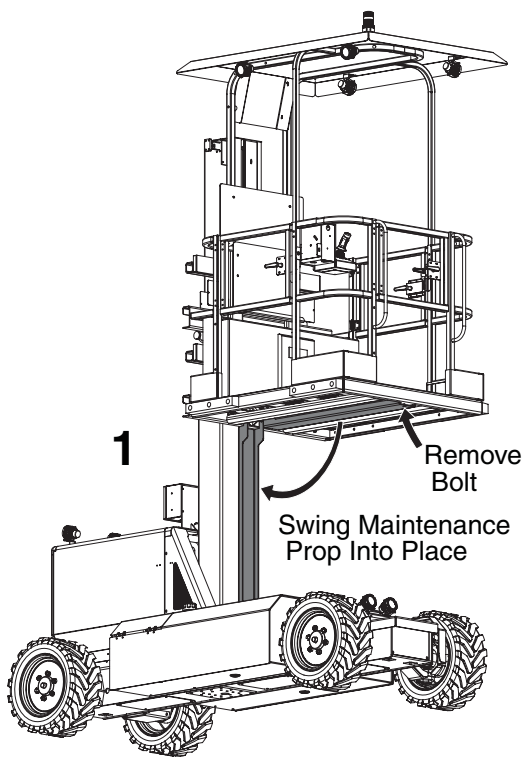

ART_4240

Use the Side Shift function to center the platform, then raise the platform to approximately 6 ft. Remove the bolt holding the Maintenance Prop into place and allow it to swing down until it touches the mast (1).

Carefully lower the platform, ensuring that (2) the end of the Maintenance Prop drops behind the chassis cover. Continue to lower until (3) the Maintenance Prop comes to rest at the base of the mast behind the mast mounting bolts.

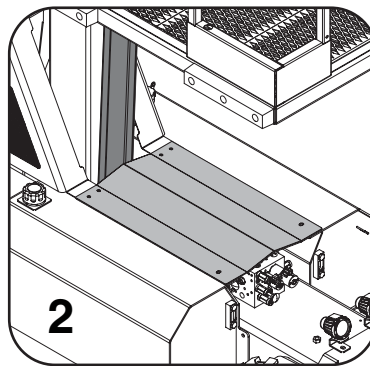

ART_4241

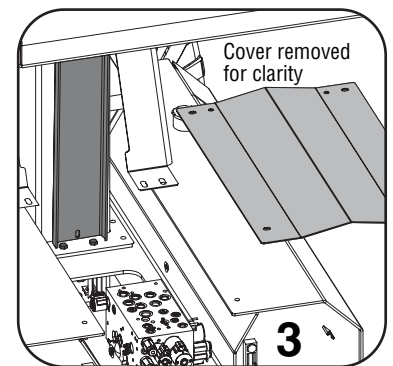







To stow the Maintenance Prop, raise the platform until the prop clears the chassis cover. Swing the Maintenance Prop back to the stowed position and replace the bolt that holds it in place.

TORQUE SPECIFICATIONS

FASTENERS

Use the following values to apply torque unless a specific torque value is called out for the part being used.

AMERICAN STANDARD CAP SCREWS								METRIC CAP SCREWS									
SAE GRADE	5				8				METRIC GRADE	8.8				10.9			
CAP SCREW SIZE - inches -									CAP SCREW SIZE - millimeters -	 				 			
	TORQUE				TORQUE					TORQUE				TORQUE			
	FT. LBS		Nm		FT. LBS		Nm			FT. LBS		Nm		FT. LBS		Nm	
	MIN	MAX	MIN	MAX	MIN	MAX	MIN	MAX	MIN	MAX	MIN	MAX	MIN	MAX	MIN	MAX	
1/4 - 20	6.25	7.25	8.5	10	8.25	9.5	11	13	M6 X 1.00	6	8	8	11	9	11	12	15
1/4 - 28	8	9	11	12	10.5	12	14	16	M8 X 1.25	16	20	21.5	27	23	27	31	36.5
5/16 - 18	14	15	19	20	18.5	20	25	27	M10 X 1.50	29	35	39	47	42	52	57	70
5/16 - 24	17.5	19	23	26	23	25	31	34	M12 X 1.75	52	62	70	84	75	91	102	123
3/8 - 16	26	28	35	38	35	37	47.5	50	M14 X 2.00	85	103	115	139	120	146	163	198
3/8 - 24	31	34	42	46	41	45	55.5	61	M16 X 2.50	130	158	176	214	176	216	238	293
7/16 - 14	41	45	55.5	61	55	60	74.5	81	M18 X 2.50	172	210	233	284	240	294	325	398
7/16 - 20	51	55	69	74.5	68	75	92	102	M20 X 2.50	247	301	335	408	343	426	465	577
1/2 - 13	65	72	88	97.5	86	96	116	130	M22 X 2.50	332	404	450	547	472	576	639	780
1/2 - 20	76	84	103	114	102	112	138	152	M24 X 3.00	423	517	573	700	599	732	812	992
9/16 - 12	95	105	129	142	127	140	172	190	M27 X 3.00	637	779	863	1055	898	1098	1217	1488
9/16 - 18	111	123	150	167	148	164	200	222	M3 X 3.00	872	1066	1181	1444	1224	1496	1658	2027
5/8 - 11	126	139	171	188	168	185	228	251									
5/8 - 18	152	168	206	228	203	224	275	304									
3/4 - 10	238	262	322	255	318	350	431	474									
3/4 - 16	274	302	371	409	365	402	495	544									
7/8 - 9	350	386	474	523	466	515	631	698									
7/8 - 14	407	448	551	607	543	597	736	809									
1 - 8	537	592	728	802	716	790	970	1070									
1 - 14	670	740	908	1003	894	987	1211	1137									

Torque values apply to fasteners as received from the supplier, dry or when lubricated with normal engine oil.
If special graphite grease, molydisulphide grease, or other extreme pressure lubricants are used, these torque values *do not apply*.

HYDRAULIC COMPONENTS TORQUE TABLE

NOTE: Always lubricate threads with clean hydraulic fluid prior to installation.

Use the following values to torque hydraulic components when a specific value is not available. Always check for torque values in the following places before relying on the Hydraulic Components Torque Table:

- parts drawings and service instructions in this manual.
- packaging and instruction sheets provided with new parts.
- instruction manuals provided by the manufacturer of the component being serviced.

TYPE: SAE PORT SERIES	CARTRIDGE POPPET		FITTINGS		HOSES	
	FT. LBS	Nm	FT. LBS	Nm	FT. LBS	Nm
#4	N/A	N/A	N/A	N/A	135 - 145	15 - 16
#6	N/A	N/A	10 - 20	14 - 27	215 - 245	24 - 28
#8	25 - 30	31 - 41	25 - 30	34 - 41	430 - 470	49 - 53
#10	35 - 40	47 - 54	35 - 40	47 - 54	680 - 750	77 - 85
#12	85 - 90	115 - 122	85 - 90	115 - 122	950 - 1050	107 - 119
#16	130 - 140	176 - 190	130 - 140	176 - 190	1300 - 1368	147 - 155

EMERGENCY SYSTEMS AND PROCEDURES



IF THE CONTROL SYSTEM FAILS WHILE THE PLATFORM IS ELEVATED, HAVE AN EXPERIENCED OPERATOR USE THE EMERGENCY LOWERING PROCEDURE TO SAFELY LOWER THE PLATFORM.

DO NOT ATTEMPT TO CLIMB DOWN ELEVATING ASSEMBLY.

EMERGENCY STOP

The machine is equipped with an EMERGENCY STOP switch at the base controls and at both platform control boxes.

- Press the EMERGENCY STOP switch at any time to stop all machine functions.
- Turn switch *clockwise* to reset.

SELECTOR SWITCH SET TO PLATFORM

- Either switch will stop all machine functions.
- Both switches must be reset or machine will not operate.

SELECTOR SWITCH IS SET TO BASE

- The upper controls are locked out.
- The lower controls switch must be reset or the machine will not operate.
- The machine will operate from the lower controls if the upper controls switch is tripped.

Figure 1-1: Emergency Stop Buttons



ART_3817



ART_3866

EMERGENCY LOWERING

Figure 1-2: Emergency Lowering



**OVERHEAD CRUSH HAZARD!
BE AWARE OF PLATFORM
POSITION WHEN LOWERING
THE PLATFORM.**



**IF THE CONTROL SYSTEM
FAILS WHILE THE PLATFORM
IS ELEVATED, USE THE
EMERGENCY LOWERING
PROCEDURE TO SAFELY
LOWER THE PLATFORM.
DO NOT CLIMB DOWN THE
ELEVATING ASSEMBLY OR
EXIT THE PLATFORM.**

The Emergency Lowering System is used to lower the platform in case of power failure.

To lower the platform, pull the Emergency Lowering Handle, located at the front of the fuel tank.

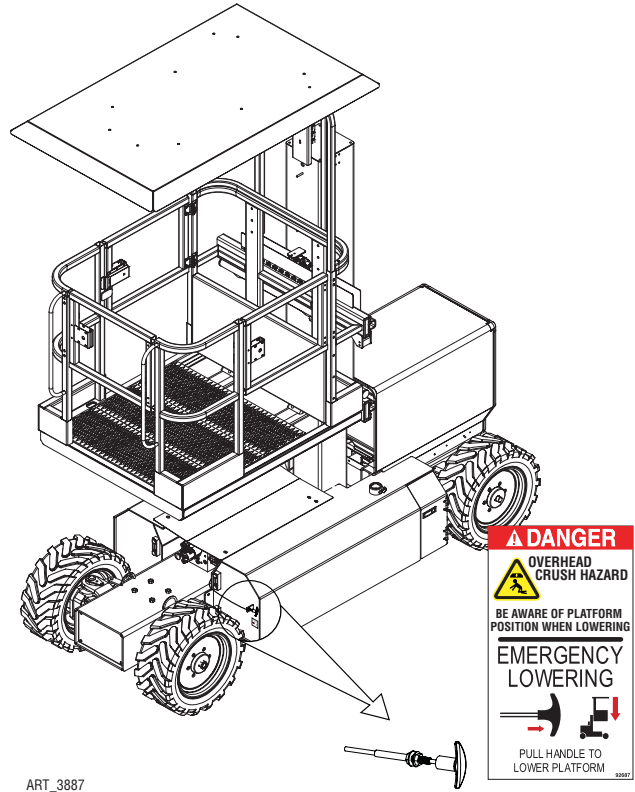

FREE-WHEEL CONFIGURATION FOR WINCHING OR TOWING



RUNAWAY HAZARD!

AFTER RELEASING THE BRAKES THERE IS NOTHING TO STOP MACHINE TRAVEL. MACHINE WILL ROLL FREELY ON SLOPES.

ALWAYS CHOCK THE WHEELS BEFORE MANUALLY RELEASING THE BRAKES.

The machine can be winched or towed short distances at speeds not to exceed 5 MPH (8 km/h). Before towing or winching the machine, it is necessary to release the brakes. Reset the brakes after towing or winching.

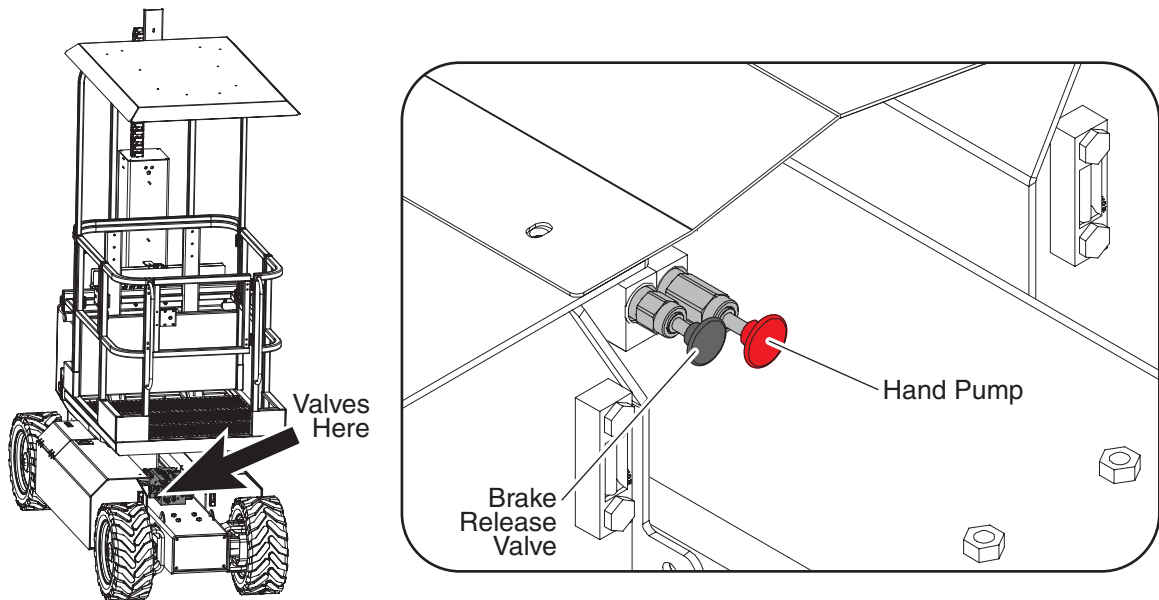

ART_4242

DISENGAGE BRAKES BEFORE TOWING OR WINCHING

- Chock the wheels.
- Push the knurled Brake Release Valve slightly, then turn the valve 180° counter-clockwise and pull it out.
- Press the Hand Pump button on the Functions Manifold repeatedly until the brakes release.

ENGAGE BRAKES BEFORE DRIVING

The brakes must be manually re-engaged.

Push the knurled Brake Release Valve inward, rotate the valve 180° clockwise, then pull out slightly. The valve should not turn when re-engaged.

Be sure that the Brake Release Valve is locked in the inward position before operation.



BE SURE THAT THE BRAKES ARE ENGAGED BEFORE REMOVING THE WHEEL CHOCKS.

BRAKES WILL NOT PROPERLY ENGAGE DURING OPERATION IF THE BRAKE RELEASE VALVE IS NOT LOCKED IN THE INWARD POSITION.

LIFT AND SUPPORT THE MACHINE



DEATH OR SERIOUS PERSONAL INJURY MAY RESULT FROM THE USE OF SUBSTANDARD LIFTING DEVICES AND/OR JACK STANDS. ENSURE THAT ALL LIFTING DEVICES AND JACK STANDS ARE OF ADEQUATE CAPACITY AND IN GOOD WORKING CONDITION BEFORE USE.

The following are needed to safely lift and support the machine;

- a jack with a lifting capacity of two (2) tons or more.
- jack stands with a rating of two (2) tons or more.

TO RAISE THE MACHINE

1. Move machine to a firm level surface capable of supporting the weight of the machine.
2. Chock tires on one end of machine and raise the other end of machine.
3. If wheel is to be removed, break loose but **do not remove** lug nuts before raising the machine.
4. Position a jack at the end of the machine to be lifted, under a solid lifting point in the center of the frame.
5. Raise the machine and place two (2) suitable jack stands under solid support points at the outer ends of the frame.
6. Lower the machine to rest on the jack stands and inspect for stability.

TO LOWER THE MACHINE

1. Tighten lugs to proper torque (refer to machine specifications).
2. Raise machine slightly and remove jack stands.
3. Lower the machine and remove the jack.
4. Remove chocks.



Section 1

HYDRAULIC SYSTEM

CONTENTS	PAGE
Hydraulic System – General	1-3
Hydraulic Roadmap	1-4
Hydraulic Fluid	1-5
Handling Precautions	1-5
Fluid Recommendations	1-5
System Flushing Procedure	1-5
Hydraulic Fluid Reservoir	1-6
Hydraulic Filter Assembly	1-6
Hydraulic Pump	1-7
Drive Motor/Brake Units	1-8
Disassembly	1-8
Assembly	1-9
Braking Circuit	1-10
Functions Manifold & Hydraulic Valves	1-11
General Cylinder Repair	1-12
Removal	1-12
Preparation	1-13
Cylinder Disassembly	1-13
Cylinder Assembly	1-14

FIGURES**PAGE**

Hydraulic System	1-3
Hydraulic Fluid Reservoir	1-6
Hydraulic Filter	1-6
Wheel Motor Assembly	1-8
Manifold/Drive Link Assembly	1-9
Typical Cylinders, Exploded View	1-12

HYDRAULIC SYSTEM – GENERAL

The hydraulic integrated circuit, generally known as the manifold system (valve type) is designed to control all or part of machine functions by integrating various hydraulic cartridge valves into a manifold to provide directional, pressure, flow, and load control.

The hydraulic system is a feedback, load-sensing type. Generally in this type of system, hydraulic fluid is provided by a variable displacement, pressure compensated, axial piston type pump which is directly coupled to the engine. As the engine turns, the hydraulic pump drains fluid from the reservoir and pumps this fluid to the Functions Manifold.

If no function is in use, the pump remains on standby and no fluid is pumped to the manifold. Each function has a maximum pressure control limit set by pressure relief valve.

Figure 1-1: Hydraulic System

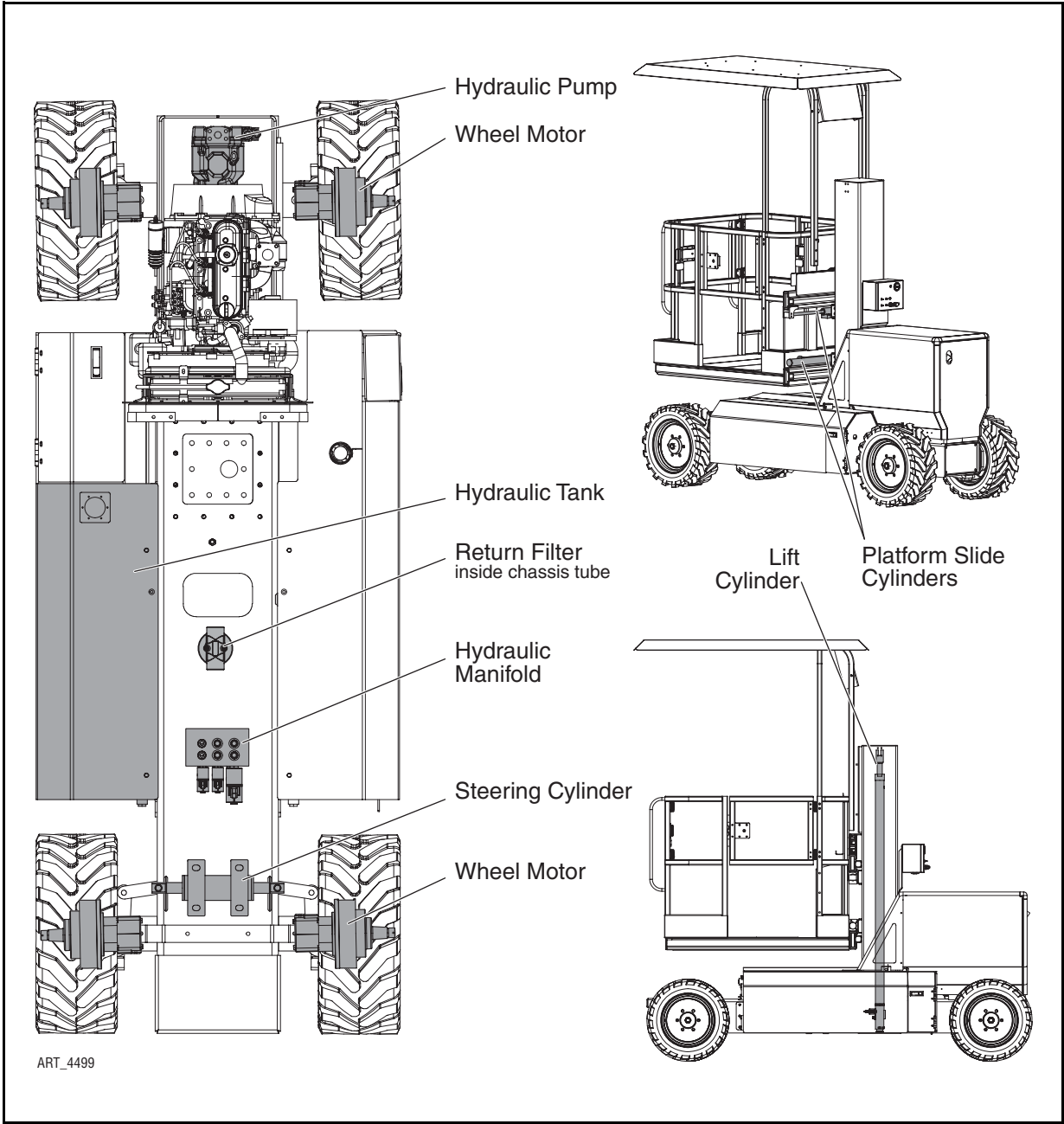

HYDRAULIC ROADMAP

HYDRAULIC RESERVOIR

Hydraulic fluid is held in the reservoir for delivery to the various components and then returned to the reservoir. Returning hydraulic fluid is routed through a filter before entering the reservoir. The reservoir also serves as the oil cooling device.

PUMP

The pump delivers hydraulic fluid under pressure to the Functions Manifold.

FUNCTIONS MANIFOLD

The Functions Manifold directs the hydraulic fluid to the hydraulically operated components and returns fluid to the reservoir through the use of electronically operated solenoid valves.

DRIVE AND BRAKE SYSTEM

There are four (4) hydraulic, fixed-displacement gear wheel motors that provide power to all four wheels.

All wheel motors have integral spring-held brakes. The brakes are released by hydraulic pressure developed in the drive circuit when the drive functions is in use. A fixed orifice in the brake circuit controls the deceleration rate and initiates a smooth stop.

STEERING SYSTEM

Two (2) hydraulic cylinders control steering.

PLATFORM LIFT SYSTEM

The machine is equipped with one (1) hydraulic lift cylinder.

PLATFORM SLIDE SYSTEM

The machine is equipped with two (2) hydraulic cylinders that actuate the Platform Slide function.

HYDRAULIC FLUID

HANDLING PRECAUTIONS



PERSONS IN REGULAR CONTACT WITH MINERAL-BASED HYDRAULIC FLUID NEED TO BE AWARE OF THE IMPORTANCE OF THOROUGH HYGIENE AND THE PROPER METHODS FOR HANDLING MINERAL OILS, IN ORDER TO AVOID POTENTIAL HAZARDS TO HEALTH.

IF MINERAL-BASED HYDRAULIC FLUID IS SPLASHED INTO THE EYES, IT MUST BE WASHED OUT THOROUGHLY USING ABUNDANT QUANTITIES OF WATER. SEEK MEDICAL ATTENTION IF IRRITATION PERSISTS.

HYDRAULIC FLUID UNDER PRESSURE CAN PENETRATE AND BURN SKIN, DAMAGE EYES, AND MAY CAUSE SERIOUS INJURY OR BLINDNESS.

FLUID LEAKS UNDER PRESSURE MAY NOT ALWAYS BE VISIBLE.

FLUID RECOMMENDATIONS

MEC recommends the use of **Mobile Fluid DTE 10, DTE 13 M or AW32** hydraulic fluid. Do not substitute lower grade fluids as pump damage may result.

SYSTEM FLUSHING PROCEDURE

1. With platform fully down, drain the hydraulic fluid from hydraulic reservoir into a clean, empty container.
2. When the hydraulic reservoir is empty, remove the hoses.
3. Flush the hoses with clean hydraulic fluid.
4. Flush out the reservoir with hoses removed from the hydraulic reservoir.
5. Change the hydraulic fluid filter.
6. Reinstall all hoses removed in the previous steps.
7. Fill hydraulic reservoir with filtered, fresh hydraulic fluid (refer to Lubrication Chart).
8. Loosen output hose fittings at pump to flood with hydraulic fluid. Tighten fittings.
9. Start up the machine. Briefly operate all functions. Two or three lift cycles may be necessary to purge all air from lift cylinder(s).
10. When the above procedures have been completed, fill hydraulic reservoir to full mark on sight gauge.
11. Check all leaks and correct as necessary. Machine is now ready to be placed back in operation.

NOTE: Avoid mixing petroleum and synthetic base fluids. It is not advisable to mix fluids of different brands or types, except as recommended.

HYDRAULIC FLUID RESERVOIR

Consists of the reservoir, a filler cap with breather, a drain plug and a sight gauge.
Check reservoir for signs of leakage weekly.

Figure 1-2: Hydraulic Fluid Reservoir

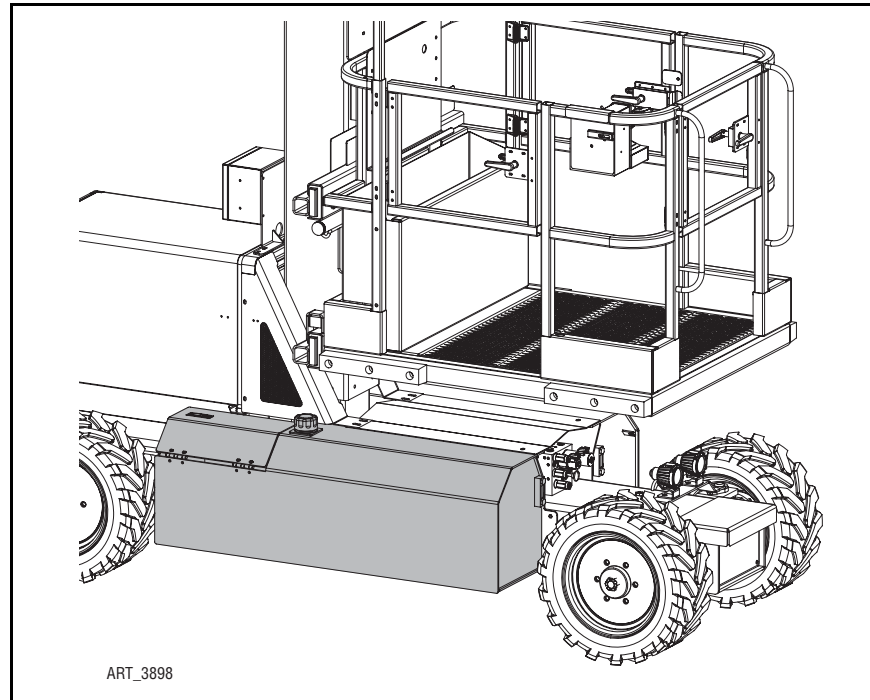

HYDRAULIC FILTER ASSEMBLY



WARNING

BEWARE OF HOT FLUID. CONTACT WITH HOT FLUID MAY CAUSE SEVERE BURNS.

All machines are equipped with a spin-on, bypassing filter. When the filter is clogged, hydraulic flow bypasses the filter element. The filter element must be changed every six months or 500 hours. Extremely dirty conditions may require the filter to be replaced more often.

The filter is accessed from beneath the machine by removing the center Cover Plate.

Figure 1-3: Hydraulic Filter

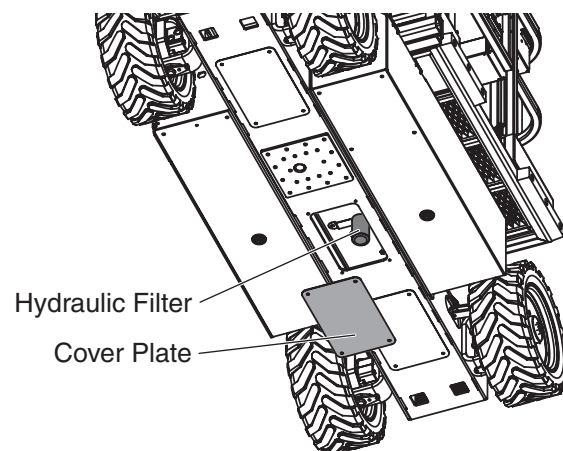

HYDRAULIC PUMP

An internal combustion engine drives a variable displacement axial piston pump.

REMOVE

1. Place a large container under the engine and pump to catch fluid that will be lost during pump replacement. Dispose of used fluid properly.
2. Tag and disconnect hydraulic hoses, and IMMEDIATELY cap or cover the openings to prevent contamination.
3. Remove the two bolts that hold the pump to the housing.
4. Remove the pump.

INSTALL

1. Install drive hub onto pump shaft. Torque bolt to 45 Ft. Lbs. (61 Nm).
2. Position the pump next to the housing. Turn the pump until the splines on the hub align allowing the pump to become flush with the housing.
3. Turn the pump until the bolt holes align with the mounting holes on the housing and install the bolts. Torque to 25-28 Ft. Lbs. (35-38 Nm).
4. Install the hydraulic hoses.
5. Check for leaks and check all hydraulic pressures.

DRIVE MOTOR/BRAKE UNITS

NOTE: Refer to *Section 3* for Remove and Install instructions.
Refer to *Parts Section D*.

There are four fixed-displacement hydraulic gear wheel motors to provide power to the four wheels.

Figure 1-4: Wheel Motor Assembly

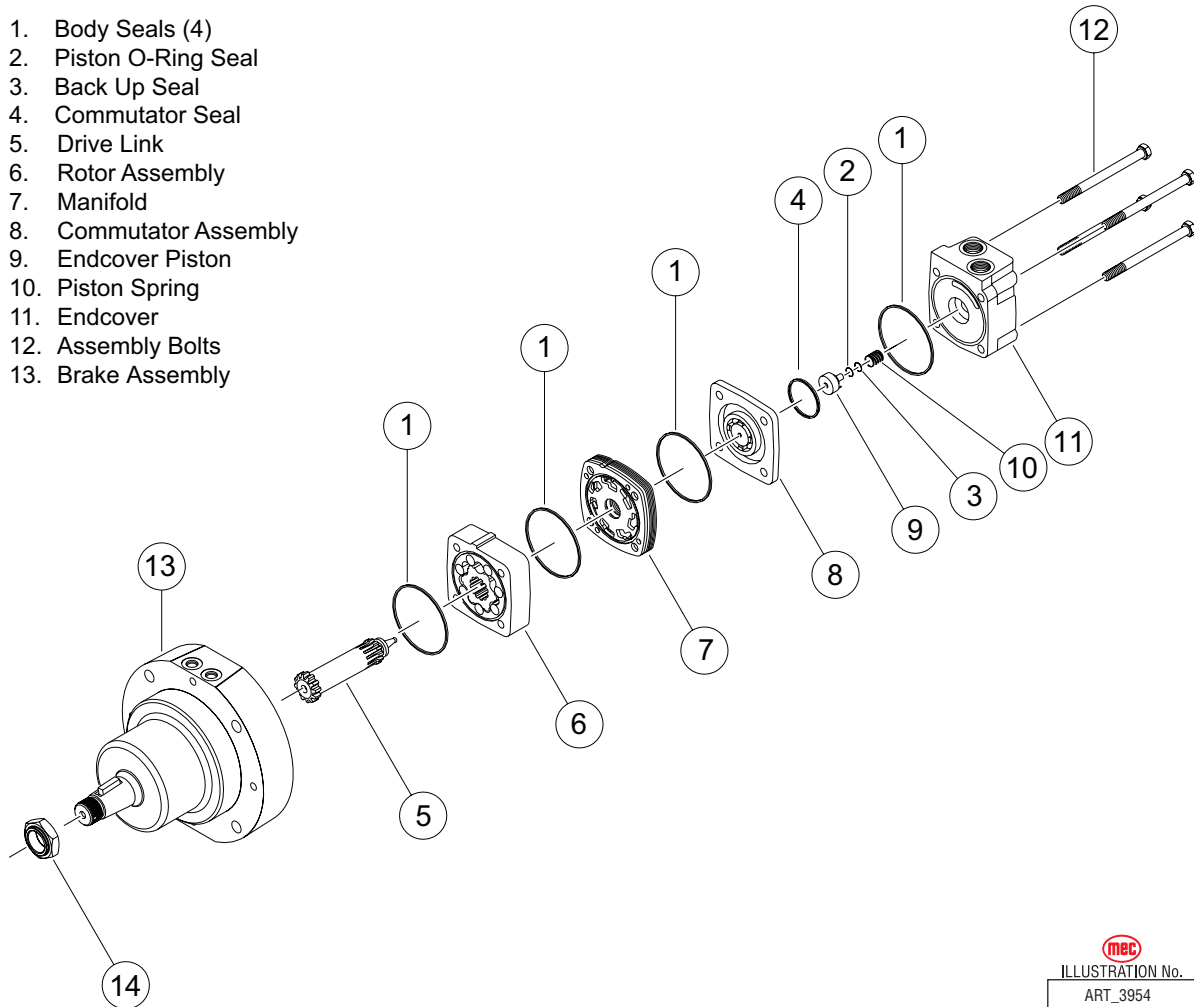

mec
ILLUSTRATION No.
ART_3954

DISASSEMBLY

To aid in reassembly of the motor, make a "V" shaped set of lines from the endcover to the housing using either paint or a marker.

1. With shaft facing down, secure motor in vise by clamping on to brake assembly (13).
 - Loosen and remove four bolts (12) holding motor assembly together. Remove endcover (11) from motor making sure not to drop endcover piston (9).
 - Using needle nose pliers or two small screwdrivers, lift endcover piston (9) out of endcover (11).
 - Remove white Teflon seal (3) and O-ring seal (2) from endcover piston (9) and discard.
 - Remove the piston spring (10) from endcover (11) and lay aside.

2. Lift commutator container and commutator (8) from motor and lay aside.
 - Place commutator on a flat, clean surface with the seal (4) facing up.
 - Place the tip of a small screwdriver on the seal (4) and gently tap until opposite side of seal lifts from groove.
 - Remove seal (4) and discard.
3. Remove manifold (7) and rotor assembly from motor.



Caution - Do not allow rolls to drop from rotor assembly when removing rotor assembly for motor.

- Remove all seals (1) from components and discard.
- Remove drive link (5) from motor and lay aside.

At this point, all parts should be cleaned in an oil-based solvent and dried using compressed air (For safety, observe all OSHA safety guidelines). All new seals should be lightly coated in clean oil prior to installation.

ASSEMBLY

1. Insert the drive link (5) into the shaft with the tapered end facing up.
 - Place a body seal (1) into the groove in the face of the rotor assembly (6).
 - With the seal side of the rotor assembly (6) facing the brake assembly (13), line up the splines of the drive link (5) and the rotor assembly (6) and lower the rotor assembly onto the brake assembly (13) making sure to use the alignment marks as a guide to assure correct orientation of the rotor assembly (and the remaining components).
2. Place a body seal (1) into the groove in each face of the manifold (7).
 - Lift the drive link (5) approximately .100 and place the tip of a small screwdriver under the disk-shaped portion of the drive link to hold it up.
 - Making sure that the notch in the manifold is aligned with the notch in the rotor and that the side with the largest holes faces down.
- Lower the manifold (7) onto the motor and engage the disk shaped portion of the drive link (5) into the groove in the manifold (5) (Figure 1-7).
- Remove the screwdriver and lower the manifold (7).
- If the disk is engaged in the groove, the end of the drive link will protrude above the surface of the manifold. If it doesn't, remove manifold and repeat this step.
3. Using bolts or line up pins align the components assembled thus far.
 - Make sure that components are matching the "V" shape that you drew earlier and that the bolt holes are all aligned.
 - Once everything is aligned make sure that the drive link is still engaged in the manifold. (The motor will not operate if the drive link is not engaged in the manifold).

Figure 1-5: Manifold/Drive Link Assembly

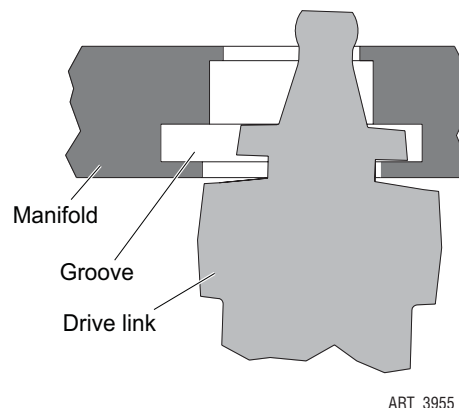

4. Install the commutator seal (4) into the commutator (8) with the metal side facing up.
 - Use finger pressure to press the seal down flush with the surface of the commutator.
 - Place the commutator container (8) onto the manifold (7) and then place the commutator onto the protruding end of the drive link (5) making sure that the seal side faces up.
5. Install the remaining body seal (1) in the groove in the face of the endcover (11).
 - Install the piston spring (10) into the endcover (11), then the white Teflon seal (3), followed by the O-ring seal (2). Lining up the alignment pin, press the piston (9) into the endcover (11).
 - While holding the endcover piston (9) into the endcover (11), lower the endcover assembly onto the motor.
6. Install the four assembly bolts (12) and pre-torque to 10 ft. lbs.
Final torque all bolts to 50 ft. lbs.

BRAKING CIRCUIT

All wheel motors have integral spring-applied hydraulically-released parking brakes. Hydraulic pressure developed in the drive circuit during drive mode releases the brakes. A fixed orifice in the brake circuit controls the brake application after the machine comes to a stop.

The Brake Assembly is not serviceable and should be replaced as a unit.

FUNCTIONS MANIFOLD & HYDRAULIC VALVES

NOTE: Refer to *Parts Section E*.

Tag all components as they are removed to aid in reassembly.

HYDRAULIC MANIFOLD REMOVAL

1. Disconnect the negative battery terminal.
2. Tag and disconnect the solenoid valve leads.
3. Tag and disconnect hydraulic hoses, and **immediately** cap the openings to prevent contamination.
4. Remove the mounting bolts from the manifold.
5. Remove the manifold.

DISASSEMBLY

1. Remove coils from solenoid valves.
2. Mark and remove valves.
3. Mark and remove fittings, plugs, springs, balls, and orifices.

CLEANING AND INSPECTION

1. Wash the manifold in cleaning solvent to remove built-up contaminants, then blow out all passages with clean compressed air.
2. Inspect the manifold for cracks, thread damage and scoring where O-rings seal against internal and external surfaces.
3. Wash and dry each component and check for thread damage, torn or cracked O-rings, and proper operation.
4. Replace defective parts and O-rings.

ASSEMBLY

NOTE: Lubricate all O-rings before installation to prevent damage to the O-ring. Seat balls in manifold block by lightly tapping on the ball with a brass drift punch.

1. Install fittings, plugs, springs, balls, and orifices. Use one drop of Loctite #424 or equivalent thread locker on each screw-in orifice.
2. Install valves.

INSTALLATION

1. Mount the manifold assembly using the mounting bolts.
2. Connect hydraulic hoses (as previously tagged). Be certain to tighten hoses.
3. Connect solenoid leads (as previously tagged).
4. Connect the battery.
5. Operate each hydraulic function and check for proper operation and leaks.
6. Adjust valve pressures.

GENERAL CYLINDER REPAIR



WARNING

CYLINDERS ARE HEAVY. SUPPORT CYLINDERS BEFORE REMOVING HARDWARE THAT SECURES THE CYLINDER TO THE MACHINE.

Figure 1-6: Typical Cylinders, Exploded View

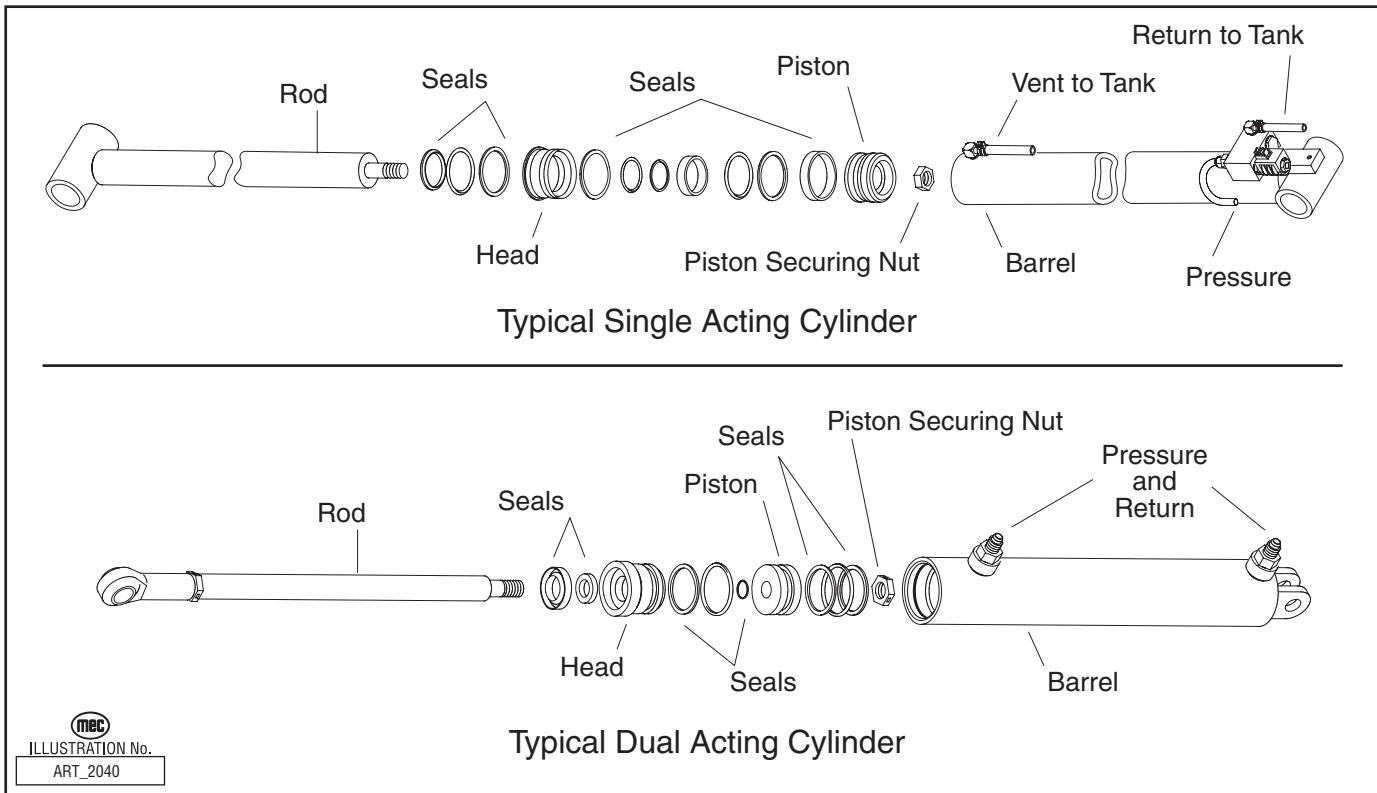

REMOVAL

NOTE: Refer to *Section 3* for Remove and Replace instructions, and the *Parts Manual* for a list of hardware specific to the cylinder being repaired.

1. Tag hoses for proper reassembly.
2. Disconnect hoses and **IMMEDIATELY** cap the openings to prevent contamination.
3. Remove cylinder from the machine as described in *Section 3*.

PREPARATION



Take precautions to protect the rod surface. Guard against dirt or other foreign objects entering system.

1. Drain all fluid from cylinder.
2. Clean all dirt and grit from outside of cylinder.
3. Insert cylinder into vise.

CYLINDER DISASSEMBLY

1. Remove the head from the cylinder body.
2. Remove the shaft assembly from the barrel, pulling in a straight line, so as not to scar the internal parts.
3. Insert shaft into a **soft jawed** vise so that the head and piston can be removed. Be sure the shaft and vise are both clean before using.
4. Remove nut at the end of the shaft and pull head and piston off of the rod.
5. Remove all seals from the head and piston using a non-sharp seal tool. These tools are available from various seal suppliers.
6. Clean all fluid and debris off of the head, piston, shaft, collar and barrel using solvent, rags, and an air hose.
7. Inspect parts for scratches, pits or polishing. Check seal groves and sealing surfaces.
 - a. Scratches or pits deep enough to catch the fingernail are unacceptable; replace the cylinder.
 - b. Polishing is a sign of uneven loading. Check for roundness. If a polished surface is not round within .007 in. (0.18 mm) replace the cylinder.

CYLINDER ASSEMBLY

CAUTION:

- To insure a quality repair, cylinder parts must be thoroughly cleaned, dry, and free of solvents, and assembly must be performed in a clean area free of dust and contamination.
- Do not use sharp edged tools during seal replacement. After installing seals wait at least one hour before assembling the cylinder to allow the seals to return to their original shape.
- Torque all hardware according to the Hydraulic Components Torque Table unless otherwise specified.

1. Lubricate all components with clean hydraulic fluid.
2. Install new seal kit components. Install all seals on the head and piston using the non-sharp seal tool.
3. Place a small amount of fluid on the inside head seals. Reinstall the head on the shaft by slipping head over the piston end of the shaft. Be very careful not to damage the inside seals.
4. Place a small amount of fluid on the inside seals of the piston. Reinstall the piston on the shaft by slowly twisting the piston onto the threads of the shaft. Be very careful not to damage the inside seals.
5. Reinstall the shaft nut. Torque 1 ½" nut to 160 ft. lbs. (216 Nm).
6. Grease the outside seals of the head and piston.
7. Reinstall the shaft into the barrel of the cylinder and push in until groove of the head lines up with the slot in the barrel.
8. Reinstall the cylinder retainer. Installation is reverse of removal.
9. Cycle the cylinder using air to check for proper operation.

NOTE: Keep all parts clean when working with hydraulic cylinders. Even one small piece of dirt or grit can damage the cylinder.



Section 2

ELECTRICAL SYSTEM

CONTENTS	PAGE
Electrical System – General	2-3
Batteries	2-5
Battery Maintenance (in storage)	2-5
Battery Replacement	2-7
Controls	2-8
Lower Controls	2-8
Upper Controls	2-9
Alarms and Switches	2-10
Deutsch Connectors	2-12
Continuity Checks	2-13
GP400 Control Module Setup	2-16
Location	2-16
General Description	2-17
GP400 Calibration	2-18
Calibration Problems	2-20
Failure Messages	2-20
Information Messages	2-25

FIGURES**PAGE**

Emergency Stop Switches	2-3
Diagnostic LED	2-3
Lower Controls	2-8
Upper Controls	2-9
Proximity Sensors	2-10
Relay Locations	2-11
Deutsch Connectors	2-12
Selector Switch	2-13
Toggle Switch, ON-OFF	2-13
Toggle Switch, 1-Pole 2-Position	2-13
Toggle Switch, 1-Pole 3-Position	2-14
Toggle Switch, Momentary	2-14
Button Switch, Momentary	2-15
Emergency Stop Switch	2-15
Relay Operation	2-15
GP400 Module Locations	2-16
EZ-Cal Connection	2-17

TABLES**PAGE**

Table 2-1: Recommended Battery Charge Intervals	2-5
Table 2-2: Battery Specific Gravity and Voltage	2-6

ELECTRICAL SYSTEM – GENERAL

The electrical control system consists of lower controls located on the machine base and upper controls located on the machine platform. Emergency lowering controls are also located on the machine base, and are not electrically operated.

LOWER CONTROLS

The lower controls will operate all functions except the steer and drive functions.

UPPER CONTROLS

The upper controls will operate all functions including drive, steer, lift, and lower. A momentary bi-directional rocker switch on the joystick provides the steering function. The control system for operation of drive, steer, lift, and lower are electric-over-hydraulic type. The drive system is a proportional system controlled by position and direction of the upper controls joystick.

EMERGENCY STOP

There are two red Emergency Stop switches: One located on the upper controls and one on the lower controls. Activation of either Emergency Stop switch will immediately cut electrical power to all controls, thereby stopping all machine functions. Press the switch to stop all electrical power and turn the switch clockwise to reset.

When both Emergency Stop switches are “set”, the controls have electrical power and the machine will operate.

Figure 2-1: Emergency Stop Switches

NOTE: Both switches must be set or the machine will not operate.

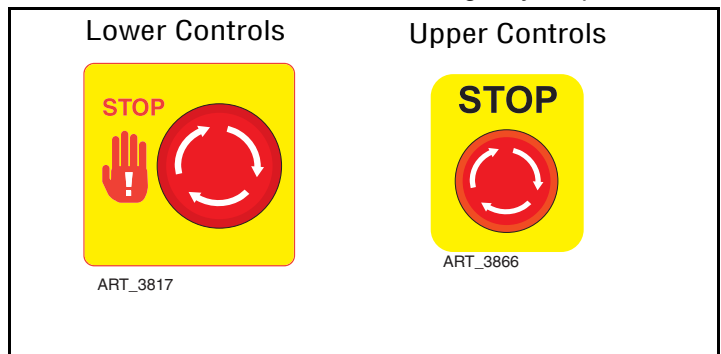
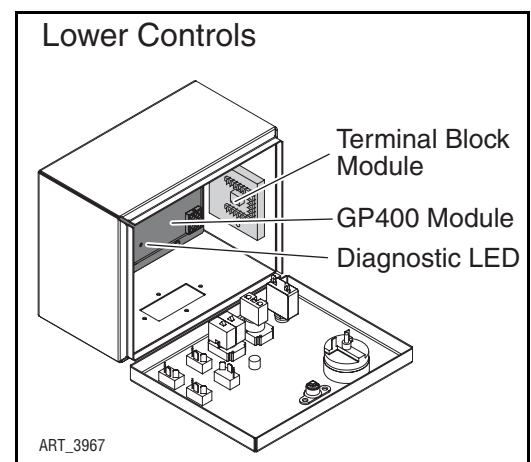

Figure 2-2: Diagnostic LED

DIAGNOSTIC LED

If the machine fails to operate, inspect the GP400 Module located inside the Lower Controls box. The LED located on the module should be *ON*. If the LED is *OFF* or *FLASHING*, refer to *Section 4: Troubleshooting*.



START CIRCUIT CUTOUT INDICATOR LIGHT

The Start Circuit Cutout Indicator light is located on the Lower Controls box (see Figure 2-3 on Page 2-8).

The machine is equipped with a start system protection function, controlled by the GP400. This protects the starter and related parts from damage caused by overcranking in hard starting situations.

- Maximum starter operation time is 10 seconds.
- If no start, the START DELAY light will illuminate and the starter will be disabled for 35 seconds.
- When the START DELAY light goes OFF the starter will operate.

BATTERIES



Discharged batteries can freeze, causing damage to the battery and/or battery case. A broken battery case will allow electrolyte to leak out.



CHARGING BATTERIES CREATE EXPLOSIVE HYDROGEN GAS. KEEP SPARKS, FLAMES AND SMOKING MATERIALS AWAY FROM BATTERIES. ALWAYS WEAR SAFETY GLASSES WHEN WORKING WITH BATTERIES.

BATTERY FLUID IS CORROSIVE. THOROUGHLY RINSE SPILLED FLUID WITH CLEAN WATER.

REPLACE ONLY WITH MANUFACTURER-APPROVED BATTERIES.

BEFORE DISCONNECTING THE BATTERY NEGATIVE (-) LEAD, MAKE SURE THAT ALL SWITCHES ARE OFF. IF ON, A SPARK WILL OCCUR AT THE GROUND TERMINAL THAT COULD IGNITE HYDROGEN GAS OR FUEL VAPORS.

One 12 volt DC battery supplies the electrical power required to start the engine and operate the electrical circuits.

BATTERY MAINTENANCE (IN STORAGE)

Follow these procedures for maintenance of the battery on a machine that is not in use:

- Keep battery clean. Electrolyte of batteries should be checked regularly and kept at proper level.
- Never stack one battery directly on top of another, as post or container damage may occur. If batteries are stored individually, place supporting boards between layers. Rotate stock so that the oldest batteries are used first.
- Batteries should be kept fully charged. A battery, while in storage, should be recharged to full charge at recommended intervals.

A BATTERY FULLY (100%) CHARGED AT 80°F (26.6°C)

- drops to 65% at 32°F (0°C)
- drops to 40% at 0°F (-32°C)

Table 2-1: Recommended Battery Charge Intervals

If Stored At	Recharge
Below 40°F (4°C)	Every week
40°-60°F (4°-15°C)	Every 2 weeks
Above 60°F (15°C)	Every month

BATTERY MAINTENANCE (IN USE)

Check battery and surrounding area for signs of damage or corrosion.

Check battery terminals for:

- **Corrosion:** Regularly clean connections and apply a nonmetallic grease or protective spray to retard corrosion.
- **Loose connections:** Be sure all cable connections are tightly secured, and that good contact is made with terminals.
- **Broken or frayed cables:** Be sure all connections are good and that no loose or broken wires are exposed. Replace as necessary.

Check battery electrolyte level. Replenish the electrolyte, if necessary. Remove vent caps before filling, and USE ONLY DISTILLED WATER. DO NOT OVERFILL. Fill to level indicator (or ½ inch over the top of separators, if there is no level indicator). Fill after charging to prevent overflow of acid due to expansion. Do not use a hose to add water to batteries.

Allowing the electrolyte level to drop below the top of the separators will lead to shortened battery life.

Excessive water usage may indicate that a battery has been overcharged, has been subjected to excessively high temperatures, or is nearing the end of its service life.

BATTERY PREVENTATIVE MAINTENANCE:

15 hours after battery has been charged, spot-check the specific gravity of two or more cells. A fully charged battery should indicate 1.28 specific gravity. If low readings are noted, check the following:

- Check terminals for corrosion, loose connections and broken or frayed cables.
- Check all cells with a hydrometer for variance in specific gravity. A variation of 0.03 points or more between cells is a cause for concern. Mark the low cells.

Recheck specific gravity of all cells after recharging. Wash the top of the battery, making sure all vents are in place. Do not allow cleaning water or other foreign matter to enter the cells. Use a solution of bicarbonate soda (5 tsp. of baking soda per quart of warm water) and water to wash the battery if there is an accumulation of acid.

Table 2-2: Battery Specific Gravity and Voltage

	Specific Gravity		Volts DC	
	Each Cell	Per Cell	12V Battery	
Fully Charged	1.280	2.10	12.60	
Fully Discharged	1.130	1.75	10.50	

BATTERY REPLACEMENT

CAUTION

To prevent damage to the battery and/or electrical system:

- Always disconnect the negative battery cable first.
- Always connect the positive battery cable first.

TO REMOVE A BATTERY;

1. Disconnect the negative battery cable, then the positive battery cable. Remove the battery hold-down hardware.
2. Lift the battery from the compartment, put the battery aside and dispose of properly.

TO INSTALL A BATTERY;

1. Position the battery in the compartment and secure with hold-down hardware.
2. Connect the positive battery cable, then the negative battery cable.

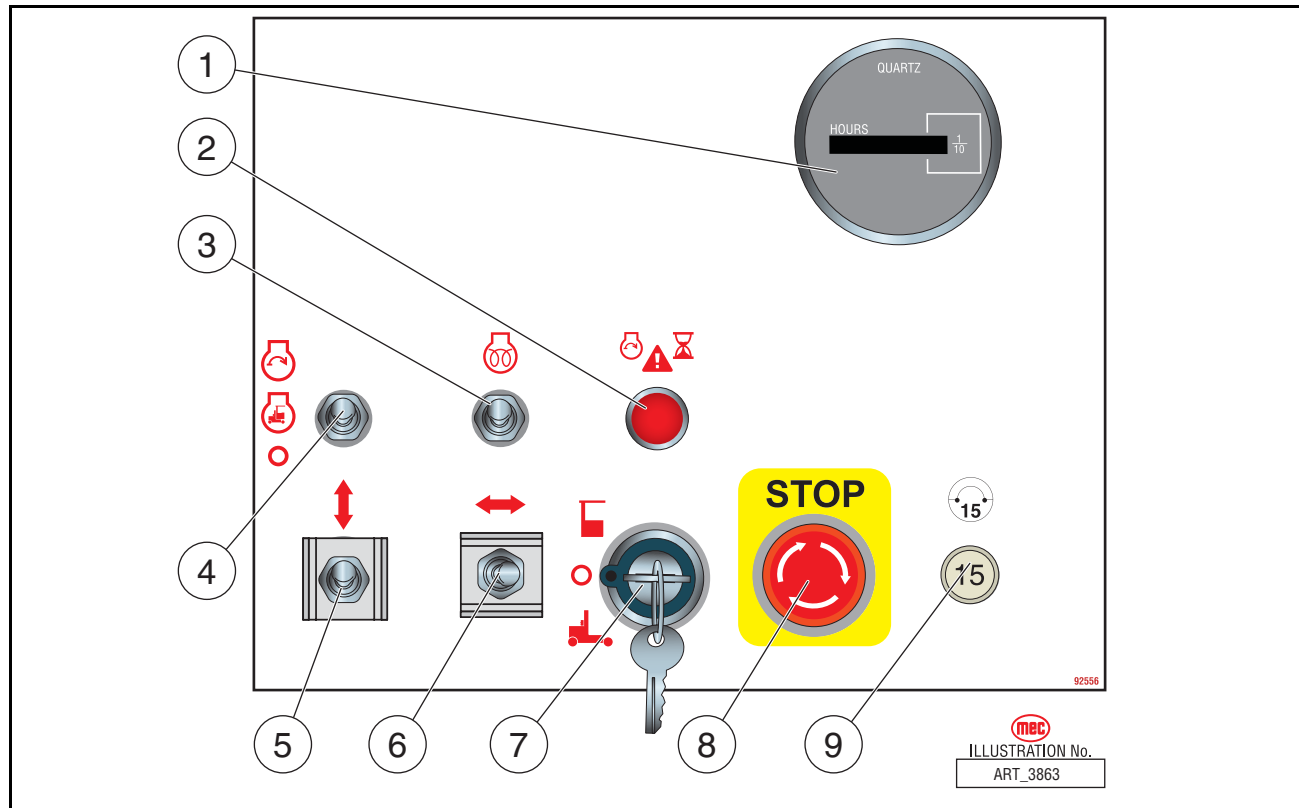
CONTROLS**LOWER CONTROLS****Figure 2-3:** Lower Controls

CONTROL		DESCRIPTION	
1	Hour Meter	Indicates total elapsed time of machine operation.	
2	Starter Circuit Cutout indicator	To protect the starter motor, power will cut off to the starter circuit when the starter motor has run continuously for 15 seconds without starting the engine. The Starter Circuit Cutout indicator light will turn on at the Base Control panel and power to the starter circuit will cut out for 30 seconds.	
3	Glow Switch	Press this switch UP to activate glow plugs prior to starting	
4	Start/Stop Switch	Push Switch UP to start the engine. Push switch DOWN to stop the engine.	
5	Lift/Lower Switch	With the Selector Switch in the BASE position, move this switch up to lift the platform or down to lower the platform.	
6	Side Shift Switch	Move this switch LEFT to move the platform left. Move this switch RIGHT move the platform right.	
7	Selector Switch	Top	PLATFORM: Select to operate from the platform control panel.
		Middle	OFF: Select to stop operation from either control panel.
		Bottom	BASE: Select to operate from the base control panel.
8	Emergency Stop Switch	Press the EMERGENCY STOP switch at any time to stop all machine functions. Turn switch <i>clockwise</i> to reset	
9	Circuit Breaker	Trips when there is excessive electrical load. Push to reset.	

UPPER CONTROLS

Figure 2-4: Upper Controls

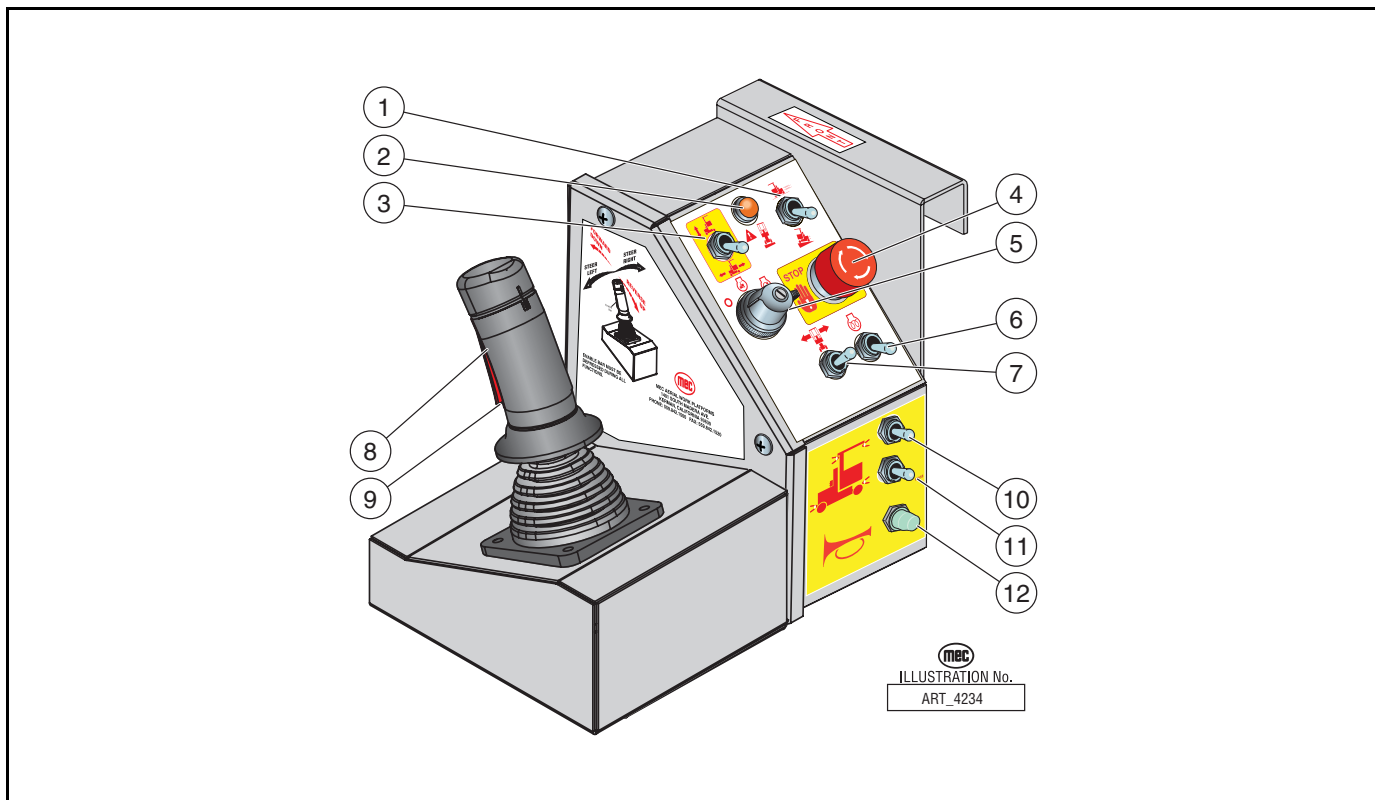

CONTROL		DESCRIPTION
1	Speed/Torque Selector Switch	Move this switch to the up for high speed drive. Push this switch to down for high torque drive.
2	Tilt Indicator Light	If illuminated, the machine is not level. Carefully lower the platform, then move the machine to a firm, level surface.
3	Lift/Drive Switch	Move this switch UP to enable the Lift function. Move this switch DOWN to enable the Drive function.
4	Emergency Stop Switch	Press the EMERGENCY STOP switch at any time to stop all machine functions. Turn switch <i>clockwise</i> to reset
5	Start/Stop Switch	Turn switch fully right to start the engine. Turn switch left to stop the engine.
6	Glow Switch	Move this switch UP to activate glow plugs prior to cold starting the engine.
7	Side Shift Switch	Move this switch LEFT to move the platform left. Move this switch RIGHT move the platform right.
8	Control Handle	DRIVE In Drive Mode, proportionally controls Forward and Reverse travel.
		LIFT In Lift Mode, proportionally controls Lift and Lower functions.
		STEER In Drive Mode, proportionally controls Steer Left and Steer Right by sideways motion.
9	Enable Bar	Squeeze to enable DRIVE, STEER, and LIFT functions from the Control Handle.
10	Platform Light Switch	Operates the work lights mounted on the Platform.
11	Chassis Light Switch	Operates the work lights mounted on the Chassis.
12	Horn Button	Press to sound warning horn.

ALARMS AND SWITCHES

MOVEMENT ALARM

The Movement Alarm is activated as soon as the DOWN operation is activated from the control station. This is the default setting. If desired, the movement alarm setting can be modified to activate the alarm during other functions (refer to *Section 4: Troubleshooting*).



THE MOVEMENT ALARM IS PROVIDED FOR YOUR PROTECTION, AND PROTECTION OF PERSONS WORKING IN THE IMMEDIATE AREA. DISABLING THIS IMPORTANT SAFETY DEVICE MAY RESULT IN SERIOUS INJURY OR DEATH.

PROXIMITY SENSORS

The Proximity Sensors provide information regarding the position of the outer mast to the GP400.

1. Platform Elevated Proximity Sensor -- The GP400 enables the tilt cutout function when the outer mast has clear this switch.
2. Elevation Slow Proximity Switch -- Lift function speed slows after the outer mast clears this switch to prevent cylinder and wear-pad damage .

Figure 2-5: Proximity Sensors

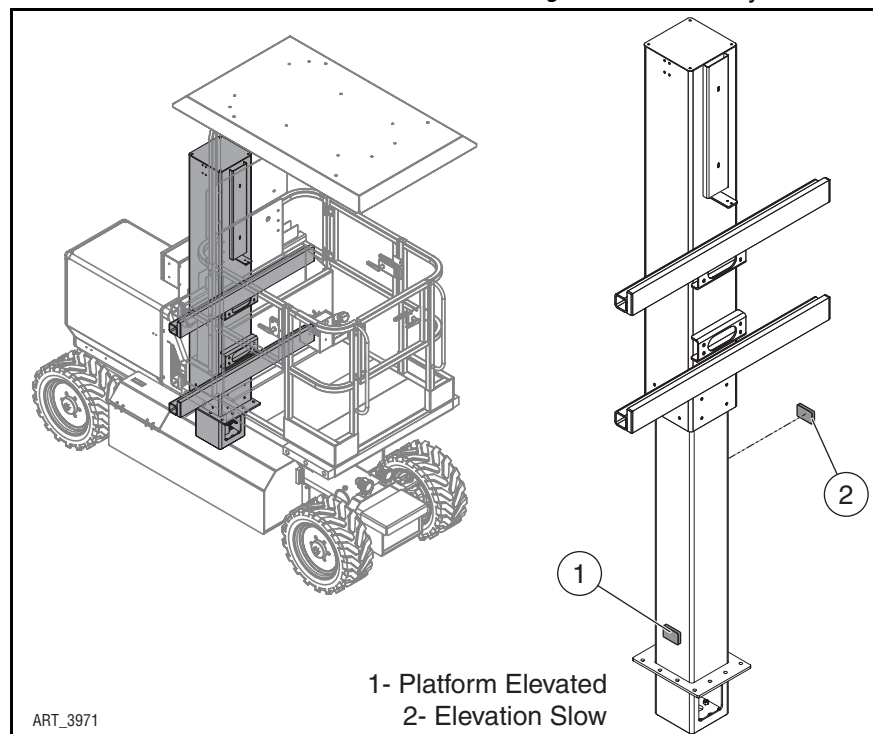

Figure 2-6: Relay Locations**RELAYS**

The relays are located on the engine beneath the throttle solenoid. These relays reduce the current flow through the GP400 Control Module. Refer to the Section 5 for relay functions and interconnect.

START RELAY

Provides power to the starter solenoid.

THROTTLE RELAY

Provides power to the throttle solenoid.

DIESEL GLOW RELAY

Provides power to the diesel engine glow plugs.

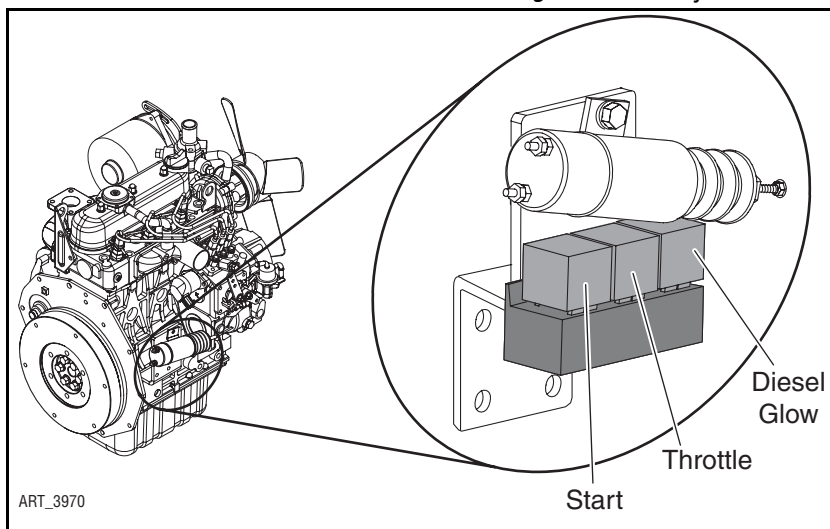

DEUTSCH CONNECTORS

Deutsch connectors used on MEC equipment are designed so that individual parts may be replaced without replacing the entire component. Special tools and detailed instructions are provided in Deutsch Connector field kits, MEC part no. 84091.

Figure 2-7: Deutsch Connectors

MALE PLUG CONNECTOR

- Use the flat end of the Removal Tool or a flat blade screwdriver to pry the locking wedge from the connector, taking care not to damage the Sealing Gasket.
- Inspect and replace damaged parts.
- Replace or re-crimp wires and contacts.

FEMALE RECEPTACLE CONNECTOR

- Use the notched end of the removal tool or a wire hook to pull the locking wedge from the connector
- Replace worn or damaged parts
- Replace or re-crimp wires and contacts.

LOCKING FINGERS

- Remove the locking wedge as outlined above.
- Using the removal tool or a flat blade screwdriver, push the Locking Fingers aside to release the contact.
- Pull the wire and contact out of the connector.

HEAVY DUTY PLUG

- Slide the removal tool along the wire to be replaced and push into the connector to release the contact.
- Pull the wire and contact out of the plug.

CRIMPING

- Strip 1/4 in. (6 mm) insulation from the wire.
- Insert the contact into the crimping tool and insert the stripped wire into the contact making sure no wires are outside the contact barrel.
- Close the handles of the crimping tool, then release the handles to remove the crimped contact.

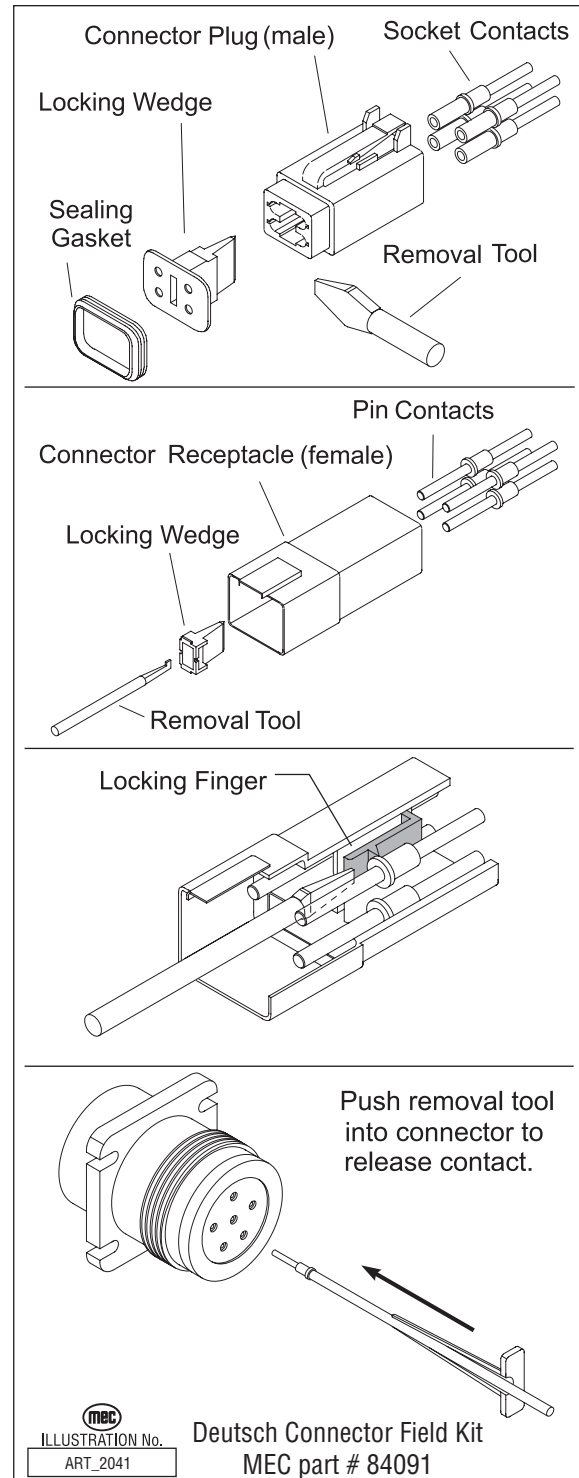

CONTINUITY CHECKS

SELECTOR SWITCH – ON-OFF

- Disconnect wires.
- Connect first probe of ohm meter to *common* terminal.
- Connect second probe to any normally open terminal.
- With switch OFF (open) there should be no reading.
- With the switch ON (closed) there should be a low reading.
- Repeat for each normally open terminal.

Figure 2-8: Selector Switch

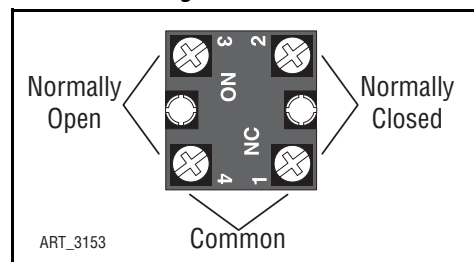

TOGGLE SWITCH – ON-OFF

- Disconnect wires.
- Connect first probe of ohm meter to *common* terminal.
- Connect second probe to normally open terminal.
- With the switch turned OFF there should be no reading.
- With the switch turned ON there should be a low resistance.

Figure 2-9: Toggle Switch, ON-OFF

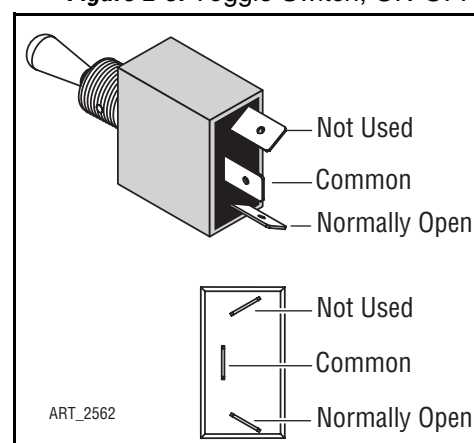

TOGGLE SWITCH – 1-POLE 2-POSITION

- Disconnect wires.
- Connect first probe of ohm meter to *common* terminal.
- Connect second probe to *top* normally open terminal.
- With toggle DOWN there should be no reading.
- With the toggle UP there should be a low resistance.
- Move second probe to *bottom* normally open terminal.
- With toggle UP there should be no reading.
- With the toggle DOWN there should be a low resistance.

Figure 2-10: Toggle Switch, 1-Pole 2-Position

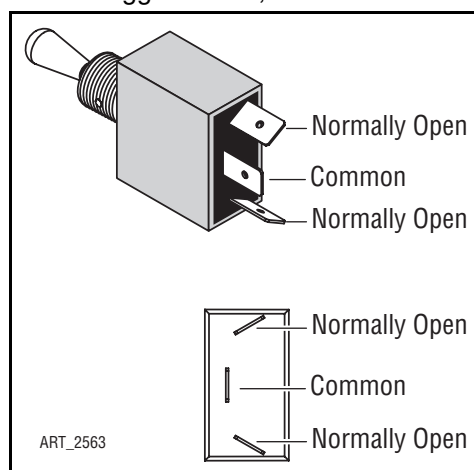

TOGGLE SWITCH – 1-POLE 3-POSITION

- Disconnect wires.
- Connect first probe of ohm meter to *common* terminal.
- Connect second probe of ohm meter to *top* terminal.
- With the toggle UP or MIDDLE there should be a low resistance.
- Move second probe to *bottom* terminal.
- With the toggle DOWN or MIDDLE there should be a low resistance.
- Connect first probe of ohm meter to *top* terminal.
- Connect second probe of ohm meter to *bottom* terminal.
- With toggle in ANY POSITION there should be no reading.

Figure 2-11: Toggle Switch, 1-Pole 3-Position

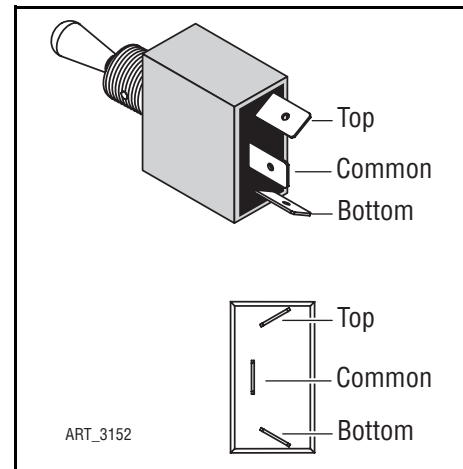

TOGGLE MOMENTARY SWITCH

- Disconnect wires.
- Connect first probe of ohm meter to common terminal.

Test top position

- Connect second probe to *top* normally open terminal.
- With the toggle in the neutral (open) position there should be no reading.
- With the toggle UP (closed) there should be a low resistance.
- With the toggle DOWN (closed) there should be no reading.

Test bottom position

- Move second probe to *bottom* normally open terminal.
- With the toggle in the neutral (open) position there should be no reading.
- With the toggle DOWN (closed) there should be a low resistance.
- With the toggle UP (closed) there should be no reading.
- Repeat for both rows of two-row switch.

Figure 2-12: Toggle Switch, Momentary

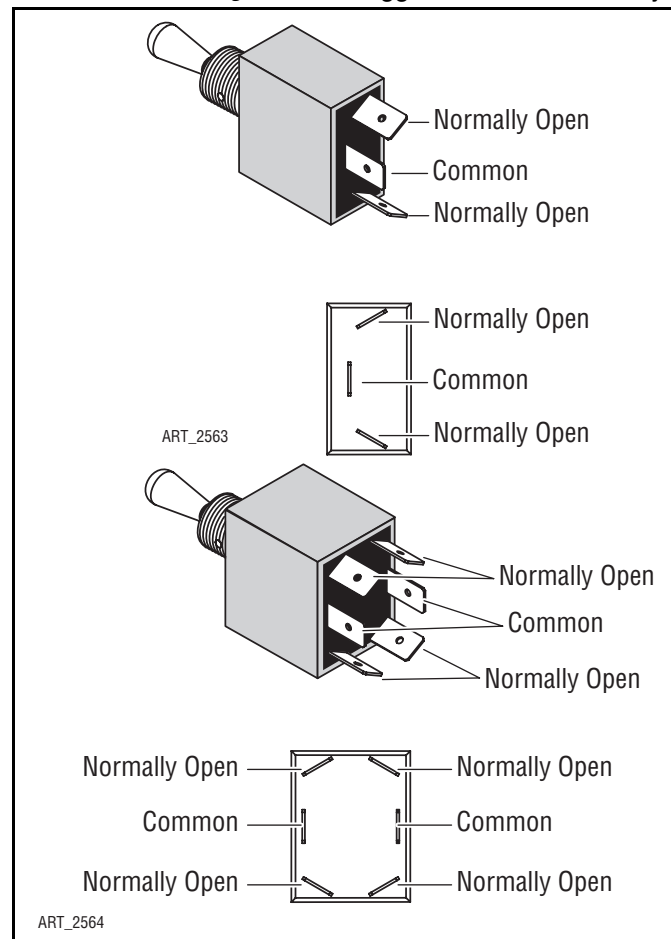
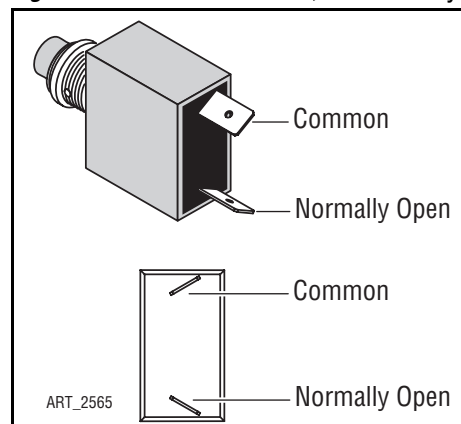

Figure 2-13: Button Switch, Momentary**MOMENTARY BUTTON SWITCH**

- Disconnect wires.
- Connect one probe of ohm meter each terminal.
- With the button in the neutral (open) position there should be no reading.
- With the button pushed (closed) there should be a low resistance



ART_2565

Figure 2-14: Emergency Stop Switch**EMERGENCY STOP BUTTON**

- Disconnect wires.
- Connect one probe of ohm meter each terminal.
- With the button PRESSED there should be no reading.
- With the button RESET there should be a low resistance.

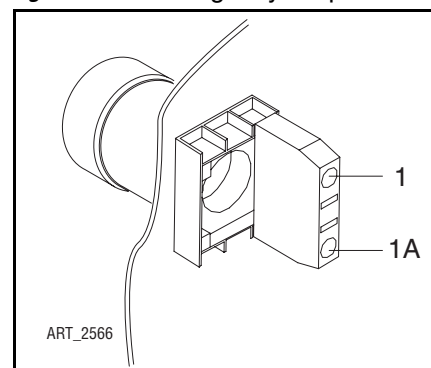

ART_2566

Figure 2-15: Relay Operation**RELAY**

- With the #85 terminal grounded, apply voltage to #86 terminal connection.
- Confirm normally closed (#87A) contacts are opening. Continuity with #30 will be broken.
- Confirm normally open (#87) contacts are closing. Continuity with #30 will be made.

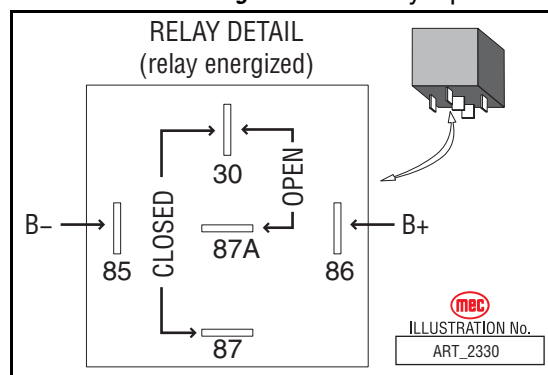

meC
ILLUSTRATION No.
ART_2330

GP400 CONTROL MODULE SETUP

LOCATION

- The GP400 Control Module processor is located in the lower control box.
- The GP400 Matrix Module is located in the upper control box.

Diagnostic information *can be found in Section 4: Troubleshooting*. Wiring information can be found in *Section 5: Schematics*.

Figure 2-16: GP400 Module Locations

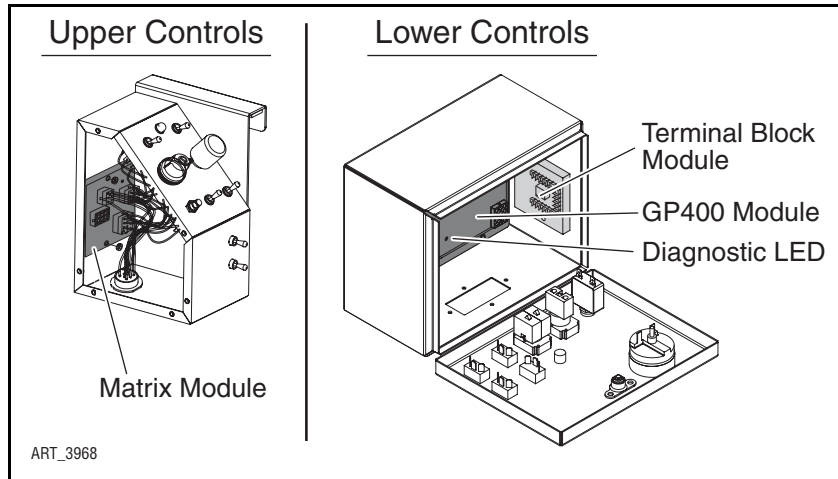

GENERAL DESCRIPTION

The GP400 control module uses a variety of sensors to maintain proper and safe operation of the machine.

In the event the GP400 requires replacement, a calibration process must be performed before the machine can be operated. The GP400 will operate initially in an “assembly mode” to provide basic machine operation. However, it will divert to a failure mode if not properly calibrated within a few start-up cycles.

Figure 2-17: EZ-Cal Connection

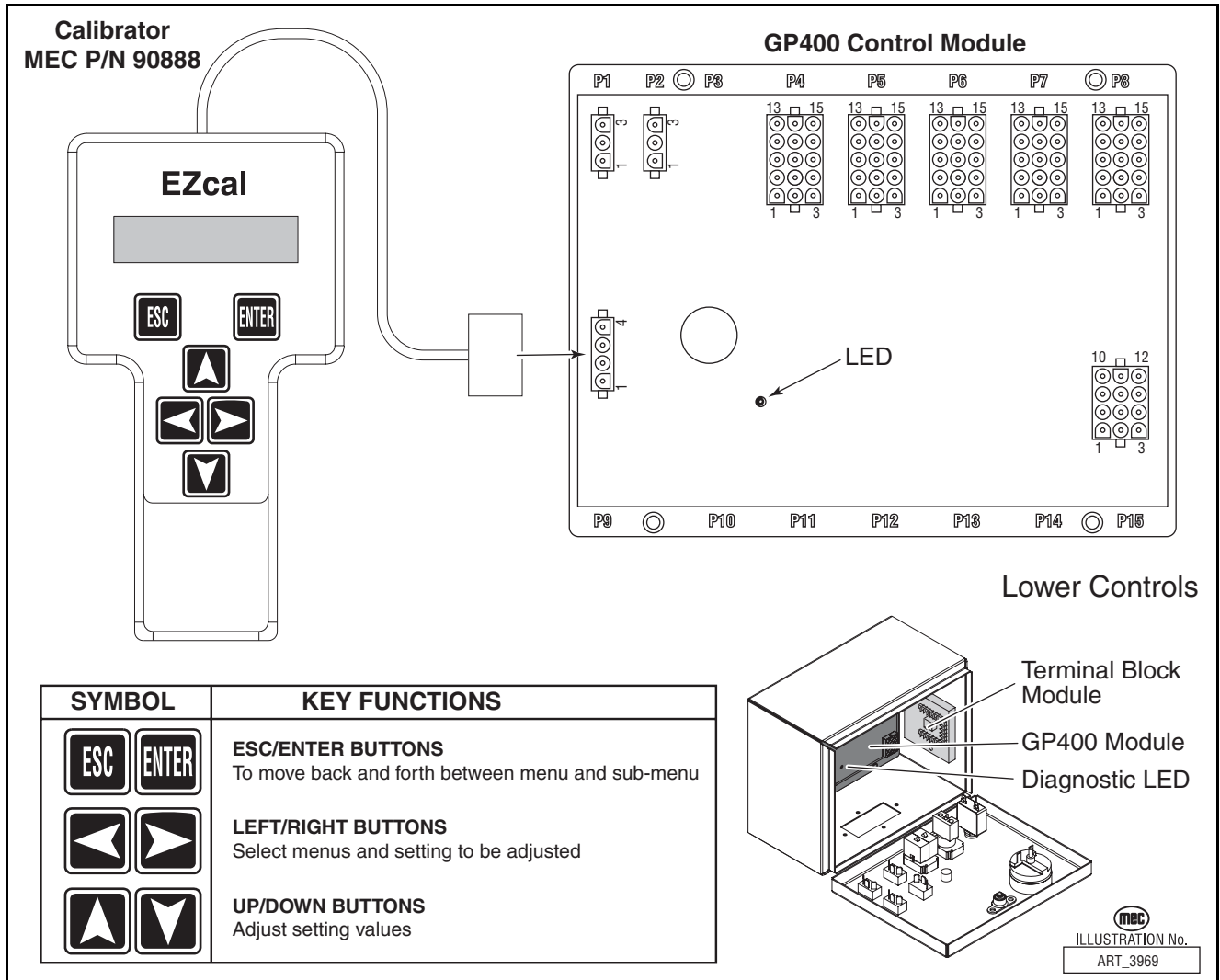

GP400 CALIBRATION



CALIBRATION OF THE GP400 MAY BE PERFORMED ONLY BY QUALIFIED, TRAINED AND AUTHORIZED PERSONNEL. READ ALL INSTRUCTIONS CLOSELY BEFORE ATTEMPTING EACH STEP OF THE CALIBRATION PROCEDURE.

The EZ-Cal hand held device (MEC part # 90888) is required to access the GP400 for troubleshooting and calibration.

The GP400 processor relies on angle and pressure sensors to monitor machine position at all times. These sensors send varied voltages to the GP400 that relate directly to their respective position. The calibration process is the means by which the GP400 equates these voltages to actual machine position.

For example, the Angle Transducer, used to monitor platform elevation, varies its output between 1 and 4 volts through a 140 degree rotation. During calibration the GP400 may learn that 1.8 volts (fictional number used for explanation) represents the fully stowed position and 3.6 volts represents the fully elevated position and therefore voltages between those figures relate to various heights in between.

All machines are calibrated at the factory and should not require calibration unless the GP400 is replaced or if the GP400 displays a code that alerts to the need to recalibrate.

Tilt Sensor calibration is required on all machines regardless of destination or certification (ANSI or CE) and must be performed first.

ANSI calibration follows Tilt calibration for machines not equipped with an overload protection system and consists of only height calibration.

CE calibration is required of all machines outfitted with an Overload Protection System as required for CE certification. All steps in the CE calibration must be performed in the proper sequence before the GP400 will recognize complete and proper calibration. Begin with the ANSI/CE Tilt Sensor Calibration, then proceed to the CE Calibrations section.

If the calibration procedure is performed incorrectly or there is a failure in one of the monitored circuits during the calibration, the GP400 will not allow the operator to continue with the calibration process. An error message will display on the EZ-cal indicating the reason for the interruption.

Additional details of these error messages can be found at the end of the calibration instructions.

This and other procedures can only be performed using an EZ-Cal scan tool. If you do not have an EZ-Cal, please contact MEC to obtain one.

ANSI/CE Tilt Sensor Calibration

Correctly performing the following procedure will ensure that your machine will continue to auto-level correctly and operate safely.

The automated leveling system relies on the information provided by three sensors:

- The platform tilt sensor (Platform CAN Tilt Angle Transducer) is used to level the platform to within 0.2 degrees of absolute level when auto-leveling. It is also use by the control system to

monitor platform level status for enhanced unit stability. The platform tilt sensor is located inside the Lower Boom Mount.

- The axle sensor (Axle CAN Tilt angle transducer) which is mounted to the front oscillating axle provides information as to the position of the axle relative to the chassis. This information is used to allow or disallow drive when the platform is in the elevated position. If the front axle is more than 3 degrees out of parallel with the chassis, drive will be turned off to prevent the loss of stability.
- The third level sensor is located inside the GP400 and monitors the chassis angle. All three sensors will calibrate at one time during the calibration procedure.

1. Park machine on a flat level surface.
2. Be sure that all tires are properly inflated to the same pressure and that the tires are all the same size.
3. Ensure that the platform is perfectly level side-to-side and front-to-rear by using the two Manual Level Switches located in the upper control box and a spirit level. Use a framers level if necessary.
4. Open the lower control box and plug the EZ-cal into plug J-9 (4-pin connector) on the GP400. The display should light up and read "HELP - PRESS ENTER."
 - a. Press the right arrow to access "ACCESS LEVEL 3", press ENTER.
 - The display reads CODE 0000 with the cursor flashing.
 - b. Press the Up and Right arrows to enter code 2222, Press Enter
 - Display reads "ACCESS LEVEL 2"
 - On later models, the display may continue to read "ACCESS LEVEL 3". Repeat step b. and enter code 1775.
 - c. Right arrow to SETUPS, Press Enter
 - Display reads 'CHANGE DEFAULTS'
 - d. Right arrow to TILT SETUPS, Press Enter
 - Display reads "CALIBRATE LEVEL".
 - e. Press Enter
 - Display reads "CALIBRATE LEVEL YES: ENTER NO: ESC"
 - f. Press Enter
 - Display reads "CALIBRATE LEVEL YES: ENTER NO: ESC" plus has actual tilt percentages.
 - g. Press Enter again.
 - The percentage numbers should be 0.0 - 0.0 (or very close).

CALIBRATION PROBLEMS

FAILURE MESSAGES

Various problems can be detected by the EZ-Cal that prevent successful calibration. These problems are reported with a flashing message including an “F” code. The following descriptions are helpful in solving the problem. References in parentheses refer to electrical schematic points.

F01:CHECK HWFS

This message is given if the startup tests have not completed.

Check HELP message for more information.

F02:NOT GROUND MODE

This message is given if the machine is not in ground mode (P7-2 must be high). Calibration can only be carried out in ground mode.

F03:NOT STOPPED

This message is given if any function switch is closed. Check DIAGNOSTICS / SWITCHES to see which function switch is closed.

F04:TILTED

This message is given if the machine is tilted. Calibration must be carried out with the machine level. If the machine is level, perform the Tilt Calibration procedure above.

F05:BAD HEIGHT

This message is given if the height sensor output (P8-2 and P8-6) is out of range at the start of calibration. The height sensor output must be between 1.0V and 4.0V. Check DIAGNOSTICS / SENSORS to see the output. A reading of 0V or 5V is probably due to a wiring problem.

F06:CHECK ELEV

This message is given if the elevation switch (P7-5) is open at the start of calibration, when the operator has confirmed the “PLATFORM DOWN?” question.

If the platform is down, check the elevation switch wiring.

F08:CHECK ELEV

This message is given if the elevation switch (P7-5) is closed at the end of the DYNAMIC lift, when the platform should be fully raised.

This message would occur if the UP switch was accidentally opened near the start of the DYNAMIC lift.

If the platform is fully raised, check the elevation switch wiring.

F09:BAD HEIGHT

This message is given if the height sensor output (P8-2 and P8-6) is out of range at the start of the DYNAMIC lift. The height sensor output must be between 1.0V and 4.0V. Check DIAGNOSTICS / SENSORS to see the output. This is usually due to a wiring problem.

F10:BAD HEIGHT

This message is given if the height sensor output (P8-2 and P8-6) is out of range at the end of the DYNAMIC lift. The height sensor output must be between 1.0V and 4.0V. Check DIAGNOSTICS / SENSORS to see the output. A reading of 0V or 5V is probably due to a wiring problem.

F11:NOT UP

This message occurs at the start of the DYNAMIC lift if the operator selects a function other than UP.

F12:TOO MANY

This message occurs if the DYNAMIC lift takes too long.

This message could occur if the UP switch was not released at the end of the dynamic lift.

F13:LOW HEIGHT RANGE

This message occurs at the end of the DYNAMIC lift if the height sensor output did not change sufficiently to give a reasonably accurate platform height estimate. DIAGNOSTICS / ANALOGS can be used to check the height sensor output (P8-2 and P8-6) when the platform is fully lowered and fully raised; a difference of at least 1V is to be expected.

This message could occur if the UP switch was accidentally opened too early (when the platform is not fully raised).

F14:BAD HEIGHT

This message occurs if the height sensor output (P8-2 and P8-6) is out of range during the DYNAMIC lift. The height sensor output must be between 1.0V and 4.0V. Check DIAGNOSTICS / SENSORS to see the output. A reading of 0V or 5V is probably due to a wiring problem.

F15:CHECK ELEV

This message is given if the elevation switch (P7-5) is open when the platform has been fully lowered after the DYNAMIC lift.

This message would occur if the DOWN switch was accidentally opened before the platform was fully lowered.

If the platform is fully lowered, check the elevation switch.

F16:LOW ELEV.OPEN

This message is given if the elevation switch (P7-5) opened during lift at too low of a height (below 5%). Check CALIBRATIONS / HEIGHT CALS. The "ElevUp" value shows the recorded height where the switch opened.

F17:HIGH ELEV.OPEN

This message is given if the elevation switch (P7-5) opened during lift at a too high height (above 25%).

Check CALIBRATIONS / HEIGHT CALS; the "ElevUp" value shows the recorded height where the switch opened.

F18:LOW ELEV.CLOSE

This message is given if the elevation switch (P7-5) closed during lower at a too low height (below 5%).

Check CALIBRATIONS / HEIGHT CALS; the "ElevDown" value shows the recorded height where the switch opened.

F19:HIGH ELEV.CLOSE

This message is given if the elevation switch (P7-5) closed during lower at a too high height (above 25%).

Check CALIBRATIONS / HEIGHT CALS; the "ElevUp" value shows the recorded height where the switch opened.

F20:HEIGHT<>0%**F21:HEIGHT<>0%**

This message occurs if the platform height is not 0% after the platform has been fully lowered at the end of a calibration step. The platform must return to the same height each time it is fully lowered.

Check DIAGNOSTICS / SYSTEM to check the height.



F22:HEIGHT<>100%
F23:HEIGHT<>100%

This message occurs if the platform height is not 100% after the platform has been fully raised during a calibration step. The platform must return to the same height each time it is fully raised. Check DIAGNOSTICS / SYSTEM to check the height.

F24:TOO MANY

This message occurs if too many static measurements are taken during a calibration step. In the rare event that this occurs, please call MEC for assistance.

F25:CHECK ELEV
F26:CHECK ELEV

This message indicates a problem with the elevation switch (P7-5) during the STATIC phases.

The switch is either staying closed to a higher height, or staying open to a lower height, than that recorded during the DYNAMIC phase.

F27:BAD HEIGHT

This message indicates a problem with the height sensor output (P8-2 and P8-6) during the STATIC calibration phases.

The height sensor output must be between 1.0V and 4.0V at all times.

Check DIAGNOSTICS / SENSORS to see the output. A reading of 0V or 5V is probably due to a wiring problem.

F30:BAD HEIGHTS

This message indicates that the recorded heights are not increasing during STATIC lift, or are not decreasing during STATIC lower.

This problem may be caused by repeatedly opening and closing the UP or DOWN switch during the STATIC phases.

F31:REJECT CURVE

The DYNAMIC pressure curve is unacceptable.

An initial pressure peak when the platform lifted cannot be found between 0% and 15% height.

Check for proper weight in the platform and check pressure sensor and lift cylinder hydraulics.

F32:REJECT CURVE

The DYNAMIC pressure curve is unacceptable.

There should be a lowest pressure about halfway through the lift (i.e.: near 50% height); the lowest pressure measured is at too low a height.

Check for proper weight in the platform and check pressure sensor and lift cylinder hydraulics.

F33:REJECT CURVE

The DYNAMIC pressure curve is unacceptable.

There should be a lowest pressure about halfway through the lift (i.e.: near 50% height); the lowest pressure measured is at too high a height.

Check for proper weight in the platform and check pressure sensor and lift cylinder hydraulics.

F34:REJECT CURVE

The DYNAMIC pressure curve is unacceptable.

There is not enough difference between the initial pressure peak and the minimum pressure.

Check for proper weight in the platform and check pressure sensor and lift cylinder hydraulics.

F40:REJECT DELTA

This message indicates that there is not enough difference between the loaded & empty pressure.

This message could occur if the platform were not properly loaded during the STATIC LOADED phase, or if the platform were not properly empty during the STATIC EMPTY phase.

This message could also occur if the wrong pressure sensor was fitted (e.g.: a 5000psi sensor when a 3000psi one is needed).

Check CALIBRATIONS / HEIGHT CALS; the "Height" indicates the first height at which there was insufficient difference and the "Up" and "Down" values show the loaded pressure (first) and the difference between loaded and empty pressure (second).

F42:LOW PRESSURE

This message indicates that the pressure is too low (0.5V or less) when the elevation switch opens during the DYNAMIC lift.

This message would occur if the pressure sensor was disconnected, or if there were some other wiring error.

Check DIAGNOSTICS / SENSORS to check the pressure.

F43:HIGH PRESSURE

This message indicates that the pressure is too high (4.5V or more) when the elevation switch opens during the DYNAMIC lift.

This message would occur if the wrong pressure sensor was fitted, or if there were some other wiring error.

Check DIAGNOSTICS / SENSORS to check the pressure.

F44:LOW PRESSURE

This message indicates that the pressure is too low (0.5V or less) at a STATIC measurement point.

This message would occur if the pressure sensor was disconnected, or if there were some other wiring error.

Check DIAGNOSTICS / SENSORS to check the pressure.

F45:HIGH PRESSURE

This message indicates that the pressure is too high (4.5V or more) at a STATIC measurement point.

This message would occur if the wrong pressure sensor was fitted, or if there were some other wiring error.

Check DIAGNOSTICS / SENSORS to check the pressure.

F46:CHECK ELEV

This message indicates that the elevation switch opened more than once during the DYNAMIC lift.

F47:CHECK ELEV

This message indicates that the elevation switch closed more than once during the DYNAMIC lower.



F48:BAD PRESSURE

This message is given if the pressure sensor output (P8-2 and P8-6) is out of range at the start of calibration.

The height sensor output must be between 0.5V and 4.5V.

Check DIAGNOSTICS / SENSORS to see the output. A reading of 0V or 5V is probably due to a wiring problem.

F52:NOT CALIBRATED

This message is a catch-all code which indicates an improper calibration sequence or that one of the phases of calibration was not completed. The skipped phase must be completed or the calibration sequence must be passed through in proper sequence before this message will clear. Re-start the calibration sequence and proceed through each sequence in the specified order.

A "Redo" prompt will appear before each sequence. Answer "NO" if there is no reason to repeat or "YES" if the phase must be completed.

INFORMATION MESSAGES

During calibration the following messages will be displayed. They are informational prompts only and do not indicate a failure.

BUILDING TABLES

This message indicates that the STATIC measurements are being used to build calibration data - the process should take no more than 5s.

CALDATE:

This message is prompting for the date to be entered; it is stored to identify when the machine was calibrated.

The last calibrate date can be viewed in DIAGNOSTICS / LOG.

Press LEFT & RIGHT to select the flashing digits.

Press UP & DOWN to change the flashing digits.

Press ENTER when the entry is complete.

IMPORTANT: The date 00/00/00 is not allowed!

FINISHED

This message confirms that calibration is complete and successful.

GO DOWN MORE!

This message occurs if the DOWN switch is released during either STATIC lowering phase, when more measurements are needed (before the platform is fully lowered).

GO UP MORE!

This message occurs if the UP switch is released during either STATIC lifting phase, when more measurements are needed (before the platform is fully raised).

LIFT EMPTY

This message is displayed during the STATIC empty phase while the platform is being raised to the next measurement height.

LIFT LOADED

This message is displayed during the STATIC loaded phase while the platform is being raised to the next measurement height.

LIFTING

This message is displayed during the DYNAMIC phase while the platform is being raised.

LOWER EMPTY

This message is displayed during the STATIC empty phase while the platform is being lowered to the next measurement height.

LOWER LOADED

This message is displayed during the STATIC loaded phase while the platform is being lowered to the next measurement height.

LOWERING

This message is displayed during the DYNAMIC phase while the platform is being lowered.

MEASURING #

This message is displayed when the platform is stopped during either STATIC phase, when the GP400 takes a measurement.

There will be a short delay while the machine is allowed to stabilize after movement is stopped.

MUST GO DOWN!

This message occurs if the wrong switch is operated when the GP400 is waiting for the platform to be lowered.

MUST GO UP!

This message occurs if the wrong switch is operated when the GP400 is waiting for the platform to be raised.

PLATFORM DOWN?

This message is prompting for confirmation that the platform is fully lowered. If necessary the DOWN switch can be activated to lower the platform.

Press ENTER to confirm when the platform is fully lowered.

PLATFORM EMPTY?

This message is prompting for confirmation that the platform is completely empty.

Press ENTER to confirm when the platform is empty.

PLATFORM LOADED?

This message is prompting for confirmation that the platform is loaded to rated load of 600 lbs (US/CSA). (100% of the load rating listed on the serial plate).

Press ENTER to confirm when the platform is loaded.

PLEASE LIFT ...

This message is prompting for the platform to be raised.

The UP switch should be operated.

PLEASE LOWER ...

This message is prompting for the platform to be lowered.

The DOWN switch should be operated.

PLEASE WAIT

This message indicates that the is busy; the delay will be short (no more than 5s).

REDO DYNAMIC:

This message is displayed if the DYNAMIC phase of load calibration has previously been completed.

Press ENTER when "NO" is displayed if there is no need to redo the DYNAMIC phase.

Press UP or DOWN to display "YES" then press ENTER if it is necessary to redo the DYNAMIC phase.

If the previous DYNAMIC calibration was in error, or if the height or pressure sensor is replaced, it will be necessary to redo the DYNAMIC phase.

REDO EMPTY:

This message is displayed if the EMPTY phase of load calibration has previously been completed.

Press ENTER when "NO" is displayed if there is no need to redo the EMPTY phase.

Press UP or DOWN to display "YES" then press ENTER if it is necessary to redo the EMPTY phase.

If the previous EMPTY calibration was in error, or if the pressure sensor is replaced, it will be necessary to redo the EMPTY phase.

REDO LOADED:

This message is displayed if the LOADED phase of load calibration has previously been completed.

Press ENTER when "NO" is displayed if there is no need to redo the LOADED phase.

Press UP or DOWN to display "YES" then press ENTER if it is necessary to redo the LOADED phase.

If the previous LOADED calibration was in error, or if the pressure sensor is replaced, it will be necessary to redo the LOADED phase.

TOTAL DATA:

This message is displayed at the end of each phase, to confirm the number of measurements recorded by the GP400. No operator input is required during this process.

NOTES:



Section 3

MECHANICAL COMPONENTS

CONTENTS	PAGE
Mechanical Components	3-2
Base	3-2
Tires and Wheels	3-2
Hoses and Cables	3-3
Drive Motors	3-4
Steer Cylinders	3-7
Platform Side Shift Cylinders	3-9
Platform	3-11
Lift Cylinder and Mast	3-13
Lubrication	3-23
Engine Maintenance	3-24

FIGURES	PAGE
Wheel Removal	3-4
Hub Removal	3-4
Steering Linkage	3-5
Motor Removal	3-5
Hub Removal	3-6
Cover Plate	3-7
Steering Linkage	3-8
Steer Cylinder	3-8
Side Shift Cylinder -- Rod End	3-9
Side Shift Cylinder -- Barrel End	3-10
Canopy Removal	3-11
Platform Removal	3-12
Platform Slide Pads	3-12
Lubrication Points	3-23
Engine	3-24
Diesel Engine Fuel Filter	3-25
Diesel Engine Throttle Adjustments	3-26



MECHANICAL COMPONENTS

This section describes the major components of the machine and the steps required to service them.

BASE



When steam cleaning the base/undercarriage, cover electrical components to prevent water penetration.

Steam clean the base as necessary, and inspect all welds and brackets. Check for cylinder pins that have turned in their mounting, which may indicate sheared retaining pins.

TIRES AND WHEELS

Inspect for cuts, chunking, side-wall damage, or abnormal wear. **ANY TIRE FAULTS MUST BE CORRECTED** before further machine operation. Refer to Parts sections for replacement tires.



FAILURE TO USE APPROVED PARTS MAY CAUSE DEATH OR SERIOUS PERSONAL INJURY.

REPLACE TIRES WITH THE CORRECT TIRES TO MAINTAIN THE RATING OF THE EQUIPMENT.

IF FOAM FILLED TIRES WERE FITTED AS ORIGINAL EQUIPMENT THEY MUST BE REPLACED WITH EQUIVALENT SPECIFICATION TIRES AND FOAM-FILL WEIGHT.

CHANGING TIRES

Refer to *“Lift and Support The Machine”* in the *Introduction* section for instructions and safety precautions.



Always block the wheels before lifting the machine.

1. Chock tires on the end of machine opposite the tire to be changed.
2. Break loose but **do not remove** lug nuts before raising the machine.
3. Lift the end of machine requiring a tire change and support with jackstands of adequate capacity.
4. Remove lug nuts and pull the wheel off.
5. Install the replacement wheel.
6. Install lug nuts and tighten.
7. Lower the machine.
8. Tighten lug nuts to proper torque (Refer to machine specifications).
9. Remove the chocks.

HOSES AND CABLES

NOTE: Refer to *Parts Section E* for detailed hydraulic hose diagrams.

Inspect all hoses and electrical cables for security and damage. Hoses and cables should be examined for rubbing and chafing.

Check all ties and clamps that keep hoses secure.

Check for leaks at fittings. Replace any damaged hose or cable.

1. Tag hoses for proper reassembly.
2. Disconnect hydraulic hoses. Immediately cap and plug all openings to prevent contamination.
3. Torque hose fittings according to the Hydraulic Torque Specification Table. See the Introduction section of this manual.

DRIVE MOTORS

There are four hydraulic drive motors on this machine. Repair or replace as necessary when damage or leaks occur.



- Clean all fittings before disconnecting hoses.
- Tag hoses for proper reassembly.
- Plug all openings immediately to prevent contamination.

Refer to “Lift and Support The Machine” in the *Introduction* section for instructions and safety precautions.

Removal

1. Raise and support the front end of machine.
2. Remove the wheel and tire assembly.
3. Disconnect hose assemblies from drive motor. Immediately cap and plug all openings to prevent contamination.

Figure 3-1: Wheel Removal

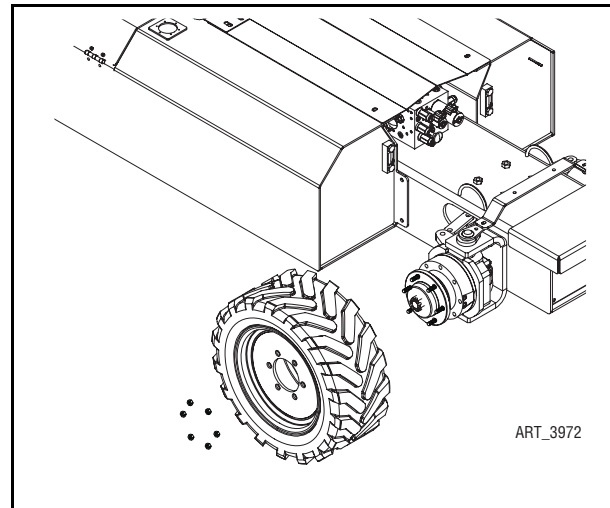

4. Remove the hub from the drive motor:
 - Remove the cotter pin from the castle nut.
 - Use a suitable hub pulling tool. DO NOT use a hammer on the shaft or hub as this will damage the motor.
 - Remove the shaft key

Figure 3-2: Hub Removal

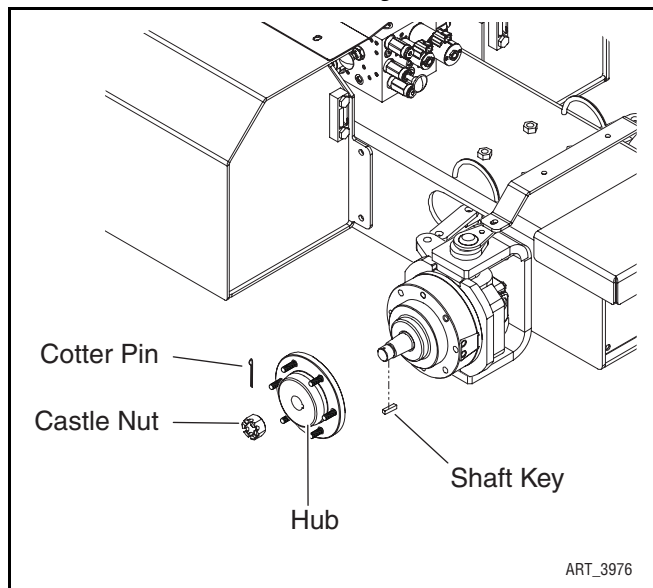
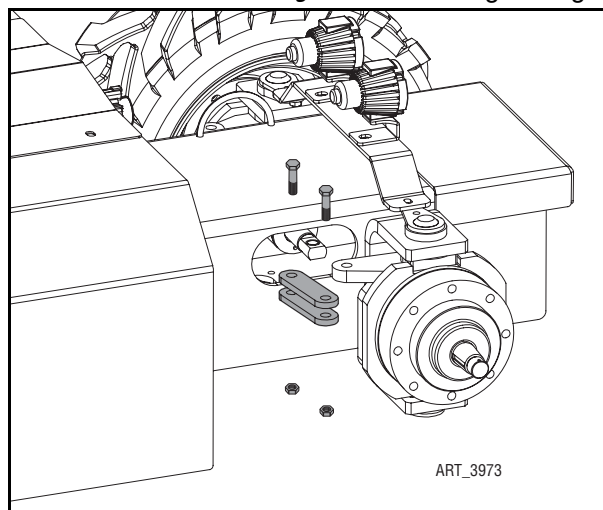

Figure 3-3: Steering Linkage

5. Disconnect the steering linkage from the motor assembly and steer cylinder.

**Figure 3-4: Motor Removal**

6. Remove the motor assembly:
- Support the motor assembly.
 - Remove the driving light mounting bar (front axle only).
 - Remove the lower king pin.
 - Remove the upper king pin.
 - Using a thin screwdriver, slide the thrust washer out from between the motor assembly and the upper frame member.



DO NOT PLACE YOUR FINGERS BETWEEN THE MOTOR ASSEMBLY AND THE FRAME.

- Carefully remove the motor assembly.

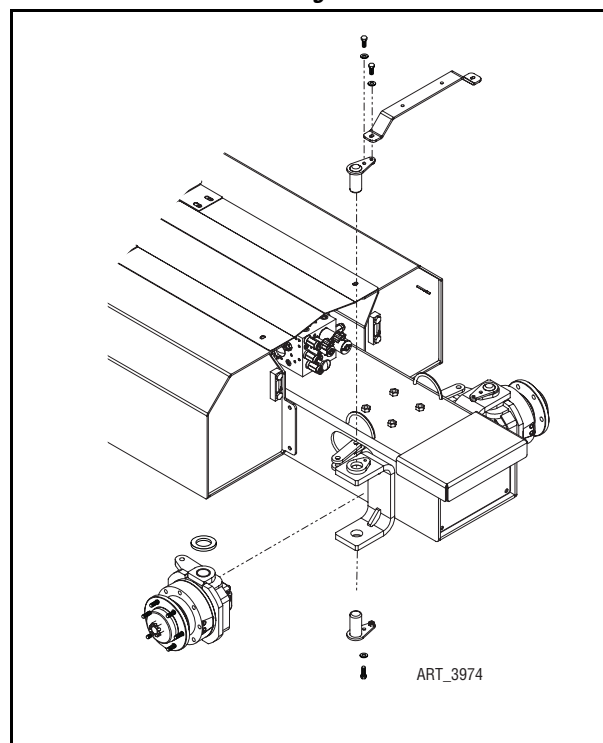

Figure 3-5: Hub Removal

7. Remove the cap screws and remove the drive motor.
8. Remove and replace the king pin bearings if necessary.

Installation

Installation is reverse of removal.

- Use Loctite 242 or equivalent on mounting bolts.

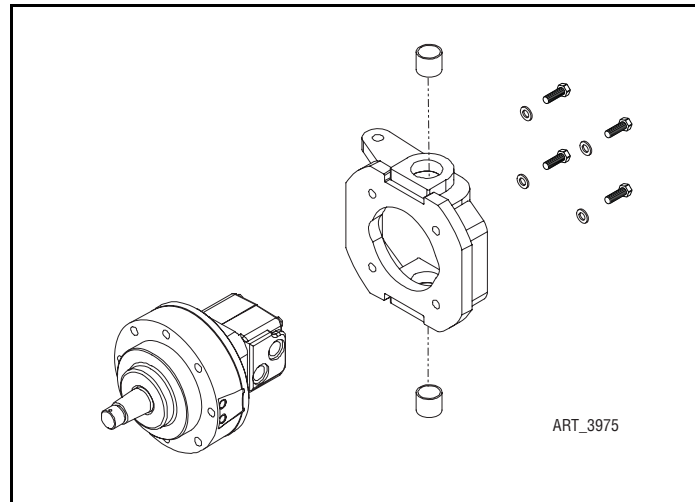

STEER CYLINDERS

There is one double acting type steer cylinder on this machine, one located at each end of the machine. During operation, the cylinder should not leak, but a slight damping at the rod seal is acceptable. The pins should be checked for wear.



- Clean all fittings before disconnecting hoses.
- Tag hoses for proper reassembly.
- Plug all openings to prevent contamination.

Refer to “*Lift and Support The Machine*” in the *Introduction* section for instructions and safety precautions.

Refer to Section 1 for hose connections and seal replacement instructions.

Removal

1. Raise and support the machine.
2. Remove the wheels from the end of the machine to be repaired.
3. Remove the cover plate. Disconnect hydraulic hoses from the steer cylinder. Immediately cap and plug all openings to prevent contamination.

Figure 3-6: Cover Plate

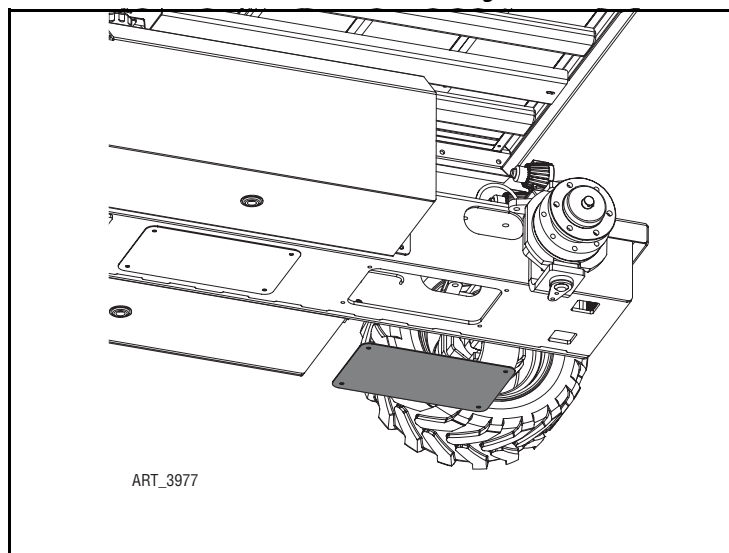
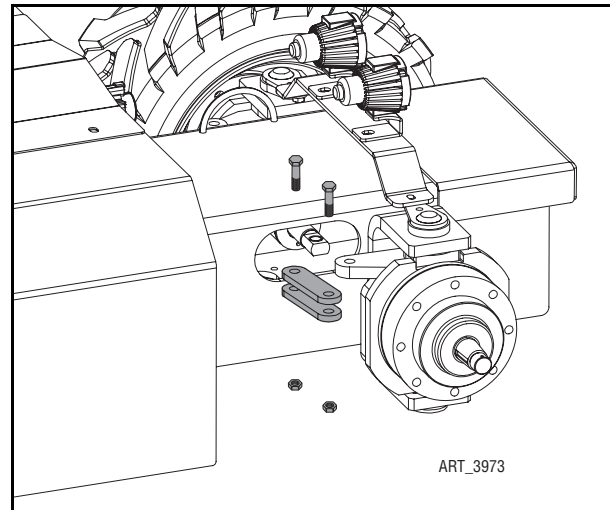

Figure 3-7: Steering Linkage

4. Disconnect the steering linkage from the steer cylinder.

**Figure 3-8: Steer Cylinder**

5. Remove the four bolts holding the steer cylinder to the chassis.
6. Carefully remove the steer cylinder from the chassis.

Installation

Installation is reverse of removal.

- Use Loctite 242 or equivalent on mounting bolts.
- To purge air from cylinder, cycle the steering system fully left and right 4-5 times.

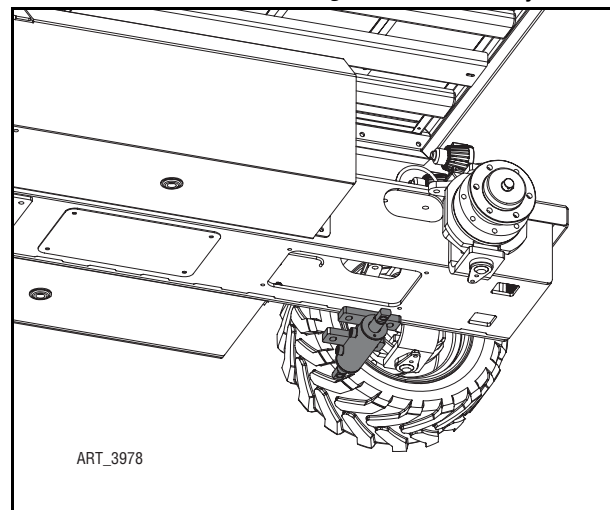

PLATFORM SIDE SHIFT CYLINDERS

There are two Side Shift Cylinders located between the platform and mast.

Park the machine on a level surface before performing this procedure. It is not necessary to remove the platform to remove the Platform Side Shift Cylinders.

However, with the Platform Side Shift Cylinders removed, the platform will move freely.

Refer to Section 1 for hose connections and seal replacement instructions.



- Clean all fittings before disconnecting hoses.
- Tag hoses for proper reassembly.
- Plug all openings to prevent contamination.

REMOVAL

1. Park the machine on a level work surface.
2. Disconnect hydraulic hoses and hard lines. Immediately cap and plug all openings to prevent contamination.
3. Remove the bolts that secure the rod end of the cylinder to the platform.
 - Note the position of the thick and thin spacer blocks for reassembly.

Figure 3-9: Side Shift Cylinder -- Rod End

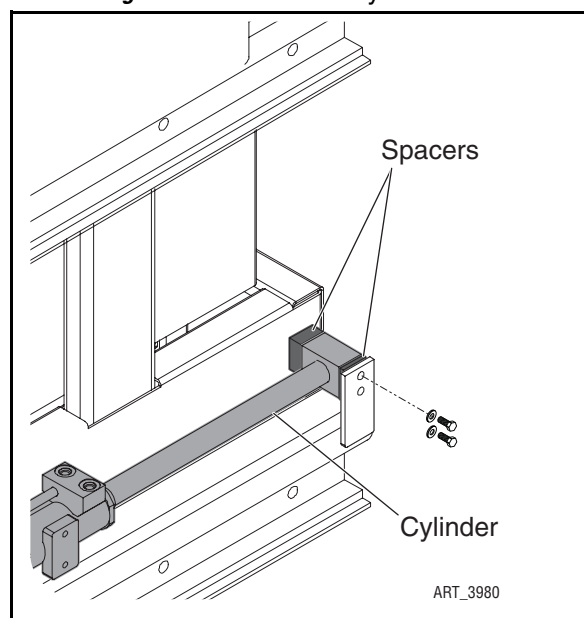

ART_3980

Figure 3-10: Side Shift Cylinder -- Barrel End

4. Remove the bolts that attach the cylinder to the mast.
5. Slide the cylinder out from between the platform and the mast.

NOTE: It is not necessary to remove the platform to remove the Platform Side Shift Cylinders.

Installation

Installation is reverse of removal.

- Use Loctite 242 or equivalent on mounting bolts.
- To purge air from cylinder, cycle the platform side shift system fully left and right 4-5 times.

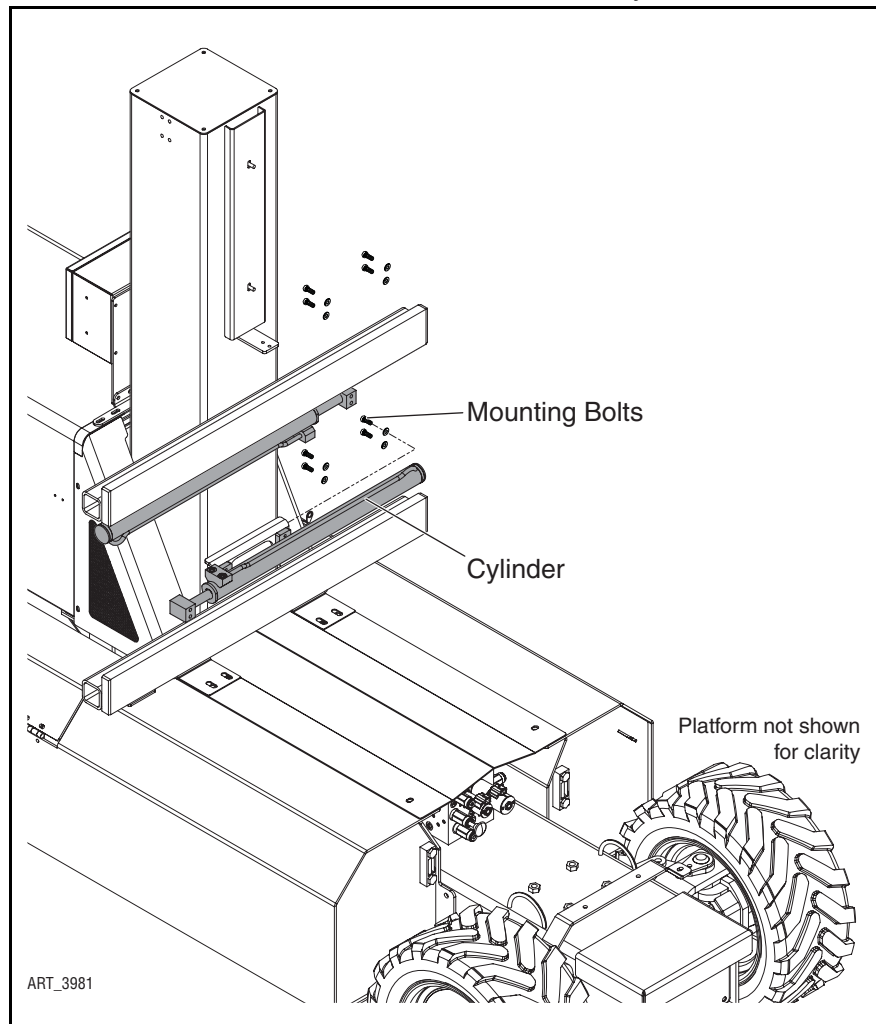

PLATFORM

The platform must be removed to dismantle the mast assembly, and to inspect and replace the platform slide pads.

Refer to Section B of this manual for Platform parts.



HEAVY COMPONENTS. USE AN OVERHEAD CRANE OR APPROPRIATE LIFTING DEVICE OF ADEQUATE CAPACITY TO MOVE THE COMPONENTS. THIS PROCEDURE SHOULD BE PERFORMED ONLY BY QUALIFIED, AUTHORIZED AND EXPERIENCED PERSONNEL.

Removal

1. Remove the Platform Side Shift Cylinders (see "Platform Side Shift Cylinders" on page 3-9).
2. Tag and disconnect the cables connecting to the platform and canopy.
3. Remove the canopy.

Figure 3-11: Canopy Removal

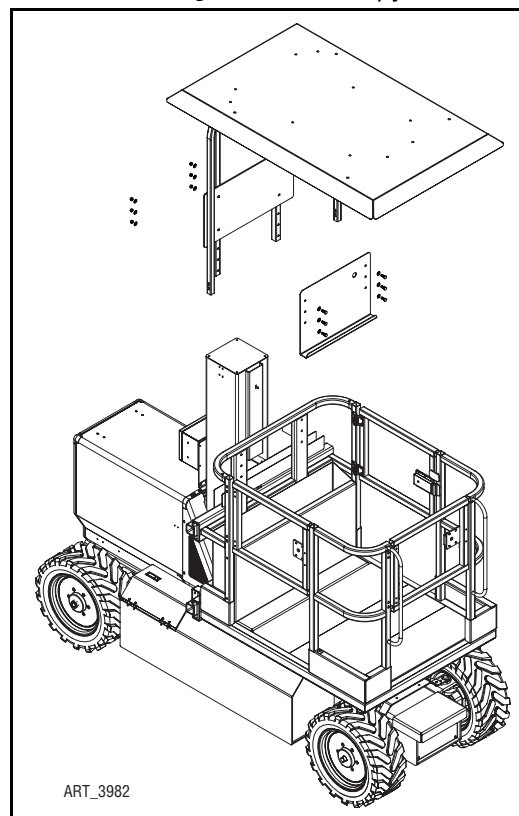

Figure 3-12: Platform Removal

4. Connect an overhead crane or appropriate lifting device to the platform.
5. Slide the platform off the mast rails.

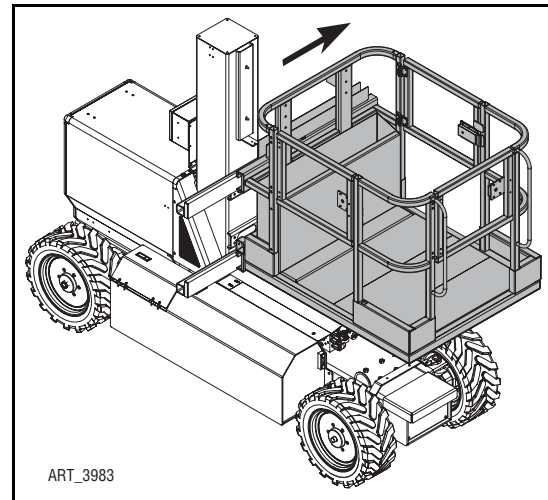

Figure 3-13: Platform Slide Pads

6. Replace the platform slide pads if necessary.

Installation

Installation is reverse of removal.

- Use Loctite 242 or equivalent on mounting bolts.

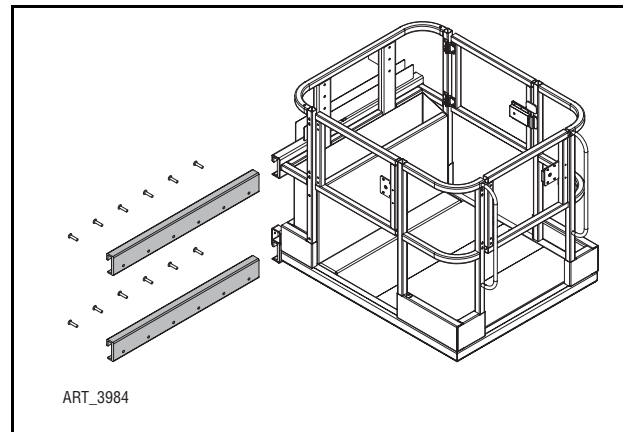

LIFT CYLINDER AND MAST

! WARNING

HEAVY COMPONENTS. THIS PROCEDURE SHOULD BE PERFORMED ONLY BY QUALIFIED, AUTHORIZED AND EXPERIENCED PERSONNEL. USE AN OVERHEAD CRANE OR APPROPRIATE LIFTING DEVICE OF ADEQUATE CAPACITY TO MOVE THE COMPONENTS.

! CAUTION

- Clean all fittings before disconnecting hoses.
- Tag hoses for proper reassembly.
- Plug all openings to prevent contamination.

DISASSEMBLY

This procedure covers the complete disassembly of the mast. This procedure should not be necessary unless the mast has been structurally damaged.

Other repairs may be necessary that will require partial use of this procedure. These repairs include:

- Replacing the lift cylinder
 - Replacing the platform side shift hoses
 - Replacing the electrical cables serving the platform
 - Replacing the mast wear pads
1. Remove the platform (see "Platform" on page 3-11).
 2. Remove the machine base cover and engine side covers.
 3. Remove the center access cover on the bottom of the machine.
 4. Tag and disconnect the hydraulic hose connected to the base of the lift cylinder.

NOTE: Immediately cap and plug all openings.

5. Tag and disconnect the base ends of the platform side shift hydraulic hoses that are routed through the mast.

NOTE: Immediately cap and plug all openings.

6. Tag and disconnect the electrical cables and components that are routed through and mounted on the mast.

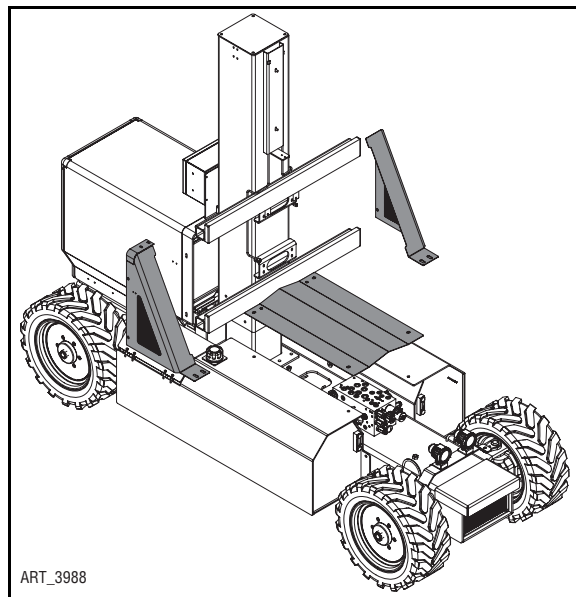

7. Remove the mast top plate and the mast front plate.
8. Tag, disconnect and remove the hydraulic hard lines at the front of the mast.

NOTE: Immediately cap and plug all openings.

9. Disconnect the hydraulic hoses inside the mast from the fittings attached to the outer mast.

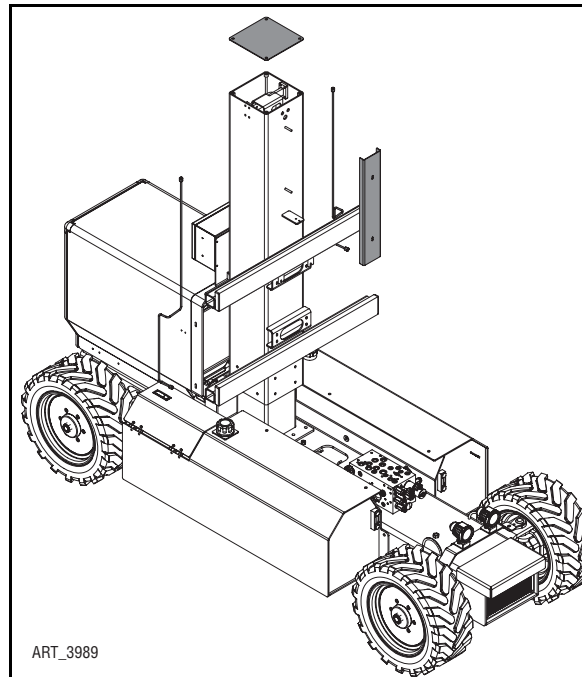

10. Remove the hose/cable bracket.
11. Disconnect the cable track (not shown) from the bottom of the hose/cable bracket.

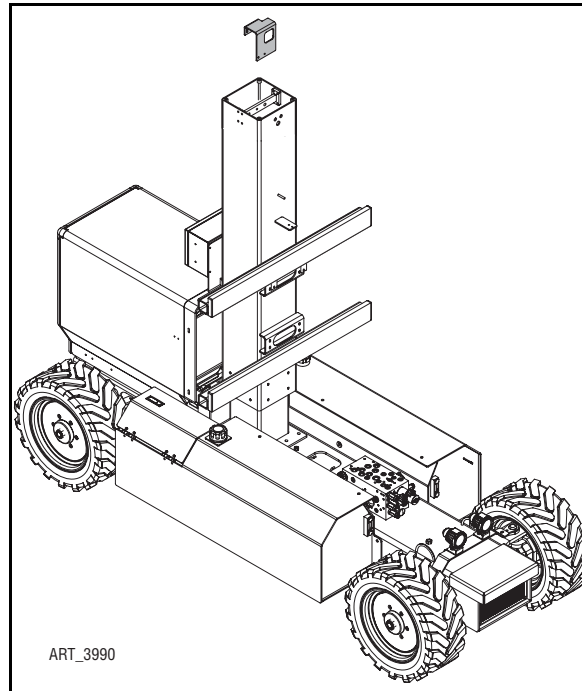

12. Remove the clevis pin that attaches the lift cylinder to the mast top bar. Remove the mast top bar.

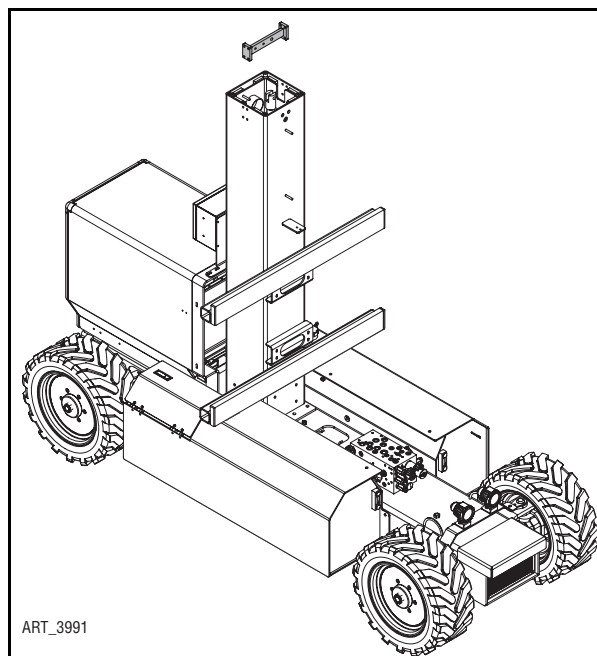

13. Replace the clevis in the top of the lift cylinder. Connect an overhead crane or appropriate lifting device to the lift cylinder and apply slight lifting tension.
14. Remove the snap ring that secures the cylinder base to the base of the mast.
15. Carefully raise the lift cylinder out of the mast.
16. Disconnect the cable track from the inner mast, then carefully remove the hoses and cables from the mast.

NOTE: If replacing hoses or cables, note the position of each within the cable track and position the replacement similarly.

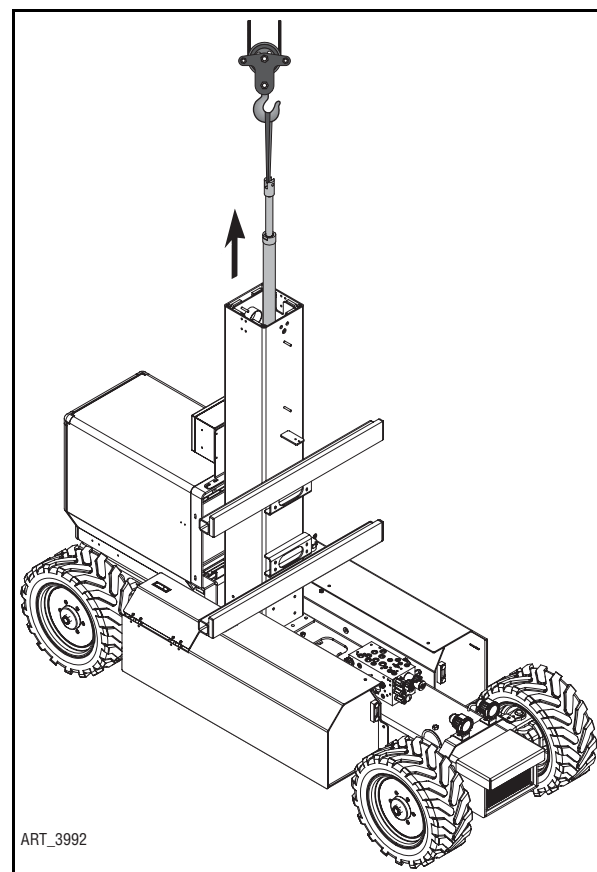

17. Replace the mast top bar, using all eight mounting bolts. Connect an overhead crane or appropriate lifting device to the mast top bar and lift the outer mast approximately 2 feet.
18. Remove the bolts that hold the lower wear pads to the inside of the outer mast. Remove the wear pads.
19. Carefully raise the outer mast off the inner mast.
20. Remove the upper wear pads from the outside of the inner mast.

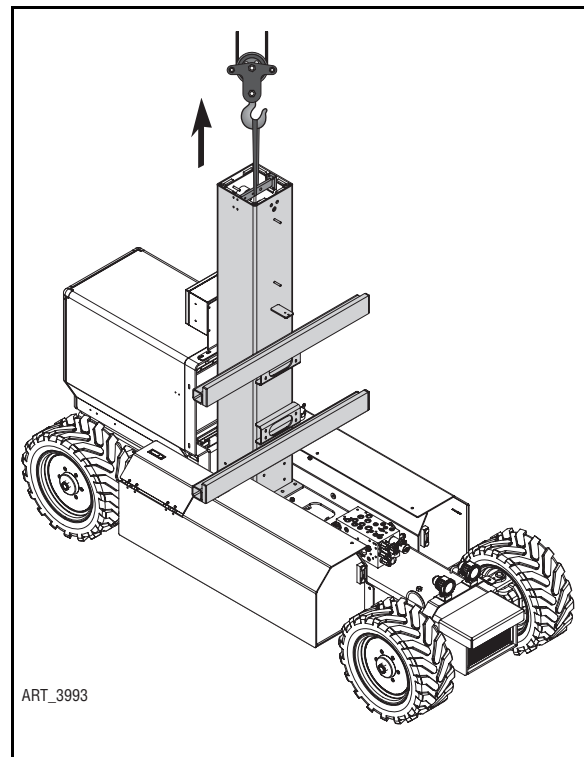

21. Connect an overhead crane or appropriate lifting device to the inner mast and apply slight lifting tension.
22. Remove the 34 bolts holding the inner mast to the chassis and mast bottom mounting plate.
23. Carefully lift the inner mast out of the chassis.

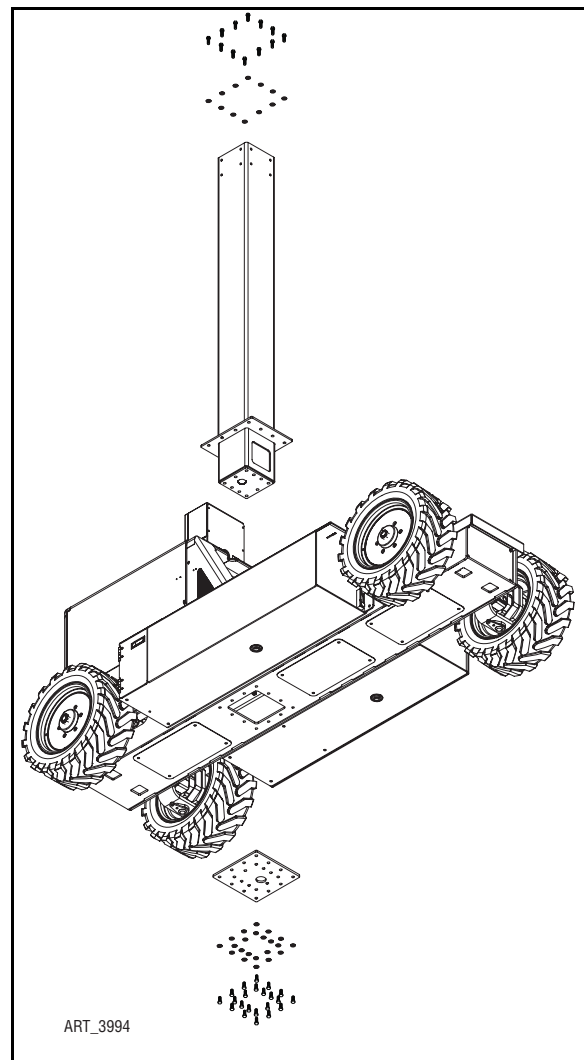

ASSEMBLY

Use Loctite 242 or equivalent on all bolts during assembly.

See chart in the Introduction section of this manual for torque specifications.

1. Install the inner mast.
 - Connect an overhead crane or appropriate lifting device to the inner mast.
 - Carefully lift the inner mast over the chassis and lower into position.

NOTE: The opening at the base of the inner mast should face the front of the machine, away from the engine.

- Install the 34 bolts holding the inner mast to the chassis and mast bottom mounting plate.
- Disconnect the inner mast from the lifting device.

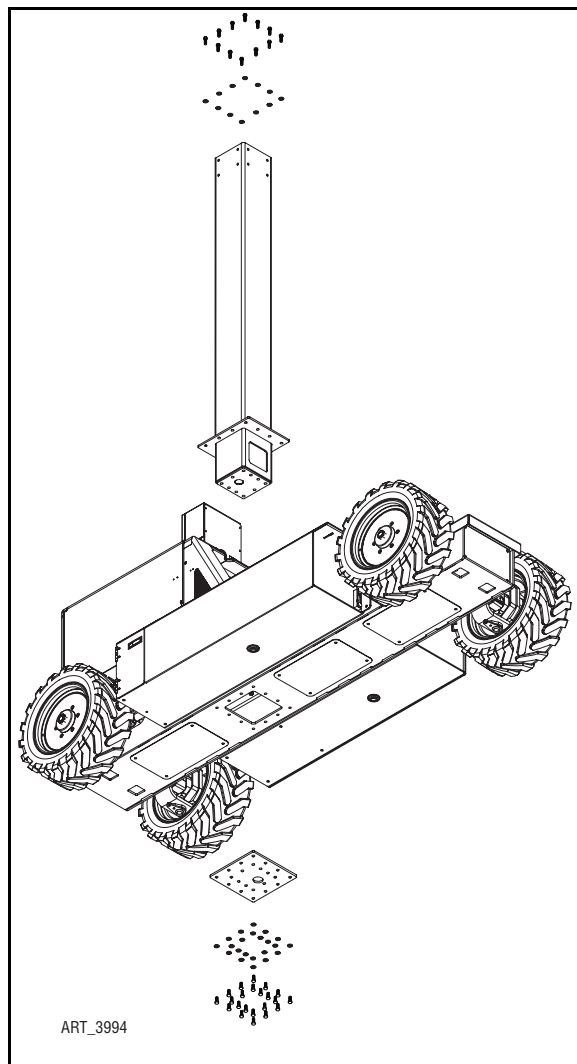

2. Install the upper wear pads onto the inner mast.

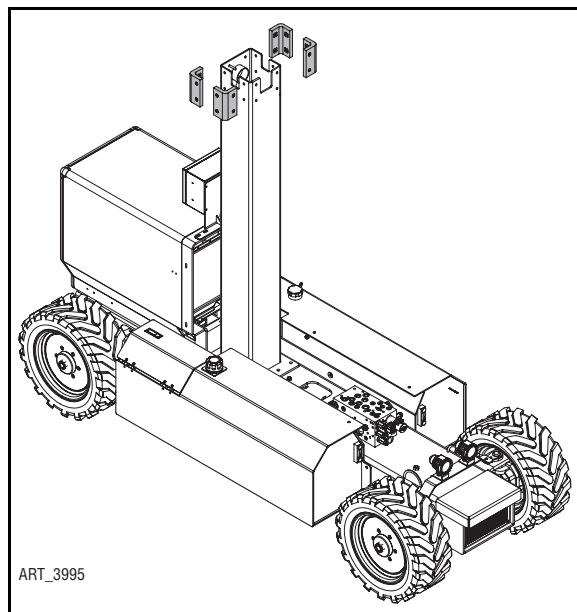

3. Install the outer mast.

- Replace the mast top bar, using all eight mounting bolts.
- Connect an overhead crane or appropriate lifting device to the mast top bar and carefully position the outer mast over the inner mast.

NOTE: The platform side shift rails on the outer mast should face the front of the machine, away from the engine.

- Carefully lower the outer mast onto the inner mast. Stop when the outer mast is approximately 2 feet from the bottom.
4. Install the lower wear pads on the inside of the outer mast.
 5. Lower the outer mast completely, then disconnect the outer mast from the lifting device.
 6. Remove the mast top bar.

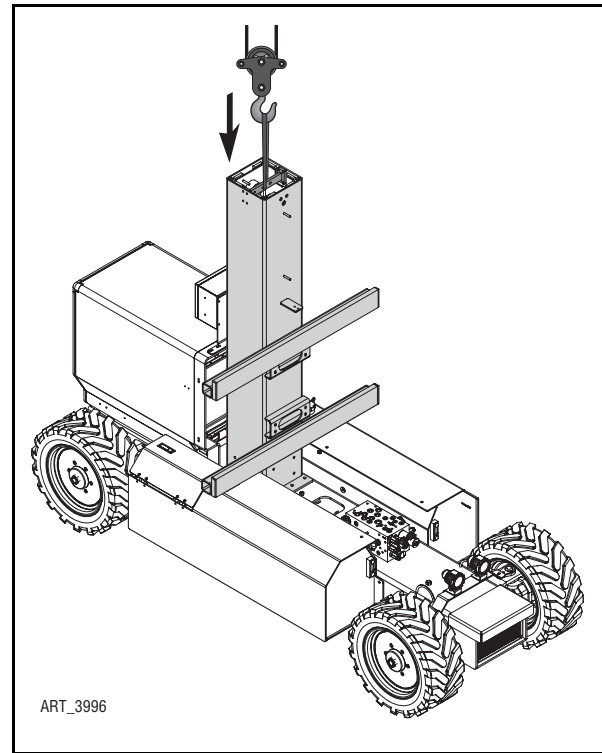

7. Install the two platform side shift hoses and the two electrical cables:

- Tape the chassis-ends of the two hydraulic hoses and the two electrical cables together and feed them down the channel in the corner of the inner mast.
- Untape the ends and pull the ends to their approximate connection locations. Do not connect at this time.
- Feed the upper ends of the hoses and cables into the cable track to the points marked in disassembly (see step 16 of the Lift Cylinder & Mast Disassembly procedure).
- Bend the cable track and fit it into the inner mast.
- Attach the cable track to the rear side of the inner mast.
- Do not connect the upper end of the hoses, cables or cable track at this point.

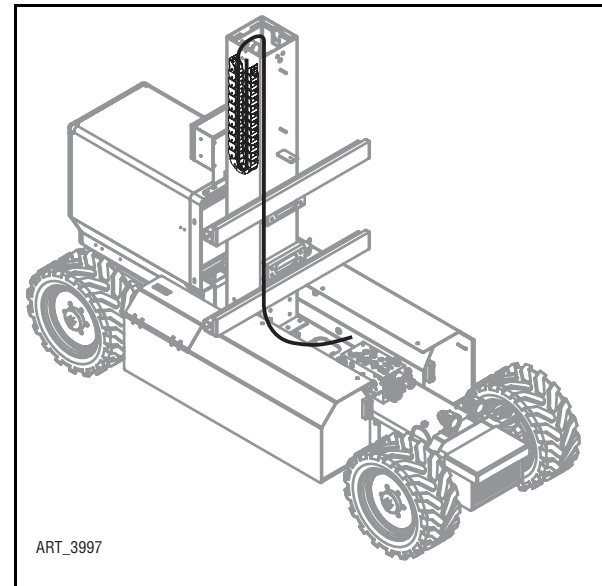

8. Install the lift cylinder.

- Replace the clevis in the top of the lift cylinder.
- Connect an overhead crane or appropriate lifting device to the lift cylinder and carefully position the lift cylinder over the mast.
- Lower the lift cylinder into mast.

NOTE: The valve and hose connection on the lift cylinder should face the front of the machine, away from the engine.

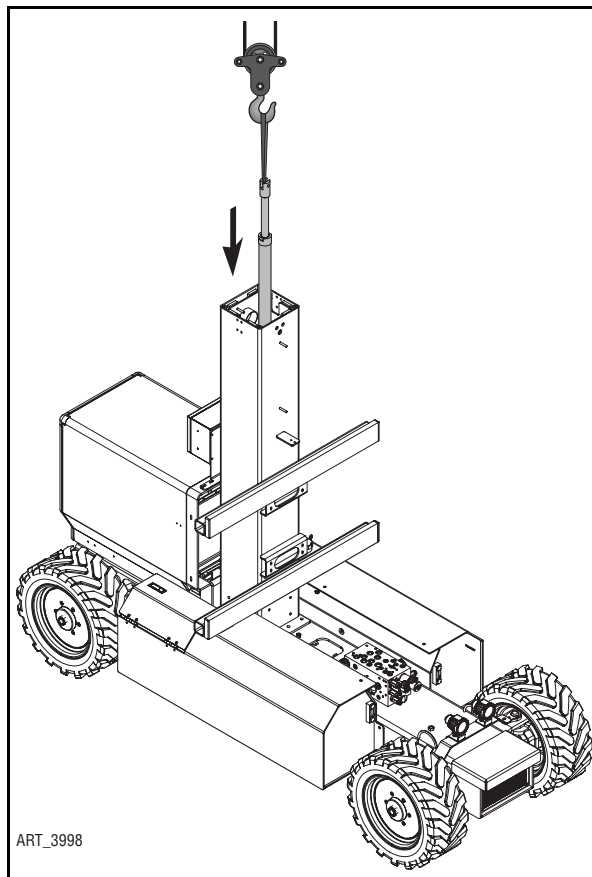

- The bottom end of cylinder fits into a recessed hole in the base of the mast. Set the positioning tab as shown, pointed toward the side of the machine.

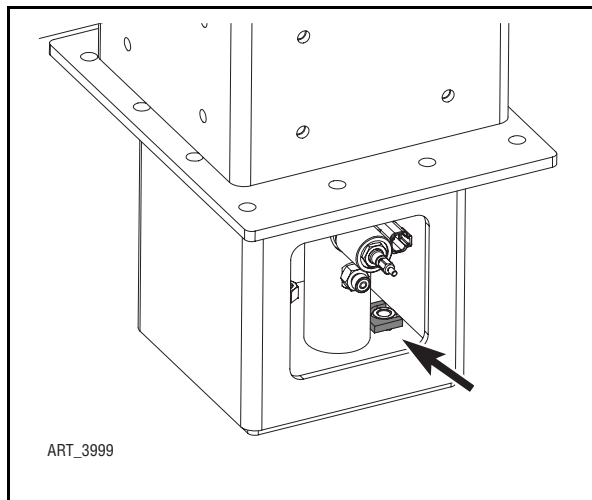

- Install the snap ring on the base of the lift cylinder.

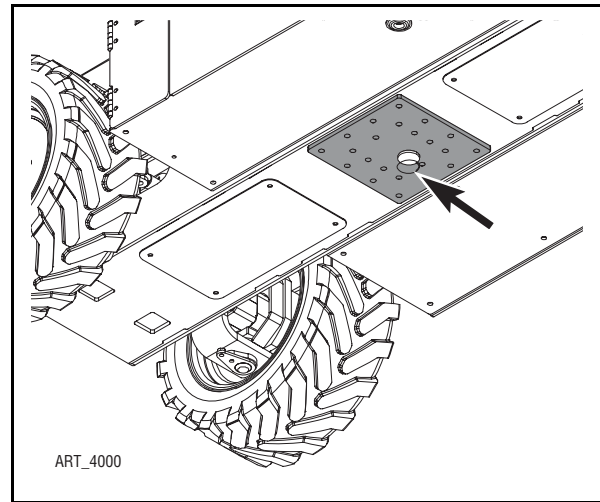

9. Install the mast top bar.

- Position the mast top bar with the lift cylinder end in place.
- Bolt the mast top bar in place.
- Install the clevis pin that attaches the lift cylinder to the mast top bar.

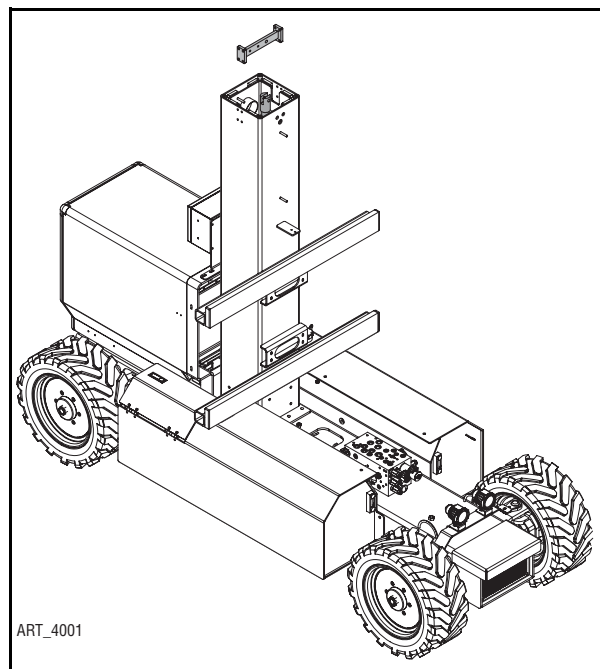

10. Pull the cable track up and attach it to the hose/cable bracket.
11. Install the hose/cable bracket onto the mast top bar.
12. Reconnect all hoses and fittings to the front surface of the outer mast.

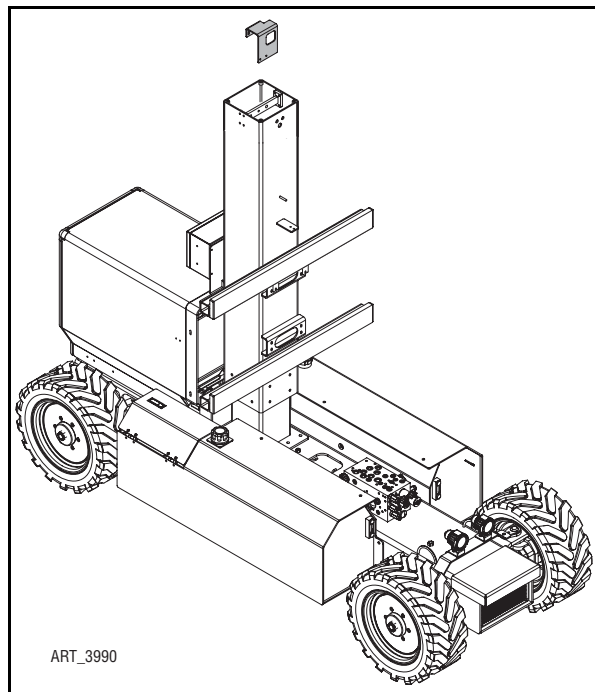

13. Re-attach and reconnect the hydraulic hard lines at the front of the mast.
14. Replace the mast top plate and the mast front plate.

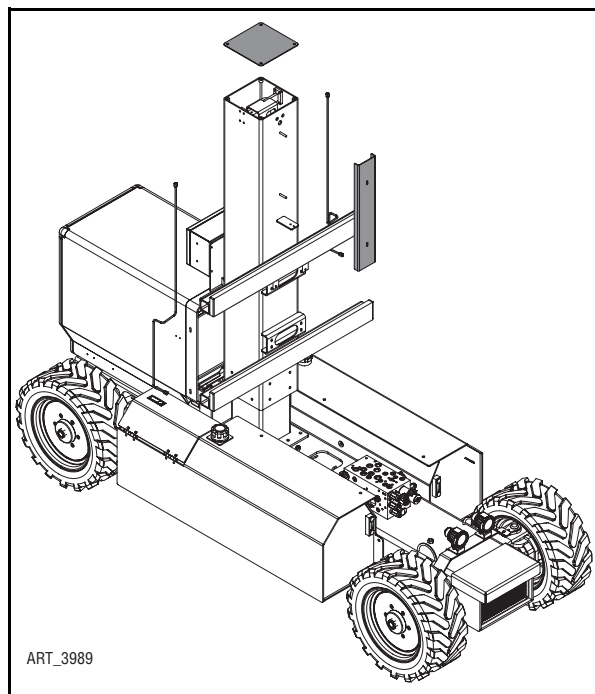

15. Reconnect the chassis ends of the electrical cables and components that are routed through and mounted on the mast.
16. Reconnect the chassis end of the platform side shift hydraulic hoses that are routed through the mast.
17. Reconnect the hydraulic hose connected to the base of the lift cylinder.
18. Replace the center access cover on the bottom of the machine.
19. Replace the machine base cover and engine side covers.
20. Replace the platform (see "Platform" on page 3-11.).

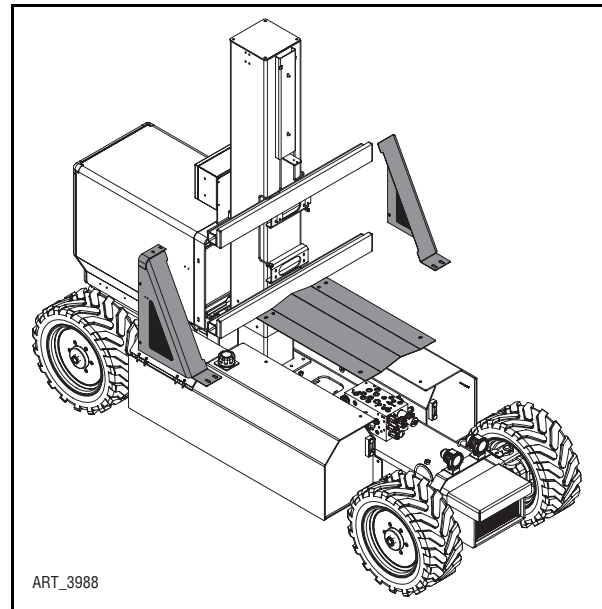

LUBRICATION

Figure 3-14: Lubrication Points

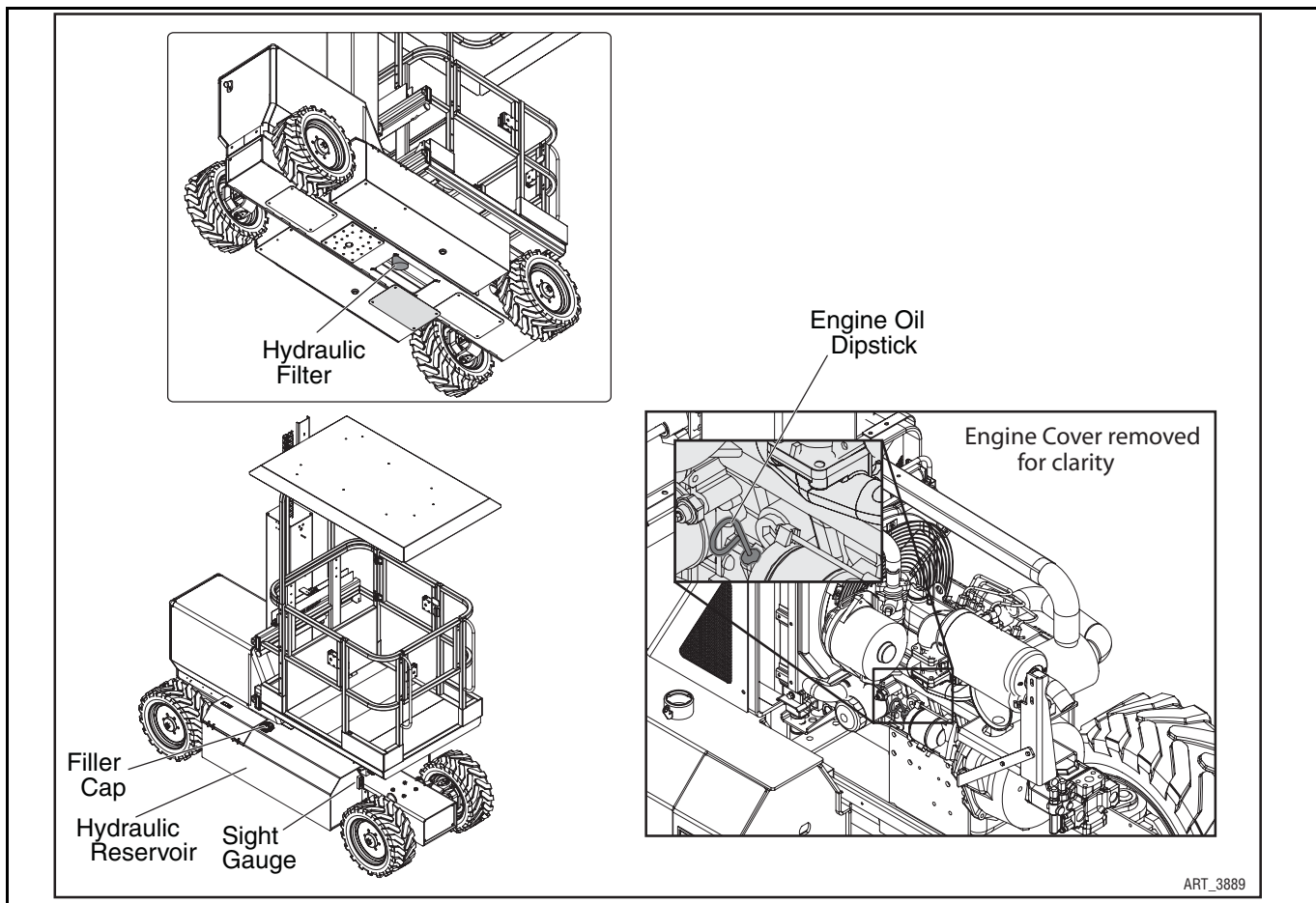

No.	ITEM	SPECIFICATION
1	Hydraulic Reservoir	Fluid Type Mobile 424 Mobile DTE13M Mobile DTE11M Temperature Range > 30° F (0° C) 0° F (-18° C) ~ 30° F (0° C) < 0° F (-18° C)
<p>DO NOT substitute other fluids as pump damage may result. Fill to the middle of the sight gauge with platform in the stowed position.</p>		
2	Hydraulic Filter Element (located inside the chassis and accessed from underneath)	<p style="text-align: center;">Scheduled Maintenance</p> <p>Normal Conditions Change every six months or 300 hours, whichever occurs first</p> <p>Severe Conditions--very dusty, exceptionally hot or cold conditions Change every three months or 150 hours, whichever occurs first</p>
3	Engine Oil IMPORTANT -- Change oil and filter after the first 50 hours of service. For complete service information consult the engine manual that came with the machine.	<p>Routine Maintenance Check oil level daily. Dipstick should read FULL. Add 10w-30 motor oil (API rating of CF or higher) as needed.</p> <p>Normal Conditions Change engine oil every 200 hours. Change oil filter every 400 hours.</p> <p>Severe Conditions--very dusty, exceptionally hot or cold conditions Change engine oil and oil filter every 200 hours.</p>

ENGINE MAINTENANCE

For complete service information consult the engine manual that came with the machine.



CAUTION

**Always wear protective eye-wear when working with fuel and oil.
Engine should be OFF when replacing filter elements.**

Figure 3-15: Engine

OIL AND OIL FILTER

Dispose of used oil and filters properly.

1. Use a suitable container to catch drained oil. Place the end of the oil drain hose into the container and open the oil drain valve. After oil has drained, close the oil drain valve.
2. Remove the old filter and wipe the filter seal contact surface with a clean towel. Coat the seal on the new filter with clean oil, then install and tighten by hand.
3. Fill engine with 10w-30 motor oil until the dipstick indicates FULL. Capacity is 5.4 US quarts (5,1 l).
4. Recheck dipstick after running engine. Fill as necessary.

AIR FILTER ELEMENT

1. Remove the wing-bolt
2. Remove old filter and replace with a new filter.
3. Replace and tighten the wing-bolt. ***Do not run the engine with the air filter element removed.***

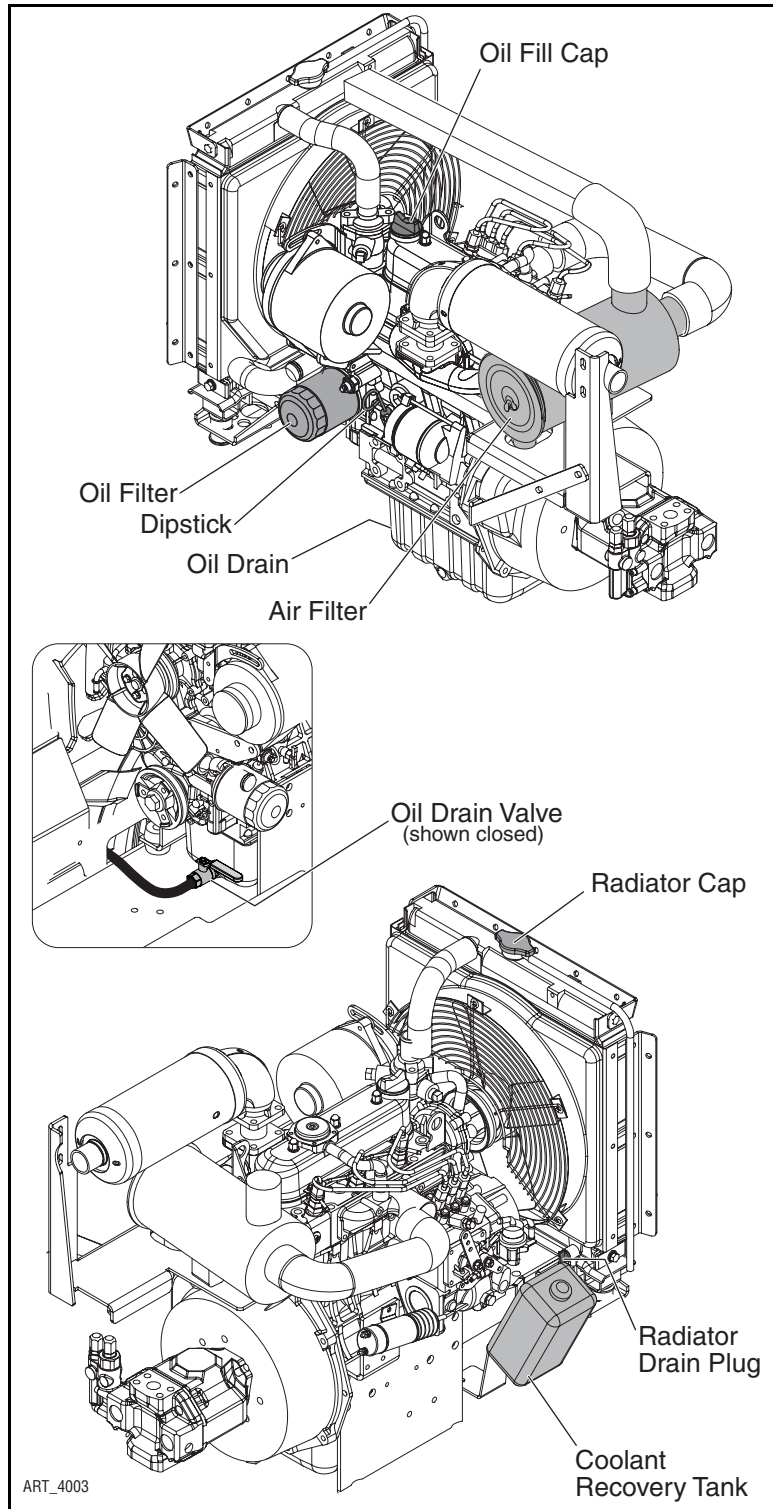

FUEL FILTER

The Fuel Filter is mounted between the radiator and the engine.

1. Turn OFF valve on bottom of fuel tank.
2. Place a suitable container beneath the fuel filter assembly to catch spilled fuel. Clean the filter area.
3. Turn filter cartridge $\frac{1}{4}$ counterclockwise remove. Wipe the filter seal contact surface with a clean towel and install a new filter.
4. Open valve at fuel tank and check for leaks.
5. Purge the air from the fuel system as follows;
 - Fill fuel tank to the fullest extent. Open valve on bottom of fuel tank.
 - Loosen bleed screw on top of fuel filter housing a few turns.
 - Close the bleed screw when there are no more bubbles.
 - Open the bleed screw on the fuel injector pump. Use the lift pump hand lever to pump fuel to the injectors. Close the bleed screw when there are no more bubbles.

NOTE: Do not attempt to start the engine until Step 5 has been performed.

6. If fuel becomes contaminated with water, use the Water Separator Valve at the bottom of the fuel cartridge to drain water.

IDLE SPEED ADJUSTMENT

1. Bring engine to operating temperature.
2. Slow engine to complete idle.
3. Adjust the Idle Stop Screw until the RPM is 950. Adjust slightly up or down to avoid vibrations.
4. Hold the Idle Stop Screw while tightening the jam nut to prevent change in adjustment.

HIGH SPEED ADJUSTMENT

IMPORTANT: – In order to prevent electrical system damage, check the Throttle Solenoid Adjustment after this procedure.

1. Bring engine to operating temperature.
2. Disconnect the Throttle Solenoid linkage at the clevis.
3. Manually pull the Throttle Lever until it contacts the High Speed Stop Screw.
4. Adjust the High Speed Stop Screw until the RPM is 3000 with the Throttle Lever against the High Speed Stop Screw.
5. Turn off the engine and reconnect the Throttle Solenoid linkage at the clevis.

Figure 3-16: Diesel Engine Fuel Filter

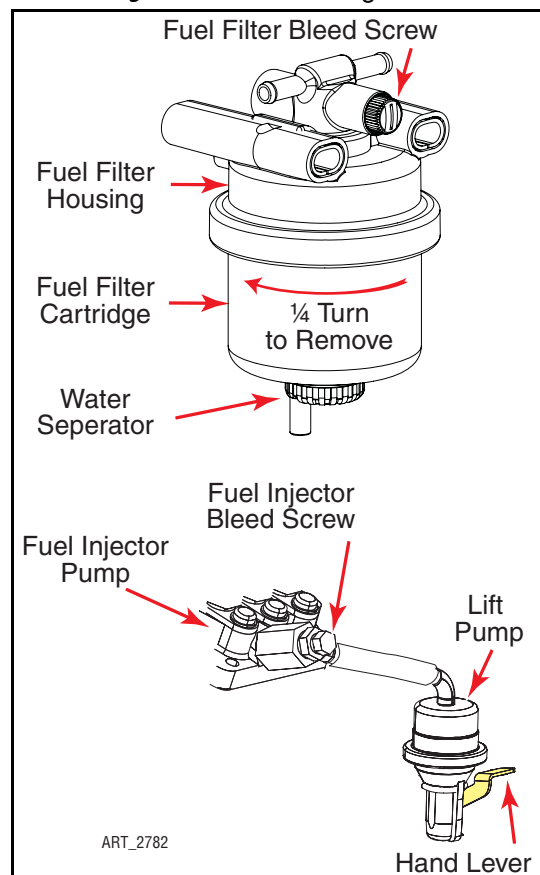

6. Hold the High Speed Stop Screw while tightening the jam nut to prevent change in adjustment.

THROTTLE SOLENOID ADJUSTMENT

IMPORTANT: – This final adjustment must be made after all other throttle speed adjustments. The solenoid must be free to retract fully in order to turn OFF the High Amperage Pull Circuit. Improper adjustment will result in solenoid failure and may damage the electrical system.

1. With the engine OFF, manually retract the solenoid by grasping the piston, just ahead of the boot, and pull to the fully retracted position.

NOTE: The solenoid must retract and extend smoothly. If movement is impaired it may be necessary to reposition the solenoid to improvement alignment.

2. With the solenoid piston fully retracted measure the distance between the High Speed Stop Screw and the Throttle linkage using a .020 feeler gauge.
3. Adjust clearance at the Throttle Solenoid linkage only.
 - Do not adjust the High Speed Stop Screw.
 - Disconnect the linkage at the clevis and turn the clevis to lengthen or shorten as necessary.
 - Reconnect the clevis and measure again. Repeat until the measurement is correct.

Figure 3-17: Diesel Engine Throttle Adjustments

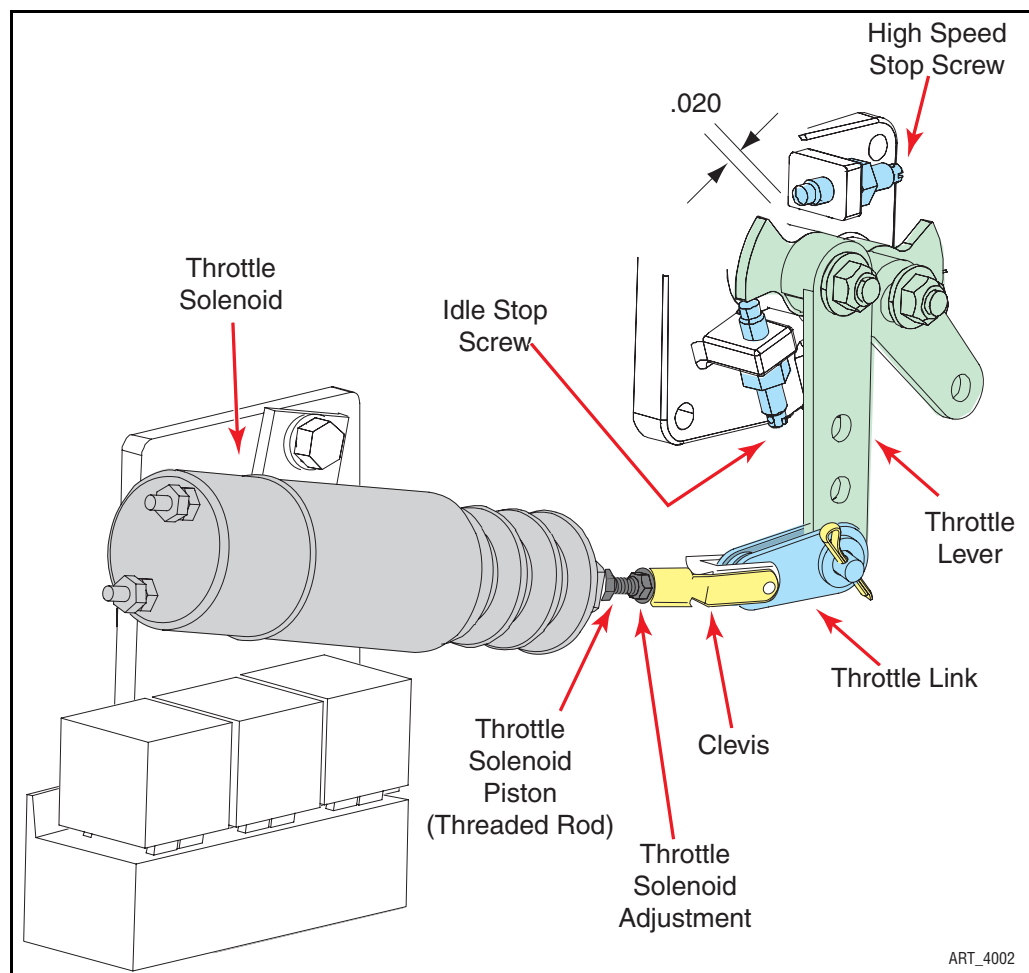



Section 4

TROUBLESHOOTING

CONTENTS

PAGE

General Troubleshooting Tips	4-3
Electrical System Troubleshooting	4-4
GP400 Module	4-5
Matrix Module	4-6
Terminal Block Module (TBM)	4-6
EZ-Cal Scan Tool	4-7
EZ-Cal Adjustments	4-11
EZ-Cal Setup	4-13
EZ-Cal Diagnostics	4-14
Ez-Cal Retrieve Mode And Help Messages	4-18
MODE Messages	4-18
Troubleshooting Chart	4-28

FIGURES

PAGE

GP400 Module	4-5
Matrix Module	4-6
Terminal Block Module (TBM)	4-6
EZ-Cal Scan Tool Connections - GP400 Module	4-7
EZ-Cal Display Example	4-8
EZ-Cal Flow Chart: Adjustments and Setup	4-9
EZ-Cal Flow Chart: Diagnostic	4-10



TABLES**PAGE**

EZ-Cal Adjustments	4-11
EZ-Cal Setup Table	4-13
EZ-Cal Diagnostics Menu	4-14
Troubleshooting Chart	4-28

GENERAL TROUBLESHOOTING TIPS

HYDRAULIC FLUID PUMP

The Hydraulic Pump used in this model is a variable displacement, pressure compensated, piston type pump. Proper adjustment is critical for normal operation of the machine. Refer to Section 1 of this manual for pressure adjustment instructions.

Common Causes of Electrical System Malfunctions:

- Battery connections are loose or corroded
- Battery is not fully charged.
- Emergency Stop buttons are pushed (OFF position).
- Circuit breaker is in the tripped (OFF position).

Common Causes of Hydraulic System Malfunctions:

- Hydraulic fluid level is too low.
- Incompatible hydraulic fluids mixed, destroying the additives and causing varnish build-up, resulting in the valves sticking.
- Water in the hydraulic fluid due to a damp climate.
- Improper hydraulic fluid used. Viscosity too high in cold climates. Viscosity too low in warm climates.
- Hydraulic fluid contaminated with debris - filter change interval neglected.

NOTE: MEC uses a multiple viscosity fluid that is light enough for cold climates and resists thinning in warm climates. Use only the recommended hydraulic fluid. Substituting with a lower grade fluid will result in pump failure. Refer to Section 1 of this manual.

NOTE: Contamination always causes failure in any hydraulic system. It is very important to be careful not to introduce any contamination into hydraulic system during the assembly procedures. Please make sure all ports and cavities of the manifold and cylinders are properly capped or plugged during maintenance activities.

ELECTRICAL SYSTEM TROUBLESHOOTING

The electronic control system used on this machine was designed for low maintenance and long trouble free operation. The system consists of two microprocessor modules: the Matrix Module and the GP400 Processor. They communicate through a low voltage digital signal called Can-Bus communication.

To protect against part failure or incorrect plug connections, the modules are fully protected against short circuit and reverse polarity. All electrical plug connections are waterproof to promote longer trouble free operation and to increase terminal life.



NEVER ATTEMPT TO SUPPLY BATTERY POWER, OR VOLTAGE HIGHER THAN 12 VOLTS TO ANY PART OR MODULE IN THIS SYSTEM, AS CATASTROPHIC FAILURE OF THE MODULES MAY RESULT.

USE OF HIGH PRESSURE WASHING EQUIPMENT DIRECTLY ON THE MODULES CAN FORCE WATER INTO SEALED CONNECTION AND CAN CAUSE A TEMPORARY SYSTEM SHUT-DOWN. HIGH PRESSURE WASHING IN THE VICINITY OF THE MODULES IS HIGHLY DISCOURAGED.

GP400 MODULE

The GP400 module is “the brains” of the system. It receives and processes a variety of inputs both from the machine and the operator, then controls all the operative functions of the machine. It also has a feature that allows the technician to access and monitor all functionality of the system, along with a technician-friendly series of fault messages that can be accessed through the use of the EZ-Cal scan tool. Flash codes are also provided in case an EZ-Cal scan tool is not available.

Such information can be used for preventative maintenance and troubleshooting should a problem arise. A comprehensive list of EZ-Cal accessible information can be found later in this section.

The GP400 operates on 12 volts DC and should never be probed or operated with voltage higher than 14 volts DC

Figure 4-1: GP400 Module

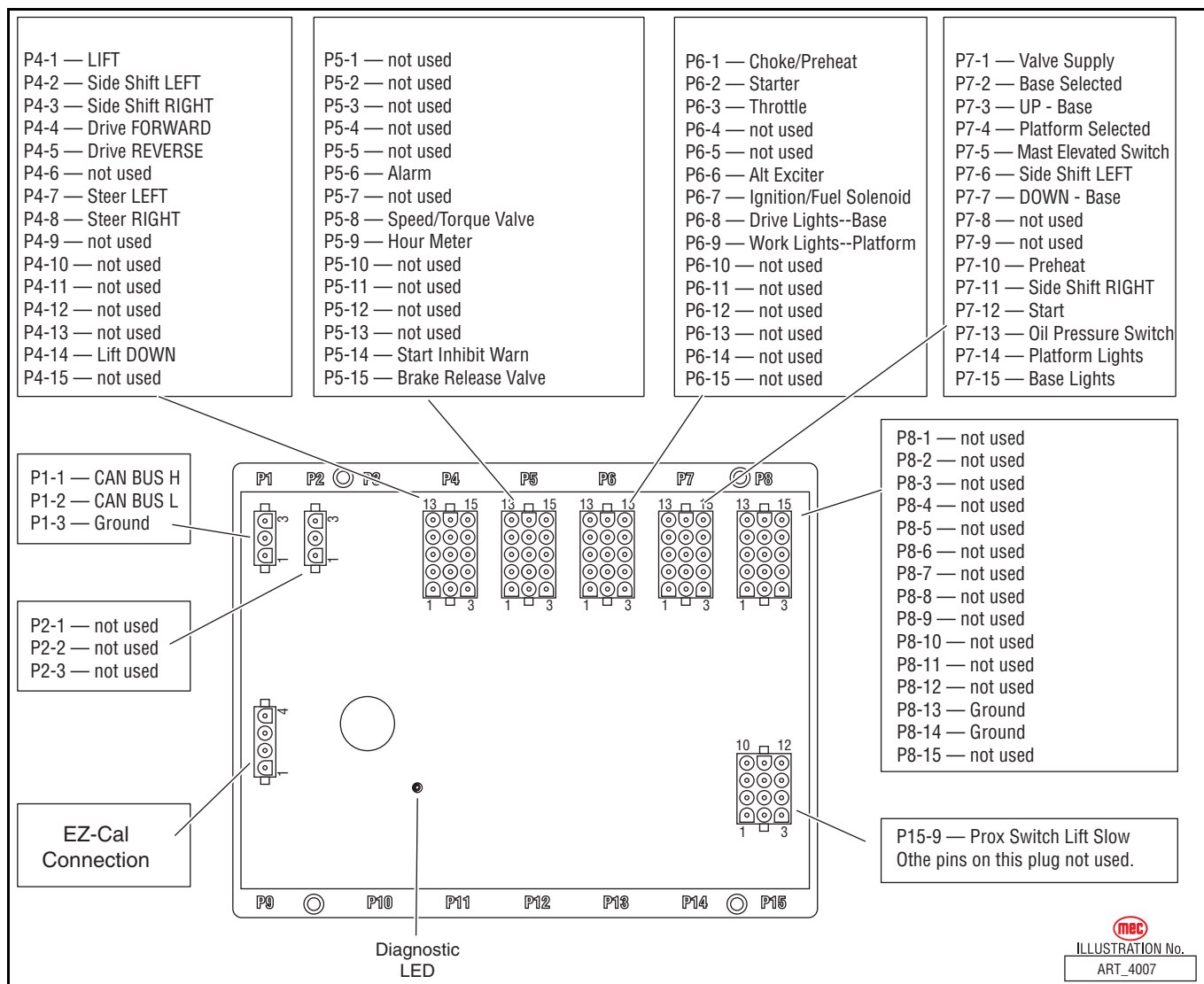

MBC
 ILLUSTRATION No.
 ART_4007

MATRIX MODULE

The Matrix Module is the remote module located inside the upper control box. It received inputs from the operator and relays them to the GP400.

Figure 4-2: Matrix Module

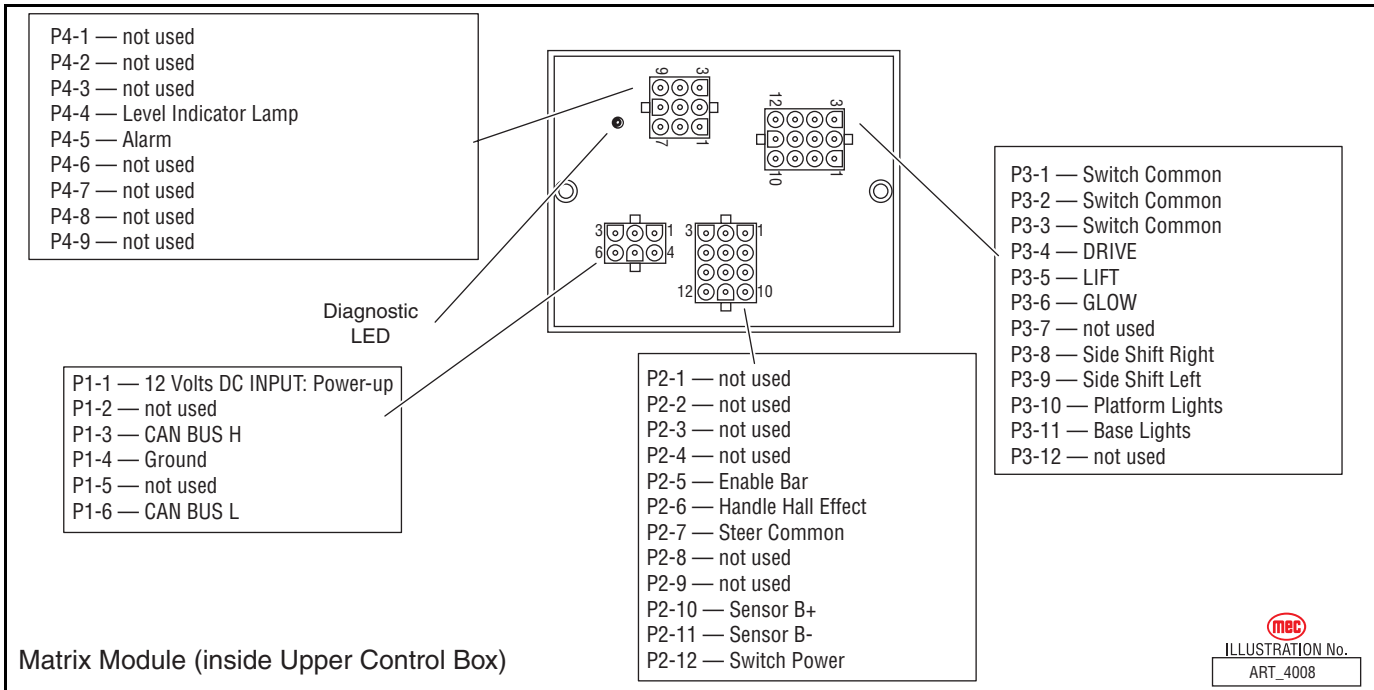

TERMINAL BLOCK MODULE (TBM)

The Terminal Block Module (TBM) is a module located inside the lower control box that provides terminal point connections for both positive and ground circuits. A signal from the Emergency Stop circuit activates a load-reduction relay within the TBM that provides power to the B+ (positive) terminal strip. This arrangement protects the system against voltage drop conditions that can be detrimental to the electrical system.

Figure 4-3: Terminal Block Module (TBM)

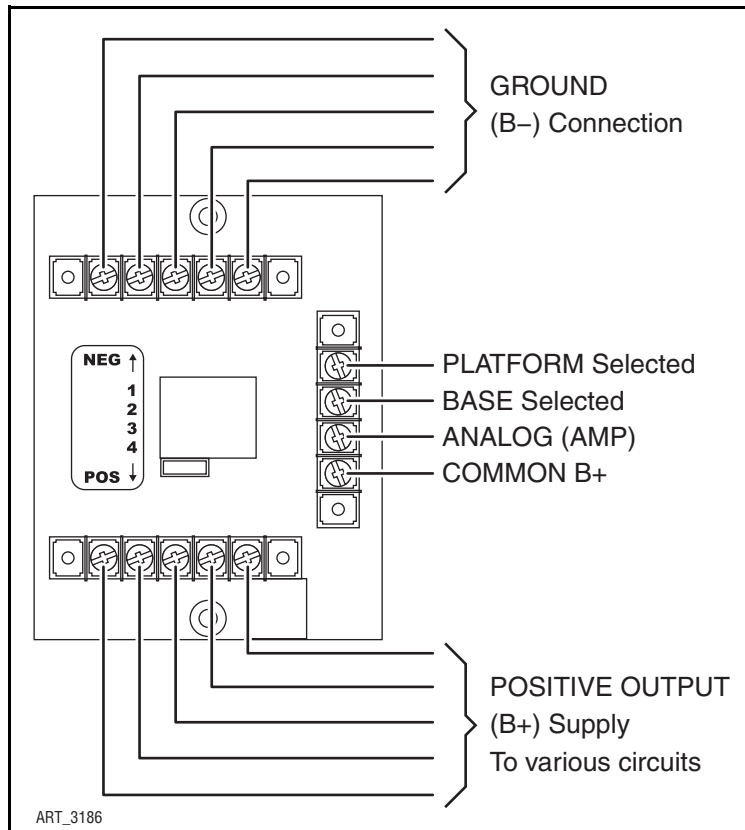

EZ-CAL SCAN TOOL

The EZ-Cal (MEC part # 90888; not part of the machine) is a hand-held scan tool that interfaces with the system to provide various information and adjustments. The EZ-cal receives its power from the GP400 when connected. The system must be powered up by pulling both emergency stop switches. You must also select Base or Platform depending on the station you will operate from.

USING THE EZ-CAL SCAN TOOL

To operate the EZ-cal, plug the cable into the 4-terminal receptacle P9 on the GP400 and power the system up.

- The EZ-Cal display will illuminate and read "HELP: PRESS ENTER". From this point, use the right and left arrows to scroll through the base menus.
- Once the desired base menu is obtained (i.e. *ADJUSTMENTS*) press Enter to access sub menus.
- Use the right and left arrows to scroll through sub menus, press Enter again.
- The up/down arrows are used to change settings only.
- Press ESC to back up one level.

Figure 4-4: EZ-Cal Scan Tool Connections - GP400 Module

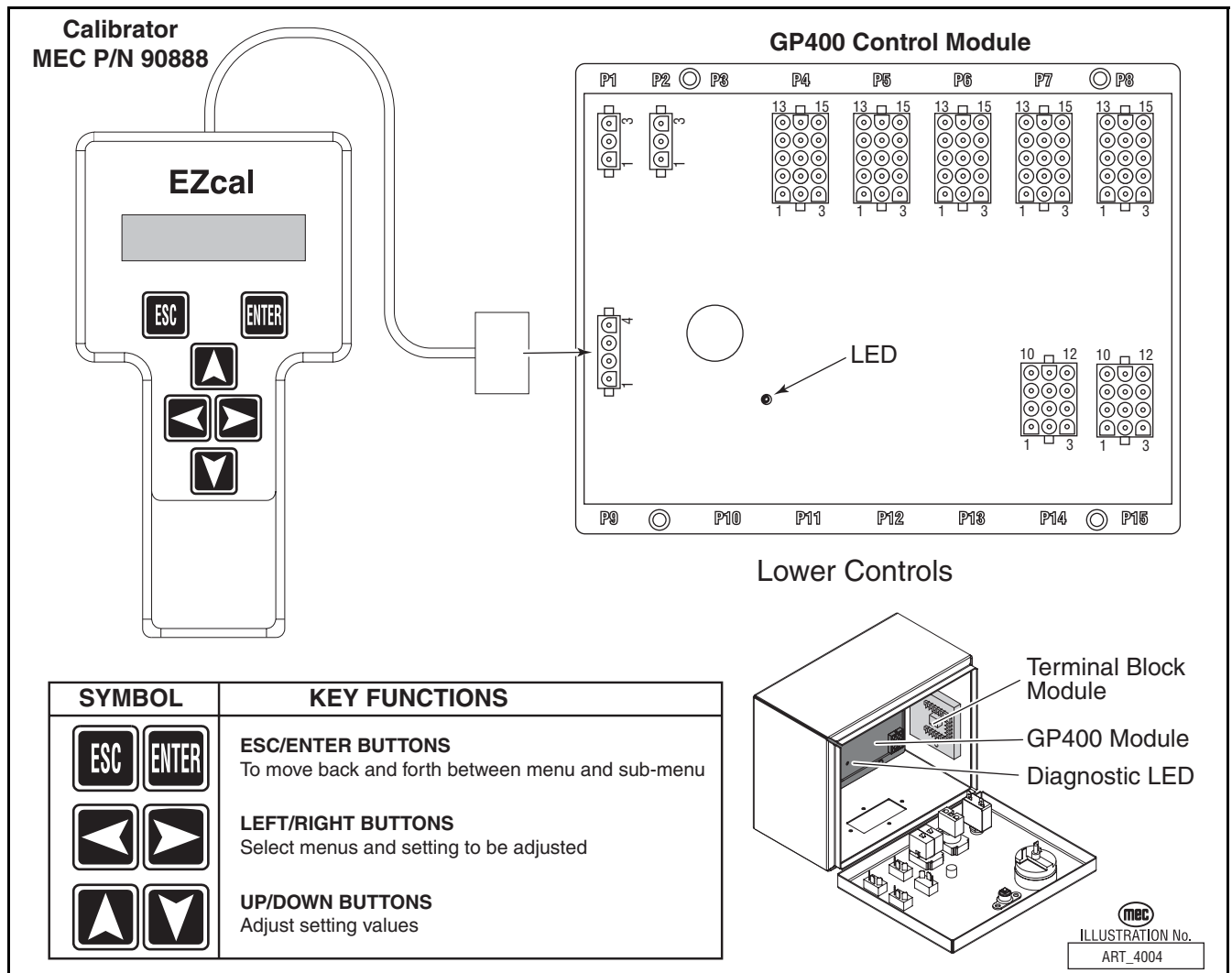

USING THE EZ-CAL WITH THE FLOW CHARTS

Use the EZ-cal Flow Charts as a guide to locate diagnostic information and make adjustments. Each box in the flow chart will have 3 bits of information.

Figure 4-5: EZ-Cal Display Example

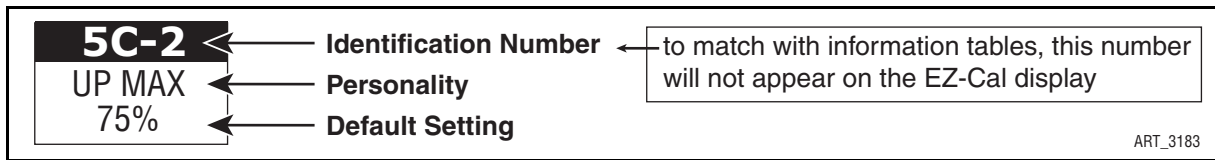

The IDENTIFIER (5c2): – Used to locate this specific personality in the informational charts. Here you can obtain specific information on the individual personalities.

The PERSONALITY (Up Max): – Identifies the individual personalities.

The DEFAULT SETTING: – The factory setting. If adjustments are made, they must be returned to default setting.



ACCESS LEVEL 1 PROVIDES ACCESS TO CHANGE PERSONALITIES NORMALLY PRESET AT THE FACTORY TO PROVIDE PROPER MACHINE MOVEMENT AT SAFE SPEEDS. PERSONALITIES MUST NOT BE CHANGED WITHOUT PRIOR AUTHORIZATION FROM MEC AND MAY ONLY BE RETURNED TO FACTORY SPECIFICATION AS LISTED IN THE FOLLOWING TABLES.

ERROR MESSAGES

To obtain error messages from the EZ-cal Connect the EZ-cal as mentioned above. The display will read, "HELP:PRESS ENTER". Press Enter to display the current error message. Use the following list of error messages to better understand the fault. Pressing Enter twice will provide a scrolling message of the current error followed by a log of previous errors that may have occurred within recent operation.

SCROLLING MESSAGES

The EZ-Cal will provide a scrolling message of the current error followed by a log of previous errors that may have occurred within recent operation. Refer to "Scrolling Message" on page 4-18.

FLASH CODES

Flash Codes, provided from the GP400 red LED, will also assist in the event an EZ-cal is not available. However, the EZ-cal yields considerably more relevant information. Refer to "EZ-Cal HELP Messages" on page 4-21 for flash coded error messages.

Figure 4-6: EZ-Cal Flow Chart: Adjustments and Setup

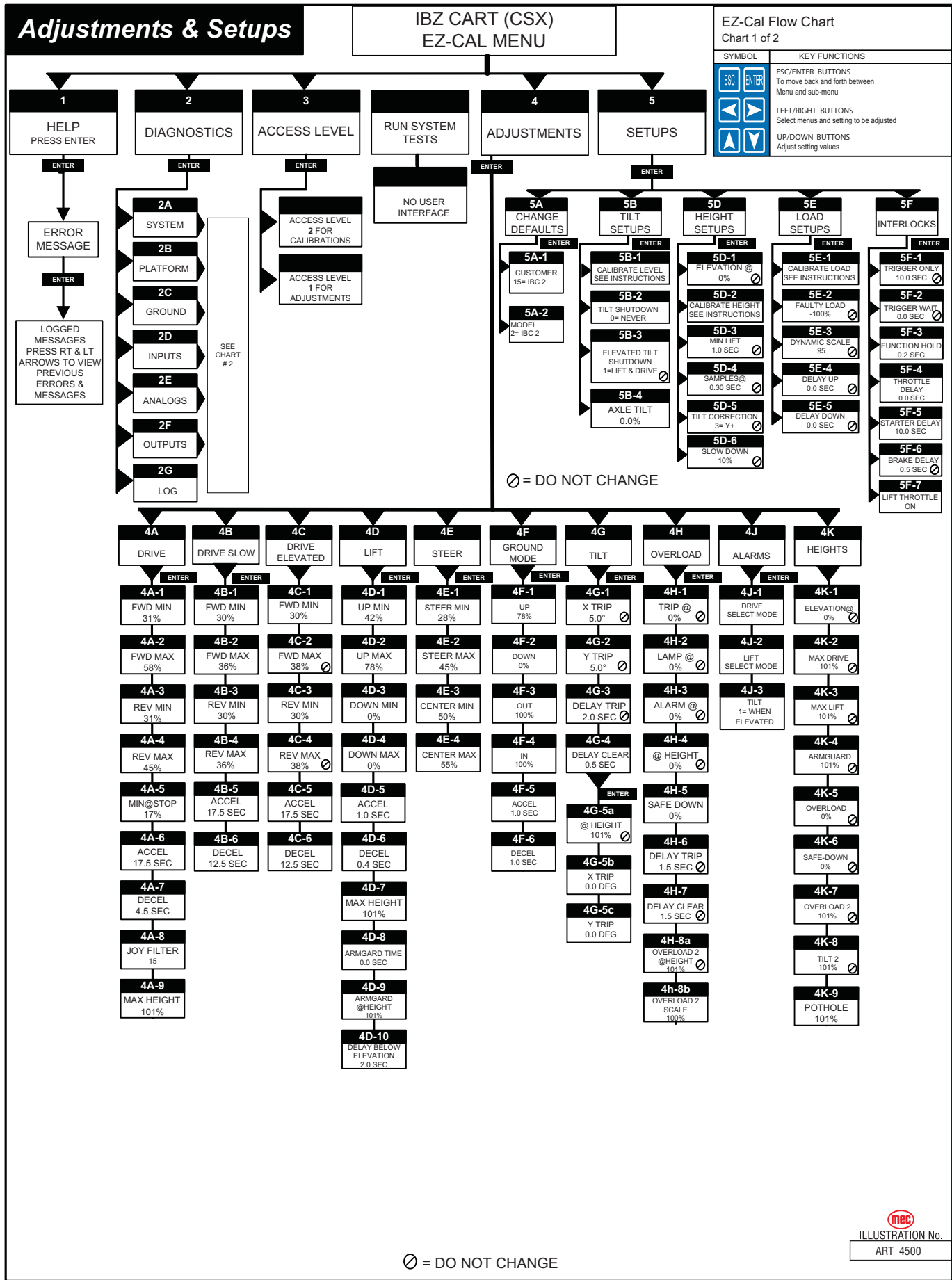

⊖ = DO NOT CHANGE

ILLUSTRATION No.
ART_4500



Figure 4-7: EZ-Cal Flow Chart: Diagnostic

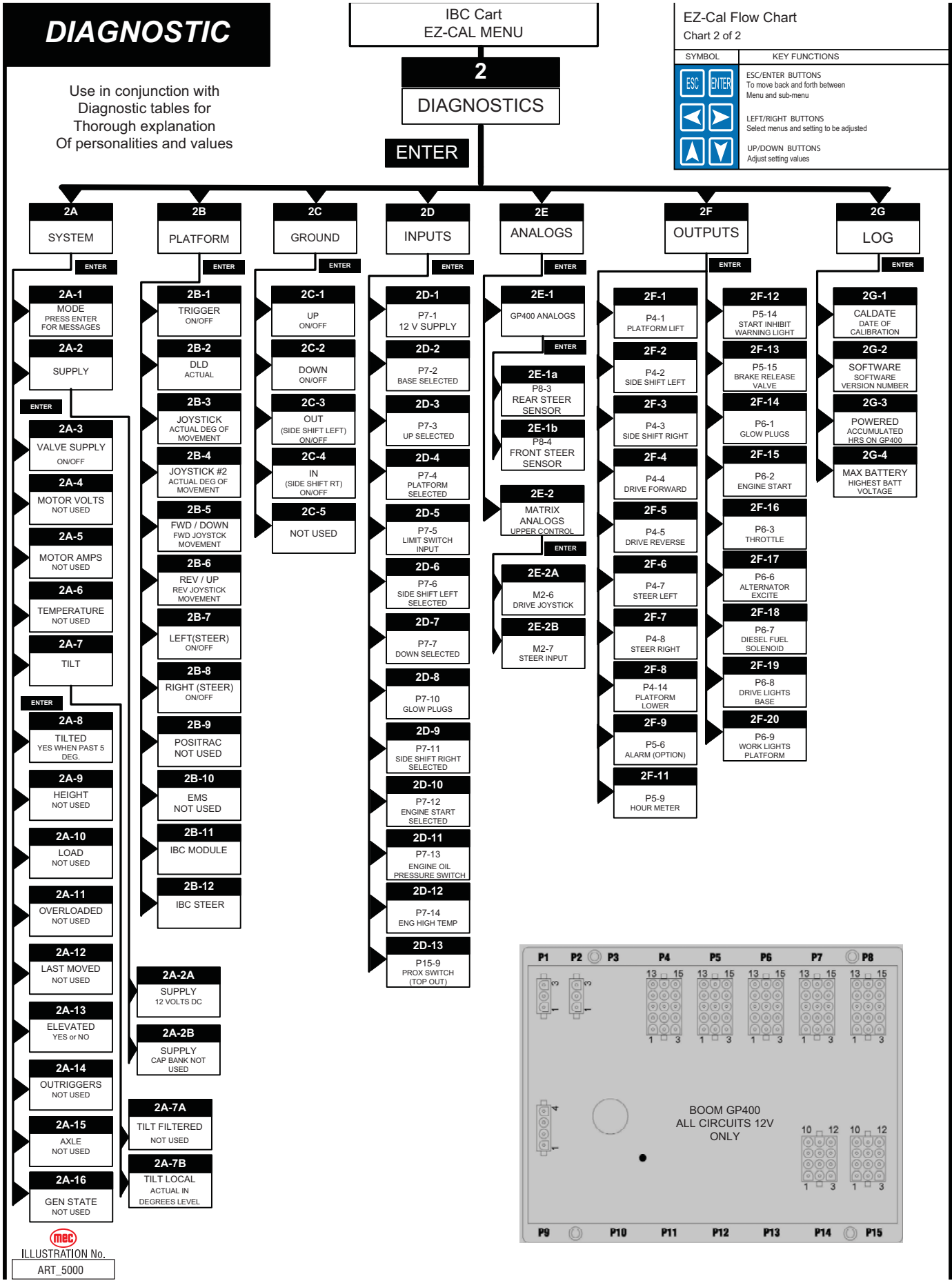

EZ-CAL ADJUSTMENTS

Refer to "Using the EZ-cal Scan Tool" on page 4-7.

Adjustments possible in Access Level 1 Only.

Before changing personalities, ensure that the correct customer and model have been selected in the SETUPS menu. Any changes to settings will be lost when the model or customer is changed.

To reach ADJUSTMENTS, first access Level 1, then press --> for ADJUSTMENTS.

Press Enter, then press --> to scroll through the sub-menus.

Once the desired sub-menu is found, press Enter again, then --> to scroll through the personalities. Press the Up or Down arrows to change the personality. Press ESC to go back one or more levels to reach other sub-menus.

Table 4-1: EZ-Cal Adjustments

OPERATION	ID	PERSONALITY	Factory Setting	Explanation
4A DRIVE (platform Stowed)	4A1	Fwd Min	31%	Slowest speed possible
	4A2	Fwd Max	58%	Maximum speed potential
	4A3	Rev Min	31%	Slowest speed possible
	4A4	Rev Max	45%	Maximum speed potential
	4A5	Min@stop	0%	
	4A6	Accel	17.5 sec	Ramp up time to maximum
	4A7	Decel	4.5 sec	Ramp down to stop
	4A8	Joy Filter	15	
	4A9	Max Height	101%	Maximum drivable height
4B DRIVE - SLOW	4B1	Fwd Min	30%	Slowest speed possible
	4B2	Fwd Max	38%	Maximum speed potential
	4B3	Rev Min	30%	Slowest speed possible
	4B4	Rev Max	38%	Maximum speed potential
	4B5	Accel	17.5 sec	Ramp up time to maximum
	4B6	Decel	12.5 sec	Ramp down to stop
4C DRIVE - ELEVATED	4C1	Fwd Min	21%	Slowest speed possible
	4C2	Fwd Max	34%	Maximum speed potential
	4C3	Rev Min	23%	Slowest speed possible
	4C4	Rev Max	36%	Maximum speed potential
	4C5	Accel	17.5 sec	Ramp up time to maximum
	4C6	Decel	12.0 sec	Ramp down to stop
4D LIFT	4D1	Up Min	42%	Slowest speed possible
	4D2	Up Max	78%	Maximum speed potential
	4D3	Down Min	0% (not used)	Gravity down
	4D4	Down Max	0% (not used)	Gravity down
	4D5	Accel	1.0 sec	Ramp up time to maximum
	4D6	Decel	0.4 sec	Ramp down to stop
	4D7	Max Height	101%	Not used on IBC Cart
	4D8	Armguard Time	0.0 sec	Not used on IBC Cart
	4D9	Armguard @ height	1%	Not used on IBC Cart
	4D10	Delay Below Elevation	2.0 sec	

Table 4-1: EZ-Cal Adjustments

OPERATION	ID	PERSONALITY	Factory Setting	Explanation
4E STEER	4E1	Steer Min	28%	Slower speed nearing center
	4E2	Steer Max	45%	Steer speed other than center
	4E3	Center Min	50%	Steer speed while maintaining center
	4E4	Center Max	55%	Steer speed while maintaining center
4F GROUND MODE lower control operations	4F1	Up	78%	Maximum speed potential
	4F2	Down	0%	Not used - Gravity down
	4F3	Out	100%	Platform Side Shift adjustment
	4F4	In	100%	Platform Side Shift adjustment
	4F5	Accel	1.0 sec	Ramp up time to maximum
	4F6	Decel	1.0 sec	Ramp down to stop
4G TILT	4G1	X Trip	5.0 degrees	angle tilt sensor signals out of level
	4G2	Y Trip	5.0 degrees	angle tilt sensor signals out of level
	4G3	Delay Trip	1.5 sec	Time delay between tip and signal
	4G4	Delay Clear	0.5 sec	Time delay between clear tip and signal off
	4G5	Tilt # 2	0%	Not used on IBC Cart
Sub Menu	4G5a	X trip2	1.5 deg	Not used on IBC Cart
	4G5b	Y trip2	1.5 deg	Not used on IBC Cart
4H Overload Not Used on IBC Cart	4H1	Trip @	0%	Not used on IBC Cart
	4H2	Lamp @	0%	Not used on IBC Cart
	4H3	Alarm@	0%	Not used on IBC Cart
	4H4	@ Height	0%	Not used on IBC Cart
	4H5	Safe Down	0%	Not used on IBC Cart
	4H6	Delay Trip	1.5 sec	Not used on IBC Cart
	4H7	Delay Clear	1.5 sec	Not used on IBC Cart
	4H8a	Height 0%	0%	Not used on IBC Cart
	4H8b	Scale	100%	Not used on IBC Cart
4j ALARMS (Optional)	4J1	Drive yes/no	no	1=fwd, 2=rev, 3=both, 4= all motion
	4J2	Lift	2= down	1=up, 2=dwn, 3=both, 4= all motion
	4J3	Tilt	1= when elev	1= when elevated, 2= always
4k HEIGHTS Not Used on IBC Cart	4K1	Elevation @	0%	Not used on IBC Cart
	4K2	Max Drive	101%	Not used on IBC Cart
	4K3	Max Lift	101%	Not used on IBC Cart
	4K4	Armguard	101%	Not used on IBC Cart
	4K5	Overload	0%	Not used on IBC Cart
	4K6	Safe Down	0%	Not used on IBC Cart
	4K7	Overload 2	0%	Not used on IBC Cart
	4K8	Tilt # 2	101%	Not used on IBC Cart
	4K9	Pothole	101%	Not used on IBC Cart

EZ-CAL SETUP

Changes to Setups are possible in Access Level 1 only. Calibration changes are possible in access level 2. Only authorized personnel have access to, and may make changes to personalities.

Refer to "Using the EZ-cal Scan Tool" on page 4-7.



SEE "CAUTION INSTRUCTIONS" BEFORE ATTEMPTING CALIBRATIONS. INCORRECT CALIBRATION CAN CAUSE MACHINE INSTABILITY.

NOTE: Changing CUSTOMER (5A1) will clear all calibration data stored in the GP400 requiring complete recalibration.

Changing MODEL (5A2) will return all settings and Adjustments to their default value possibly causing the machine to operate differently than desired (see Adjustment Flow Charts for default values).

Table 4-2: EZ-Cal Setup Table

OPERATION	ID	PERSONALITY	FACTORY SETTING	EXPLANATION
5a CHANGE DEFAULTS	5A1	Customer	15= IBC 2	Changing this personality will cause this model to operate improperly or not operate at all
	5A2	Model	2 = IBC 2	Changing this personality will return all setting to default status possibly limiting machine operation
5b TILT SETUPS	5B1	Calibrate Level? Y=ENTER, N=ESCAPE		Pressing enter twice will calibrate level sensor
	WARNING! Refer to Tilt Sensor Calibration instructions before attempting calibration			
	5B2	Tilt Shutdown	0 = never	Function disabled when tilted (stowed)
	5B2	Elevated Tilt Shutdown	0 = Lift and Drive	DO NOT CHANGE
5d HEIGHT SETUP	5B4	Axle Tilt	0%	Not used
	5D1	Elevation @	0%	DO NOT CHANGE
	5D2	Calibrate Height? N=ESCAPE		IBC Cart not equipped with Load Sensing
	IBC Cart not equipped with load sensing system - no calibration necessary			
	5D3	Min Lift	1.0 Sec	DO NOT CHANGE
	5D4	Samples @	0.3 Sec	DO NOT SET ABOVE 98%
	5D5	Tilt Correction	3= Y+	DO NOT CHANGE
5e LOAD SETUPS (Overload Sensing Option only)	5D6	Slow Down	10%	DO NOT CHANGE
	5E1	Calibrate Load? N=ESCAPE		IBC Cart not equipped with Load Sensing
	IBC Cart NOT equipped with load sensing system - no calibration necessary			
	5E2	Faulty Load	-100%	NOT USED
	5E3	Dynamic Scale	.95	NOT USED
	5E4	Delay Trip	0.0 sec	NOT USED
5E5	Delay Down	0.0 sec	NOT USED	

Table 4-2: EZ-Cal Setup Table

OPERATION	ID	PERSONALITY	FACTORY SETTING	EXPLANATION
5f INTERLOCKS	5F1	Trigger Only	10 Seconds	DO NOT CHANGE
	5F2	Trigger Wait	0.0 Sec	DO NOT CHANGE
	5F3	Function Hold	0.2 Sec	DO NOT CHANGE
	5F4	Throttle Delay	0.0 Sec	DO NOT CHANGE
	5F5	Start Delay	10.0 Sec	Qty of time starter will operate before 30 sec cool down
	5F6	Brake Delay	0.5 Sec	Time delay before applying parking brakes
	5F7	Lift Throttle	ON	Turns throttle on in Lift mode

EZ-CAL DIAGNOSTICS

The EZ-Cal Diagnostics menu provides the ability to view and test individual circuits for irregularities. Whether diagnosing a failure or testing functions during preventative maintenance, the *Diagnostics Menu* provides a quick view at the inputs and outputs as registered by the GP400 Control Module *in real time*. Using the EZ-Cal Flow Chart, compare ID number to this menu for circuit identification and result.

To reach DIAGNOSTICS menu from HELP;

- Press the right arrow and scroll to DIAGNOSTICS and press ENTER.
- Locate the desired sub menu and press ENTER.
- Press the right arrow to scroll through the test points.

NOTE: The ID number will not appear on the EZ-Cal display. It is shown in the *Diagnostics Menu* for reference only.

Using the ID number, match specific personalities from the Diagnostic Flow Chart with this table for additional information.

Press **ESC** to go back one level (necessary to change selection).

SELECTION	ID #	EZ-cal Readout	Explanation
2a SYSTEM	2A1	MODE	Current status message/s, press ENTER for additional information
	2A2	Supply	Indicates output supply voltage from GP400 in DC volts.
	2A2a	12 v Supply	Indicates supply voltage to GP400 in DC volts.
	2A2b	Cap Bank	not used on IBC Cart
	2A3	Valve Supply	Indicates when output voltage from GP400 is On/Off
	2A4	Motor Volts	not used on IBC Cart
	2A5	Motor I	not used on IBC Cart
	2A6	Temperature	not used on IBC Cart
	2A7	Tilt	Current state of tilt as measured by GP400 in degrees
SUB MENU	2A7a	Tilt Filtered	not used on IBC Cart
	2A7b	Tilt Local	Actual measurement from GP400 tilt sensor
	2A8	Tilted Y/N	Indicates tilted state. Drive functions interlocked when elevated above proximity switch
	2A9	Height	not used on IBC Cart
	2A10	Load	not used on IBC Cart
	2A11	Overloaded Y/N	not used on IBC Cart
	2A12	Last Moved	not used on IBC Cart
	2A13	Elevated Y/N	Shows platform elevation is above proximity switch, drive slows and level sensor active.
	2A14	Outrigger (level)	not used on IBC Cart
	2A15	Axle	not used on IBC Cart
	2A16	Gen State	not used on IBC Cart

SELECTION	ID #	EZ-cal Readout	Explanation
2b PLATFORM	2B1	Trigger On/Off	Current status of enable trigger, pulled = ON - platform controller
	2B2	DLD	Position of Lift/Drive selector switch
	2B3	Joystick	Indicates % of stroke from center in real time of forward box. Direction not indicated here.
	2B4	Joystick #2	Indicates % of stroke from center in real time of reverse box. Direction not indicated here.
	2B5	Fwd/Down off/on	Indicates Forward joystick movement beyond center deadband
	2B6	Rev/Up off/on	Indicates Reverse joystick movement beyond center deadband
	2B7	Left off/on	Status of Left Steer switch
	2B8	Right off/on	Status of Right Steer switch
	2B9	Posi-track yes/no	not used on IBC Cart
	2B10	EMSp off/on	not used on IBC Cart
	2B11	IBC MODULE	
	2B12	IBC STEER	
2c GROUND	2C1	Up off/on	Status of Up switch from lower control station
	2C2	Down off/on	Status of Down switch from lower control station
	2C3	Out off/on	Status of Side Shift Left switch from lower control station
	2C4	In off/on	Status of Side Shift Right switch from lower control station
	2C5	EMSp off/on	not used on IBC Cart
2d INPUTS	2D1	P7-1	12V supply from Motor Controller. ON= Voltage, OFF= no voltage
	2D2	P7-2	Base selected, ON= selector on Base position - unit operating from base controls
	2D3	P7-3	Up selected from base controls, ON= Up activated
	2D4	P7-4	Platform Selected. ON= selector in platform position.
	2D5	P7-5	Platform Down Proximity switch. On= platform down.
	2D6	P7-6	Platform Side Shift Left. ON= selected from lower control panel
	2D7	P7-7	Down selected from base controls, ON= Down activated
	2D8	P7-10	Glow Plugs. ON= selected from lower control panel
	2D9	P7-11	Platform Side Shift Right. ON= selected from lower control panel
	2D10	P7-12	Engine Start. ON= selected from lower control panel
	2D11	P7-13	Engine Oil Pressure switch. ON= engine oil pressure sensed
	2D12	P7-14	Engine Coolant overheat. ON= overheat condition
	2D13	P15-9	Proximity Switch. On= platform completely elevated - lift function stops

SELECTION	ID #	EZ-cal Readout	Explanation
2e ANALOGS	2E1	none	No GP400 Analog inputs on IBC Cart
	2E1A	P8-3	Rear steer position sensor output - 0 to 5 volt output, ~2.50 v = centered
	2E1B	P8-4	Front steer position sensor output - 0 to 5 volt output, ~2.50 v = centered
	2E2	Matrix Analogs	Press ENTER for Analog inputs from upper control station
	2E2a	M2-6	Drive Joystick Hall Effect sensor. Displays position of Joystick in DC volts
	2E2b	M2-7	Steer rocker Hall Effect sensor. Displays position of rocker lever in DC volts
2f OUTPUTS refers to plug number and pin number (example P5-6) P5 is the plug 6 refers to pin 6 Refer to Schematic via.	Numbers NOT listed below but appear on EZ-cal - are not used		
	2F1	P4-1	Platform Lift Valve
	2F2	P4-2	Side Shift Left Valve
	2F3	P4-3	Side Shift Right Valve
	2F4	P4-4	Drive Forward Valve
	2F5	P4-5	Drive Reverse Valve
	2F6	P4-7	Steer Left signal
	2F7	P4-8	Steer Right Valve
	2F8	P4-14	Platform Lower Valve
	2F9	P5-6	Alarm Signal (optional)
	2F10	P5-9	Hour Meter signal B+. ON= Meter activated
	2F11	P5-14	Start Inhibit Warning Light. Alerts when starter operated excessively and is interlocked.
	2F12	P5-15	Parking Brake Release Valve
	2F13	P6-1	Glow Plug Relay Signal
	2F14	P6-2	Engine Start Relay Signal
	2F15	P6-3	Throttle Relay Signal
	2F16	P6-6	Alternator Excite signal
	2F17	P6-7	Diesel Fuel Solenoid Hold Signal
	2F18	P6-8	Drive Lights Relay Signal
2F19	P6-9	Work Lights Relay Signal	
2h LOG	2g1	Cal Date	Date of Last calibration (height or load)
	2g2	Software	MEC specific software.
	2g3	Powered	Accumulated time GP400 powered up (red LED on)
	2g4	Max Battery	Maximum Battery Voltage applied to system

EZ-CAL RETRIEVE MODE AND HELP MESSAGES

NOTE: *It is important to understand that an error message will only be available if the red Diagnostic LED is flashing. If the machine is not operating properly and the red Diagnostic LED is not flashing, the trouble may lie with something not monitored by the electronic control system, i.e. a switch, hydraulic valve or wiring damage.*

There are two different menus that you can access for message retrieval; MODE and HELP.

MODE MENU

Allows the technician to see the current state of the controller with a short description. Go to, DIAGNOSTICS/SYSTEM/MODE (EZ-Cal Flow Chart 2, ID# 2a1). Pressing ENTER a second time will provide additional information with certain messages.

HELP MENU

Provides various HELP messages to identify failure modes.

Some error messages may also be identified by counting the number of times the red LED flashes on the controller so that even without access to an EZ-Cal, some simple diagnostics are possible. However, it is recommended to use an EZ-Cal to diagnose problems, and not rely on the LED! The EZ-Cal provides a much higher detail of information.

MODE MESSAGE

- Connect the EZ-Cal (see illustration).
The display will read, "HELP: PRESS ENTER".
- Press Enter to display the current message.
- Refer to the following list of HELP messages to better understand the nature of the message or fault.
- If the GP400 does not register a fault, the display will read EVERYTHING OK.

SCROLLING MESSAGE

Pressing **ENTER** twice will provide a scrolling message of the current message (if one exists) followed by a log of previous operations and/or errors that occurred immediately prior, starting with most recent. **All messages are cleared whenever the system is powered down.**

Other helpful menus available include **DIAGNOSTICS** which allows the technician to monitor specific plug input/output information. Refer to EZ-Cal Flow Chart 2 – Diagnostics.

MODE MESSAGES

The purpose of **MODE** is to indicate, in real time, the current state of the controller with a short description.

INITIALIZING

- The system is preparing to operate, immediately after power-on.

SHUTDOWN!

- The system cannot operate – for example both the PLATFORM & GROUND inputs are active together.

CHECK CANBUS

- The system cannot operate – CANBUS communications is not successful (for example wire damage to the platform)

PLATFORM, GROUND

- The system is ready to operate, from the upper or lower controls as indicated (selected by the Base/Platform selector switch)

GROUND UP, GROUND DOWN,

- A ground function is operating normally

GROUND UP LOCKED, GROUND DOWN LOCKED,

- A ground function is selected but not allowed (for example, the function switch was closed at power-on)

GROUND FAULTY

- Multiple ground function inputs are active at the same time

WAITING FOR TRIGGER

- A platform function is selected, but the joystick trigger switch is not closed (close the trigger switch to proceed)

TRIGGER CLOSED

- The joystick trigger switch is closed, but no function is selected (select a function to proceed)

TRIGGER LOCKED

- The joystick trigger switch was closed at power-on, or closed for too long with no function selected (check trigger switch)

FORWARD, REVERSE

- A platform drive function is operating normally

FORWARD (LEFT), FORWARD (RIGHT), REVERSE (LEFT), REVERSE (RIGHT)

- A platform drive function is operating normally, with steer also active

STEER LEFT, STEER RIGHT

- A platform steer function is operating normally (without drive)

UP, DOWN

- A platform lift/lower function is operating normally

FORWARD LOCKED, REVERSE LOCKED

- A platform drive function is selected but not allowed (for example, the switch was closed at power-on)

LEFT LOCKED, RIGHT LOCKED

- A platform steer function is selected but not allowed (for example, the switch was closed at power-on)

UP LOCKED, DOWN LOCKED

- A platform lift/lower function is selected but not allowed (for example, the switch was closed at power-on)

CHECK DRIVE/LIFT

- Neither platform drive nor platform lift select is active, or both are active at the same time

CHECK JOYSTICK

- Both platform joystick directions are active at the same time

STEER FAULTY

- Both platform steer directions are active at the same time



EXTENDING LEGS

- Outrigger legs are extending normally

RETRACTING LEGS

- Outrigger legs are extending normally

OUTRIGGERS LOCKED

- An outrigger function is selected but not allowed (for example, the switch was closed at power-ON)

INTERLOCKED**

- An interlock shutdown is active, preventing one or more functions. The interlock can be due to many different causes ...

Press <ENTER> from the **MODE display to see the precise cause of the interlock (listed below) – press <ESC> from that display to return to the **MODE** display:

TEST MODE

- The system test mode is active – switch power off and on again to clear

TILTED

- The vehicle is tilted beyond limits, descend, then move vehicle to a more level location

TOO HIGH

- The vehicle platform is too high to allow some functions – descend first

TOO HOT

- The EZLIFT heatsink has reached 75°C, preventing all functions except lowering. Functions will be allowed again when the heatsink cools to below 70°C.
- The heatsink temperature can be viewed in the DIAGNOSTICS/SYSTEM/ TEMPERATURE display, ID # 2a5.
- The heatsink must be bolted to a significant metal panel of the vehicle, capable of dissipating heat to the environment.

UNCALIBRATED

- The height and/or pressure sensors have not been calibrated see CALIBRATION OF OVERLOAD SYSTEM (**CE option only**).
- If machine is not equipped with Overload system, refer to SETUPS table and change those personalities that do not match the figure listed in the table.

EXTERNAL ALL, EXTERNAL DRIVE, EXTERNAL LIFT

- An external cutout input is preventing functions – determine the cause of the external cutout (for example, a limit switch)

EZ-CAL HELP MESSAGES

In addition to the **MODE** messages detailed above, the GP400 provides a **HELP** message to identify failure modes. Some error messages may also be identified by counting the number of times the red LED flashes on the controller so that even without access to an EZ-Cal, some simple diagnostics are possible. However, it is recommended to use an EZ-Cal to diagnose problems, and not rely on the LED! The EZ-Cal provides a much higher detail of information.

- Connect the EZ-Cal (see illustration).
The display will read, "HELP: PRESS ENTER".
- Press Enter to display the current message.
- Refer to the following list of HELP messages to better understand the nature of the message or fault.
- If the GP400 does not register a fault, the display will read EVERYTHING OK.

Pressing ENTER twice will provide a scrolling message of the current message (if one exists) followed by a log of previous operations and/or errors that occurred immediately prior, starting with most recent. **All messages are cleared whenever the system is powered down.**

NOTE: When using the LED to attempt diagnosis, please note that a **DUAL FLASH** code is indicated. The LED will flash on/off a certain number of times, pause off for a short delay, then flash on/off a second certain number of times, followed by a much longer pause off. The sequence will then repeat.

INFORMATION ONLY MESSAGES

The following are "information only" HELP messages which are not indicative of any possible problem – there is no LED flash code (the LED remains on steady):

STARTUP! _____ (no flash code)

- The system has just been powered on and is carrying out some initialization steps prior to being ready to operate. If you select a function during this time, it may be locked out until you release then re-select it.

EVERYTHING OK _____ (no flash code)

- There is no problem with the system – it is ready to operate in platform mode when a function is selected.

NOTE: *If this is the HELP message when a function is selected, check for open-circuit switches or wiring.*

GROUND MODE ACTIVE! _____ (no flash code)

- There is no problem with the GP400 – it is ready to operate in ground mode when a function is selected.

CLOSE TRIGGER _____ (no flash code)

- A platform function is selected but the trigger switch is not closed.

VEHICLE TILTED _____ (no flash code)

- The vehicle is tilted beyond the limits, some functions may be prevented.

FUNCTION ACTIVE MESSAGES

The following **HELP** messages indicate that there is no problem with the GP400 but that a function is active – the vehicle should be moving as requested by the operator.

DRIVING! _____ (no flash code)

LIFTING! _____ (no flash code)

LOWERING! _____ (no flash code)

STEERING! _____ (no flash code)

EXTENDING OUTRIGGERS! _____ (no flash code)

RETRACTING OUTRIGGERS! _____ (no flash code)

CALIBRATION MESSAGES

The following are “calibration” HELP messages – until the machine is properly calibrated for height and/or pressure (as required), many functions will not be available.

NOT CALIBRATED _____ **Flash Code: 1/1**

FUNCTIONS LOCKED - NOT CALIBRATED _____ **Flash Code: 1/1**

- The height and/or pressure sensors have not been calibrated and are required because of the setup of the GP400.
- Calibration procedures are accessible from the **SETUPS/HEIGHT SETUPS** and **SETUPS/LOAD SETUPS** menus.

FAULT: CUSTOMER _____ **Flash Code: 1/1**

- The system must be configured to the customer requirements – with the EZ-Cal in **SETUPS/CHANGE DEFAULTS** menu, scroll to the correct machine from this menu, the press Right Arrow to select the appropriate model.

NOTE: Selecting the incorrect customer or model will cause the machine to operate incorrectly or go into fault mode.

SHUTDOWN HELP MESSAGES

This section lists “shutdown” HELP messages – functions can be shut down to prevent them being used:

SHUTDOWN - CHECK EMS SWITCHES! _____ **Flash Code: 2/1**

- The Base/Platform selector switch position indicates the mode in which the system must operate if both are active together; the system does not know how to function

FUNCTIONS LOCKED - TEST MODE SELECTED _____ **Flash Code: 2/2**

- Test mode is not accessible with this system. Switch power off/on to reset to normal operation

FUNCTIONS LOCKED - TOO HIGH _____ **Flash Code: 2/2**

- The platform is raised too high to allow some functions. Certain functions may not be allowed above certain elevations.
- Check operator’s manual or ADJUSTMENTS/HEIGHTS/MAX DRIVE and MAX LIFT to see if drive and/or lift is allowed at all heights.

FUNCTIONS LOCKED - TILTED _____ **Flash Code: 2/2**

- The vehicle is tilted too much to allow some functions.
- Check operator’s manual or ADJUSTMENTS/TILT/Xtrip and Ytrip, which determine the maximum allowed vehicle tilt.
- Refer to EZ-Cal Flow Chart 1 – Adjustments and Setup.

FUNCTIONS LOCKED - EXTERNAL SHUTDOWN _____ **Flash Code: 2/2**

- An external shutdown is preventing functions – check DIAGNOSTICS/SYSTEM/ MODE/INTERLOCK to see which external interlock is active.

CHECK GROUND INPUT SWITCHES! _____ **Flash Code: 2/2**

- There is a problem with the ground function select switches – more than one is active at the same time.

SELECT DRIVE/LIFT MODE! _____ **Flash Code: 2/2**

- There is a problem with the platform drive/lift select switch – neither mode is selected.

CHECK DRIVE/LIFT SELECT SWITCH! _____ **Flash Code: 2/2**

- There is a problem with the platform drive/lift select switch – both modes are selected together.

CHECK JOYSTICK SWITCHES! _____ **Flash Code: 2/2**

- There is a problem with the platform joystick switches – both directions are selected together.

RELEASE TRIGGER! _____ **Flash Code: 2/2**

- The trigger was closed at power-on, or closed for too long with no function selected.

RELEASE GROUND SWITCHES! _____ **Flash Code: 2/2**

- Ground function switches were closed at power-on.

RELEASE JOYSTICK SWITCHES! _____ **Flash Code: 2/2**

- Platform joystick switches were closed at power-on, or closed for too long without trigger switch (see **SETUPS/INTERLOCKS/TRIGGERwait**).

RELEASE OUTRIGGER SWITCHES! _____ **Flash Code: 2/2**

- Outrigger switches were closed at power-on.

WIRING MESSAGES

The following are “wiring” HELP messages – problems have been detected which are likely due to vehicle wiring issues:

FAULT: ENERGIZED VALVE - CHECK P5 WIRING! _____ **Flash Code: 3/2**

FAULT: VALVE FEEDBACK HIGH - CHECK VALVE WIRING! _____ **Flash Code: 3/2**

- There is a voltage on one or more valve outputs, when all outputs are off.
- Check each valve output to trace where the invalid supply is coming from.

FAULT: CAPBANK VOLTAGE TOO HIGH - CHECK LINE CONT! _____ **Flash Code: 3/3**

- The voltage on the B+ stud of the controller (connected to an internal voltage stabilization capacitor bank) is too high when the line contactor is off. B+ stud voltage should be approximately 32 volts at idle.
- Check the line contactor tips are not welded, and check the power wiring for errors.

FAULT: ENERGIZED LINE CONTACTOR - CHECK P5 WIRING! _____ **Flash Code: 3/4**

- There is a voltage on the line contactor coil output, when it is off.
- Check wiring to the line contactor coil to trace where the invalid supply is coming from.

FAULT: MOTOR OVERLOAD! _____ **Flash Code: 3/5**

- The power protection circuits in the controller have activated to protect from extreme overload.
- Check for short-circuit power wiring; check for a seized or shorted motor.

SUPPLY MESSAGES

The following are “supply” HELP messages – problems have been detected which are likely due to supply issues:

FAULT: LOW OIL PRESSURE! _____ **Flash Code: 4/1**

- Engine oil pressure switch open after start sequence initiated. Engine stalled or unable to start.

FAULT: BAD INTERNAL 5V! _____ **Flash Code: 4/2**

- The internal “5V slave” supply is out of range; if the fault remains, the controller may have to be replaced.

FAULT: BAD INTERNAL SLAVE! _____ **Flash Code: 4/2**

- The internal “slave” is not operating correctly; if the fault remains, the controller may have to be replaced.

FAULT: BAD INTERNAL 12V! _____ **Flash Code: 4/3**

- The internal “12V” supply is out of range;
- 12V Supply is generated by the Motor control module and supplied to the GP400. Check for wiring errors between the two modules. If the fault remains, the Motor Controller may have to be replaced.

FAULT: BATTERY VOLTAGE TOO LOW! _____ **Flash Code: 4/4**

- The battery supply is too low – the batteries must be re-charged.

FAULT: BATTERY VOLTAGE TOO HIGH! _____ **Flash Code: 4/4**

- The battery supply is too high – check that the correct battery and charger are installed.

FAULT: BAD 5V SENSOR SUPPLY - CHECK P2-1 WIRING! _____ **Flash Code: 4/5**

- The “5V sensor” supply is out of range; this supply is available to power external 5V-powered sensors – check that it has not been overloaded or short-circuited to other wiring (CE models).

CANBUS MESSAGES

This section lists “CANBUS” HELP messages – problems have been detected with CANBUS communications between different modules (of course, only applicable if more than one module is connected together via CANBUS):

FAULT: CANBUS! _____ **Flash Code: 6/6**

- There are problems with CANBUS communications between the different modules; messages expected from one or more module are not being received, or messages intended to one or more module cannot be transmitted.
- Check for open- and short- circuit problems with CANBUS wiring; ensure that the CANBUS is wired correctly pin-to-pin; ensure that the vehicle chassis is not erroneously shorted to the chassis (for example, due to insulator breakdown in the motor).

POWER WIRING MESSAGES

The following are “power wiring” HELP messages – problems have been detected which are likely due to power wiring errors:

FAULT: CAPBANK VOLTAGE TOO LOW - CHECK STUD WIRING! Flash Code: 7/7

- The voltage on the B+ stud of the controller (connected to an internal voltage stabilization capacitor bank) is too low when the line contactor is off (a pre-charge circuit in the module normally applies approximately 32 volts to the capacitor bank).
- Check the 300 amp fuse, line contactor or power wiring for errors. Also check DC motor for internal grounding.

OTHER MESSAGES

The following are other HELP messages:

SOME BIG BAD PROBLEM! _____ **Flash Code: 9/9**

- This message should not occur!

FACTORY OVERRIDE _____ **Flash Code: (fast flashing)**

- When the controller is first shipped, prior to initial calibration, it is configured in a special “factory override” state. In this state, none of the normal shutdowns or interlocks will occur – the vehicle can be freely lifted/lowered and driven irrespective of any calibration needs, vehicle tilt, etc.
- As soon as an EZ-Cal is connected to the controller, the factory override state is ended.
- If calibration does not occur, then the factory override state will recur if the EZ-Cal is disconnected and power is switched off/on.

IMPORTANT: – Never use a vehicle in factory override; this state is **ONLY** intended for use during manufacture! While factory override is active, the LED is rapidly flashed on/off.

TROUBLESHOOTING CHART

The following chart is a guide to help the technician find the area of a problem. In order to benefit from the information, you are advised to fully assess the symptoms by operating all machine functions. There may be some functions that operate while others may not. Record this information and proceed down the left-hand column until you find the failure scenario that best fits the problem. Refer to the information provided to the right for possible causes and remedies. This unit contains a Microprocessor based control system which contains various safety features designed to protect itself and the operator in the event of a failure.

The EZ-Cal scan tool will provide the technician with detailed information related to the failure. ***It is strongly recommended that the technician use the EZ-Cal to read any displayed messages before proceeding to use this Troubleshooting chart.***

Information on the use of the EZ-cal tool plus helpful Flow Charts and graphs can be found earlier in this troubleshooting section. Please read and familiarize yourself with all of the information provided in the troubleshooting section before attempting to diagnose or repair the machine.

Table 4-3: Troubleshooting Table

Problem	Possible Cause	Remedy/Solution
General Power Issue		
No operation from upper or lower control station. No Red LED at GP400.	Emergency switch pushed in or is defective.	Upper or lower e-stop switch will cut all power.
	Ignition switch turned off or defective.	Ignition switch located in the upper control box must be in the Run position before operation from either station.
	Battery discharged.	Will receive 4-4 or 7-7 flash on GP400. Clean, service and charge battery. Charging system may not operate if battery voltage drops below 13 volts.
	Blown 30 amp fuse.	Located on the starter in the engine compartment.
	Circuit breaker tripped.	Located in lower control box panel.
	Damaged upper control box harness.	Inspect from harness plug to terminal strip under platform. May receive 6-6 flash code on GP-400 (CAN bus).
	Other fault in system monitored by GP400.	Check Help message on EZ-cal or check flash code for error.
Functions from lower controls but not from upper controls	Interlock switch (joystick).	Check power to red wire (power to switch) and power to purple wire (power out of switch) at joystick plug.
	Loose plug connections on Matrix module.	Check plug connections.
	Damaged upper control box harness.	Inspect from harness plug to terminal strip under platform. May receive 6-6 flash code on GP-400 (CAN bus).
	System interlock.	Check HELP messages using EZ-cal.

Table 4-3: Troubleshooting Table

Problem	Possible Cause	Remedy/Solution
LIFT/LOWER		
Platform will not Raise	Excessive weight on platform.	Reduce weight to rated platform capacity.
	Mast not lubricated sufficiently.	Spread grease over areas where slide pads contact.
	Lift relief valve RV2 out of adjustment.	Adjust relief valve to rated platform capacity.
	Lift valve SP2 not energized.	Check wiring to lift valve. Check for EZ-cal message or flash code.
	Lowering valve SV3 stuck open (located at base of lift cylinder).	Check and remove contamination from valve.
	Main system pressure inadequate.	Check pump output pressure.
	Level sensor out of level (platform elevated above 1').	Reposition machine to firm level surface. Check level sensor function using EZ-cal. See Diagnostic chart 2e1.
	Battery discharged.	Will receive 4-4 or 7-7 flash on GP400. Clean, service and charge battery. Charging system may not operate if battery voltage drops below 13 volts.
	System interlock.	Check HELP messages using EZ-cal.
	Faulty Check Valve CV1 or CV3.	Remove and inspect/replace valves.
Platform raises uncommanded when operating other functions	Lift valve SP2 sticking.	Clean or replace SP2 valve.
	Check Valve CV2 damaged or contaminated.	Clean or replace CV2 valve. See hydraulic diagram for location.
Platform will not lower or lowers slowly	Maintenance lock holding platform up.	Remove maintenance lock.
	Lowering valve not energized.	Check wiring to lowering valve located on Lift Cylinder. Check for EZ-cal message or Flash code.
	Lowering valve not shifting.	Clean debris. Check for damage/replace.
	Valve coil failed on cylinder.	Test (8 - 12 ohms)/replace
	Lowering orifice ORF2 plugged.	Clean orifice located inside hose fitting on lift cylinder.
	System interruption.	Check HELP messages using EZ-cal.
Platform Lowers uncommanded (drift down)	Lowering valve SV3 sticking or contaminated.	Deploy Maintenance Lock! Remove and clean or replace lowering valve SV3.
	Cylinder internal seal failure.	Check/repair seals.
	Emergency Lowering cable binding.	Check/replace cable.
Emergency lowering not working	Lowering valve not shifting.	Clean debris, check for damage, replace.
	Lowering orifice ORF3 plugged.	Clean orifice located in Lift cylinder hose port.
	Emergency lowering cable binding.	Check/replace cable.
DRIVE:		
No drive function	Drive Valve PE1 not shifting.	Remove PE1 valve. Check for debris/replace.
	Lift/Drive select switch malfunction.	Check continuity through switch or use EZ-cal tool to check 2B-2 (diagnostic flow chart).
	Drive system interlock.	Check HELP and MODE messages on EZ-cal.

Table 4-3: Troubleshooting Table

Problem	Possible Cause	Remedy/Solution
Drive operates uncommanded when operating other functions	Drive valve PE1 sticking or damaged.	Clean/replace PE1 valve. See hydraulic diagram.
	Drive proportional valve EHPR1 or EHPR2 sticking or damaged.	Check/replace EHPR1 or EHPR2 valves.
	Shuttle valve LS3 damaged or contaminated.	Clean/replace LS3 valve. See hydraulic diagram for location.
	Electrical short circuit commanding EPHR1 or EPHR2 valve to shift.	Check for errant voltage at the valve coils.
No drive elevated	Unit out of level.	Lower and re-position the machine.
	System interlock.	Check HELP messages using EZ-cal.
	Wheel motor/s not functioning correctly.	Inspect wheel motors for excessive bypass.
	Brake release valve SV-2 inoperative.	Check 12 volts to appropriate coil. Check coil. Check valve function.
Slow drive with platform in stowed position	High torque enabled.	Check speed/torque switch in platform box.
	Elevation proximity sensor failure.	Use EZ-cal to monitor platform state of elevation. See Diagnostic chart I.D. 2d5 for elevated status.
	Wheel motor/s not functioning correctly.	Inspect wheel motors for excessive bypass.
	Brake release valve SV-2 inoperative.	Check 12 volts to appropriate coil. Check coil. Check valve function.
Poor gradability performance	High Speed enabled.	Check Speed/Torque switch.
	Wheel motor/s not functioning correctly.	Inspect wheel motors for excessive bypass.
	Malfunctioning series/parallel valves.	Located on top of main hydraulic manifold.
	Worn hydraulic pump.	Check with flow meter or repair/replace pump.
	Brake release valve SV-2 inoperative.	Check 12 volts to appropriate coil, check coil, check valve function.
Drive in one direction only	Drive valve EPHR1 OR EPHR2 not operating.	Check 12 volts to appropriate coil. Check coil. Check valve function.
	No output from GP400.	Scan using EZ-cal and troubleshooting charts. EZ-cal chart I.D 2f4 - Fwd or 2f5 - Reverse.
No low speed (high torque mode)	Speed/torque selector switch SV1 inoperative.	Check continuity of Speed/Torque switch in platform control box.
	Valves EP1 or PD1 not functioning.	Remove valve and inspect for debris or damage. Replace faulty valve spool.
	EP1 poppet valve not functioning.	Check or replace valve.
No brake effectiveness	Brake release valve SV-2 inoperative.	Check 12 volts to appropriate coil, check coil, check valve function.
	Brake discs worn past service limit.	Replace brake discs located inside rear wheel motors.
LIFT AND DRIVE		
No drive or lift operation motor operates	Main relief valve out of adjustment.	Located on pump. Adjust as described in the service manual.
	System interlock.	Check HELP messages using EZ-cal.
	Hydraulic tank empty.	Check, fill with approved oil.
	Pump or pump coupler failure.	Inspect, replace as necessary.
STEER		

Table 4-3: Troubleshooting Table

Problem	Possible Cause	Remedy/Solution
No steer in either direction	Joystick rocker switch inoperative.	Check rocker switch output on green and yellow wires, input on blue wire.
	Steering valve SP1 inoperative.	Check steering valve for power or damage.
	System interlock.	Check HELP messages using EZ-cal.
	Steer select valves SV4 and SV5 not operating.	Check 12 volts to appropriate coil, check coil, check valve function.
	Cross port relief valves CR1 or CR2 inoperative.	Remove and inspect. Replace valves.
	Hoses connected incorrectly.	See Hydraulic Section for correct connection.
Steers in one direction only	Steering Valve SP1 inoperative or stuck	Inspect/replace steering valve.
	No power to steering coil.	Check for power and ground in both directions, repair wiring, replace coil.
	System interlock.	Check HELP messages using EZ-cal.
Steers but not fully or steers slowly	One or both steering cylinder internal seal failure.	Check steering cylinder seals, replace.
	King pin/s seizing in the bore.	Disassemble and inspect, repair, replace bushings.
Front & Rear Wheels do not stay in sequence while driving	Wheels can move out of sequence if steering is obstructed by obstacles.	To re-sequence steering, turn wheels all the way in one direction and hold for 10 seconds.
	Cross port relief valves CR1 or CR2 not adjusted correctly.	Check valve adjustment.
	One or both steering cylinder internal seal failure.	Check steering cylinder seals, replace.
Steers uncommanded	Steering valve SP1 sticking or damaged.	Remove and inspect for visible debris and stem straightness. Clean with solvent and air.
SIDE SHIFT		
No Side Shift in either direction	Debris in slide track preventing operation.	Clean slide track.
	Valve SP3 inoperative.	Remove and inspect for visible debris and stem straightness. Clean with solvent and air. Check for power and ground in both directions. Repair wiring. Replace coil.
	System interlock.	Check HELP messages using EZ-cal.
	Cross Port Relief Valve CR3 out of adjustment.	Check adjustment of valve. Replace.
	Cylinder leaking internally.	Inspect/repair or replace cylinder/s.

NOTES:



Section 5

SCHEMATICS

CONTENTS	PAGE
Hydraulic Schematic	5-2
Electrical Schematic	5-7

FIGURES	PAGE
Hydraulic Schematic	5-3
Functions Manifold, Shuttle Valve & Brake Release Valve	5-4
Drive Proportional/Drive Counterbalance Valve Assembly	5-5
Steering Valve Assemblies	5-6
Electric Schematic, Lower Control Box	5-7
Electric Schematic, Main Harness	5-8
Electric Schematic, Platform	5-9
Lower Controls	5-10
Upper Controls	5-10

NOTES:



REV.	ECN#	DRAWING REVISION RECORD	APPROVED DR/DSG/MFG	DATE
0	-	RELEASE FOR PRODUCTION	JS	7/6/2011

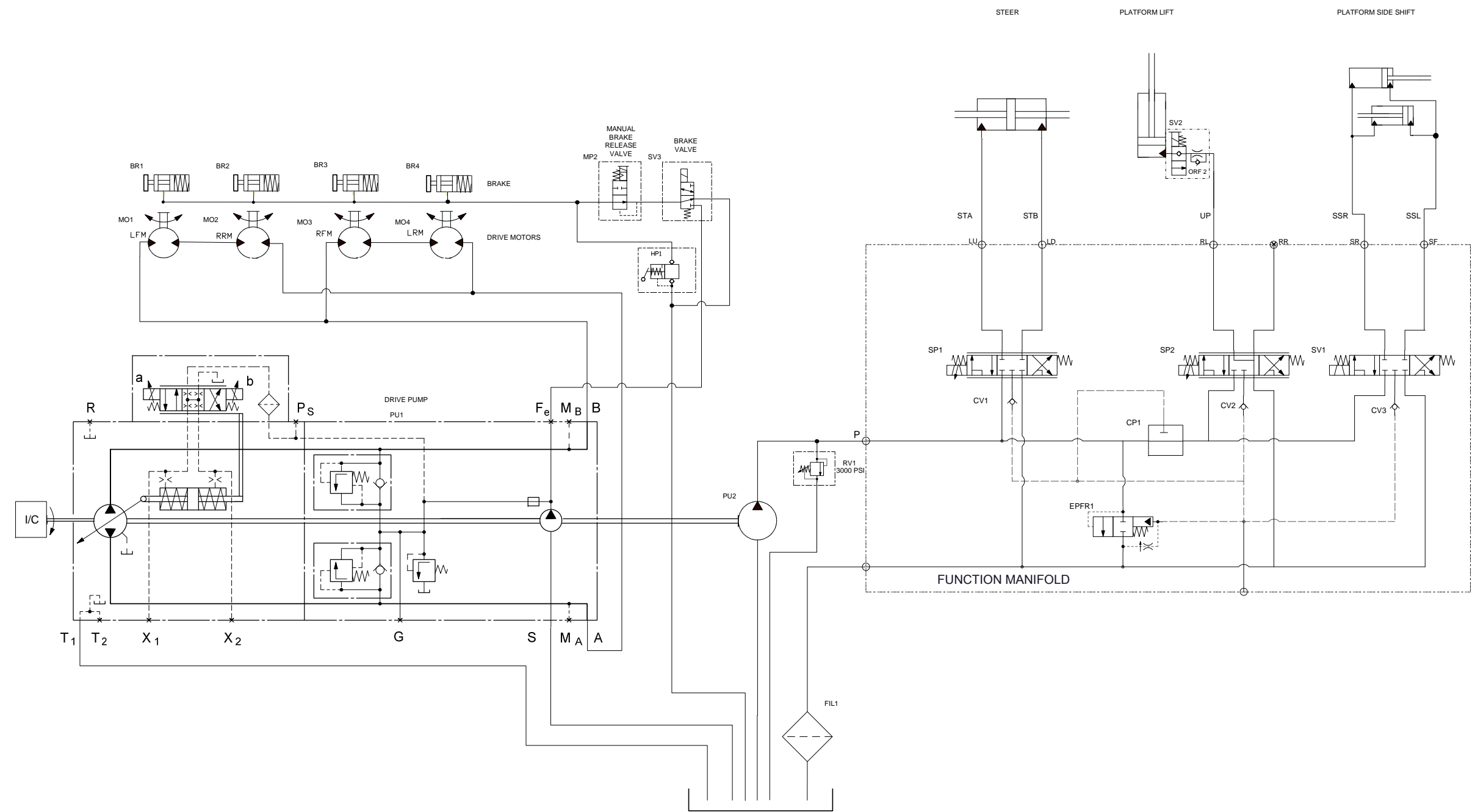

TOLERANCE UNLESS OTHERWISE SPECIFIED DIMENSIONS ARE IN INCHES		IBS CART HYDRAULIC SCHEMATIC DIAGRAM		MEC AERIAL WORK PLATFORMS	
3-PLACE (XXX)	± .015	SERIAL# 17010000 - 17010008		1401 S. MADERA AVE KERMAN, CA 93630	
2-PLACE (XX)	± .03	TITLE: 27205		PH: 877.632.5438 OR 559.842.1500 FX: 559.842.1520	
1-PLACE (X)	± .1	DRAWING NUMBER: 27205		SIZE: PART NO. 27205	
RADIUS (R)	± .03	TITAN 40 USED ON		REV 0	
HOLE DIAM.	± .005	WEIGHT		SHEET 1 OF 1	
ANGLE	± .1	SCALE		B	
INTERPRET GEOMETRIC TOLERANCING PER: ASME Y14.5		FINISH		1	

PROPRIETARY AND CONFIDENTIAL
 THE INFORMATION CONTAINED ON THIS DOCUMENT IS THE CONFIDENTIAL OR PROPRIETARY OF MEC AERIAL WORK PLATFORMS. DO NOT DISCLOSE, COPY, OR REPRODUCE WITHOUT WRITTEN AUTHORIZATION FROM MEC AERIAL WORK PLATFORMS.

REV 0
 27183
 D

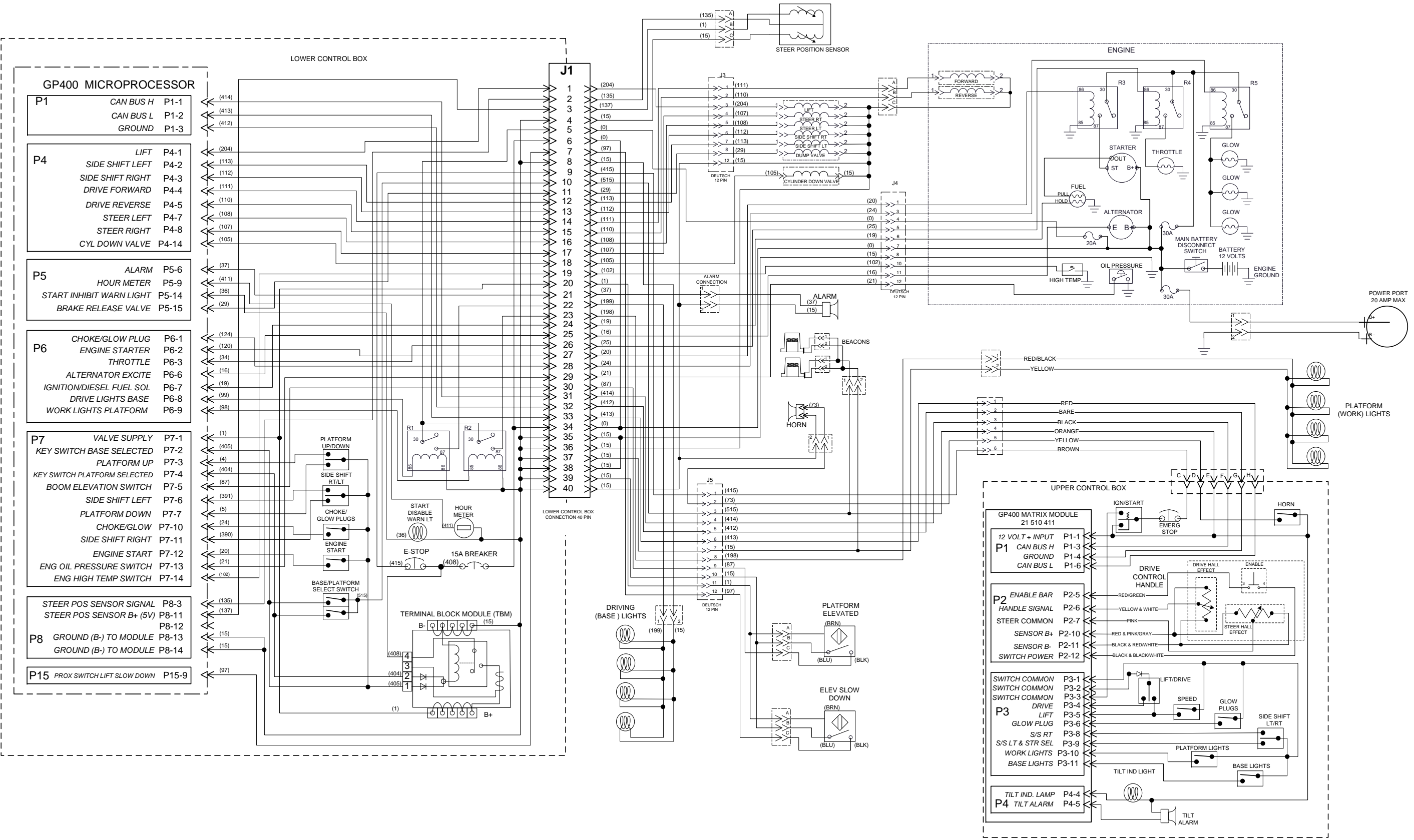

GP400 MICROPROCESSOR

- P1 CAN BUS H P1-1
- P1 CAN BUS L P1-2
- P1 GROUND P1-3

- P4 LIFT P4-1
- P4 SIDE SHIFT LEFT P4-2
- P4 SIDE SHIFT RIGHT P4-3
- P4 DRIVE FORWARD P4-4
- P4 DRIVE REVERSE P4-5
- P4 STEER LEFT P4-7
- P4 STEER RIGHT P4-8
- P4 CYL DOWN VALVE P4-14

- P5 ALARM P5-6
- P5 HOUR METER P5-9
- P5 START INHIBIT WARN LIGHT P5-14
- P5 BRAKE RELEASE VALVE P5-15

- P6 CHOKE/GLOW PLUG P6-1
- P6 ENGINE STARTER P6-2
- P6 THROTTLE P6-3
- P6 ALTERNATOR EXCITE P6-6
- P6 IGNITION/DIESEL FUEL SOL P6-7
- P6 DRIVE LIGHTS BASE P6-8
- P6 WORK LIGHTS PLATFORM P6-9

- P7 VALVE SUPPLY P7-1
- P7 KEY SWITCH BASE SELECTED P7-2
- P7 PLATFORM UP P7-3
- P7 KEY SWITCH PLATFORM SELECTED P7-4
- P7 BOOM ELEVATION SWITCH P7-5
- P7 SIDE SHIFT LEFT P7-6
- P7 PLATFORM DOWN P7-7
- P7 CHOKE/GLOW P7-10
- P7 SIDE SHIFT RIGHT P7-11
- P7 ENGINE START P7-12
- P7 ENG OIL PRESSURE SWITCH P7-13
- P7 ENG HIGH TEMP SWITCH P7-14

- P8 STEER POS SENSOR SIGNAL P8-3
- P8 STEER POS SENSOR B+ (5V) P8-11
- P8 GROUND (B-) TO MODULE P8-12
- P8 GROUND (B-) TO MODULE P8-13
- P8 GROUND (B-) TO MODULE P8-14

- P15 PROX SWITCH LIFT SLOW DOWN P15-9

UNLESS OTHERWISE SPECIFIED DIMENSIONS ARE IN INCHES	
3-PLACE (XXX)	± 0.15
2-PLACE (XX)	± 0.1
1-PLACE (X)	± 0.05
RADIUS DIM	± 0.03
HOLE DIAM.	± 0.005
ANGLE	± 1°
INTERFERING DIMENSIONS TOLERANCES PER ASME Y14.5	
MATERIAL	FINISH

ELECTRICAL SCHEMATIC
IBZ CART
 SERIAL # 17010001
 TITLE: 27204
 DRAWING NUMBER: 27204
 IBZ CART USED ON: 1
 SHEET 1 OF 1

MEC AERIAL WORK PLATFORMS
 1401 S. MADERA AVE
 KERNAN, CA 93630
 PH: 877.632.5438 OR 559.842.1500 FX: 559.842.1520
 SIZE: PART NO. 27204
 REV 0

PROPRIETARY AND CONFIDENTIAL
 THE INFORMATION CONTAINED ON THIS DOCUMENT IS THE CONFIDENTIAL OR PROPRIETARY INFORMATION OF MEC AERIAL WORK PLATFORMS. IT IS NOT TO BE REPRODUCED, COPIED, OR DISCLOSED IN ANY MANNER WITHOUT THE WRITTEN AUTHORIZATION FROM MEC AERIAL WORK PLATFORMS.

REV.	ECN#	DRAWING REVISION RECORD	APPROVED DR/DSG/MFG	DATE
A		RELEASE FOR PROTOTYPE	MT	11/08/2013

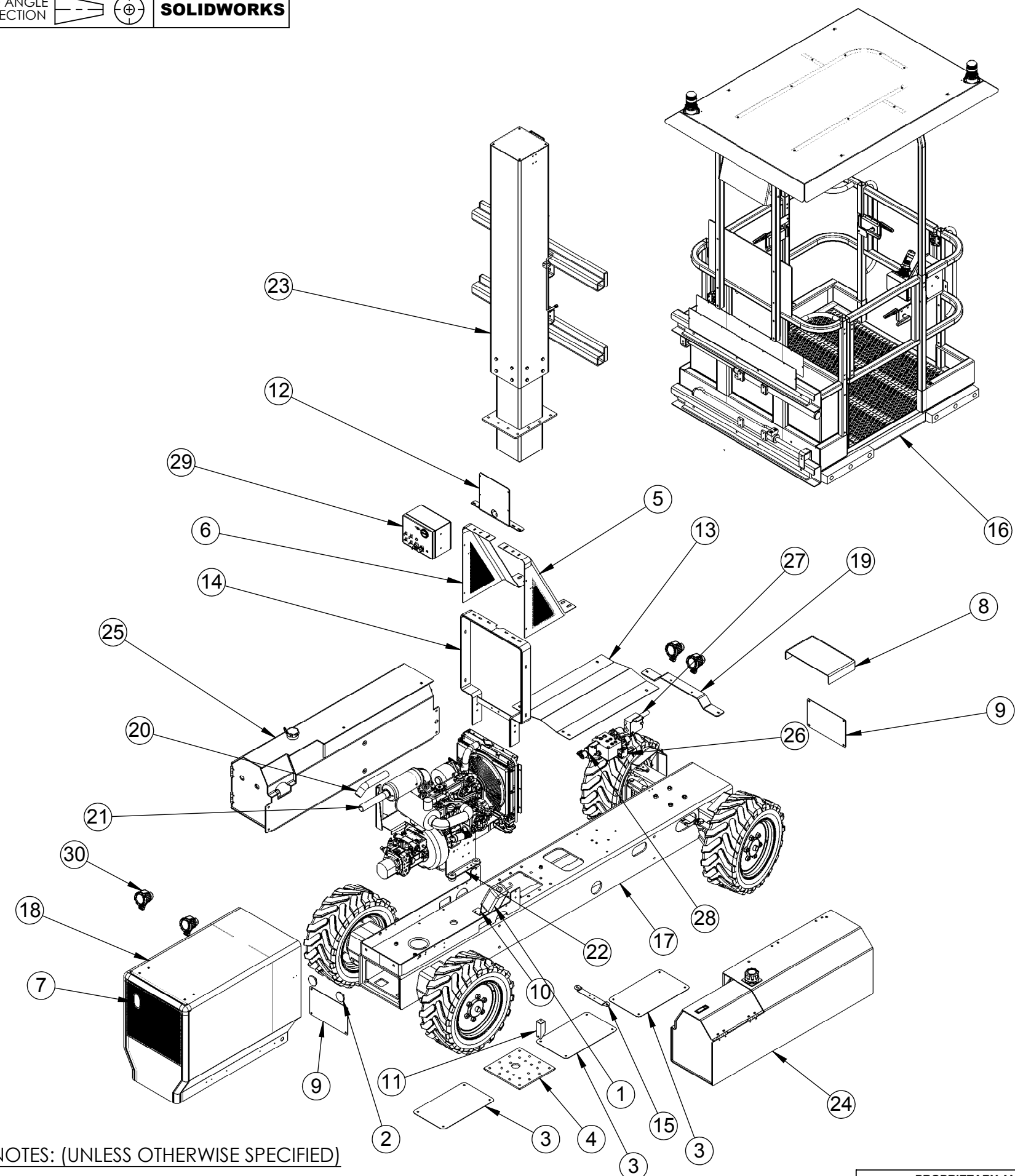

NOTES: (UNLESS OTHERWISE SPECIFIED)

- 1. BREAK SHARP EDGES

ITEM NO.	PART NUMBER	BOM NAME	QTY.
1	RADOFLOTNK		1
2	25429	SPACER, RUBBER	2
3	27017	LOWER CHASSIS COVER PLATE	3
4	27074	LOWER INNER MAST MOUNT	1
5	27091	RH RADIATOR COVER WELDMENT	1
6	27094	LH RADIATOR COVER WELDMENT	1
7	27097	ENGINE HOOD	1
8	27169	FRONT STEP	1
9	27219	CHASSIS FRONT COVER	2
10	27252	COOLANT TANK MOUNT ASSEMBLY	1
11	27256	E-DOWN CABLE BRACKET	1
12	27271	LOWER CONTROL BOX MOUNT WELDMENT	1
13	27276	HYDRAULIC MANIFOLD COVER WELDMENT	1
14	27277	ENGINE HOOD MOUNT WELDMENT	1
15	27294	HYDRAULIC FILTER MOUNT	1
16	27325	IBC PLATFORM ASSEMBLY	1
17	27364	CHASSIS ASSEMBLY	1
18	27367	ENGINE HOOD WELDMENT	1
19	27369	FRONT LIGHT MOUNTING PLATE	1
20	27376	MUFFLER EXTENSION TUBE	1
21	27378	MUFFLER EXTENSION TUBE	1
22	27401	UNION PACIFIC IBC ENGINE ASSEMBLY	1
23	27402	MAST ASSEMBLY	1
24	27403	HYD TANK ASSEMBLY	1
25	27404	FUEL TANK ASSEMBLY	1
26	84288	IBC FUNCTION MANIFOLD ASSEMBLY	1
27	84289	IBC BRAKE RELEASE MANIFOLD ASSEMBLY	1
28	84290	IBC BRAKE DUMP VALVE ASSEMBLY	1
29	92343	NEMA TYPE 4 JUNCTION ENCLOSURE	1
30	92365	WORK LIGHT HIGH OUTPUT LED, MEDIUM FLOOD 9-36V W/DUETSCH CONNECTOR XWL-810	4

TOLERANCE UNLESS OTHERWISE SPECIFIED DIMENSIONS ARE IN INCHES	
3-PLACE (XXX)	± .015
2-PLACE (XX)	± .03
1-PLACE (X)	± .1
RADIUS DIM	± .03
HOLE DIAM.	± .005
ANGLE	± 1°
INTERPRET GEOMETRIC TOLERANCING PER: ASME Y14.5	

IBC MKII ASSEMBLY	
TITLE:	
MATERIAL	
FINISH	



MEC AERIAL WORK PLATFORMS
 1401 S. MADERA AVE
 KERMAN, CALIFORNIA 93630
 PH:877.632.5438 OR 559.842.1500 FX:559.842.1520

PROPRIETARY AND CONFIDENTIAL
 THE INFORMATION CONTAINED ON THIS DOCUMENT IS THE CONFIDENTIAL PROPERTY OF MEC AERIAL WORK PLATFORMS. DO NOT DISCLOSE, COPY, OR REPRODUCE WITHOUT WRITTEN AUTHORIZATION FROM MEC AERIAL WORK PLATFORMS.

DRAWING NUMBER	84291	USED ON	
WEIGHT	3977.79 LBS	SCALE	1:28
SHEET	1 OF 1	SIZE	B
PART NO.	84291	REV	A

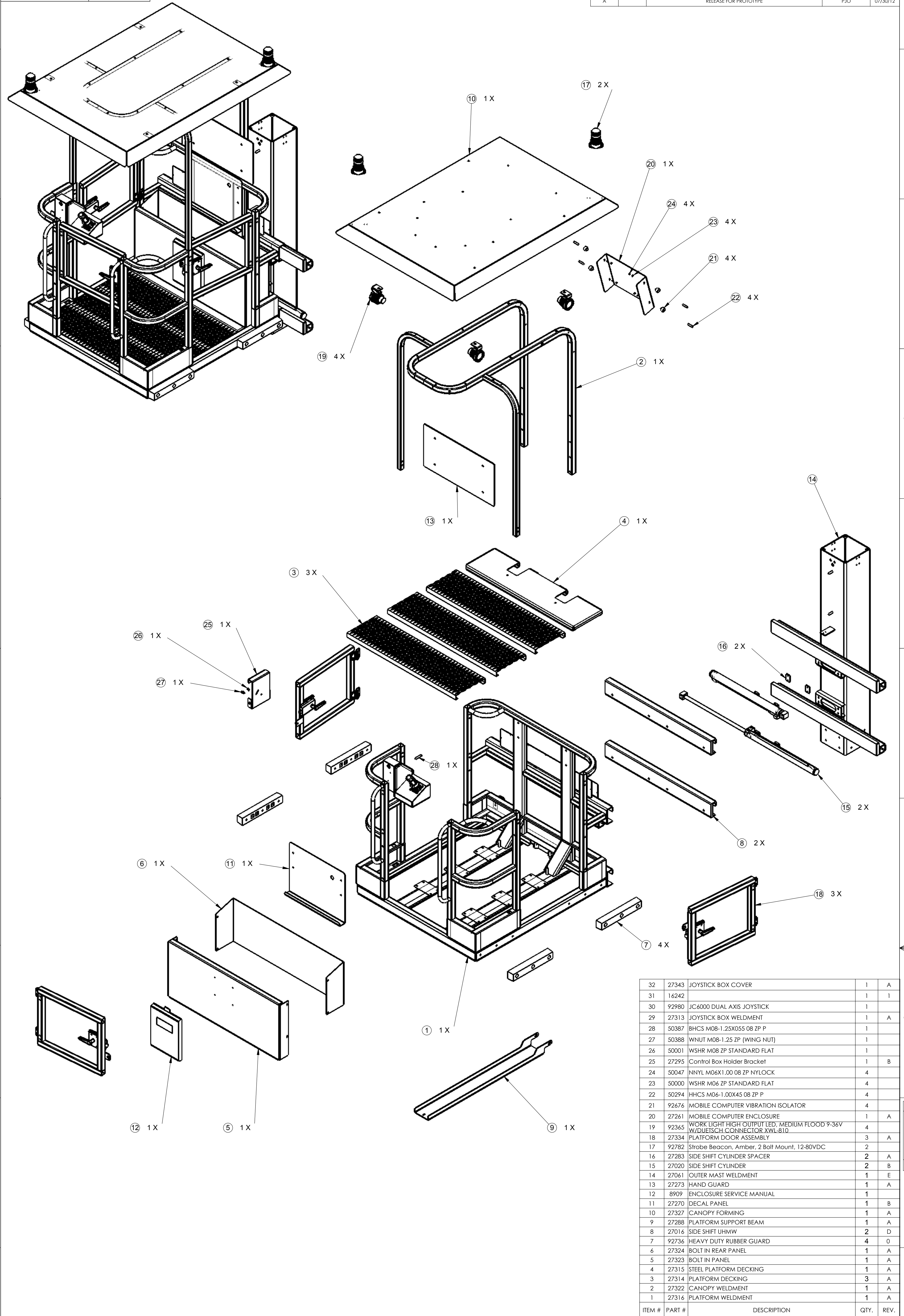

NOTES: (UNLESS OTHERWISE SPECIFIED)

1.

ITEM #	PART #	DESCRIPTION	QTY.	REV.
32	27343	JOYSTICK BOX COVER	1	A
31	16242		1	I
30	92980	JC6000 DUAL AXIS JOYSTICK	1	
29	27313	JOYSTICK BOX WELDMENT	1	A
28	50387	BHCS M08-1.25X055 08 ZP P	1	
27	50388	WNUT M08-1.25 ZP (WING NUT)	1	
26	50001	WSHR M08 ZP STANDARD FLAT	1	
25	27295	Control Box Holder Bracket	1	B
24	50047	NNYL M06X1.00 08 ZP NYLOCK	4	
23	50000	WSHR M06 ZP STANDARD FLAT	4	
22	50294	HHCS M06-1.00X45 08 ZP P	4	
21	92676	MOBILE COMPUTER VIBRATION ISOLATOR	4	
20	27261	MOBILE COMPUTER ENCLOSURE	1	A
19	92365	WORK LIGHT HIGH OUTPUT LED, MEDIUM FLOOD 9-36V W/DUETSCH CONNECTOR XWL-810	4	
18	27334	PLATFORM DOOR ASSEMBLY	3	A
17	92782	Strobe Beacon, Amber, 2 Bolt Mount, 12-80VDC	2	
16	27283	SIDE SHIFT CYLINDER SPACER	2	A
15	27020	SIDE SHIFT CYLINDER	2	B
14	27061	OUTER MAST WELDMENT	1	E
13	27273	HAND GUARD	1	A
12	8909	ENCLOSURE SERVICE MANUAL	1	
11	27270	DECAL PANEL	1	B
10	27327	CANOPY FORMING	1	A
9	27288	PLATFORM SUPPORT BEAM	1	A
8	27016	SIDE SHIFT UHMW	2	D
7	92736	HEAVY DUTY RUBBER GUARD	4	0
6	27324	BOLT IN REAR PANEL	1	A
5	27323	BOLT IN PANEL	1	A
4	27315	STEEL PLATFORM DECKING	1	A
3	27314	PLATFORM DECKING	3	A
2	27322	CANOPY WELDMENT	1	A
1	27316	PLATFORM WELDMENT	1	A

TOLERANCE UNLESS OTHERWISE SPECIFIED DIMENSIONS ARE IN INCHES	
3 PLACE (XXX)	± .015
2 PLACE (XX)	± .03
1 PLACE (X)	± .06
RADIUS (RM)	± .03
HOLE (DIA)	± .005
ANGLE	± 1°
INTERPRET GEOMETRIC TOLERANCING PER: ASME Y14.5	
MATERIAL	
FINISH	

TITLE: PLATFORM ASSEMBLY	
DRAWING NUMBER: 27325	IBZ USED ON:
WEIGHT: 1171.67 LBS	SCALE: 1:8
SHEET 1 OF 1	

MEC AERIAL WORK PLATFORMS
1401 S. Modesto Ave.
Kerman, CA 93630
PH: 559.842.1500 FX: 559.842.1510

SIZE: D	PART NO. 27325	REV. A
----------------	-----------------------	---------------

PROPRIETARY AND CONFIDENTIAL
THE INFORMATION CONTAINED ON THIS DOCUMENT IS THE CONFIDENTIAL PROPERTY OF MEC AERIAL WORK PLATFORMS. DO NOT DISCLOSE, COPY, REPRODUCE, OR TRANSMIT WITHOUT WRITTEN AUTHORIZATION FROM MEC AERIAL WORK PLATFORMS.

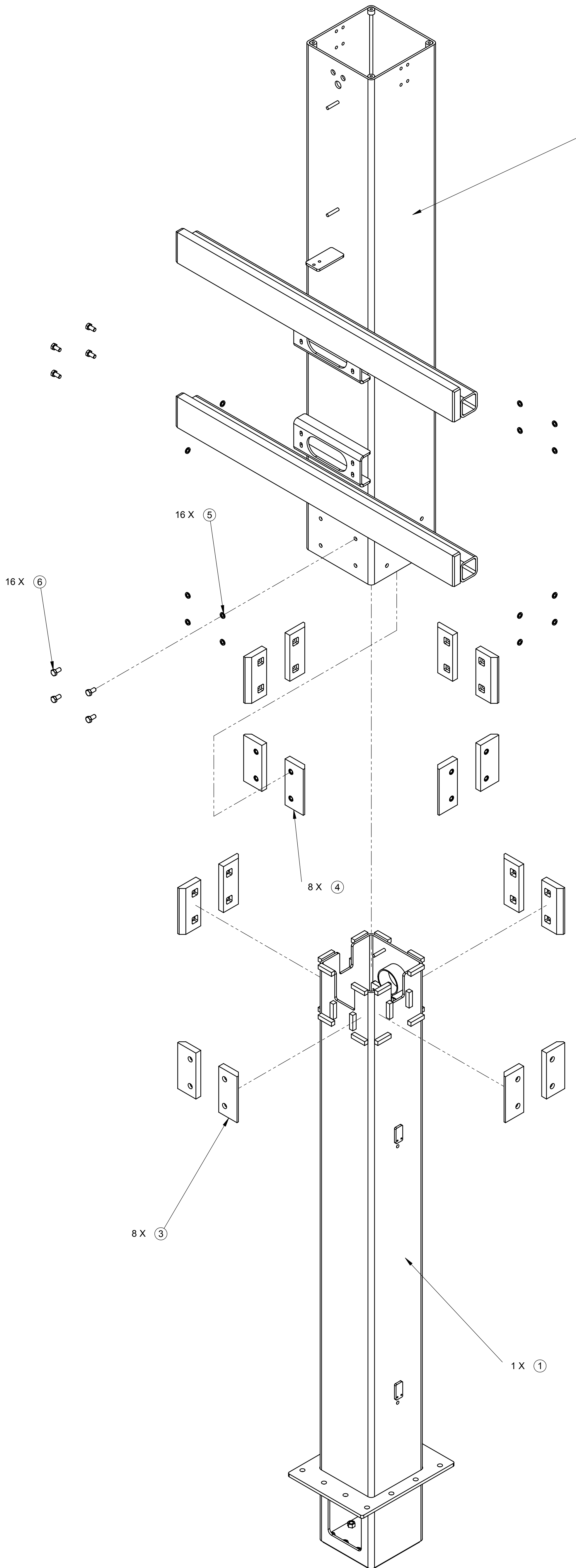

NOTE: ORIENT WEAR PADS SUCH THAT CORNERS ARE PARRELL

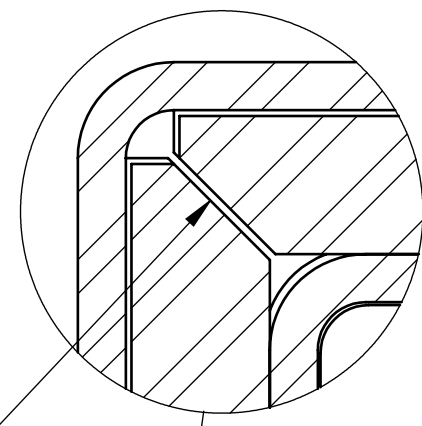

DETAIL C
SCALE 1 : 1

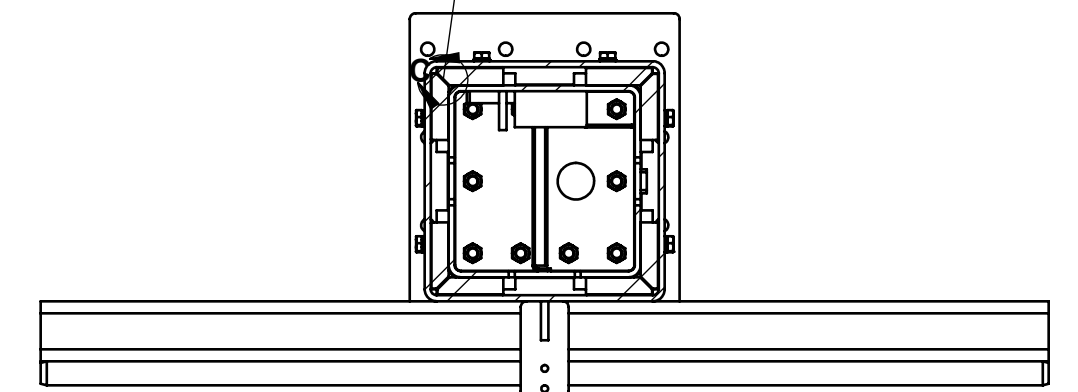

SECTION A-A
SCALE 1 : 8

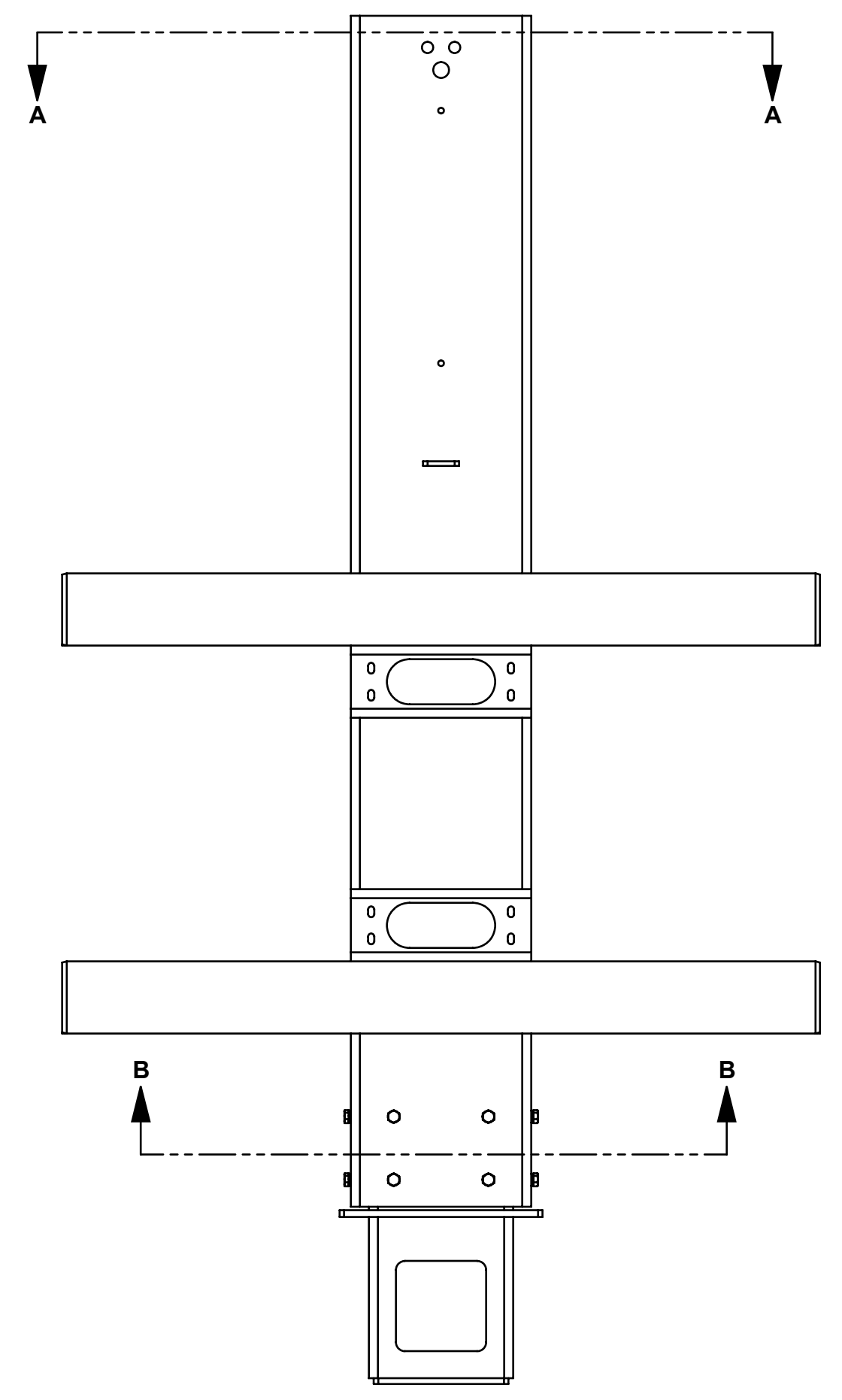

SECTION B-B
SCALE 1 : 8

NOTE: ORIENT WEAR PADS SUCH THAT CORNERS ARE FLUSH

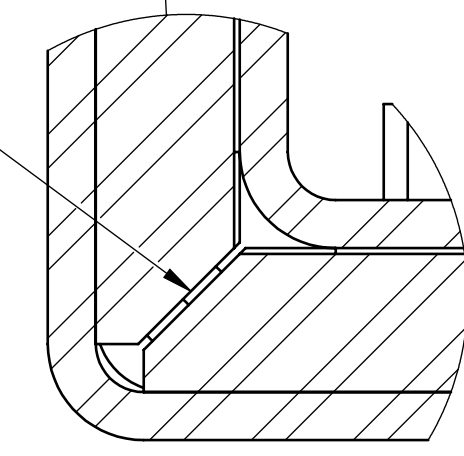

DETAIL D
SCALE 1 : 1

NOTES: (UNLESS OTHERWISE SPECIFIED)

1.

ITEM #	PART #	DESCRIPTION	QTY.	REV.
6	50215	HHCS M10-1.50X020 08 ZP F	16	
5	50006	WSHR M10 ZP NORDLOCK	16	
4	27332	LOWER MAST WEAR PAD	8	A
3	27331	MAST WEAR PAD	8	A
2	27061	OUTER MAST WELDMENT	1	E
1	27050	INNER MAST WELDMENT	1	E

<p>TOLERANCE UNLESS OTHERWISE SPECIFIED DIMENSIONS ARE IN INCHES</p> <p>3-PLACES (XXX) ± .015 2-PLACES (XX) ± .01 1-PLACE (X) ± .03 RADIUS DIM ± .03 HOLE DIM ± .005 ANGLE ± 1°</p> <p>INTERPRET GEOMETRIC TOLERANCING PER: ASME Y14.5</p>		<p>MATERIAL</p> <p>27333</p>		<p>FINISH</p> <p>579.91 LBS</p>		<p>SCALE</p> <p>1:16</p>		<p>SHEET</p> <p>1 OF 1</p>		<p>IBZ USED ON</p>		<p>SIZE PART NO.</p> <p>D 27333</p>		<p>REV</p> <p>A</p>	
---	--	-------------------------------------	--	--	--	---------------------------------	--	-----------------------------------	--	---------------------------	--	--	--	----------------------------	--

PROPRIETARY AND CONFIDENTIAL
 THE INFORMATION CONTAINED ON THIS DOCUMENT IS THE CONFIDENTIAL PROPERTY OF MEC AERIAL WORK PLATFORMS. DO NOT DISCLOSE, COPY, REPRODUCE, OR TRANSMIT WITHOUT WRITTEN AUTHORIZATION FROM MEC AERIAL WORK PLATFORMS.



MEC AERIAL WORK PLATFORMS
 1401 S. Modesto Ave.
 Kerman, CA 93630
 PH:539.842.1500 FX:539.842.1510

D 27333 A

REV.	ECN#	DRAWING REVISION RECORD	APPROVED DR/DSG/MFG	DATE
A		RELEASE FOR PROTOTYPE	MT	08/14/2012
B		ADDED 27382; 27383; 93066	MT	11/05/2013
C		ADDED 50118; 50451; 50452; 50453	MT	11/05/2013

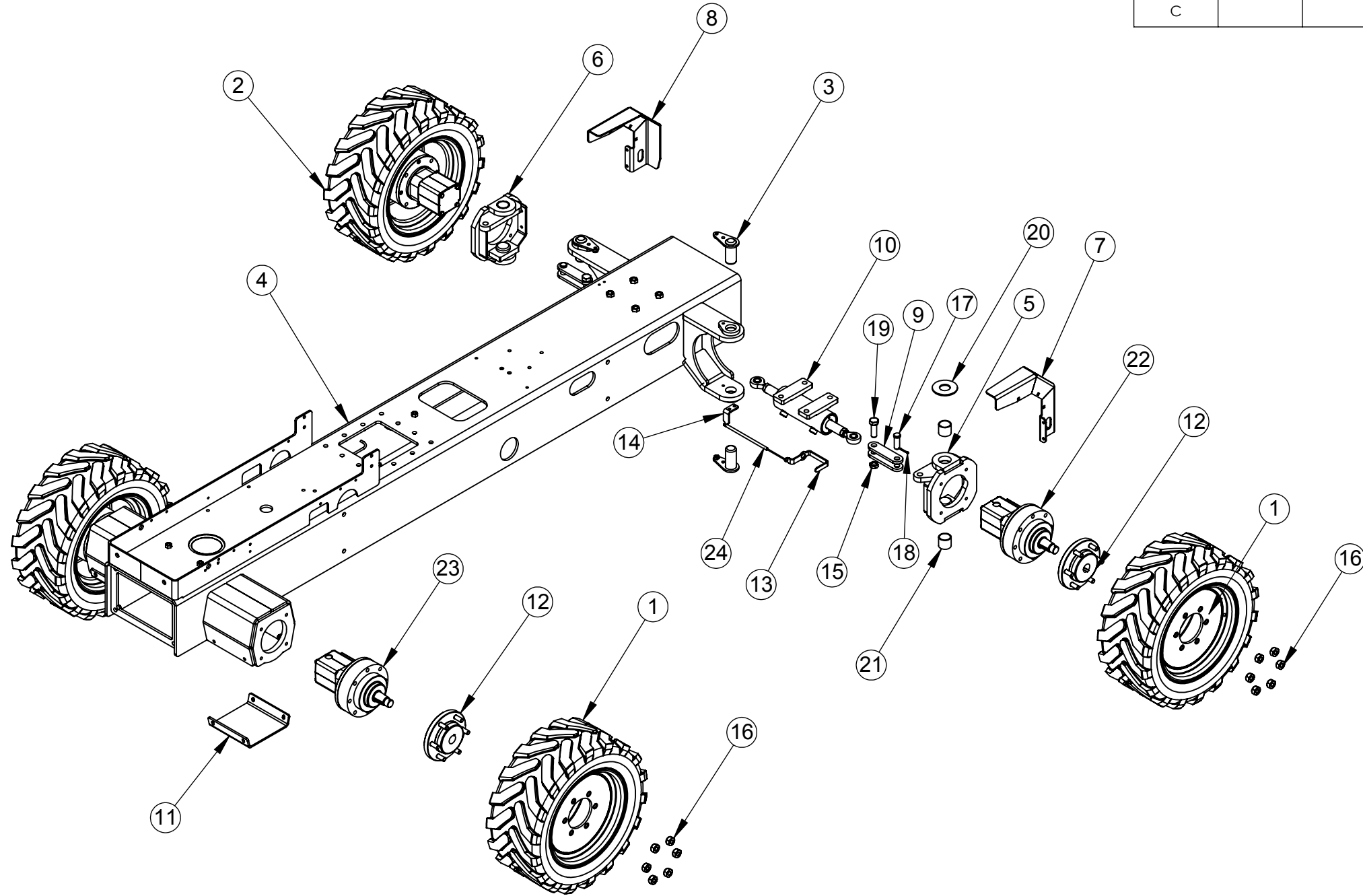

ITEM NO.	PART NUMBER	DESCRIPTION	QTY.
1	26010	BLACK WHEEL ASSY RH AIR	2
2	26031	BLACK WHEEL ASSY LH AIR	2
3	27212	KING PIN WELDMENT	4
4	27352	CHASSIS WELDMENT	1
5	27359	STEERING YOKE 1	1
6	27360	STEERING YOKE 2	1
7	27361	HOSE GUARD RH WELDMENT	1
8	27362	HOSE GUARD LH WELDMENT	1
9	27363	PITTMAN LINK	4
10	27365	STEER CYLINDER	1
11	27373	REAR MOTOR COVER	2
12	27375	HUB ADAPTOR ASSEMBLY	4
13	27382	STEER SENSOR BRACKET FORMING	1
14	27383	STEERING SENSOR MOUNT WELDMENT	1
15	50118	NNYL 03/04-10 08 ZP SHORT	2
16	50365	NLUG 09/16-18 08 ZP HEX LUG NUT	24
17	50451	PCLV 0.750X2.00 ZP STL	2
18	50452	COTTER PIN, 1/8" X 1.25"	2
19	50453	HHCS 03/04-10X02.25 05 ZP	2
20	92341	1.51"X3.5"X3/16" THRUST WASHER	2
21	92360	1.50 X 1.75 X 1.50+/-0.01" POLYGON BEARING	4
22	92988	WHITE MOTOR/BRAKE 315 400 W81 31 AAAAA	2
23	92989	WHITE MOTOR/BRAKE 315 400 W21 31 AAAAA	2
24	93066	MEASUREMENT SPECIALTIES MLP-150 STEERING POSITION SENSOR	1

NOTES: (UNLESS OTHERWISE SPECIFIED)

- 1. BREAK SHARP EDGES

TOLERANCE UNLESS OTHERWISE SPECIFIED DIMENSIONS ARE IN INCHES	
3-PLACE (.XXX)	± .015
2-PLACE (.XX)	± .03
1-PLACE (.X)	± .1
RADIUS DIM.	± .03
HOLE DIAM.	± .005
ANGLE	± 1°

CHASSIS ASSEMBLY	
TITLE:	
MATERIAL	27364 IBC MKII
DRAWING NUMBER USED ON	
FINISH	WEIGHT 1229.39 LBS
SCALE 1:18	
SHEET 1 OF 1	



MEC AERIAL WORK PLATFORMS
 1401 S. MADERA AVE
 KERMAN, CA 93630
 PH:877.632.5438 OR 559.842.1500 FX:559.842.1520

PROPRIETARY AND CONFIDENTIAL
 THE INFORMATION CONTAINED ON THIS DOCUMENT IS THE CONFIDENTIAL PROPERTY OF MEC AERIAL WORK PLATFORMS. DO NOT DISCLOSE, COPY, OR REPRODUCE WITHOUT WRITTEN AUTHORIZATION FROM MEC AERIAL WORK PLATFORMS.

SIZE	PART NO.	REV
B	27364	C

REV.	ECN#	DRAWING REVISION RECORD	APPROVED DR/DSG/MFG	DATE
A		RELEASE FOR PROTOTYPE	MT	11/07/2013

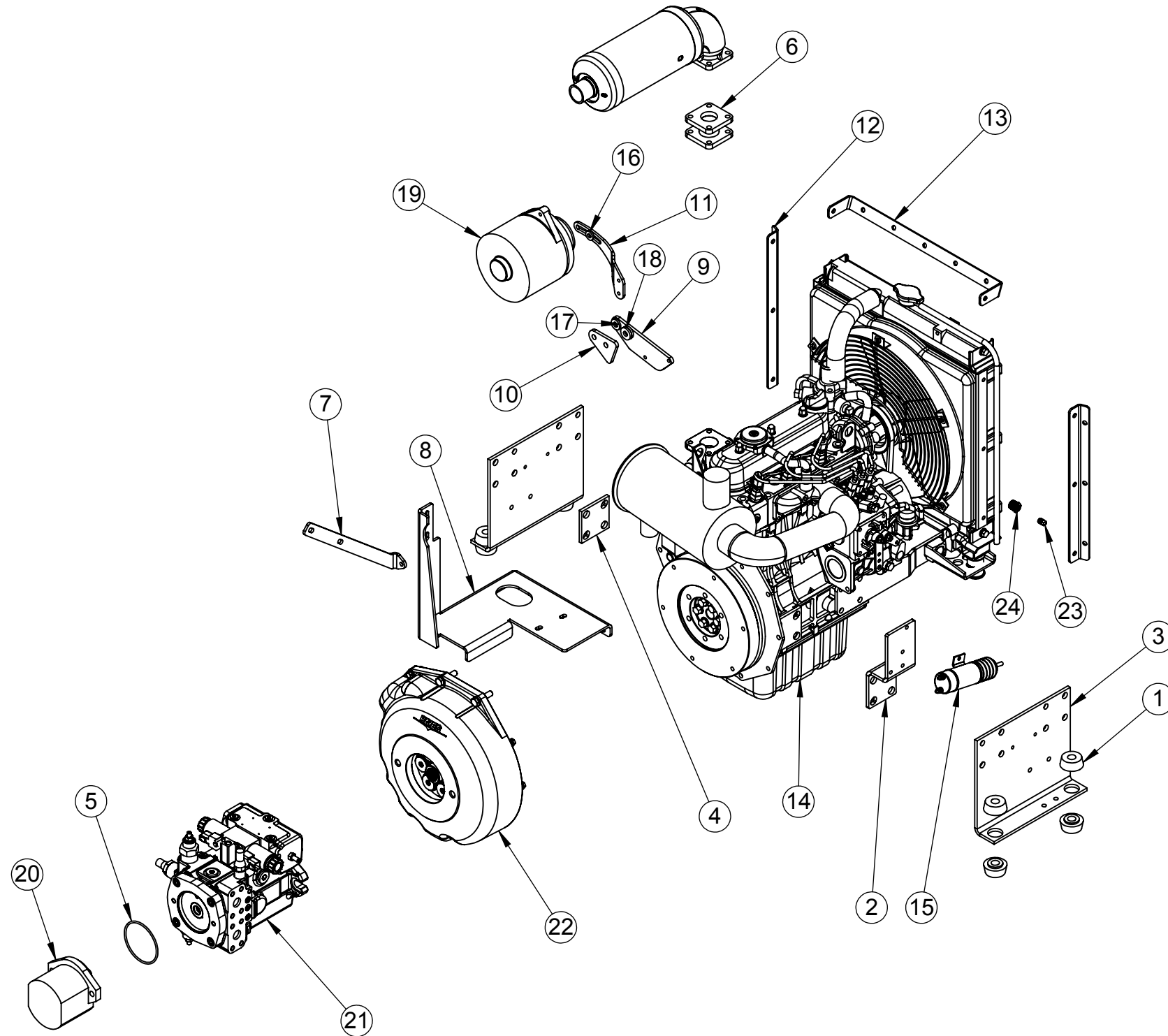

ITEM NO.	PART NUMBER	DESCRIPTION	QTY.
1	7736	INSULATOR, RUBBER	8
2	16207	MOUNT SOLENOID D905	1
3	16209	ANGEL, MOUNT (DSL)	2
4	16210	SPACER, ENGINE	1
5	17971	SAE A MOUNT PUMP O-RING	1
6	27049	MUFFLER SUPPORT WELDMENT	1
7	27221	MUFFLER STIFFENING FORMING	1
8	27226	MUFFLER BRACKET WELDMENT	1
9	27258	FRONT ALTERNATOR BRACKET	1
10	27259	REAR ALTERNATOR BRACKET	1
11	27260	TOP ALTERNATOR BRACKET	1
12	27265	RUBBER FLAP SIDE MOUNT FORMING	2
13	27266	TOP AIRFLOW BRACKET	1
14	91429	D1105 ENGINE ASSEMBLY	1
15	91589	THROTTLE SOLENOID DIESEL ENGINE; TROMBETTA	1
16	92369	WSHR 11/32"X3/4"X.14"	1
17	92370	13/32"X7/8"X.14" WSHR	1
18	92371	13/32"X1"X.175" WSHR	2
19	92382	BOSCH 120AMP ALTERNATOR	1
20	92991	5.5CC REXROTH PUMP AZPF 12 055 R R R12 MB	1
21	93339	REXROTH 28CC PUMP AA10VG28EP11/10R-NSC66F015DP	1
22	93470	D1105 SAE B-B COUPLER (15T SPLINE) 952317	1
23	93486	COOLANT HIGH TEMP SWITCH D1105	1
24	93487	1/8" FEMALE NPT to 3/8" MALE NPT ADAPTER FOR 93486	1

NOTES: (UNLESS OTHERWISE SPECIFIED)

- 1. BREAK SHARP EDGES

PROPRIETARY AND CONFIDENTIAL
 THE INFORMATION CONTAINED ON THIS DOCUMENT IS THE CONFIDENTIAL PROPERTY OF MEC AERIAL WORK PLATFORMS. DO NOT DISCLOSE, COPY, OR REPRODUCE WITHOUT WRITTEN AUTHORIZATION FROM MEC AERIAL WORK PLATFORMS.

TOLERANCE UNLESS OTHERWISE SPECIFIED DIMENSIONS ARE IN INCHES	
3-PLACE (.XXX)	± .015
2-PLACE (.XX)	± .03
1-PLACE (.X)	± .1
RADIUS DIM	± .03
HOLE DIAM.	± .005
ANGLE	± 1°

UNION PACIFIC IBC ENGINE ASSEMBLY



MEC AERIAL WORK PLATFORMS
 1401 S. MADERA AVE
 KERMAN, CALIFORNIA 93630
 PH:877.632.5438 OR 559.842.1500 FX:559.842.1520

TITLE:		27401		IBC	
MATERIAL		DRAWING NUMBER		USED ON	
FINISH		WEIGHT 307.56 LBS		SCALE 1:10	
SIZE		SHEET 1 OF 1		REV A	
PART NO. 27401		DRAWING NUMBER		SHEET 1 OF 1	

REV.	ECN#	DRAWING REVISION RECORD	APPROVED DR/DSG/MFG	DATE
A		RELEASE FOR PROTOTYPE	MT	11/05/2013

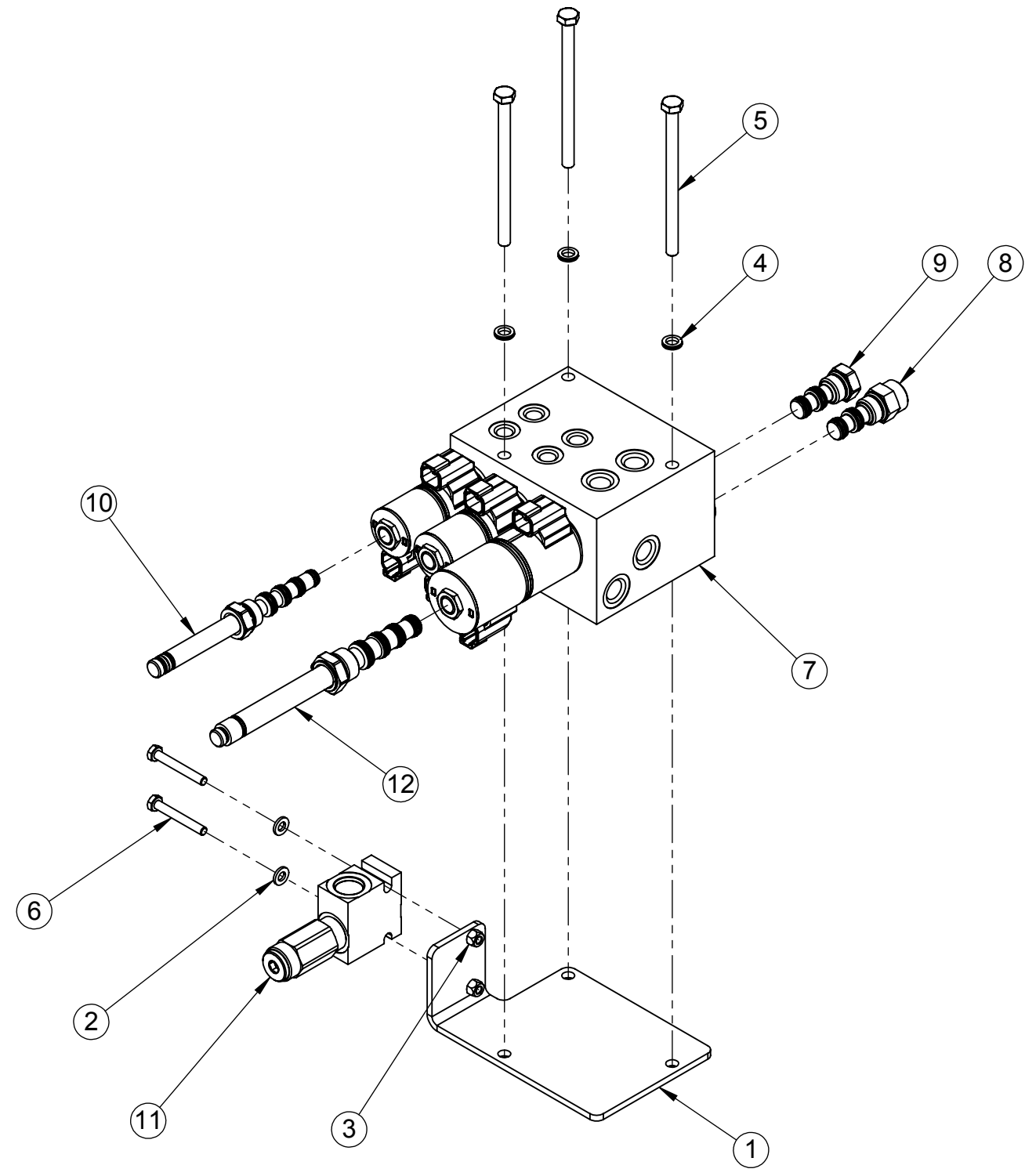

ITEM NO.	PART NUMBER	DESCRIPTION	QTY.
1	27386	MANIFOLD SPACER FORMING	1
2	50000	WSHR M06 ZP STANDARD FLAT	2
3	50047	NNYL M06X1.00 08 ZP NYLOCK	2
4	50200	M08 NORDLOCK WASHER	3
5	50268	HHCS M08-1.25X120 08 ZP P	3
6	50294	HHCS M06-1.00X45 08 ZP P	2
7	92082	PLATFORM FUNCTION MANIFOLD	1
8	92669	HYDRAFORCE EPFR58-35-0-N-150	1
9	92750	HYDRAFORCE CP08-3A-N	1
10	92811	HYDRAFORCE SV08-58C-0-N-00	1
11	93068	HYDRAFORCE RV08-22H-6T-N-35/30	1
12	93069	HYDRAFORCE SP10-57C-0-N-00	1

NOTES: (UNLESS OTHERWISE SPECIFIED)

- LUBRICATE O-RINGS WITH HYDRAULIC FLUID BEFORE INSTALLING VALVES
- TORQUE -10 SIZE VALVE TO 24 LB-FT
- TORQUE -08 SIZE VALVES TO 19 LB-FT

TOLERANCE UNLESS OTHERWISE SPECIFIED DIMENSIONS ARE IN INCHES

3-PLACE (.XXX)	± .015
2-PLACE (.XX)	± .03
1-PLACE (.X)	± .1
RADIUS DIM.	± .03
HOLE DIAM.	± .005
ANGLE	± 1°

INTERPRET GEOMETRIC TOLERANCING PER: ASME Y14.5

IBC FUNCTION MANIFOLD ASSEMBLY

TITLE:



MEC AERIAL WORK PLATFORMS
 1401 S. MADERA AVE
 KERMAN, CALIFORNIA 93630
 PH:877.632.5438 OR 559.842.1500 FX:559.842.1520

PROPRIETARY AND CONFIDENTIAL

THE INFORMATION CONTAINED ON THIS DOCUMENT IS THE CONFIDENTIAL PROPERTY OF MEC AERIAL WORK PLATFORMS. DO NOT DISCLOSE, COPY, OR REPRODUCE WITHOUT WRITTEN AUTHORIZATION FROM MEC AERIAL WORK PLATFORMS.

MATERIAL	84288	IBC
FINISH	WEIGHT 16.32 LBS	SCALE 1:4
	DRAWING NUMBER	SHEET 1 OF 1
SIZE	PART NO. 84288	REV A

REV.	ECN#	DRAWING REVISION RECORD	APPROVED DR/DSG/MFG	DATE
A		RELEASE FOR PROTOTYPE	MT	11/07/2013

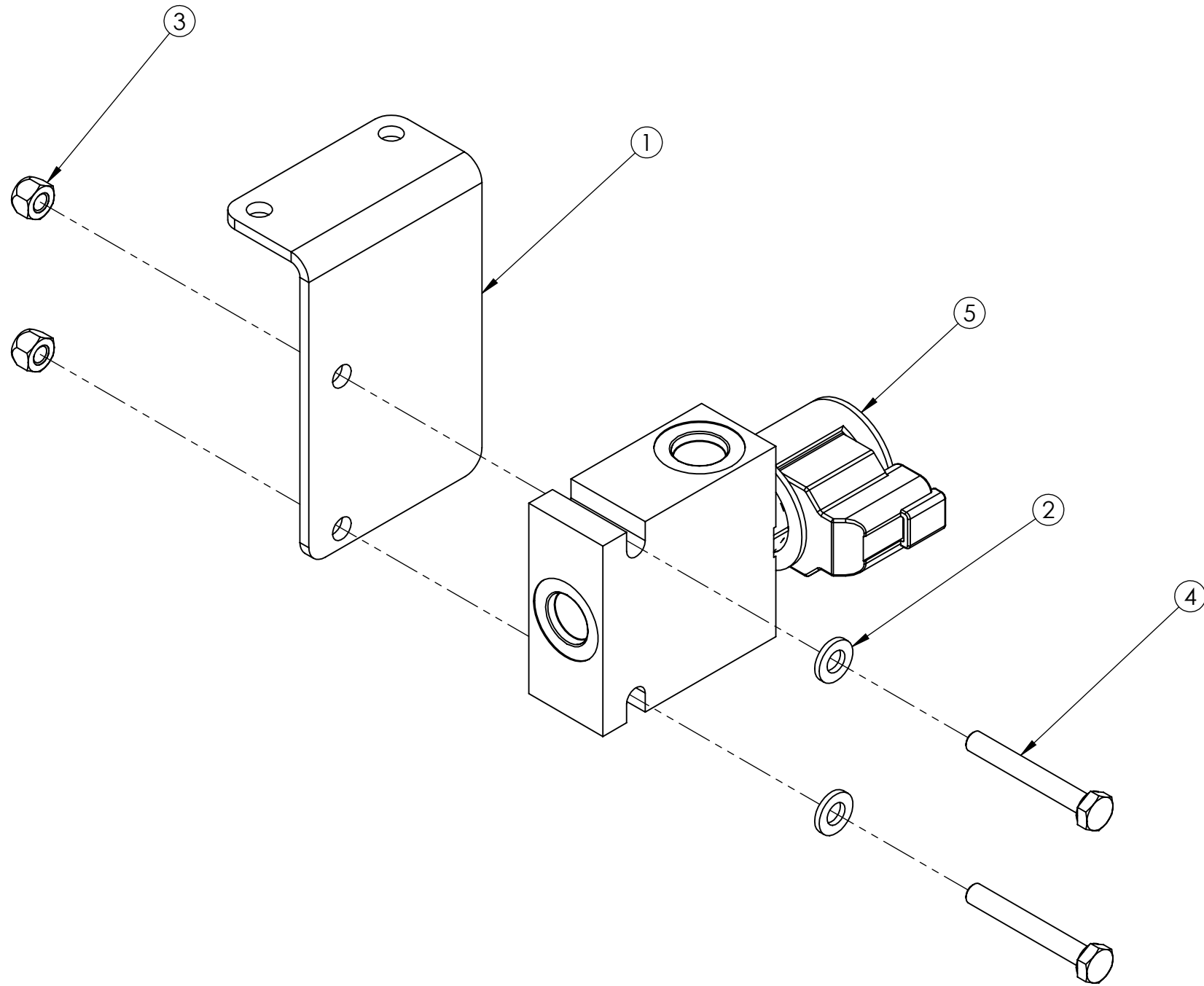

ITEM NO.	PART NUMBER	DESCRIPTION	QTY.
1	27384	BRK DUMP VALVE FORMING	1
2	50000	WSHR M06 ZP STANDARD FLAT	2
3	50047	NNYL M06X1.00 08 ZP NYLOCK	2
4	50294	HHCS M06-1.00X45 08 ZP P	2
5	93067	HYDRAFORCE SV08-30-6T-N-12ER	1

NOTES: (UNLESS OTHERWISE SPECIFIED)

- 1. BREAK SHARP EDGES

TOLERANCE UNLESS OTHERWISE SPECIFIED DIMENSIONS ARE IN INCHES	
3-PLACE (.XXX)	± .015
2-PLACE (.XX)	± .03
1-PLACE (.X)	± .1
RADIUS DIM	± .03
HOLE DIAM.	± .005
ANGLE	± 1°

INTERPRET GEOMETRIC TOLERANCING PER: ASME Y14.5

IBC BRAKE DUMP VALVE ASSEMBLY

TITLE:

MATERIAL

84290

IBC USED ON

FINISH

WEIGHT 2.02 LBS

SCALE 2:3

SHEET 1 OF 1



MEC AERIAL WORK PLATFORMS
1401 S. MADERA AVE
KERMAN, CALIFORNIA 93630
PH:877.632.5438 OR 559.842.1500 FX:559.842.1520

SIZE	PART NO.	REV
B	84290	A

PROPRIETARY AND CONFIDENTIAL
THE INFORMATION CONTAINED ON THIS DOCUMENT IS THE CONFIDENTIAL PROPERTY OF MEC AERIAL WORK PLATFORMS. DO NOT DISCLOSE, COPY, OR REPRODUCE WITHOUT WRITTEN AUTHORIZATION FROM MEC AERIAL WORK PLATFORMS.

REV.	ECN#	DRAWING REVISION RECORD	APPROVED DR/DSG/MFG	DATE
A		RELEASE FOR PTOTOTYPE	MT	11/07/2013

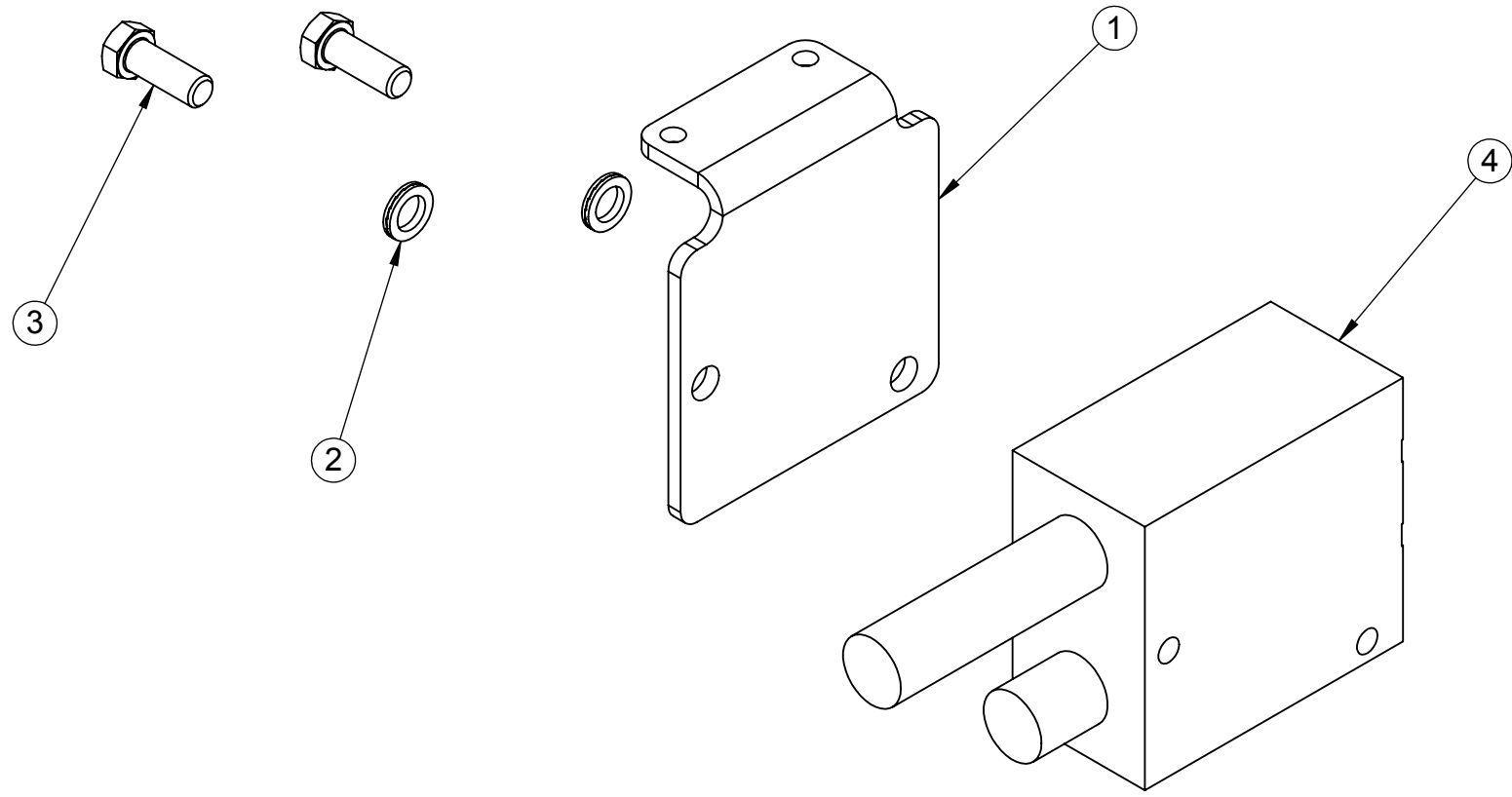

ITEM NO.	PART NUMBER	DESCRIPTION	QTY.
1	27385	BRAKE RELEASE FORMING	1
2	50006	WSHR M10 ZP NORDLOCK	2
3	50219	HHCS 03/08-16X00.75 05 ZP	2
4	93049	WHITE BRAKE RELEASE MANIFOLD 960020A10AAAA	1

NOTES: (UNLESS OTHERWISE SPECIFIED)

- 1. BREAK SHARP EDGES

PROPRIETARY AND CONFIDENTIAL
 THE INFORMATION CONTAINED ON THIS DOCUMENT IS THE CONFIDENTIAL PROPERTY OF MEC AERIAL WORK PLATFORMS. DO NOT DISCLOSE, COPY, OR REPRODUCE WITHOUT WRITTEN AUTHORIZATION FROM MEC AERIAL WORK PLATFORMS.

TOLERANCE UNLESS OTHERWISE SPECIFIED DIMENSIONS ARE IN INCHES 3-PLACE (.XXX) ± .015 2-PLACE (.XX) ± .03 1-PLACE (.X) ± .1 RADIUS DIM ± .03 HOLE DIAM. ± .005 ANGLE ± 1°		IBC BRAKE RELEASE MANIFOLD ASSEMBLY		 MEC AERIAL WORK PLATFORMS 1401 S. MADERA AVE KERMAN, CALIFORNIA 93630 PH:877.632.5438 OR 559.842.1500 FX:559.842.1520
INTERPRET GEOMETRIC TOLERANCING PER: ASME Y14.5		TITLE:		
MATERIAL		84289 DRAWING NUMBER	IBC USED ON	SIZE PART NO.
FINISH		WEIGHT 9.21 LBS	SCALE 1:2	SHEET 1 OF 1
		B	84289	REV A