

Hydraulic Schematic

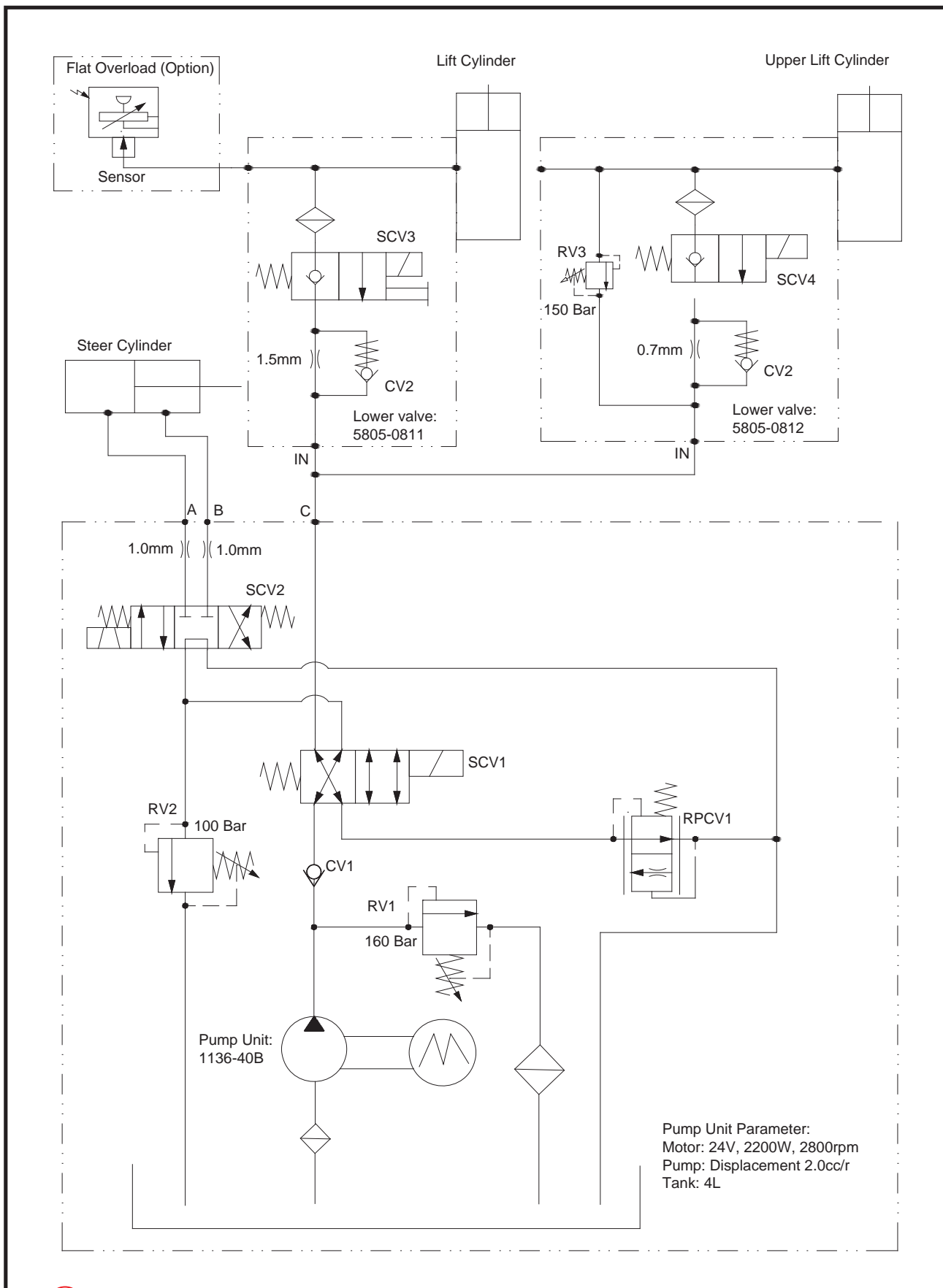

ILLUSTRATION No. Art_5537

Micro 19

Hydraulic Schematic



Electrical Schematic

