



Operator's Manual

Micro19AE

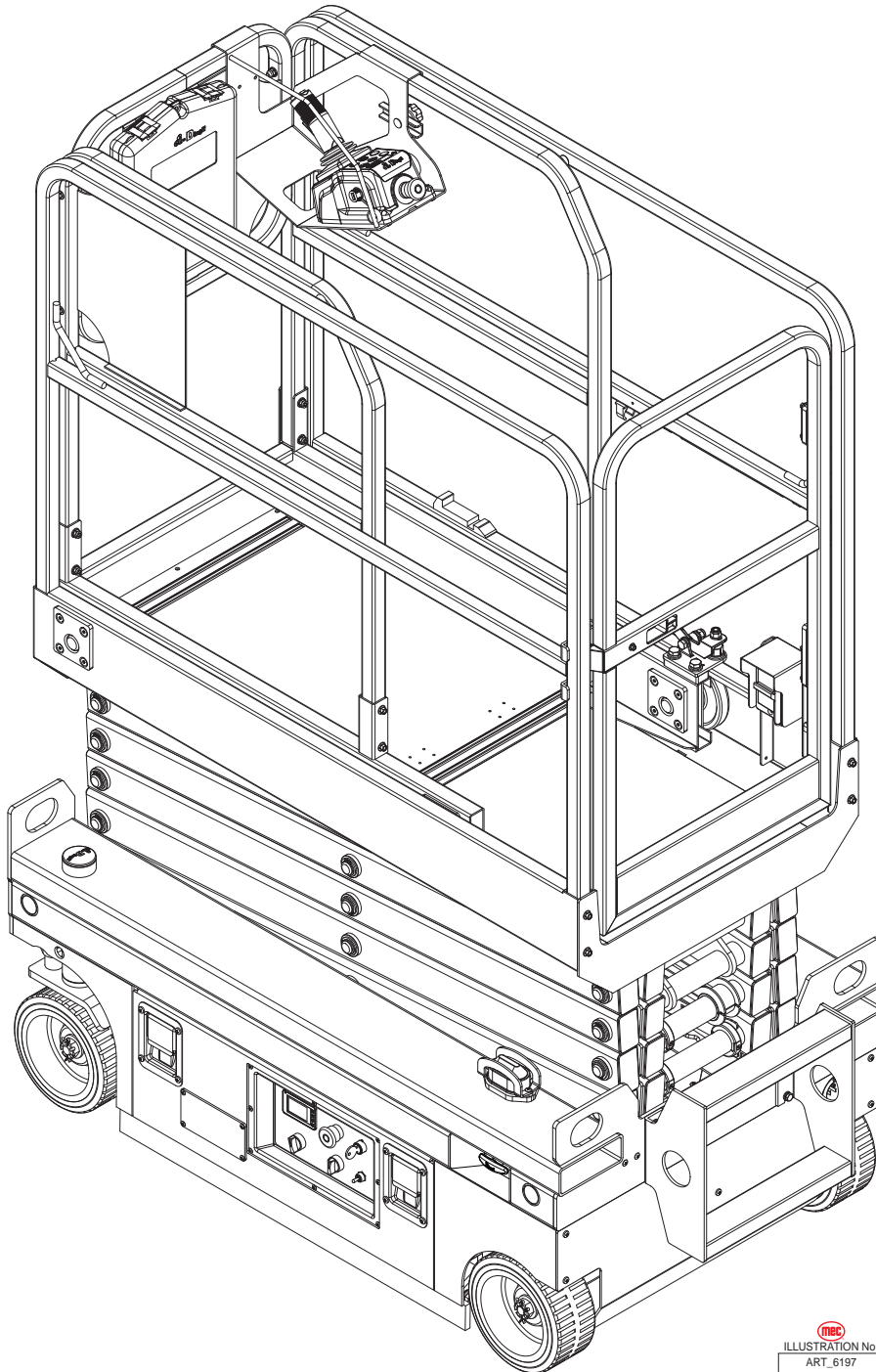

 ILLUSTRATION No.
ART_6197

Meets requirements of ANSI A92.20-2020 and CSA B354.6-2019.
Serial Number Range 1890026 - Up

Part # 96683
September 2024

Revision History

Date	Reason for Update
September 2024	New Release



MEC Aerial Work Platforms

1401 S. Madera Avenue, Kerman, CA 93630 USA
Toll Free: 1-877-632-5438
Phone: 1-559-842-1500
Fax: 1-559-842-1520
info@MECawp.com
www.MECawp.com



Table of Contents

Section 1 - Introduction	1
<i>Introduction</i>	1
Section 2 - Safety	2
<i>Safety</i>	2
<i>Safety Alert Symbols & Fall Protection</i>	3
Section 3 - Specifications	4
<i>Specifications</i>	4
Section 4 - Hazards	5
<i>Electrocution Hazard</i>	5
<i>Energized Conductor Contact Hazard</i>	6
<i>Tip-over Hazards</i>	8
<i>Fall & Collision Hazards</i>	10
<i>Additional Safety Hazards</i>	12
Section 5 - Components and Controls	13
<i>Component Locations</i>	13
<i>Platform Controls</i>	14
<i>Lower Controls</i>	15
Section 6 - Workplace Inspection	16
<i>Workplace Inspection</i>	16
Section 7 - Operating Instructions and Function Tests	17
<i>Functions Tests</i>	17
<i>Operating Instructions</i>	22
Section 8 - Battery Charging	27
<i>Battery Charging</i>	27
Section 9 - Maintenance	28
<i>Maintenance</i>	28
<i>Pre-Start Inspection Checklist</i>	30
<i>Frequent Inspection Checklist</i>	31
<i>Maintenance Inspection Report</i>	32
Section 10 - Decals	33
<i>Decals</i>	33
<i>Serial Plate</i>	35
Section 11 - Troubleshooting	36
<i>Troubleshooting</i>	36
Section 12 - Transporting and Lifting Instruction	37
<i>Transport and Lifting Instructions</i>	37

Section 13 - Machine Storage 40
Machine Storage 40



Introduction

This Operator's Manual has been designed to provide you, the owner, user or operator, with the instructions and operating procedures essential to properly and safely operate your MEC Aerial Work Platform for positioning personnel, along with their necessary tools and materials, to overhead work locations.

This Operator's Manual and other manuals provided by MEC on the machine must be read and understood prior to operating your MEC Aerial Work Platform. The operator should not accept operating responsibility until he/she has read and understands the operator's manual as well as having operated the MEC Aerial Work Platform under supervision of an authorized, trained and qualified operator.



It is essential that the operator of the aerial work platform is not alone at the workplace during operation.

Modifications of this machine from the original design and specifications without written permission from MEC are strictly forbidden. A modification may compromise the safety of the machine, subjecting the platform occupants and personal around the machine to serious injury or death.

Your MEC Aerial Work Platform has been designed, built, and tested to provide safe, dependable service. Only authorized, trained and qualified personnel shall be allowed to operate or service the machine.

MEC, as manufacturer, has no direct control over machine application and operation. Proper safety practices are the responsibility of the owner, user and operator.

If there is a question on application and/or operation contact:



MEC Aerial Work Platforms

1401 S. Madera Avenue, Kerman, CA 93630 USA

Toll Free: 1-877-632-5438

Phone: 1-559-842-1500

Fax: 1-559-842-1520

info@MECawp.com

www.MECawp.com

Safety

DO NOT operate this machine until you have read and understood this manual, have performed the Workplace Inspection, Pre-Start Inspection and Routine Maintenance, and have completed all the test operations detailed in the Operating Instructions section.

Failure to read, understand and follow all safety rules, warnings, and instructions could result in serious injury or death. For your safety and the safety of those around you, you must operate your machine as instructed in this manual.

MEC designs aerial work platforms to safely and reliably position personnel, along with their necessary tools and materials, at overhead work locations. The owner/user/operator of the machine should not accept responsibility for the operation of the machine unless properly trained.

ANSI and other applicable standards identify requirements of all parties who may be involved with self-propelled elevating work platforms. The Manual of Responsibilities is considered a part of this machine and can be found in the manual compartment, located at the platform control station. To ensure safe use of machine, inspections and training specified in ANSI/SIA A92.22 & A92.24 must be performed at designated intervals as prescribed.



This product can expose you to chemicals known to the State of California to cause cancer and birth defects or other reproductive harm. For more information go to www.p65warnings.ca.gov.

Safety Alert Symbols & Fall Protection

MEC manuals and decals use symbols, colors and signal words to help you recognize important safety, operation and maintenance information.



RED and the word **DANGER** – Indicates an imminently hazardous situation which, if not avoided, will result in death or serious injury.



ORANGE and the word **WARNING** – Indicates a potentially hazardous situation which, if not avoided, could result in death or serious injury.



YELLOW with alert symbol and the word **CAUTION** – Indicates a potentially hazardous situation which, if not avoided, may result in minor or moderate injury.



YELLOW without alert symbol and the word **CAUTION** – Indicates a potentially hazardous situation which, if not avoided, may result in property damage.



GREEN and the word **NOTICE** – Indicates operation or maintenance information.

Fall Protection

Operators must comply with employer, job site and governmental rules regarding the use of personal protective equipment.

If required by your employer or job site, use personal fall protection equipment (PFPE) when operating this machine.

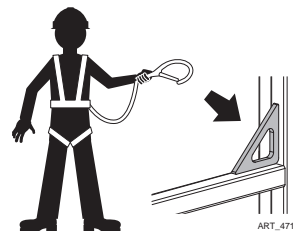

All personal fall protection equipment (PFPE) must comply with applicable governmental regulations, and must be inspected and used in accordance with the personal fall protection equipment (PFPE) manufacturer's instructions.

Fall restraint or fall arrest must be properly attached to a designated anchorage point when driving or operating the machine. Attach only one fall restraint or fall arrest to each anchorage point.

Specifications

Height, Working Maximum*	Indoors	24.9ft	7.6m
	Outdoors	21.7ft	6.6m
Height, Platform Maximum	Indoors	18.4ft	5.6m
	Outdoors	15.1ft	4.6m
Height, Stowed Maximum		78.3in	1.99m
Width		31.9in	0.81m
Length, Platform	Deck Retracted	59.8in	1.52m
	Deck Extended	83.5in	2.12m
Platform Dimensions (Length x Width)		53.9x27.6in	1.37x0.7m
Platform Maximum Capacity		500lbs	227kg
Platform Extension Deck Length		23.6in	0.6m
Platform Extension Deck Capacity		250lbs	113kg
Maximum Wind Speed		0mph	0m/s
Wheelbase		44.5in	1.13m
Turning Radius	Outside	63in	1.60m
	Inside	17.7in	0.45m
Ground Clearance Pothole	Platform Stowed	2.4in	6cm
	Platform Raised	0.6in	1.5cm
Maximum Occupants	Indoors	2 Person	
	Outdoors	1 Person	
Manual Force	Indoors	90lbs	400N
	Outdoors	45lbs	200N
Weight** (Unloaded)		2,955lbs	1,340kg
Power Source		2 Batteries, 12Volts 115Ah	
Power System Voltage		24Volts DC	
Tire Size		9x4in	Φ230x100mm
Maximum Slope Rating			
Slope Rating, Stowed Position		25% (14°)	
Side Slope Rating, Stowed Position		25% (14°)	
Chassis Slope		1.5 Side, 3.0 Inline	
Drive Speeds			
Platform Stowed, Maximum		2.5mph	4.0km/h
Platform Raised, Maximum		0.4mph	0.6km/h
Floor Loading Information			
Tire Load, Maximum		1,254lbs	570kg
Tire Contact Pressure		116 psi	8.2 kg/cm ² (801 kPa)
Occupied Floor Pressure		1,168 psf	11,77 kg/m ² (11.5 kPa)
Meets requirements of ANSI A92.20-2020 and CSA B354.6-2019.			
*Working Height adds 6 feet (2 meters) to platform height.			
**Weight may increase with certain options.			

Electrocution Hazard

ELECTROCUTION HAZARD! THIS MACHINE IS NOT INSULATED!

DEATH OR SERIOUS INJURY will result from contact with or inadequate clearance from any electrically charged conductor.



You must maintain a **CLEARANCE OF AT LEAST 10 FEET (3.05 meters)** between any part of the machine, or its load, and any electrical line or apparatus carrying over 300 Volts up to 50,000 Volts. One foot (30.5 centimeters) additional clearance is required for every additional 30,000 Volts.

Observe Minimum Safe Approach Distance.

This machine is not electrically insulated and will not provide protection from contact with or proximity to electrical current.

Maintain safe distances from electrical power lines and apparatus in accordance with applicable government regulations and the following chart:

Voltage	Minimum Safe Approach Distance	
	Feet	Meters
Phase to Phase		
0 to 300 Volts	Avoid Contact	
Over 300V to 50kv	10ft	3.1m
Over 50KV to 200KV	15ft	4.6m
Over 200KV to 350KV	20ft	6.1m
Over 350KV to 500KV	25ft	7.6m
Over 500KV to 750KV	35ft	10.7m
Over 750KV to 1000KV	45ft	13.7m



Allow for platform movement, electrical line sway or sag and beware of strong or gusty winds.

Keep away from the machine if it contacts energized power lines. Personnel on the ground or in the platform must not touch or operate the machine until energized power lines are shut off.

Do not use the machine as a ground for welding.

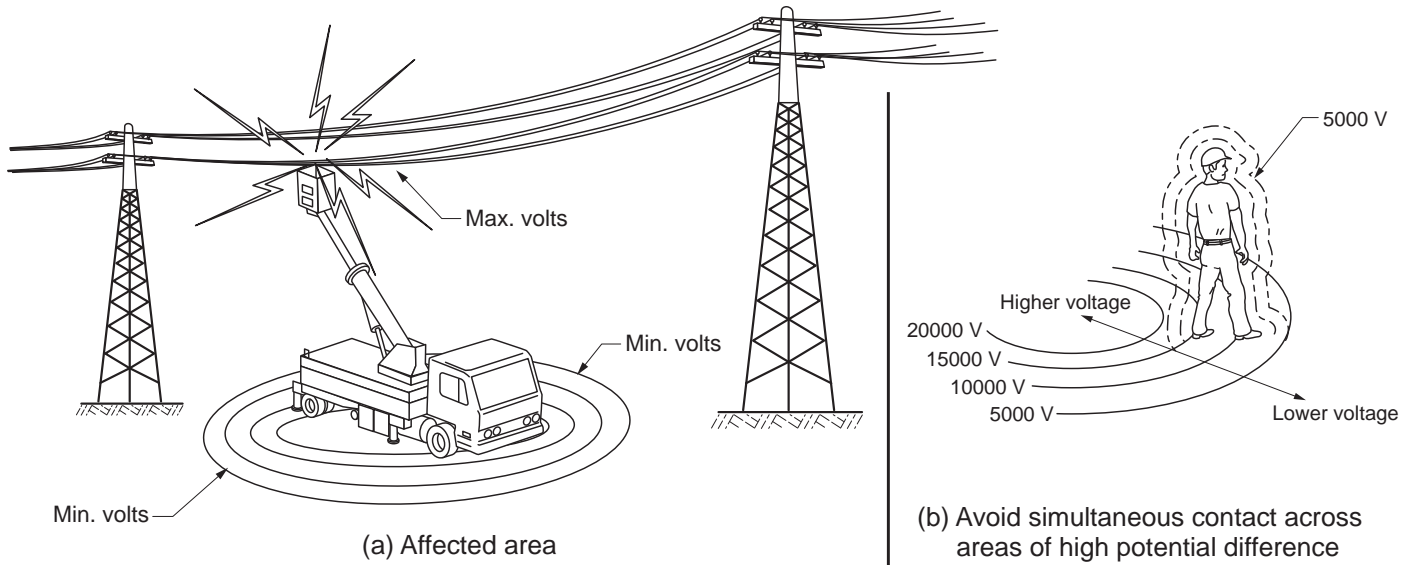

CLEARANCES FROM LIVE AERIAL CONDUCTORS

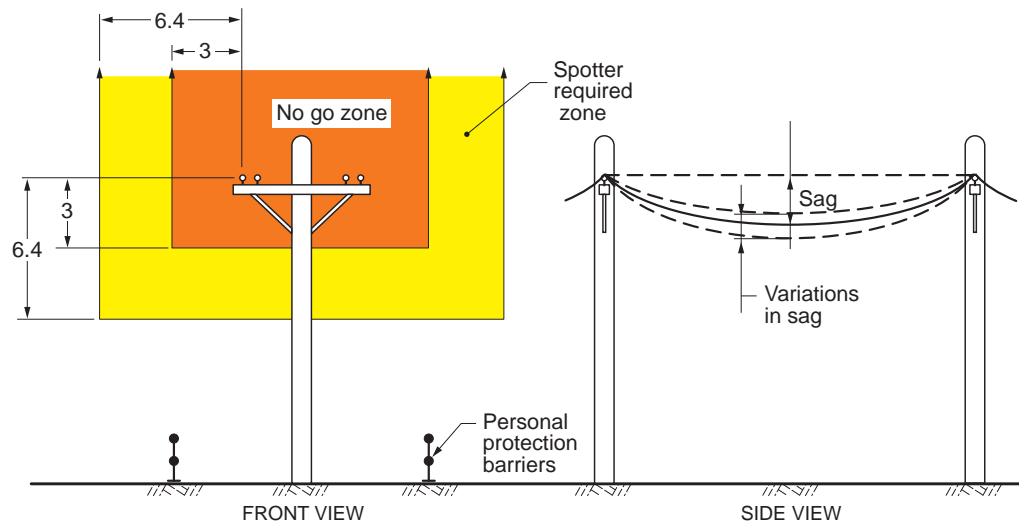

(a) Distribution lines up to and including 133 kV

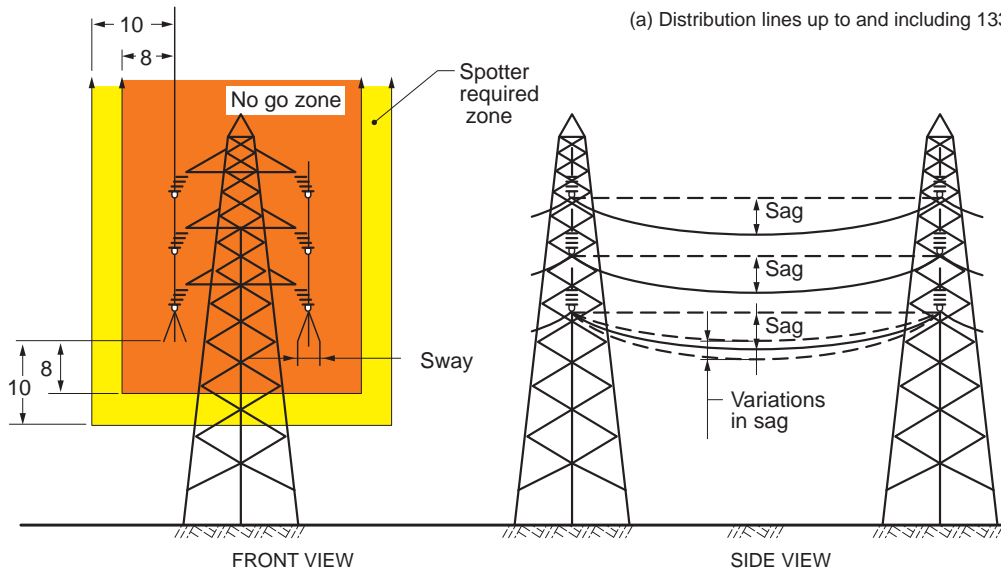

(b) Transmission lines greater than 133 kV

LEGEND

- = No shading, in the front views, indicates no proximity requirements
- = Light shading indicates spotter is required
- = Heavy shading indicates the NO GO ZONE

When working in the area of energized conductors the user shall direct and the operator shall comply with the requirements to:

- 1) Stay at least 10 feet (3.05 meters) away from power lines with any part of their body, conductive object or any part of the MEWP (Mobile Elevating Work Platform).
- 2) If work requires working nearer than 10 feet (3.05 meters), stop and consult a qualified person with respect to electrical transmission and distribution to have appropriate measures taken (such as de-energizing and grounding).
- 3) If there is a question that the power lines may carry more than 50kV, consult a qualified person with respect to electrical transmission and distribution before proceeding.
- 4) If working or approaching closer than explained above, it shall only be done by a qualified person with respect to electrical transmission and distribution. Only qualified persons may work on electric circuit parts or equipment that has not been de-energized. Such persons shall be capable of working safely on energized circuits and shall be familiar with the proper use of special precautionary techniques, personal protective equipment, insulating and shielding materials and insulated tools.

Tip-over Hazards

DO NOT exceed the maximum platform capacity. The weight of options and accessories will reduce the rated platform capacity and must be factored into the total platform load. Refer to the decals on the options.

DO NOT elevate the platform when the machine is on a surface that is soft and/or on a slope.

DO NOT elevate the platform unless the machine is on a firm, level surface.

DO NOT depend on the tilt alarm as a level indicator. STOP if the tilt alarm sounds and the red light illuminates when the platform is raised. Use extreme caution to lower the platform. Move the machine to a firm, level surface.

Driving: DO NOT drive the machine on a slope that exceeds the maximum uphill, downhill or side slope rating. Slope rating applies to machines in the stowed position.

Driving in stowed position: Use extreme care and reduce speed when driving across uneven terrain, debris, unstable or slippery surfaces, and near holes or drop-offs.

Driving with the platform elevated: DO NOT drive on or near uneven terrain, unstable surfaces, curbs, drop-offs or other hazardous conditions. DO NOT drive the machine faster than 0.4mph (0.6km/h) while elevated.

DO NOT push off or pull toward any object outside the platform. DO NOT push the machine or other objects with the platform. DO NOT contact adjacent structures with the platform.

DO NOT tie the platform to adjacent structures.

Maximum Allowable Side Force
45lbs (200N) per person

DO NOT use the platform controls to free a platform that is caught, snagged or otherwise prevented from normal motion by an adjacent structure.

DO NOT elevate the platform when wind speeds are in excess of 28mph (12.5m/s). If wind speeds exceed 28mph (12.5m/s) when the platform is elevated, carefully lower the platform and discontinue operation.

DO NOT increase the surface area of the platform (i.e. cover the rails with tarp or plywood). Increased surface area exposed to the wind will decrease machine stability.

DO NOT attach overhanging loads or use the machine as a crane. DO NOT place loads outside the platform perimeter.



Art_2828



Art_2834



Art_2833



Art_2831



Art_2832

NEVER transport tools and materials unless they are firmly secured. Secure all tools and loose materials.

NEVER alter or disable any machine components.

NEVER replace any part of the machine with items of different weight or specification.

NEVER modify or alter the work platform without written permission from MEC.

NEVER place ladders or scaffolds in the platform or against any part of the machine.

NEVER use the machine on a moving or mobile surface or vehicle.

Ensure that all tires are in good condition and lug nuts are properly torqued.

DO NOT operate the machine with the chassis trays open.

DO NOT alter or disable the limit switches or machine components that in any way affect safety and stability.

DO NOT replace items critical to machine stability with items of different weight or specification. DO NOT modify or alter this machine without prior written permission from the manufacturer.

DO NOT use batteries that weigh less than the original equipment. Each battery must weigh 72lbs (32.7kg). The batteries must weigh a minimum of 144lbs (65.4kg).

Fall & Collision Hazards

Fall Hazards

DO NOT sit, stand or climb on the platform guard rails. Maintain a firm footing on the platform floor at all times.

DO NOT exit the platform when elevated. DO NOT climb down from the platform when elevated.

Keep the platform floor clear of debris.

DO NOT fasten a fall restraint lanyard to an adjacent structure.

Ensure that the platform entry is properly closed and secured before operating the machine.

Ensure that the guard rails are properly installed and in good condition before operating the machine.

Operators must comply with employer and job site rules and governmental regulations regarding the use of personal protective equipment.



Art_2826



Art_2825

Collision Hazards

Check path before moving for equipment, materials or other obstructions.

Check path before moving for overhead obstructions.

Check path before moving for crushing hazards when holding the platform rail.

Be aware of limited sight distance and blind spots when driving or operating.

Be aware of extended platform position(s) when moving the machine.

Observe and use color-coded direction arrows on the platform controls and platform decal plate for drive and steer functions.

Reduce travel speed when moving the machine on slopes, when near personnel and obstacles, or when surface conditions are wet, slippery or otherwise limiting.

DO NOT operate in the path of any crane unless the controls of the crane have been locked out and/or precautions have been taken to prevent any possible collision.

Stunt driving and horseplay are PROHIBITED.

Watch for personnel and obstructions below the platform when lowering the platform.



Art_2835



Art_2829



Art_2827

Keep hands and limbs out of scissors.

Use common sense and planning when operating the machine with the controller from the ground. Maintain safe distances between the operator, the machine and fixed objects.

Additional Safety Hazards

Explosion and Fire Hazards

- DO NOT operate the machine in hazardous locations or locations where potentially flammable or explosive gases or particles may be present.

Damaged Machine Hazards

- Conduct a thorough pre-start inspection of the machine and test all functions before each work shift to check for damage, malfunction and unauthorized modification. Tag and remove a damaged, malfunctioning or modified machine from service. DO NOT use a damaged, malfunctioning or modified machine.
- Routine maintenance must be performed by the operator before each work shift. Scheduled maintenance must be performed by a qualified service technician at scheduled intervals. Tag and remove from service any machine that has not had scheduled preventative maintenance performed.
- Check that all safety and instructional decals are in place and undamaged.
- Check that the operator's, safety and responsibilities manuals are present in the storage container located in the platform. All manuals must be complete, undamaged and readable.

Bodily Injury Hazards

- All compartments must remain closed and secure during machine operation. Improper contact with components under any cover will cause serious injury. Only trained maintenance personnel should access compartments. The operator should only access a compartment when performing pre-operation inspection.

Weld Line to Platform Safety (if equipped)

- Read, understand and follow all warnings and instructions provided with the welding power unit.
- Do not connect weld leads or cables unless the welding power unit is turned off at the platform controls.
- DO NOT operate unless the weld cables are properly connected.
- DO NOT connect the ground lead to the platform.

Battery Safety - Burn Hazards

- Batteries contain acid. Always wear protective clothing and eye wear when working with batteries.
- Avoid spilling or contacting battery acid. Neutralize battery acid spills with baking soda and water.

Battery Safety - Explosion Hazard

- Keep sparks, flame and lighted tobacco away from batteries. Batteries emit explosive gas. The battery tray should remain open during the entire charging cycle.

Battery Safety - Electrocution Hazard

- Avoid contact with electrical terminals.

Component Locations

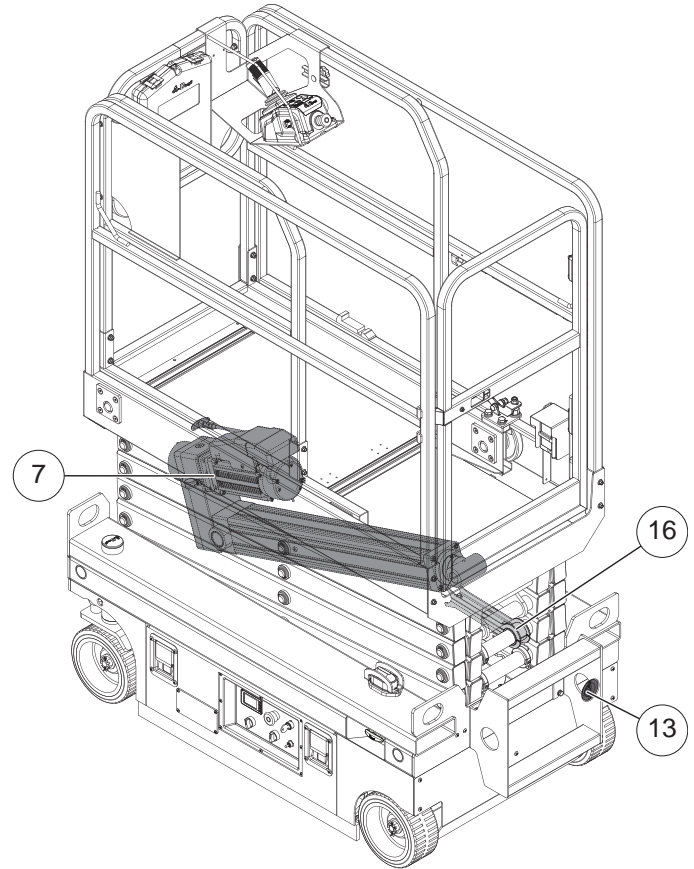
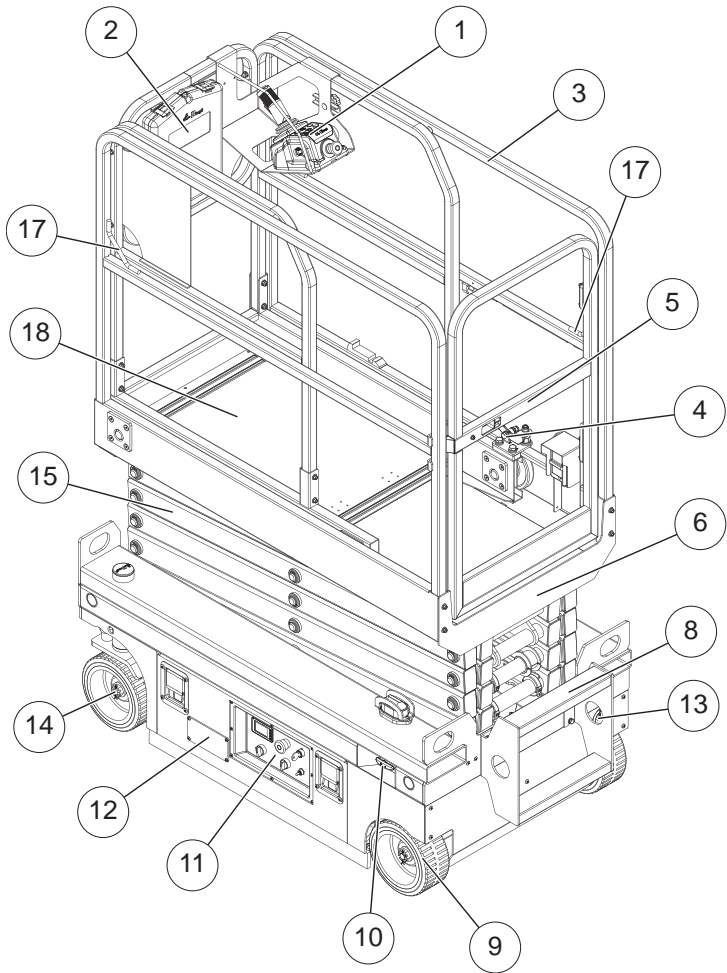

Electric Lift Cylinder, Maintenance Lock, and 3-Prong Plug shown for visual reference and clarity.

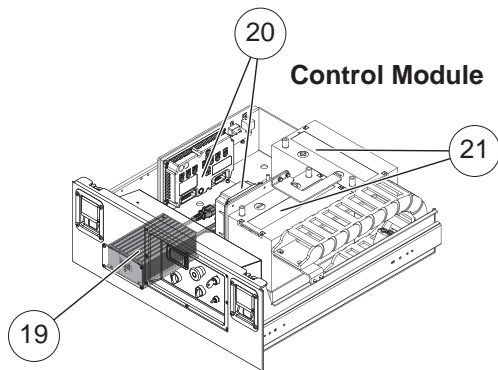

Battery Charger shown for visual reference and clarity.

- 1) Platform Controls
- 2) Manual Case
- 3) Platform Guardrails
- 4) Platform Extension Deck Release Pedal
- 5) Platform Entry Gate
- 6) Main Platform
- 7) Electric Lift Cylinder
- 8) Entry Ladder
- 9) Drive Wheels
- 10) Emergency Lowering Handle
- 11) Ground Control Panel
- 12) Battery Charger Display
- 13) Battery Charger/Power to Platform Plug (3-Prong)
- 14) Steer Wheels
- 15) Scissor Stack
- 16) Maintenance Lock
- 17) Lanyard Anchorage Point(s)
- 18) Platform Extension Deck
- 19) Battery Charger
- 20) Motor Controllers (2x)
- 21) Batteries (2x)

ILLUSTRATION No.
ART_6196

Platform Controls

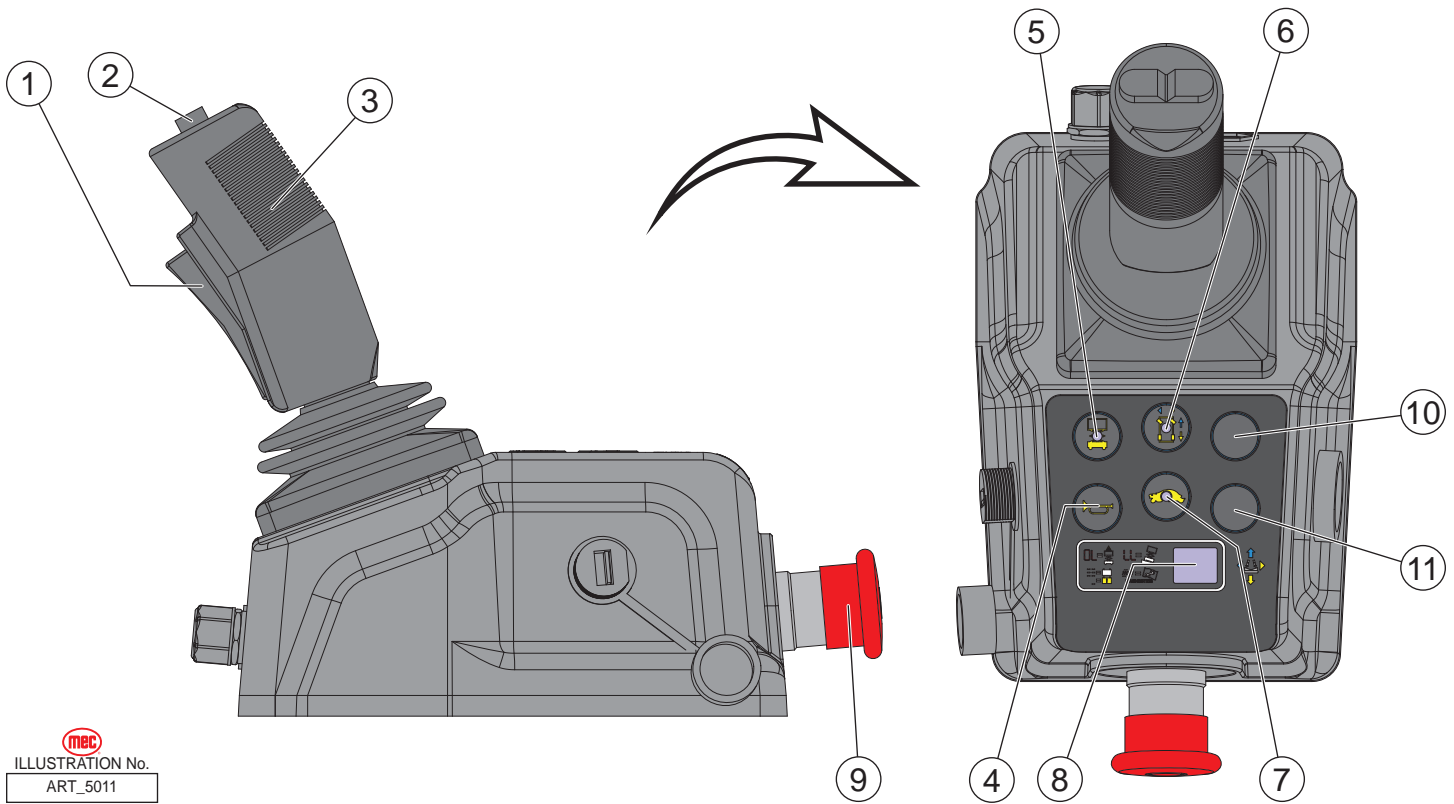

 ILLUSTRATION No.
ART_5011



WARNING

ALWAYS be aware of the machine's position and of your surroundings before activating any control function.

Control		Description
1	Function Enable Switch	Squeeze the Function Enable Switch to enable Lift & Drive & Steer functions from Control Handle.
2	Steer Switch	Using your thumb, press the thumb rocker switch in either direction to activate Steer Left or Right function.
3	Control Handle	Drive Proportionally controls Forward and Reverse travel.
		Lift Proportionally controls Lift and Lower functions.
4	Horn Button	Press to sound warning horn.
5	Lift Select	Press this button to enable the Lift function.
6	Drive Select	Press this button to enable the Drive function.
7	Drive Speed Select	Press this button to activate the low speed or high speed drive function. Light on indicates Low Speed Drive is selected. Light off indicates High Speed Drive is selected.
8	LED Display	Indicates the state of battery charge and displays diagnostic codes when necessary.
9	Emergency Stop Switch	Pull the button out to the On position (pulled out) to operate the machine. Push in the Emergency Stop switch at any time to stop all machine functions.
10	Reservation Button 1	Used for releasing the brakes. See page 37
11	Reservation Button 2	Used for releasing the brakes. See page 37

Lower Controls

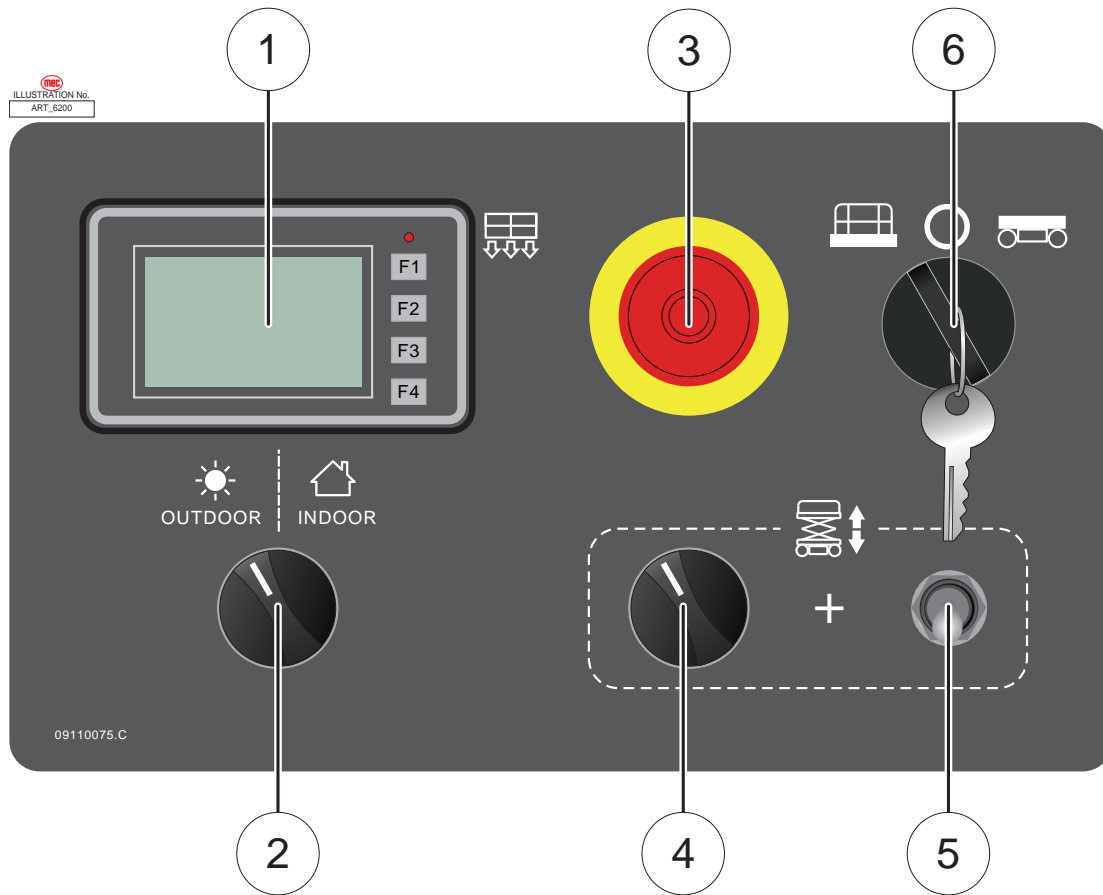

WARNING

ALWAYS be aware of the machine’s position and of your surroundings before activating any control function.

Control		Description	
1	LED Display	Indicates the state of battery charge and displays diagnostic codes when necessary.	
2	Indoor/Outdoor Switch	Indoor	Select to allow unrestricted height when indoors.
		Outdoor	Select to limit the maximum height when outdoors.
3	Emergency Stop Switch	Pull the button out to the On position (pulled out) to operate the machine. Push in the Emergency Stop switch at any time to stop all machine functions.	
4	Function Enable Button	Turn right and hold the Function Enable Button to be able to enable the Platform Lift Switch function.	
5	Platform Lift Switch	While the Function Enable Button is turned, move the switch up to lift up the platform or push the switch down to lower the platform.	
6	Key Switch	Platform	Turn the key switch to the platform position and the platform controls will be selected.
		Off	Turn the key switch to the off position (pushed in) and the machine will be off.
		Base	Turn the key switch to the base position and the ground controls will be selected.

Workplace Inspection

DO NOT operate this machine until you have read and understood this manual, have performed the Workplace Inspection, Pre-Start Inspection and Routine Maintenance, and have completed all the test operations detailed in the Operating Instructions section.

Inspect the workplace and determine whether the workplace is suitable for safe machine operation. Do this before moving the machine to the workplace.

Be sure the lift is the correct machine for the job.

Be aware of workplace conditions, and continue to watch for hazards while operating the machine.

Workplace Inspection

Before operating the machine, check the workplace for all possible hazards, including but not limited to:

- Drop-offs or holes, including those concealed by water, ice, mud, etc.
- Sloped, unstable or slippery surfaces
- Bumps, surface obstructions and debris
- Overhead obstructions and electrical conductors
- Other objects or equipment
- Hazardous locations and atmospheres
- Inadequate surface and support to withstand all load forces imposed by the machine
- Wind and weather conditions
- The presence of unauthorized personnel
- Other possible unsafe conditions

Functions Tests

DO NOT operate this machine until you have read and understood this manual, have performed the Workplace Inspection, Pre-Start Inspection and Routine Maintenance, and have completed all the test operations detailed in the Operating Instructions section.

This section provides instructions and tests for each function of machine operation. Follow all safety rules and instructions. The operator must conduct inspections and a Functions Test of the machine before each work shift to check that all machine systems are working properly.

Test the machine on a firm level surface with no debris, drop-offs, potholes or overhead obstructions. Perform each step outlined in this section.

This machine shall only be operated by trained and authorized personnel. If multiple operators use this machine, all must be trained, qualified and authorized to use it. New operators must perform a Pre-Start Inspection and Functions Test prior to operating the machine.

Operators must comply with all employer and job site rules and governmental regulations regarding the use of personal protective equipment.

DO NOT use a machine that is malfunctioning. If any function does not perform as described, tag the machine and remove for repair by a qualified service technician. After repairs are completed, a Pre-Start Inspection and Functions Test must be performed before using the machine.



Check the area above and around the machine for obstructions and electrical power lines before operating the machine. The machine must have space to allow full elevation of platform.

Prestart

Perform Prestart Inspection (see page 30).

Check the red Emergency Stop buttons at both the lower control and platform controls, pull them both out to reset.



ART_3353

Functions Test

1. Select a test area that is firm, level and free of obstruction.
2. Be sure the battery pack is connected.

At the Ground Controls

1. Pull the red Emergency Stop button out to the On position (pulled out) at both the ground and platform controls.
2. Turn the Key Switch to the lower controls.
3. Observe the diagnostic LED readout on the ECU window located at the Platform Controls.
 - **Result:** The LED should look similar to the picture right.

Art_5673



4. Observe the LED readout screen on the window.
 - **Result:** The LED will come on and display system ready.

Test Emergency Stop

1. Push in the lower red Emergency Stop button to the Off position (pushed in).
 - **Result:** No functions should operate.
2. Pull out the lower red Emergency Stop button to the On position (pulled out).

Test Up/Down Functions



Check the area above and around the machine for obstructions and electrical power lines before operating the machine.

A buzzer with different sound frequency is controlled in the computer system. The descent alarm sounds at 60 beeps per minute. The alarm that goes off when the pothole guards have not deployed sounds at 180 beeps per minute. The alarm that goes off when the machine is not level sounds at 180 beeps per minute. An automotive-style horn is also available.

1. At the lower controls, turn the Key Switch to the Off or Platform position.
2. At the lower controls, push up and hold the Platform Lift Switch.
 - **Result:** No function should operate.
3. Turn the Key Switch to the lower controls.
4. At the lower controls, turn the Function Enable Switch right and hold, then push up the Platform Lift Switch.
 - **Result:** The platform should raise.
5. Turn the Function Enable Switch right and hold then push down the Platform Lift Switch.
 - **Result:** The platform should lower to end. The descent alarm should sound while the platform is lowering.

Test the Emergency Lowering

1. Raise the platform approximately 2 feet (60 centimeters).
2. Pull the red Emergency Lowering Handle.
 - **Result:** The platform should lower. The descent alarm will not sound.

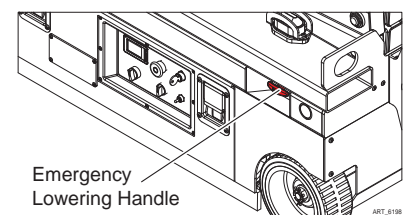

At the Platform Controls

1. Turn the Key Switch to the Platform position.

Test Emergency Stop

1. Push in the ground red Emergency Stop switch to the Off position (pushed in).
 - **Result:** No functions should operate.
2. Pull out the ground red Emergency Stop switch to the On position (pulled out).
 - **Result:** The LED indicator light should come on.

Test the Horn

1. Push the horn button.
 - **Result:** The horn should sound.

Test Function Enable and Up/Down Functions



Check the area above and around the machine for obstructions and electrical power lines before operating the machine.

1. Press the Lift select button.
2. Do not hold the Function Enable Switch on the control joystick.
3. Slowly move the control joystick forward/downward, then rearward/upward.
 - **Result:** No functions should operate.
4. Press and hold the Function Enable Switch on the control joystick.
5. Slowly pull the control joystick rearward/upward.
 - **Result:** The platform should raise. The pothole guards should deploy.
6. Release the control joystick.
 - **Result:** The platform should stop raising.
7. Press and hold the Function Enable Switch. Slowly push the control joystick forward/downward.
 - **Result:** The platform should lower. The descent alarm should sound while the platform is lowering.

Test the Steering

Note: When performing the steer and drive function tests, stand in the platform facing the steer end of the machine.

1. Press the Drive select button.
2. Press and hold the Function Enable Switch on the control joystick.
3. Press the thumb rocker switch on top of the control joystick in the direction identified by the blue left arrow on the control panel.
 - **Result:** The steer wheels should turn in the direction that the blue left arrow points on the control panel.
4. Press the thumb rocker switch in the direction identified by the yellow right arrow on the control panel.
 - **Result:** The steer wheels should turn in the direction that the yellow right arrow points on the control panel.

Test Drive and Braking

1. Press and hold the Function Enable Switch on the control joystick.
2. Slowly move the control joystick forward/downward until the machine begins to move, then return the handle to the center position.
 - **Result:** The machine should move forward, in the direction of the steering wheels, then come to an abrupt stop.
3. Press and hold the Function Enable Switch on the control joystick.

4. Slowly move the control joystick rearward/upward until the machine begins to move, then return the handle to the center position.
 - **Result:** The machine should move rearward, in the direction of the platform entry, then come to an abrupt stop.

Note: The brakes must be able to hold the machine on any slope it is able to climb.

Test Limited Drive Speed

1. Press the Lift select button.
2. Press the Function Enable Switch. Raise the platform approximately 4.3 feet (1.3 meters) from the ground.
 - **Result:** The pothole guards should deploy.
3. Press the Drive select switch.
4. Press and hold the Function Enable Switch on the control joystick.
5. Slowly move the control joystick to the full drive position.
 - **Result:** The maximum achievable drive speed with the platform raised should not exceed 0.55 feet per second (16.7 centimeters per second).
 - If the drive speed with the platform raised exceeds 0.55 feet per second (16.7 centimeters per second), immediately tag and remove the machine from service.

Test the Tilt Sensor Operation

Note: Perform this test from the ground with the platform controller. Do not stand in the platform.

1. Fully lower the platform.
2. Place a 1.2×7.9inch (3×20 centimeter) or similar piece of wood under both wheels on one side and drive the machine up onto them.
3. Raise the platform approximately 4.3 feet (1.3 meters) from the ground.
 - **Result:** The platform should stop and the tilt alarm will sound at 180 beeps per minute. The platform controls LED readout should display LL.
4. Press the Drive select button.
5. Press and hold the function enable switch on the control joystick.
6. Move the control joystick in the direction indicated by the blue arrow, then move the control joystick in the direction indicated by the yellow arrow.
 - **Result:** The drive function should not work in either direction.
7. Lower the platform and drive the machine off the block.

Test the Pothole Guards

Note: The pothole guards should automatically deploy when the platform is raised. The pothole guards activate another limit switch which allows the machine to continue to function. If the pothole guards do not deploy, an alarm sounds and the machine will not drive and lift.

1. Raise the platform.
 - **Result:** When the platform is raised approximately 4.3 feet (1.3 meters) from the ground, the pothole guards should deploy.
2. Press on the pothole guards on one side, and then the other.
 - **Result:** The pothole guards should not move.

3. Lower the platform.
 - **Result:** The pothole guards should return to the stowed position.
4. Place a 1.2x7.9inch (3x20 centimeter) or similar piece of wood under a pothole guard. Raise the platform.
 - **Result:** When the platform is raised approximately 4.3 feet (1.3 meters) from the ground, the pothole alarm will sound at 180 beeps per minute, and the platform controls LED screen readout should display 18.
5. Press the drive function select button.
6. Press and hold the function enable switch on the control joystick.
7. Move the control joystick in the direction indicated by the blue arrow, and then move the control joystick in the direction indicated by the yellow arrow.
 - **Result:** The drive function should not work in either direction.
8. Press and hold the function enable switch on the control joystick.
9. Depress the thumb rocker switch on top of the control joystick in the direction identified by the blue and yellow arrow on the control panel.
 - **Result:** The steer function should not work in either direction.
10. Lower the platform and remove the 1.2x7.9inch (3x20 centimeter) wood block.

Test the Indoor/Outdoor function

Note: Perform this test from the ground with the platform controller. Do not stand in the platform.

1. Turn the Key Switch to the lower controls.
2. Turn the Indoor/Outdoor Switch to Outdoors.
3. Turn and hold the Function Enable Button then push up the Platform Lift Switch. Raise the platform to the highest position and measure the platform height.
 - **Result:** The platform height should be around 15.1 feet (4.6 meters).
4. Turn the Indoor/Outdoor Switch to Indoors.
5. Turn and hold the Function Enable Button then push up the Platform Lift Switch. Raise the platform to the highest position and measure the platform height.
 - **Result:** The platform height should be around 18.4 feet (5.6 meters).
6. Turn the Indoor/Outdoor Switch to Outdoors.
 - **Result:** The alarm should sound.
7. Turn the Indoor/Outdoor Switch to Indoors and fully lower the platform.
8. Turn the Key Switch to the Platform position.
9. Turn the Indoor/Outdoor Switch to Outdoors.
10. Press the lift select button.
11. Press and hold the Function Enable Switch on the control joystick.
12. Slowly pull the control joystick rearward/upward. Raise the platform to the highest position and measure the platform height.
 - **Result:** The platform height should be around 15.1 feet (4.6 meters).
13. Turn the Indoor/Outdoor Switch to Indoors.
14. Press and hold the Function Enable Switch on the control joystick.
15. Slowly pull the control joystick rearward/upward. Raise the platform to the highest position and measure the platform height.
 - **Result:** The platform height should be around 18.4 ft (5.6 meters).
16. Turn the Indoor/Outdoor Switch to Outdoors.
 - **Result:** The alarm should sound.
17. Turn the Indoor/Outdoor Switch to Indoors. Fully lower the platform.

Operating Instructions



Check the area above and around the machine for obstructions and electrical power lines before operating the machine.

Emergency Stop

Push in the red Emergency Stop button to the Off position (pushed in) at the lower controls or the platform controls to stop all machine functions.

If any function operates when either red Emergency Stop button is pushed in, repair the Emergency Stop function before using the machine.



Emergency Lowering



If the control system fails while the platform is elevated, use the emergency lowering procedure to safely lower the platform.

Do not climb down the scissor assembly or exit the platform.

The red Emergency Lowering Handle is used to lower the platform in case of power failure. Pull the Emergency Lowering handle to lower the platform.

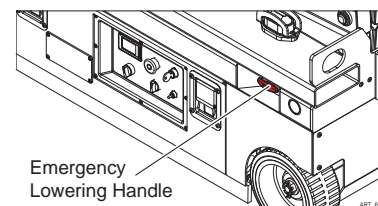

Indoor/Outdoor Switch

Select working environment before using machine.

- Turn the switch left to select Outdoor mode to restrict platform height when working outdoors.
- Turn the switch right to select Indoor mode to allow unrestricted platform height when working indoors.



Art_5587

Platform Overload

Indicates too much weight on the platform. Remove excess weight from the platform to restore function and continue.

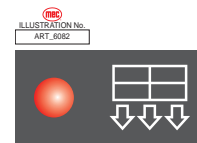

Operation from Ground

Drive and steer functions are not available from the lower controls!

1. Turn the Key Switch to the lower controls.
2. Pull the red Emergency Stop button out to the On position (pulled out) at both the ground and platform controls.
3. Be sure the battery pack is connected before operating the machine.



ART_4989



Check the area above and around the machine for obstructions and electrical power lines before operating the machine.

To Position the Platform

The Function Enable Switch must be turned and held to activate the Lift/Lower function.

- Push the switch up to lift the platform.
- Push the switch down to lower the platform.

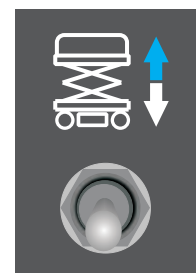

ART_4988

Operation from Platform

1. Turn the Key Switch to the platform position.
2. Pull the red Emergency Stop button out to the On position (pulled out) at both the ground and platform controls.
3. Be sure the battery pack is connected before operating the machine.

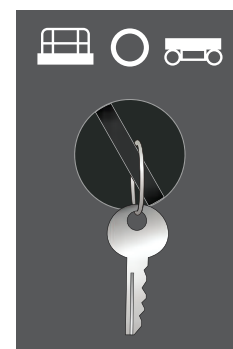

ART_4987



Check the area above and around the machine for obstructions and electrical power lines before operating the machine.

To Position Platform

1. Press the lift function select button.
2. Press and hold the Function Enable Switch on the control joystick.
3. Pull the control joystick upward to raise the platform.
4. Push the control joystick downward to lower the platform.



Control Handle

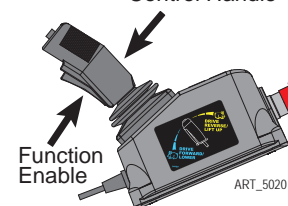

ART_5020

To Steer

1. Press the drive function select button.
2. Press and hold the Function Enable Switch on the control joystick.
3. Turn the steer wheels with the thumb rocker switch located on the top of the control joystick.



Steer Switch

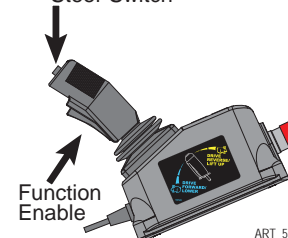

ART_5021

To Drive

1. Press the drive function select button.
2. Press and hold the Function Enable Switch on the control joystick.
 - **Increase speed:** Slowly move the control joystick off center.
 - Push the control joystick forward to move forward. Pull the control joystick rearward to move rearward.
 - **Decrease speed:** Slowly move the control joystick toward center.
 - **Stop:** Return the control joystick to center or release the Function Enable Switch.

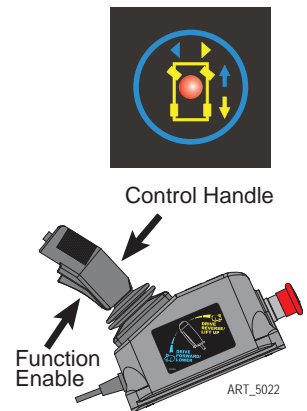

Use the color-coded direction arrows on the platform controls to identify the direction the machine will travel.

Machine travel speed is restricted when the platform is raised.

Battery condition will affect machine performance. Machine drive speed and function speed will drop when the battery level indicator is flashing.

To Reduce Drive Speed

The drive controls can operate in two different drive speed modes.

- When the drive speed button light is on, slow drive speed mode is active.
- When the button light is off, fast drive speed mode is active.

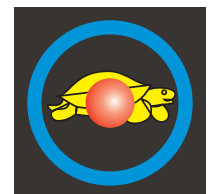

Press the drive speed button to select the desired drive speed.

Driving on a Slope

Determine the slope and side slope ratings for the machine and determine the slope grade.

- Maximum forward/rearward slope rating, stowed position 25%.
- Maximum side slope rating, stowed position 5°.

Note: Slope rating is subject to ground conditions and adequate traction.

Press the drive speed button to select the desired drive speed.

To determine the slope grade

Measure the slope with a digital inclinometer OR use the following procedure. You will need:

- Carpenter's level
- Straight piece of wood, at least 3.3 feet (1 meter) long
- Tape measure

Lay the piece of wood on the slope.

At the downhill end, lay the level on the top edge of the piece of wood and lift the end until the piece of wood is level.

While holding the piece of wood level, measure the distance from the bottom of the piece of wood to the ground.

Divide the tape measure distance (rise) by the length of the piece of wood (run) and multiply by 100.

Example:

- Run = 12 ft / 3.6 m
- Rise = 12 in / 0.3 m
- $12 \text{ in} \div 12 \text{ ft} = 0.083 \times 100 = 8.3\%$
- $0.3 \text{ m} \div 3.6 \text{ m} = 0.083 \times 100 = 8.3\%$

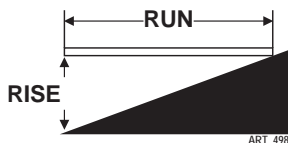

If the slope exceeds the maximum slope or side slope rating, the machine must be winched or transported up or down the slope. See Transport and Lifting section.

Operation from Ground with Controller



Use extreme caution when operating the machine with the controller from the ground.

Maintain safe distances between operator, machine and fixed objects.

Be aware of the direction the machine will travel when using the controller.

Battery Level Indicator

Use the LED diagnostic readout to determine the battery level.

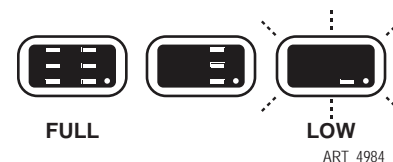

Maintenance Lock

1. Raise the platform approximately 1.3 feet (0.4 meters) from the ground.
2. Rotate the Maintenance Lock away from the machine and let it hang down.
3. Lower the platform until the Maintenance Lock rests securely on the link. Keep clear of the Maintenance Lock when lowering the platform.

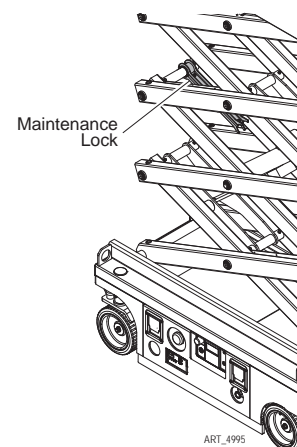

Don't engage the Maintenance Lock unless the platform is empty of tools and material.

To Extend and Retract the Deck Extension

1. Press the platform lock pin foot pedal on the extension deck.
2. Push the platform extension guardrail to extend the platform to the desired position.

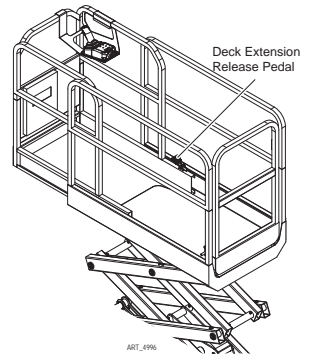

IF THE ROLL-OUT DECK IS EXTENDED CHECK FOR CLEARANCE UNDER DECK AREA BEFORE LOWERING PLATFORM.

Error Indicator Readout

The Error Indicator Readout is located at the Upper Controls station. Consult the Service & Parts Manual for Alarm Code descriptions. Manuals are available free online at www.MECawp.com.

If a load in excess of the rated load is detected the Lift/Lower function will be restricted. The excess load must be removed before movement can occur.

The platform overload is measured when the machine is stationary and not in motion.

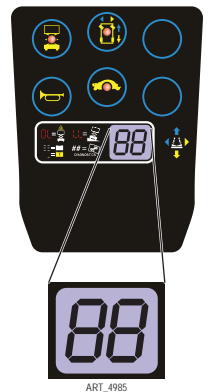

Shutdown Procedure

When finished with the machine, place the platform in the stowed position.

Park the machine on a level surface.

Turn the Key Switch to the Off position and remove the key to prevent unauthorized use. Carefully exit the platform using a constant three (3) point dismount/grip.

Always put the main power switch in Off position (pushed in) when leaving the machine at the end of the work day.

Charge the batteries.

Battery Charging

The charger surface can get hot while operating. Contact with the skin or surrounding materials should be avoided.

**WARNING**

To reduce the risk of an electric shock, connect only to a properly grounded single-phase (3 wire) outlet.

Do not use an external charger or booster battery.

Charge the battery in a well-ventilated area.

**CAUTION**

Use proper AC input voltage for charging as indicated on the machine.

Use only MEC authorized batteries and chargers.

The charger will indicate the status of the charge cycle.

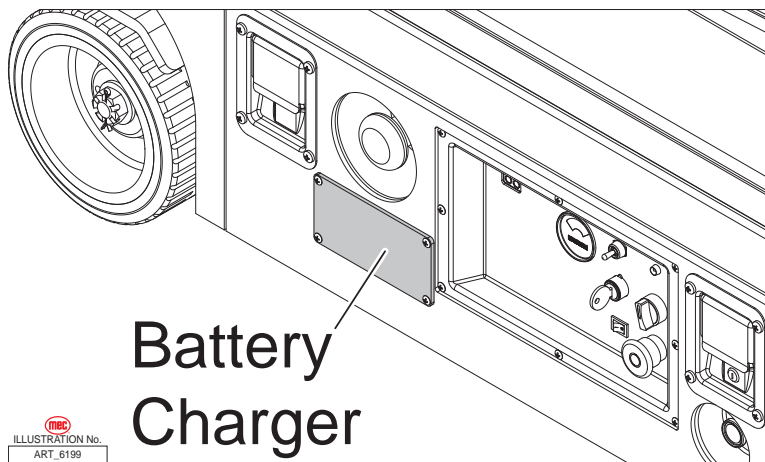



ILLUSTRATION No.
ART_5199

Maintenance

DO NOT operate this machine until you have read and understood this manual, have performed the **Workplace Inspection, Pre-Start Inspection and Routine Maintenance**, and have completed all the test operations detailed in the **Operating Instructions** section.

The operator must conduct a Pre-Start Inspection of the machine and test all functions before each work shift to check for damage, malfunction and unauthorized modification. The inspection is designed to discover if anything is apparently wrong with a machine before the operator performs the function tests.

Tag and remove a damaged, malfunctioning or modified machine from service. **DO NOT** use a damaged, malfunctioning or modified machine.

Use the Pre-Start Inspection to determine what Routine Maintenance is required. The operator may perform only the routine maintenance items specified in this manual.

IMPORTANT: Scheduled maintenance inspection checklists are included in this manual for use only by qualified service technicians. Only qualified service technicians may perform repairs to the machine. After repairs are completed, the operator must perform a Pre-Start Inspection before proceeding to the Functions Test.

NEVER perform work or inspection on the machine with the platform elevated without first blocking the scissor assembly with the **Maintenance Lock** (see page 25).

Perform scheduled maintenance at recommended intervals. Failure to perform scheduled maintenance at recommended intervals may result in a defective or malfunctioning machine and may result in injury or death of the operator. Keep maintenance records current and accurate.



Immediately report any damage, defect, unauthorized modification or malfunction to your supervisor. Any defect must be repaired prior to continued use. DO NOT use a damaged, modified or malfunctioning machine.

Use only recommended lubricants. Improper lubricants or incompatible lubricants may cause as much damage as no lubrication.



Watch for makeshift “fixes” which can jeopardize safety as well as lead to more costly repair.

Inspection and maintenance should be performed by qualified personnel familiar with the equipment.

Routine Maintenance



NEVER perform work or inspection on the machine with the platform elevated without first blocking the scissor assembly with the Maintenance Lock.

See page 25 for instructions.

IMPORTANT: The operator may perform only maintenance items on the Pre-Start Inspection Checklist. Frequent and Annual maintenance must be performed by qualified service technicians.

Pre-Start Inspection

Perform routine maintenance as identified in the Pre-Start Inspection Checklist on page 30.

Frequent and Annual Maintenance

Frequent Inspection Checklists and Annual Inspection Reports must be completed by qualified service technicians trained and authorized to perform maintenance on this machine, and must be done in accordance with the procedures outlined in the service manual. Scheduled maintenance inspection checklists are included in this manual for use by qualified service technicians.

Machines that have been out of service for more than three months must have the Frequent Inspection Checklists completed before returning to service.

Pre-Start Inspection Checklist

The operator must conduct a Pre-Start Inspection of the machine before each work shift.

DO NOT use a damaged or malfunctioning machine.

	Be sure that the operator's manual are complete, legible and in the storage container located in the platform.
	Be sure that all decals are legible and in place. See Decals section.
	Check for battery fluid leaks.

Check the following components or areas for damage, improperly installed or missing parts and unauthorized modifications:

	Electrical components, wiring and electrical cables
	Battery connections
	Battery pack and connections
	Drive motors
	Slide blocks/wear pads
	Tires and wheels
	Ground strap
	Limit switches, alarm and beacon
	Nuts, bolts and other fasteners
	Platform entry gate
	Beacons and alarms
	Maintenance Lock
	Platform extension
	Scissor pins and retaining fasteners
	Platform control joystick
	Brake release components
	Pothole guards

Check entire machine for:

	Cracks in welds or structural components
	Dents or damage to machine
	Be sure that all structural and other critical components are present and all associated fasteners and pins are in place and properly tightened
	Be sure that guard rails are properly installed and secured, and that all pins and bolts are properly fastened.
	Be sure that the chassis trays are closed and latched and the batteries are properly connected.



NEVER perform work or inspection on the machine with the platform elevated without first blocking the scissor assembly with the Maintenance Lock. See page 25 for instructions.

Frequent Inspection Checklist



This checklist must be used at 3-month intervals or every 150 hours of machine use, whichever occurs first. Failure to do so could result in death or serious injury.

Frequent Maintenance Inspections should be conducted by qualified service technicians only. Photocopy this page for reuse. Keep inspections records up to date. Record and report all discrepancies to your supervisor. See the Service & Parts Manual for specific instructions.

Model Number _____ Serial Number _____ Hour Meter Reading _____

	Perform all checks listed on Pre-Start Inspection.
	Grease the Steering Yokes
	Batteries
	Electrical wiring
	Tires and wheels
	Emergency stop
	Key switch
	Horn
	Drive Brakes
	Drive Speed, Stowed Platform
	Drive Speed, Raised Platform
	Drive Speed, Slow
	Latch Components
	Test Down & Pothole limit switches
	Test Up limit switches

Date _____ Inspected By _____

Maintenance Inspection Report

ALL-ELECTRIC, SE & MICRO Series Scissors

Fleet Equipment Number _____ Date _____
 Inspector Name _____ Inspector Co. _____
 Model Number _____ Address _____
 Serial Number _____
 Hour Meter _____ Signature _____
 Machine Owner & address _____

Maintain all service records in accordance with ANSI A92.24-2019

* If an inspection receives an "N", remove from service. Once repaired, place an "R" in the box.
 * Refer to the proper service manual for specific information, settings and torque specifications.

Key Y = Yes, Acceptable N = No, Remove from Service R = Repaired 0 = Not Applicable

QUARTERLY - Inspect only those marked "Q" **ANNUAL** - Inspect all items

	Q/A	Y/N/O	R
DECALS:			
Legible - undamaged/readable	Q		
Capacity decal correct for model	Q		
RAILS:			
Not damaged, all in place	Q		
All rail fasteners secure	Q		
Entry gate secure, closes properly	Q		
Manual box in good condition	Q		
Operators Manual in manual box	Q		
PLATFORM EXTENSION:			
Rolls in and out freely	Q		
Lock holds deck in place	Q		
Release pedal moves freely (lube)	Q		
ELEVATING ASSEMBLY:			
Scissor Slide Blocks, lubed	Q		
Maintenance Stand, good Cond	Q		
Beam structures: Straight, no cracks	A		
Welds: secure, no cracks	A		
Retaining Rings	A		
Cylinder Pins, secure	A		
ELECTRICAL:			
GFCI operates correctly	Q		
Wire harnesses good cond, secure	A		
Comm cable no damage, secure	A		
BASE:			
Fasteners tight	Q		
Cover panels secure	Q		
Welds	A		

	Q/A	Y/N/O	R
WHEELS:			
Tire damage	Q		
Lug nuts (Wheel mounting) torqued correctly	Q		
King Pins lubed	A		
COMPONENT AREA:			
Batteries filled (Flooded-type Only)	Q		
Emergency Stop, Cuts all power	Q		
Battery Switch, Stops all power when pushed	Q		
Plastic Cover on door end, secure	Q		
Lift Actuator(s) mounting tight	Q		
Steer Actuator, Mounting tight	A		
Drive Motors, fasteners tight, No leaks from hubs	Q		
OPERATIONAL INSPECTION:			
All functions, operate smooth and quiet	Q		
All functions, speeds correct	Q		
Upper control box, operates correctly	Q		
Emergency Down, operates correctly	Q		
Limit switches slows drive when elevated	Q		
Pothole switch test	Q		
Steering pressure relief, set correctly	Q		
Test Platform Overload Sensing operation	Q		



Decals

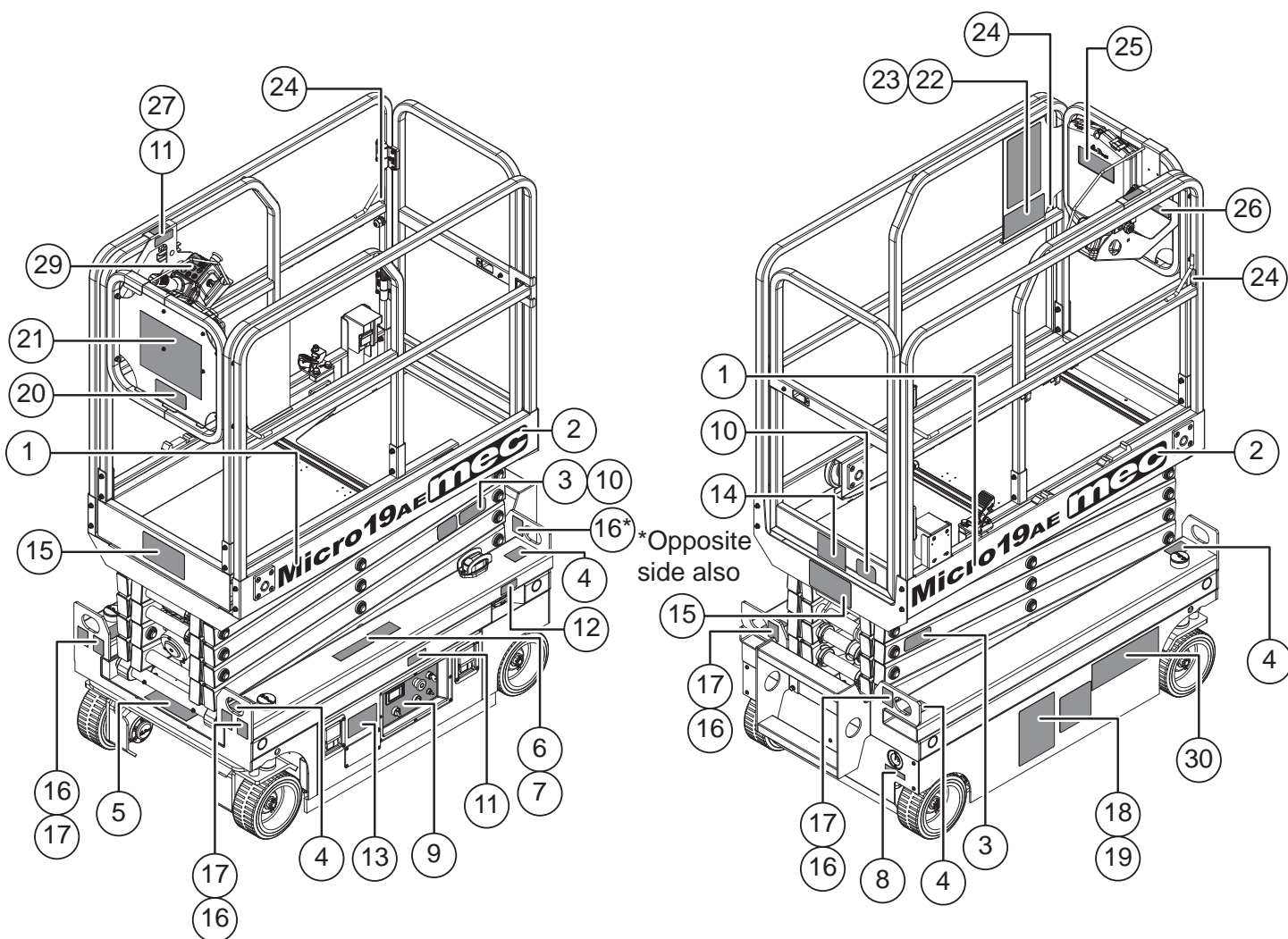



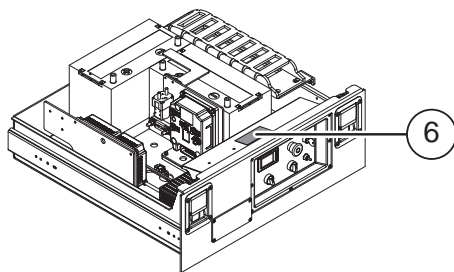



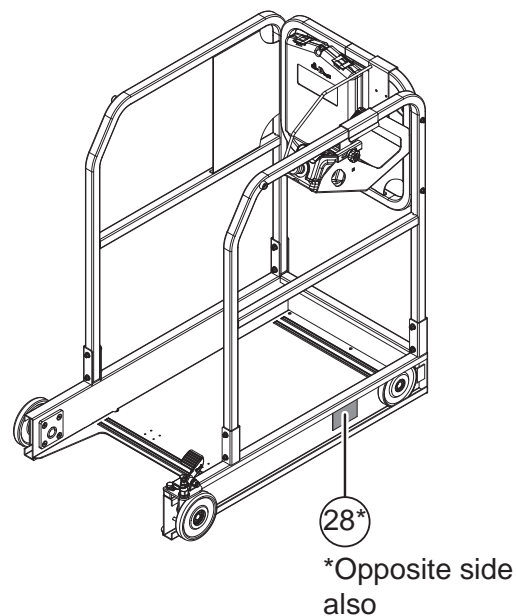

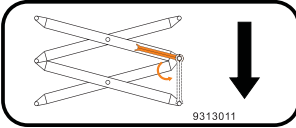



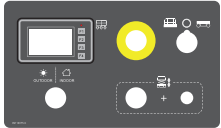

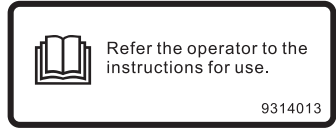

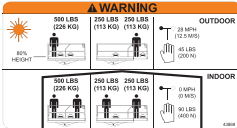







Control Modue

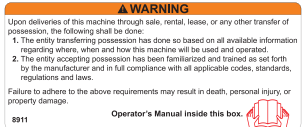

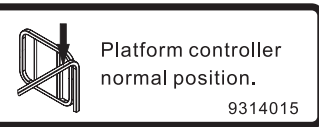
Platform Deck Extended



<p>1</p> <p>Micro19AE</p> <p>96688 Qty. - 2</p>	<p>2</p> <p>mec</p> <p>94114 Qty. - 2</p>	<p>3</p>  <p>41638 Qty. - 2</p>	<p>4</p>  <p>94362 Qty. - 4</p>
<p>5</p>  <p>95215 Qty. - 1</p>	<p>6</p>  <p>90732 Qty. - 2</p>	<p>7</p>  <p>42534 Qty. - 1</p>	<p>8</p> <p>BATTERY CHARGER AND POWER TO PLATFORM</p> <p>94659 Qty. - 1</p>
<p>9</p>  <p>45656 Qty. - 1</p>	<p>10</p>  <p>96689 Qty. - 1</p>	<p>11</p>  <p>41639 Qty. - 2</p>	<p>12</p> <p>EMERGENCY LOWER</p> <p>Pull knob to lower platform</p> <p>9311017</p> <p>41636 Qty. - 1</p>
<p>13</p>  <p>42493 Qty. - 1</p>	<p>14</p>  <p>95301 Qty. - 1</p>	<p>15</p>  <p>43869 Qty. - 2</p>	<p>16</p>  <p>41635 Qty. - 4</p>
<p>17</p>  <p>41634 Qty. - 4</p>	<p>18</p>  <p>41649 Qty. - 1</p>	<p>19</p>  <p>41641 Qty. - 1</p>	<p>20</p>  <p>94423 Qty. - 1</p>
<p>21</p>  <p>90719 Qty. - 1</p>	<p>22</p>  <p>43885 Qty. - 1</p>	<p>23</p>  <p>41647 Qty. - 1</p>	<p>24</p>  <p>41648 Qty. - 3</p>
<p>25</p>  <p>8911 Qty. - 1</p>	<p>26</p>  <p>94120 Qty. - 1</p>	<p>27</p>  <p>41640 Qty. - 1</p>	<p>28</p>  <p>91850 Qty. - 2</p>
<p>29</p>  <p>44797 Qty. - 1</p>	<p>30</p>  <p>96686 Qty. - 1</p>		

Serial Plate

Serial Plate Location

The serial plate is attached to the machine at the time of manufacture. Important information about the machine is recorded on the serial plate.

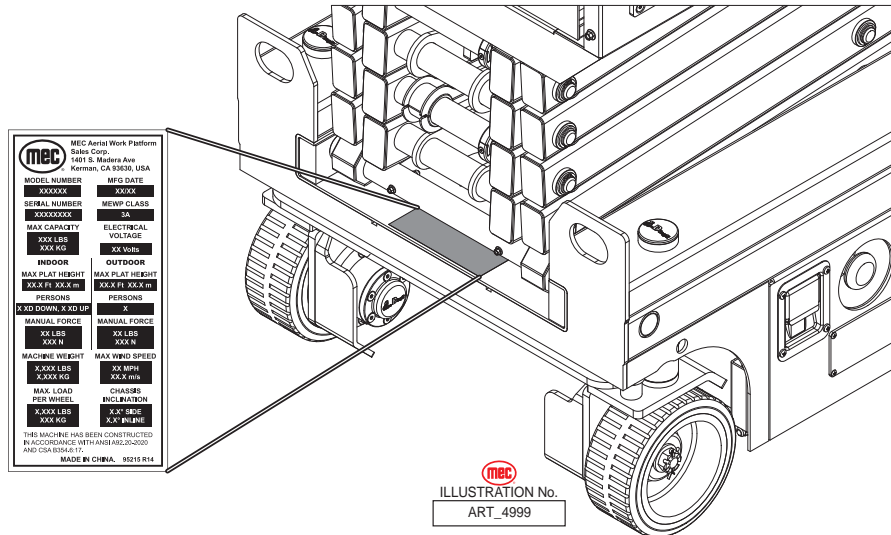

Serial Plate Description

MODEL NUMBER: Identifies the machine.

MFG DATE: Month / Year of manufacture.

SERIAL NUMBER: Identifies a machine with reference to its original owner. Refer to the number when requesting information or ordering parts.

MEWP CLASS: MEWP=Mobile Elevating Work Platform

MAX. CAPACITY: The maximum safe load (material, persons + equipment) which can be correctly placed on the platform at any elevation.

ELECTRICAL VOLTAGE: The voltage at which this machine operates.

MAX. PLATFORM HEIGHT (INDOOR): The indoors maximum attainable height measured from level ground surface to platform floor.

PERSONS (INDOOR): The maximum number of occupants indoors.

MANUAL FORCE (INDOOR): Amount of manual force need to move machine indoors.

MAX. PLATFORM HEIGHT (OUTDOOR): The outdoors maximum attainable height measured from level ground surface to platform floor.

PERSONS (OUTDOOR): The maximum number of occupants outdoors.

MANUAL FORCE (OUTDOOR): Amount of manual force need to move machine outdoors.

MACHINE WEIGHT: The weight of the machine with no options.

MAX WIND SPEED: The maximum wind speed for safe working conditions.

MAX. LOAD PER WHEEL: The maximum safe weight applied to each wheel. Calculated with all available options installed. $F_w = 30\% (W_m + W_c + W_{opt})$

CHASSIS INCLINATION: The maximum amount of tilt for safe working conditions.

Troubleshooting

Should you experience erratic operation or notice any malfunction while operating this machine, discontinue use immediately.



Call for assistance and report the incident to your supervisor, and do not use the machine until it has been checked by a trained, qualified mechanic.

Machine functions will not operate

- Master disconnect turned on?
- Batteries properly connected?
- Batteries fully charged?
- Key Switch in proper position?
- Both Emergency Stop Switches reset?
- Function Enable Switch not activated?
- Obvious fluid leak or damaged component?
- Wires disconnected, broken, or loose?
- Diagnostic panel on?
- Platform Control Box Fault Code present?
 - Contact MEC Technical Support or refer to service manual. Manuals are available free online at www.MECawp.com.

Transport and Lifting Instructions

Safety Information

This section is provided for reference and does not supersede any government or company policy regarding the loading, transport or lifting of MEC machinery.

Truck drivers are responsible for loading and securing machines, and should be properly trained and authorized to operate MEC machinery. Drivers are also responsible for selecting the correct and appropriate trailer according to government regulations and company policy. Drivers must ensure that the vehicle and chains are strong enough to hold the weight of the machine (see the serial number plate for machine weight).



While loading and unloading, the transport vehicle must be parked on a level surface and secured to prevent rolling.

Loading: Free-wheel configuration for Winching or Towing

RUNAWAY HAZARD!



After releasing the brakes there is nothing to stop machine travel. Machine will roll freely on slopes.

ALWAYS chock the wheels before manually releasing the brakes.

It is not recommended, but the machine can be winched or towed short distances at speeds not to exceed 2.5mph (4km/h).

Before towing or winching the machine, it is necessary to release the brakes. Reset the brakes after towing or winching.

Brake Release

1. Chock the wheels to prevent the machine from rolling.
2. When the machine is powered on, press and hold both "Reservation Button 1" and "Reservation Button 2" on the platform controller at the same time, the LED readout screen display "--" indicating that the system enter the configuration mode.
3. Press and hold the Drive select button for 3 seconds. The LED readout screen will display "br", The brakes will be released after an alarm sounds.
4. To reset the brakes, turn the Key Switch to the Off position or push in an Emergency Stop button.

Always attach the machine to a winch when loading or unloading from a truck or trailer by driving.



Read and understand all safety, control, and operating information found on the machine and in this manual before operating the machine.

Before loading or unloading the machine, check that:

- The deck extension, controls and component trays are secure.
- The platform is fully lowered.
- All loose items have been removed.

Before driving or winching the machine:

- Attach the machine to a winch.
- Remove all machine tie downs. Remove wheel chocks.

Driving

- Turn the Key Switch to the Platform position. Check that the Emergency Stop Switch is reset by pulling it out to the On position (pulled out).
- Enter the platform and reset the Platform Emergency Stop Switch.
- Test the platform control functions.
- Make to be in slow drive speed mode. Carefully drive the machine off the transport vehicle with the winch attached.

Note: The brakes are automatically released for driving and will automatically apply when the machine stops.

Winching

- Disengage brakes (see Brake Release on page 37).
- Carefully operate the winch to lower the machine down the ramp.
- Chock the wheels and engage the brakes.



Lifting the machine from the side may result in component damage.

Lifting the machine with a Forklift

- Position the forklift forks in line with the forklift pockets.
- Drive forward to the full extent of the forks.
- Raise the machine 6 inches (15 centimeters) and then tilt the forks back slightly to keep the machine secure.
- Be sure the machine is level when lowering the forks.

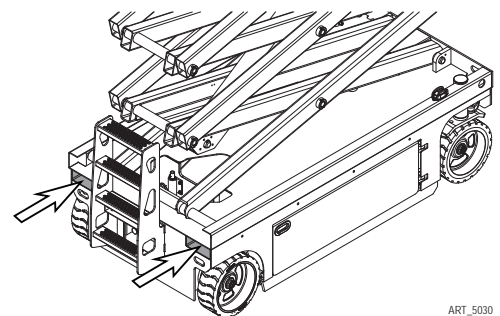

ART_5030



Ensure that angle of each hold-down chain or strap does not exceed 30° relative to the trailer deck.

Securing to truck or trailer for Transport

- Turn the Key Switch to the Off position and remove the key before transport.
- Inspect the entire machine for loose or unsecured items.
- Chock the wheels
- Use the tie-down points on the chassis for anchoring down to the transport surface.
- Use chains or straps of ample load capacity.
- Use a minimum of four (4) chains or straps.
- Adjust the rigging to prevent damage to the chains and the machine.

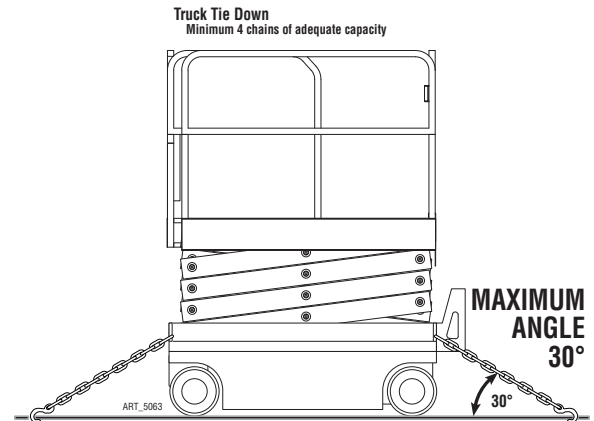

Lifting Instructions

Only qualified riggers should rig and lift the machine.



Ensure that the crane, loading surfaces, spreader bars, cables, chains and straps are of sufficient capacity to withstand the machine weight. See the serial plate for the machine weight.

- Fully lower the platform. Be sure the deck extension is retracted and the controls and component trays are closed and secure. Remove all loose items from the machine.
- Determine the center of gravity of the machine.
- Attach rigging to the designated lift points only.
- Adjust the rigging to prevent damage to the machine and to keep the machine level.

Machine Storage

- The machine should be stored indoors with the ground being flat and hard. If the machine is to be stored outdoors make sure that the machine is covered to protect it from environmental damage.
- Before storing the machine, make sure that it is clean and functional along with having the platform empty of any tools and equipment. Make sure that the machine is functional before storing it.
- When storing the machine, park the machine in a suitable location so that the machine can be driven or moved without issue.



When the machine has been stored for a long time, it can not be used until it has been inspected and maintained according to the daily check procedure and function test.

Rust Protection

1. Before the machine is stored, inspect the paint and repaint any chipped or imperfect areas on the machine to protect the machine from rust.
2. For moving components, grease must be applied to prevent rust or damage, such as bearings, joints and sliding rails.

Battery Storage

1. When storing the machine for a long time (one month to six months) be sure to turn off the main power switch, key switch, the emergency stop switch, and fully charged. In order to ensure that these batteries stay ready for operation, the following charging procedures must be applied:
 - Check the voltage of each battery on the machine once a month to ensure that the voltage of battery is not lower than 25.2V, otherwise please charge the machine immediately.
2. When storing the machine for a long time (half a year or more), it should be fully charged. The batteries should be removed from the machine. Keep the batteries clean and ensure nothing is placed on the top of batteries. The following battery disconnecting procedures must be applied:
 - Disconnect the wire from the negative terminal first the disconnect the wires from the positive terminal.
 - The batteries should be connected as follow: first connect the positive power wires with the positive terminal then connect the negative cable line to the negative terminal finally.
 - In order to ensure that these batteries stay ready for operation, the batteries should be charged one time in every quarter.

Brake Inspection

1. When storing the machine for a long time, 1 month to half a year, the brake release procedure should be performed once a month to prevent the brake pads from sticking.
2. If the brake pads are stuck, the brake assembly need to be replaced.

Notes



Limited Owner Warranty

MEC Aerial Platform Sales Corp. warrants its equipment to the original purchaser against defects in material and/or workmanship under normal use and service for one (1) year from date of registered sale or date the unit left the factory if not registered. MEC Aerial Platform Sales Corp. further warrants the structural weldments of the main frame and scissor arms to be free from defects in material or workmanship for five (5) years from date of registered sale or date unit left the factory if not registered. Excluded from such warranty is the battery(s) which carries a ninety (90) day warranty from described purchase date. Warranty claims within such warranty period shall be limited to repair or replacement, MEC Aerial Platform Sales Corp's option, of the defective part in question and labor to perform the necessary repair or replacement based on MEC Aerial Platform Sales Corp's then current flat rate, provided the defective part in question is shipped prepaid to MEC Aerial Platform Sales Corp. and is found upon inspection by MEC Aerial Platform Sales Corp. to be defective in material and/or workmanship. MEC Aerial Platform Sales Corp. shall not be liable for any consequential, incidental or contingent damages whatsoever. Use of other than factory authorized parts; misuse, improper maintenance, or modification of the equipment voids this warranty. The foregoing warranty is exclusive and in lieu of all other warranties, express or implied. All such other warranties, including implied warranties of merchantability and of fitness for a particular purpose, are hereby excluded. No Dealer, Sales Representative, or other person purporting to act on behalf of MEC Aerial Platform Sales Corp. is authorized to alter the terms of this warranty, or in any manner assume on behalf of MEC Aerial Platform Sales Corp. any liability or obligation which exceeds MEC Aerial Platform Sales Corp's obligations under this warranty.



MEC Aerial Work Platforms

1401 S. Madera Avenue, Kerman, CA 93630 USA

Toll Free: 1-877-632-5438

Phone: 1-559-842-1500

Fax: 1-559-842-1520

info@MECawp.com

www.MECawp.com