

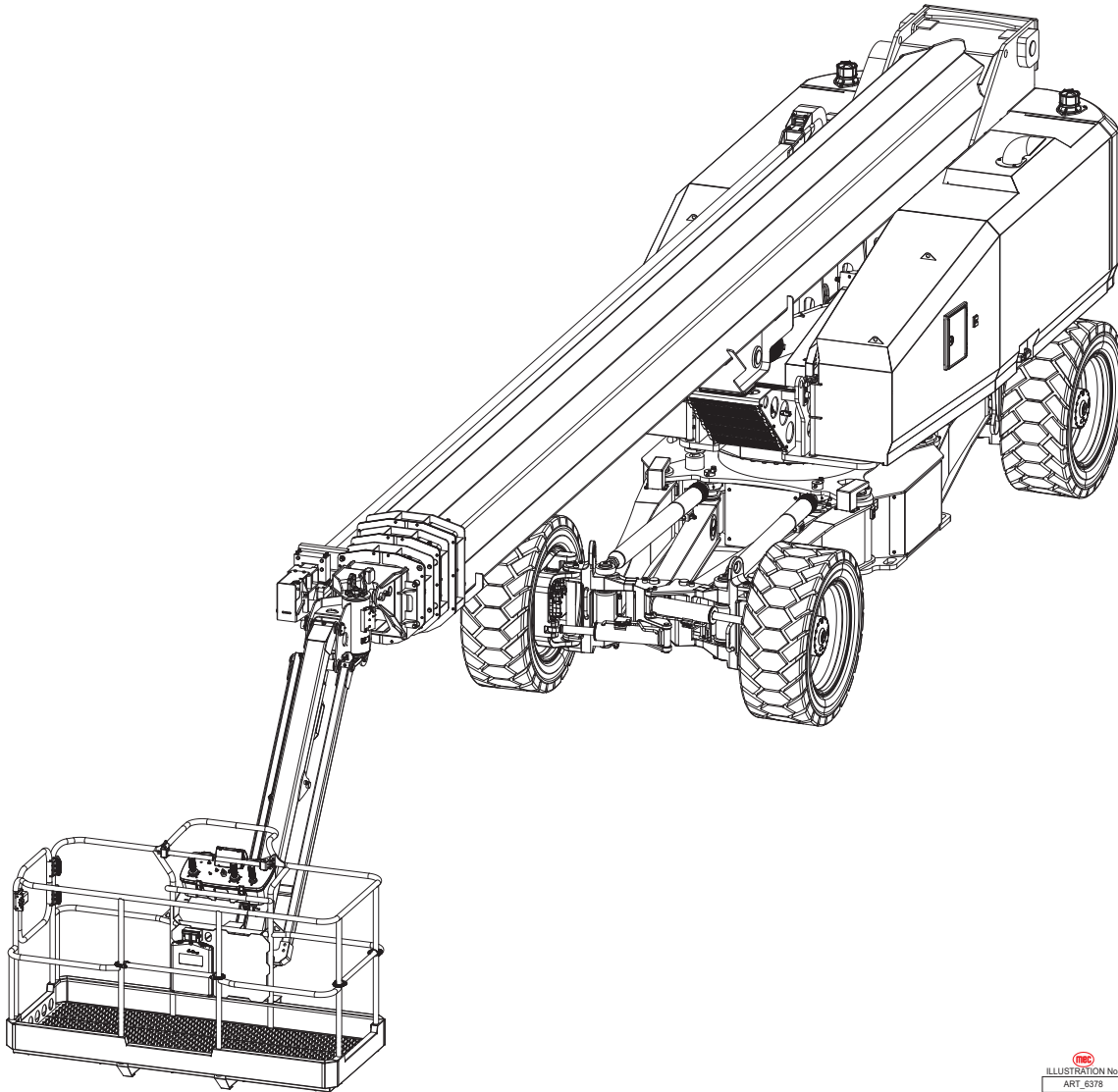

Operator's Manual

135-RJ



MEC
ILLUSTRATION No.
ART_8378

Meets requirements of ANSI A92.20-2020 and CSA B354.6-2019.
Serial Number Range 15100000 - Up

Part # 96908
February 2025

Revision History

Date	Reason for Update
February 2025	New Release



MEC Aerial Work Platforms

1401 S. Madera Avenue, Kerman, CA 93630 USA
Toll Free: 1-877-632-5438
Phone: 1-559-842-1500
Fax: 1-559-842-1520
info@MECawp.com
www.MECawp.com



Table of Contents

Section 1 - Introduction	1
<i>Introduction</i>	1
Section 2 - Safety	2
<i>Safety</i>	2
<i>Safety Alert Symbols & Fall Protection</i>	3
Section 3 - Specifications	4
<i>Specifications</i>	4
Section 4 - Hazards	5
<i>Electrocution Hazard</i>	5
<i>Tip-over Hazards</i>	8
<i>Fall & Collision Hazards</i>	10
<i>Additional Safety Hazards</i>	11
Section 5 - Controls & Components	12
<i>Component Locations</i>	12
<i>Platform Controls</i>	13
<i>Base Controls</i>	17
Section 6 - Workplace Inspection	20
<i>Workplace Inspection</i>	20
Section 7 - Operating Instructions & Pre-Operation Function Tests	21
<i>Operating Instructions & Pre-Operation Function Tests</i>	21
<i>Base Controls Operation & Pre-Operation Functions Test</i>	23
<i>Platform Control Operation & Pre-Operation Functions Test</i>	27
<i>Drive Control Lever Operation</i>	30
<i>Auxiliary Power System & Test</i>	35
Section 8 - Maintenance	37
<i>Maintenance</i>	37
<i>Pre-Start Inspection Checklist</i>	39
<i>Frequent Inspection Checklist</i>	40
<i>Maintenance Inspection Report</i>	41
<i>Lubrication</i>	42
Section 9 - Troubleshooting	43
<i>Troubleshooting</i>	43
Section 10 - Decals	44
<i>Decals</i>	44
<i>Serial Plate</i>	47
Section 11 - Transport and Lifting Instructions	48
<i>Transport and Lifting Instructions</i>	48

Introduction

This Operator's Manual has been designed to provide you, the owner, user or operator, with the instructions and operating procedures essential to properly and safely operate your MEC Aerial Work Platform for positioning personnel, along with their necessary tools and materials, to overhead work locations.

This Operator's Manual and other manuals provided by MEC on the machine must be read and understood prior to operating your MEC Aerial Work Platform. The operator should not accept operating responsibility until he/she has read and understands the operator's manual as well as having operated the MEC Aerial Work Platform under supervision of an authorized, trained and qualified operator.

 **DANGER**

It is essential that the operator of the aerial work platform is not alone at the workplace during operation.

Modifications of this machine from the original design and specifications without written permission from MEC are strictly forbidden. A modification may compromise the safety of the machine, subjecting the platform occupants and personal around the machine to serious injury or death.

Your MEC Aerial Work Platform has been designed, built, and tested to provide safe, dependable service. Only authorized, trained and qualified personnel shall be allowed to operate or service the machine.

MEC, as manufacturer, has no direct control over machine application and operation. Proper safety practices are the responsibility of the owner, user and operator.

If there is a question on application and/or operation contact:



MEC Aerial Work Platforms

1401 S. Madera Avenue, Kerman, CA 93630 USA
Toll Free: 1-877-632-5438
Phone: 1-559-842-1500
Fax: 1-559-842-1520
info@MECawp.com
www.MECawp.com

Safety

DO NOT operate this machine until you have read and understood this manual, have performed the Workplace Inspection, Pre-Start Inspection and Routine Maintenance, and have completed all the test operations detailed in the Operating Instructions section.

Failure to read, understand and follow all safety rules, warnings, and instructions could result in serious injury or death. For your safety and the safety of those around you, you must operate your machine as instructed in this manual.

MEC designs aerial work platforms to safely and reliably position personnel, along with their necessary tools and materials, at overhead work locations. The owner/user/operator of the machine should not accept responsibility for the operation of the machine unless properly trained.

ANSI and other applicable standards identify requirements of all parties who may be involved with self-propelled elevating work platforms. The Manual of Responsibilities is considered a part of this machine and can be found in the manual compartment, located at the platform control station. To ensure safe use of machine, inspections and training specified in ANSI/SIA A92.22 & A92.24 must be performed at designated intervals as prescribed.



This product can expose you to chemicals known to the State of California to cause cancer and birth defects or other reproductive harm. For more information go to www.p65warnings.ca.gov.

Safety Alert Symbols & Fall Protection

MEC manuals and decals use symbols, colors and signal words to help you recognize important safety, operation and maintenance information.



RED and the word **DANGER** – Indicates an imminently hazardous situation which, if not avoided, will result in death or serious injury.



ORANGE and the word **WARNING** – Indicates a potentially hazardous situation which, if not avoided, could result in death or serious injury.



YELLOW with alert symbol and the word **CAUTION** – Indicates a potentially hazardous situation which, if not avoided, may result in minor or moderate injury.



YELLOW without alert symbol and the word **CAUTION** – Indicates a potentially hazardous situation which, if not avoided, may result in property damage.



GREEN and the word **NOTICE** – Indicates operation or maintenance information.

Fall Protection

Personal fall protection equipment (PFPE) is required when operating this machine.

All personal fall protection equipment (PFPE) must comply with employer and job site rules and applicable governmental regulations, and must be inspected and used in accordance with the personal fall protection equipment (PFPE) manufacturer's instructions.

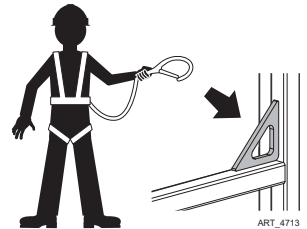

ALWAYS wear approved fall protection, properly attached to a designated anchor point, when operating the machine.

DO NOT attach more than one lanyard per anchor point.

Specifications

Maximum Working Height		141.5 feet	43.15 meters
Maximum Working Radius		82.02 feet	25.0 meters
Maximum Platform Height ¹		135 feet	41.15 meters
Maximum Platform Radius		80.05 feet	24.4 meters
Maximum Drive Height		135 feet	41.15 meters
Overall Length, Stowed Position		39.2 feet	11.96 meters
Overall Width, Stowed Position		7.8 feet	2.4 meters
Overall Width, Axles Deployed		14.7 feet	4.49 meters
Overall Height, Stowed Position		9.2 feet	2.83 meters
Platform Lift Capacity	Unrestricted	600 pounds	272 kilograms
	Restricted	900 pounds	408 kilograms
Maximum Occupants		2 Person	
Platform Details	Width	7.5 feet	2.3 meters
	Depth	3.2 feet	1 meter
	Entry	1 End Swing Gate, 2 Slide Bar Entries	
Gradeability	Stowed, Downhill	45% (24.2°)	
	Stowed, Uphill	45% (24.2°)	
Turntable Rotation		360° Continuous	
Maximum Main Boom Up Angle		77.5°	
Jib Horizontal Range	Working	130°	
	Stowed	220°	
Jib Vertical Range		135°	
Platform Rotation		180° (90° Each Side)	
Tail Swing, Axles Deployed		3.5 feet	1.07 meters
Tail Swing, Axles Retracted		7.4 feet	2.28 meters
Wheel Base, Axles Deployed		14.6 feet	4.48 meters
Wheel Base, Axles Retracted		15.7 feet	4.8 meters
Machine Weight ² (Unloaded)		44,775 pounds	20,310 kilograms
Maximum Wind Speed		28mph	12.5m/sec (45 km/h)
Ground Clearance		1.3 feet	0.4 meters
Engine		74 HP Deutz TD 2.9-L4	
Fuel Type		Diesel	
Fuel Capacity		39.6 gallons	150 liters
Hydraulic Fluid Capacity		60.7 gallons	230 liters
<p>Meets requirements of ANSI A92.20-2020 and CSA B354.6-2019. Allowable ambient temperature range: -20°F to 120°F (-29°C to 49°C). Consult with MEC for operation outside of this range. ¹ Working Height adds 6 feet (2 meters) to platform height. ² Weight may increase with certain options.</p>			

Electrocution Hazard

ELECTROCUTION HAZARD! THIS MACHINE IS NOT INSULATED!

DEATH OR SERIOUS INJURY will result from contact with or inadequate clearance from any electrically charged conductor.



You must maintain a CLEARANCE OF AT LEAST 10 FEET (3.05 meters) between any part of the machine, or its load, and any electrical line or apparatus carrying over 300 Volts up to 50,000 Volts. One foot (30.5 centimeters) additional clearance is required for every additional 30,000 Volts.

Observe Minimum Safe Approach Distance.

This machine is **not** electrically insulated and will not provide protection from contact with or proximity to electrical current.

Maintain safe distances from electrical power lines and apparatus in accordance with applicable government regulations and the following chart:

Voltage	Minimum Safe Approach Distance	
	Feet	Meters
Phase to Phase		
0 Volts to 300 Volts	Avoid Contact	
Over 300V to 50kv	10ft	3.1m
Over 50KV to 200KV	15ft	4.6m
Over 200KV to 350KV	20ft	6.1m
Over 350KV to 500KV	25ft	7.6m
Over 500KV to 750KV	35ft	10.7m
Over 750KV to 1000KV	45ft	13.7m



Allow for platform movement, electrical line sway or sag and beware of strong or gusty winds.

Keep away from the machine if it contacts energized power lines. Personnel on the ground or in the platform must not touch or operate the machine until energized power lines are shut off.

Do not use the machine as a ground for welding.

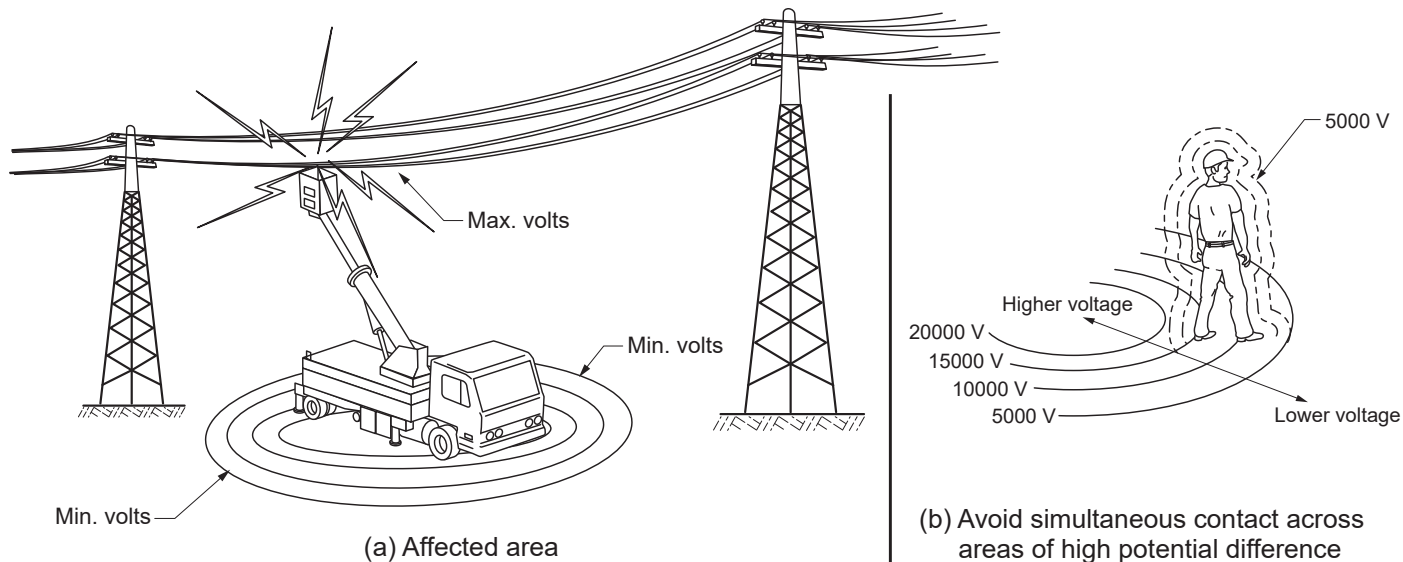

CLEARANCES FROM LIVE AERIAL CONDUCTORS

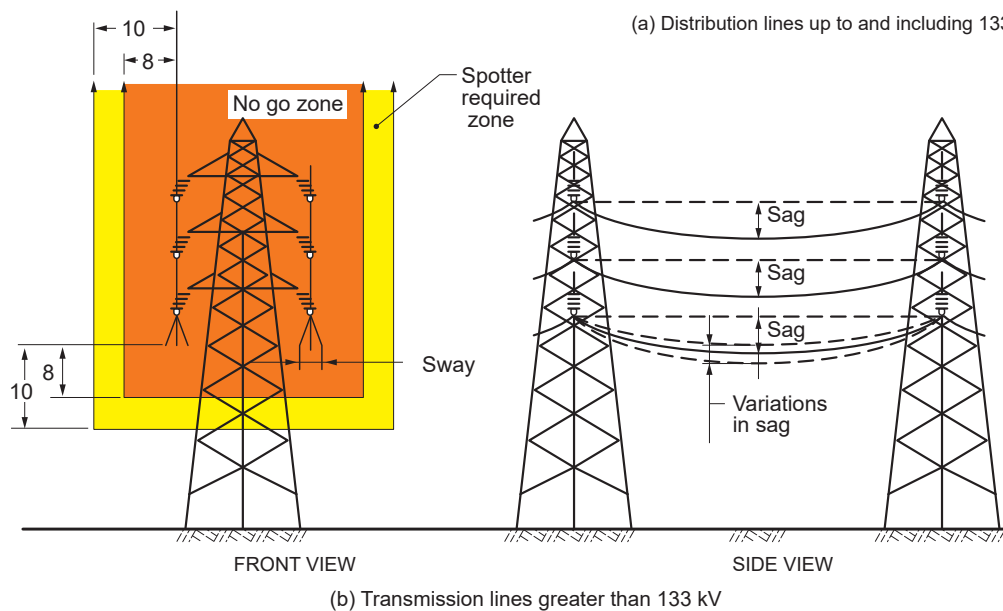
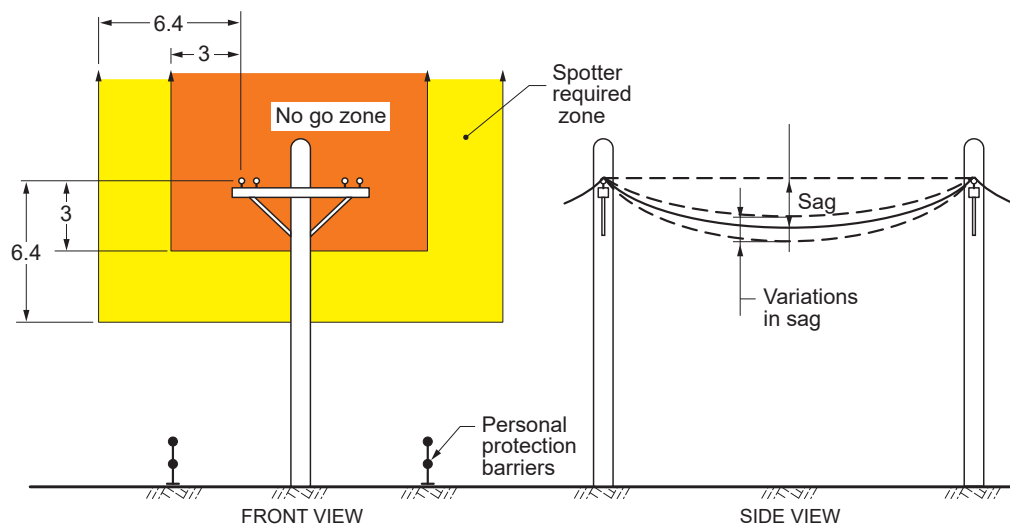

LEGEND

- = No shading, in the front views, indicates no proximity requirements
- = Light shading indicates spotter is required
- = Heavy shading indicates the NO GO ZONE

When working in the area of energized conductors the user shall direct and the operator shall comply with the requirements to:

- 1) Stay at least 10 feet (3.05 meters) away from power lines with any part of their body, conductive object or any part of the MEWP (Mobile Elevating Work Platform).
- 2) If work requires working nearer than 10 feet (3.05 meters), stop and consult a qualified person with respect to electrical transmission and distribution to have appropriate measures taken (such as de-energizing and grounding).
- 3) If there is a question that the power lines may carry more than 50kV, consult a qualified person with respect to electrical transmission and distribution before proceeding.
- 4) If working or approaching closer than explained above, it shall only be done by a qualified person with respect to electrical transmission and distribution. Only qualified persons may work on electric circuit parts or equipment that has not been de-energized. Such persons shall be capable of working safely on energized circuits and shall be familiar with the proper use of special precautionary techniques, personal protective equipment, insulating and shielding materials and insulated tools.

Tip-over Hazards

DO NOT exceed the maximum platform capacity. The weight of options and accessories will reduce the rated platform capacity and must be factored into the total platform load. Refer to the decals on the options or contact MEC.

Driving: DO NOT drive the machine on a slope that exceeds the maximum uphill or downhill slope rating. Slope rating applies to machines in the stowed position.

Driving in stowed position: Use extreme care and reduce speed when driving across uneven terrain, debris, unstable or slippery surfaces, and near holes or drop-offs.

Driving with the platform elevated: DO NOT drive on or near uneven terrain, unstable surfaces, curbs, drop-offs or other hazardous conditions.

DO NOT elevate the platform when the machine is on a surface that is soft and/or on a slope.

STOP ALL MOVEMENT if the tilt alarm sounds when the platform is raised. Refer to page 29 for instructions.

Ensure that all tires are in good condition and lug nuts are properly torqued.

DO NOT push off or pull toward any object outside the platform. DO NOT push the machine or other objects with the platform. DO NOT contact adjacent structures with the platform. DO NOT tie the platform to adjacent structures.

Maximum Allowable Side Force: 100lbs (445N).

NEVER transport tools and materials unless they are firmly secured. Secure all tools and loose materials. DO NOT carry materials or tools on the guardrails. DO NOT allow tools, supplies or any items to extend outside the platform.

DO NOT elevate the platform when wind speeds are in excess of 28mph (12.5m/s). If wind speeds exceed 28mph (12.5m/s) when the platform is elevated, carefully lower the platform and discontinue operation.

DO NOT increase the surface area of the platform (i.e. cover the rails with tarp or plywood). Increased surface area exposed to the wind will decrease machine stability.

NEVER modify or alter the work platform without written permission from MEC.

DO NOT attach overhanging loads or use the machine as a crane. DO NOT place loads outside the platform perimeter. Do not allow anything (hoses, cords, wires, ropes, etc.) to hang from the platform.



NEVER alter or disable any machine components.

DO NOT replace any part of the machine with anything except MEC-supplied or MEC-approved parts.

NEVER use ladders or scaffolds in the platform or allow them to touch any part of the machine.

NEVER use the machine on a moving or mobile surface or vehicle.

Fall & Collision Hazards

Fall Hazards

DO NOT sit, stand or climb on the platform guard rails. Maintain a firm footing on the platform floor at all times.

Keep the platform floor clear of debris.

DO NOT fasten a fall restraint lanyard or fall arrest lanyard or fall arrest to an adjacent structure.

Ensure that all gates are properly closed and secured before operating the machine.

Operators must comply with employer and job site rules and governmental regulations regarding the use of Personal Fall Protective Equipment.

DO NOT exit the platform when elevated.



DO NOT CLIMB ON RAILS



DO NOT ENTER OR EXIT PLATFORM WHEN ELEVATED

Collision Hazards

ALWAYS check over, under and around the machine for personnel, structures and obstructions before activating any control function and continue to watch for hazards while operating the machine.

Check path before moving for equipment, materials or other obstructions.

Check for overhead obstructions before moving.

DO NOT place the boom or platform against another structure.

Check path before moving for crushing hazards when holding the platform rail.

Reduce travel speed when moving the machine on slopes, when near personnel and obstacles, or when surface conditions are wet, slippery or otherwise limiting.

DO NOT operate in the path of any crane unless the controls of the crane have been locked out and/or precautions have been taken to prevent any possible collision.

Stunt driving and horseplay are PROHIBITED.

Check for personnel and obstructions below the platform when lowering the platform.

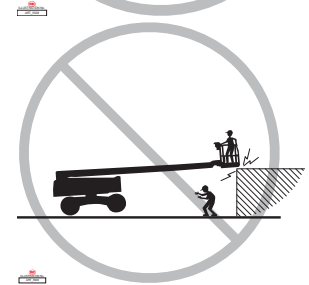

Additional Safety Hazards

Explosion and Fire Hazards

- DO NOT operate the machine in hazardous locations or locations where potentially flammable or explosive gases or particles may be present.

Damaged Machine Hazards

- Conduct a thorough pre-start inspection of the machine and test all functions before each work shift to check for damage, malfunction and unauthorized modification. Tag and remove a damaged, malfunctioning or modified machine from service. DO NOT use a damaged, malfunctioning or modified machine.
- Routine maintenance must be performed by the operator before each work shift. Scheduled maintenance must be performed by a qualified service technician at scheduled intervals. Tag and remove from service any machine that has not had scheduled preventative maintenance performed.
- Check that all safety and instructional decals are in place and undamaged.
- Check that the operator's, safety and responsibilities manuals are present in the storage container located in the platform. All manuals must be complete, undamaged and readable.

Bodily Injury Hazards

- DO NOT operate the machine when there is a hydraulic fluid or air leak. Hydraulic fluid or air under pressure can penetrate and burn skin, damage eyes, and may cause serious injury, blindness, and death. Repair leaks immediately. Fluid leaks under pressure may not always be visible. Check for pin hole leaks with a piece of cardboard, not your hand.
- All compartments must remain closed and secure during machine operation. Improper contact with components under any cover will cause serious injury. Only trained maintenance personnel should access compartments. The operator should only access a compartment when performing pre-operation inspection.

Weld Line to Platform Safety (If Equipped)

- Read, understand and follow all warnings and instructions provided with the welding power unit.
- DO NOT connect weld leads or cables unless the welding power unit is turned off at the platform controls.
- DO NOT operate unless the weld cables are properly connected.
- DO NOT connect the ground lead to the platform. Do not use any part of the machine as a ground for welding.
- DO NOT hang wires or cables over guardrails or suspend from the platform.

Battery Safety - Burn Hazards

- Batteries contain acid. Always wear protective clothing and eye wear when working with batteries. Avoid spilling or contacting battery acid. Neutralize battery acid spills with baking soda and water.

Battery Safety - Explosion Hazard

- Keep sparks, flame and lighted tobacco away from batteries. Batteries emit explosive gas.

Battery Safety - Electrocution Hazard

- Avoid contact with electrical terminals.

Component Locations

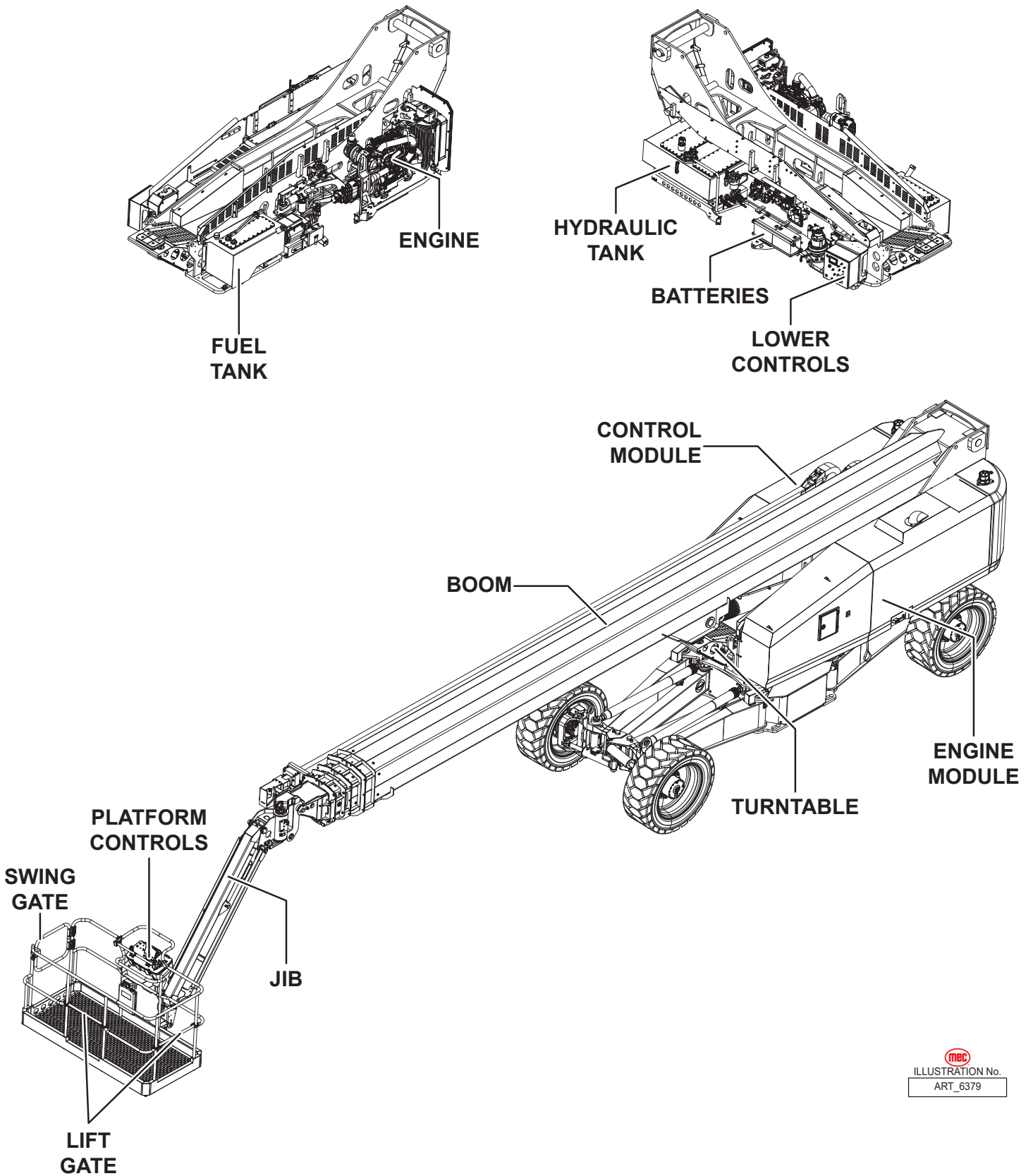
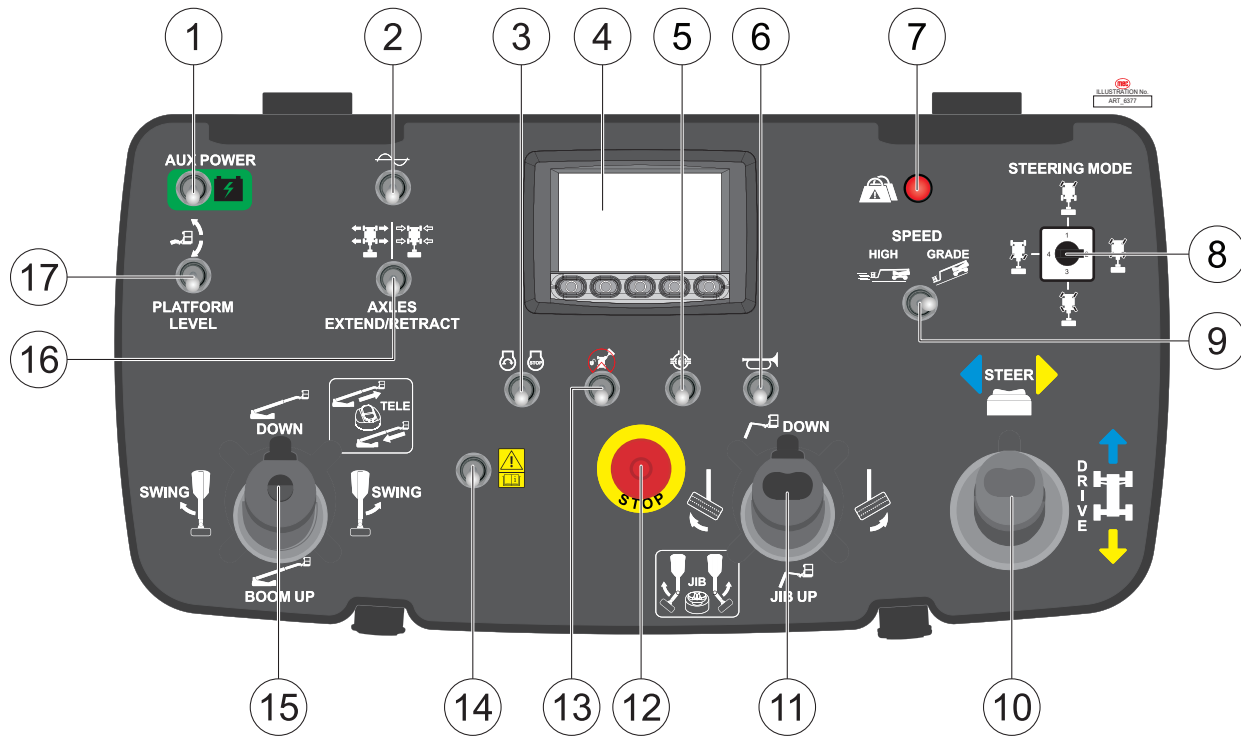



ILLUSTRATION No.
ART_6379

Platform Controls



WARNING

ALWAYS check over, under and around the machine for personnel, structures and obstructions before activating any control function and continue to watch for hazards while operating the machine.

#	Controls	Description
1	Auxiliary Power Switch	If normal power fails, move the switch up and hold while using Telescopic Boom Retract and Boom Lower functions.
2	Generator Switch (Optional)	Move the switch up to engage optional AC generator.
3	Engine Start/Stop Button	Move this switch up to start the engine or to turn the engine off.
4	Diagnostics Panel	This panel contains the basic information for monitoring the working status of the boom. See page 15.
5	Differential Lock Switch	Pressing this switch activates the differential lock which increases the traction of the wheels on the rear axle.
6	Horn Button	Press the switch up to sound warning horn.
7	Overload Indicator Light	Light on indicates too much weight in the platform. An audible alarm will sound and all machine function will stop. Remove weight from the platform to restore function and continue.
8	Steering Mode Select Switch	Make sure to center the tires before switching steering modes! Use this switch to set the steering mode: <ul style="list-style-type: none"> • Top Position (1): Front 2-Wheel Steer -- Only the front two wheels steer. • Right Position (2): Crab Steer -- All four wheels turn in the same direction. • Bottom Position (3): 4-Wheel Steer -- The front and rear wheels steer in opposite directions. • Left Position (4): Rear 2-Wheel Steer -- Only the rear two wheels steer.
9	Speed/Torque Select Switch	Push this switch to the left for high speed drive. Push this switch to the right for high torque drive.

10	Drive/Steer Control Handle	Depending on the position of the turntable, the machine may move in unexpected directions when the Drive and Steer functions are activated. The color- and shape-coded arrows on the joystick decal correspond to similar arrow decals on the machine chassis. Be sure to check the arrows on the chassis before using the Drive or Steer functions.	
		Drive Function	Depress the enable bar on front of the control handle, then push the control handle forward or backward to drive the machine. The speed of movement is proportional to handle movement.
		Steer Function	Depress the enable bar on front of the control handle, then press the thumb switch on top of the control handle to steer left or right.
11	Jib/Platform Control Handle	Jib Lift/Lower Function	Depress the enable bar on front of the control handle, then push the control handle forward to lift the jib. The speed of movement is proportional to handle movement. Depress the enable bar on front of the control handle, then pull the control handle backward to lower the jib. The speed of movement is proportional to handle movement.
		Platform Rotate Function	Depress the enable bar on front of the control handle, then push the control handle right to rotate the platform counterclockwise. The speed of movement is proportional to handle movement. Depress the enable bar on front of the control handle, then push the control handle left to rotate the platform clockwise. The speed of movement is proportional to handle movement.
		Jib Rotate Function	Depress the enable bar on front of the control handle, then push the thumb switch on top of control handle left to rotate the jib clockwise. Depress the enable bar on front of the control handle, then push the thumb switch on top of control handle right to rotate the jib counterclockwise.
12	Emergency Stop Switch	Press the Emergency Stop switch at any time to stop all machine functions. Pull the switch out to reset it and resume machine operation.	
13	Turntable out of Center/ Drive Enable	The driving function is restricted when the turntable exceeds 30 degrees. Press and release this button to allow a 10 second window in which you can enable the Drive/Steer function in Low Speed mode. The operation will continue until you stop the function.	
14	Emergency Platform Bypass	This switch bypasses the e-stop circuit and allows the machine to power on without completing the emergency power loop. It is for emergency situations only!	
15	Boom/Turntable Control Handle	Turntable Rotate Function	Depress the enable bar on front of the control handle, then push the control handle to the left to rotate the turntable clockwise or right to rotate the turntable counterclockwise. The speed of movement is proportional to handle movement.
		Boom Lift/Lower Function	Depress the enable bar on front of the control handle, then push the control handle forward to elevate the boom. The speed of movement is proportional to handle movement. Depress the enable bar on front of the control handle, then pull the control handle backward to lower the boom. The speed of movement is proportional to handle movement.
		Boom Extend/Retract Function	Depress the enable bar on front of the control handle, then push the thumb switch on top of control handle back to extend the boom. Depress the enable bar on front of the control handle, then push the thumb switch forward to retract the boom.

16	Axle Extend/Retract Switch	<p>Axles extend outward and retract inward one pair at a time!</p> <p>Depress the enable bar on front of a control handle, then press and hold the switch left to extend the axles outward. First, one pair of wheels will steer inward then the axles will extend outward. Once the first pair of axles have fully extended outward, the next pair of axles will also repeat the process. Keep the switch pressed until the process is complete with a beep sound.</p> <p>Depress the enable bar on front of a control handle, then press and hold the switch right to retract the axles inward. First, one pair of wheels will steer inward then the axles will retract inward. Once the first pair of axles have fully retracted inward, the next pair of axles will also repeat the process. Keep the switch pressed until the process is complete with a beep sound.</p>
17	Platform Level Switch	<p>Depress the enable bar on front of one of the control handles, then move this switch up to manually level the platform upward or move this switch down to manually level the platform downward.</p>

Diagnostics Panel

This panel contains the basic information for monitoring operation of the boom.

Row “A” displays the pages and options available in the lower part of the screen and is controlled by the corresponding buttons on row “B”.

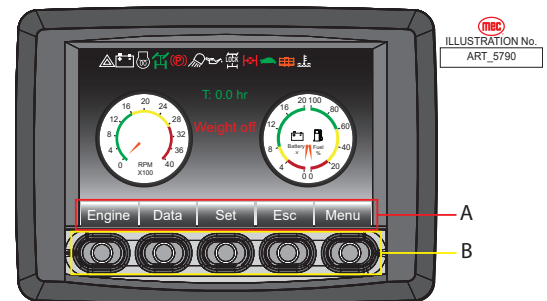

The upper band shows:

- Alarm indicator light
- Steering mode selection indicator light
- Parking brake active indicator light
- Differential lock active indicator light
- Front axle lock active indicator light
- Movement speed selection indicator light: slow/fast
- Controls position indicator light: ground/platform





The central band shows:

- The engine rev counter to the left hand side
- The number of working hours in the center, the batteries voltage, the fuel level and the engine fault code
- The engine oil pressure indicator and the engine water temperature indicator on the right hand side.

The bottom band shows the information shown on the pages that can be accessed:



- Engine data (RPM, drive torque percentage measured, coolant temperature, oil pressure, fuel consumption, operating hours, quantity of fuel used)
- Operational data (angular inclination of main boom, angular inclination of riser boom, inclination of the platform, inclination of the chassis on the horizontal plane, load measured on platform);
- Options settings (hydraulic preheat enable; Auto center steer; main boom retract confirmed; range extender auto start sw; engine hood open sw; main boom angle<30°confirmed)

The setting interface could be entered by pressing the setting button and holding for one second. The optional function can be turned on or off without a password, after entering the setting interface. The procedures are as follows:

1. Pressing “ / ” or “ / ” is used to choose the item separately. The chosen item would be shown in yellow background.
2. Pressing “On/Off” and holding on is used to turn on or off the corresponding function.
3. It returns back to main interface, when the button “Esc” is pressed.

FUNCTION PARAMETER	
Hydraulic Preheat Enable	OFF
Auto Center Steer	OFF
Main Boom Retract Confirmed	OFF
Range extender auto starts SW	OFF
Engine hood open SW	OFF
Main Boom Angle <30° Confirmed	OFF

ILLUSTRATION No.
ART_5790

 / +  / - On/Off Esc 

Base Controls

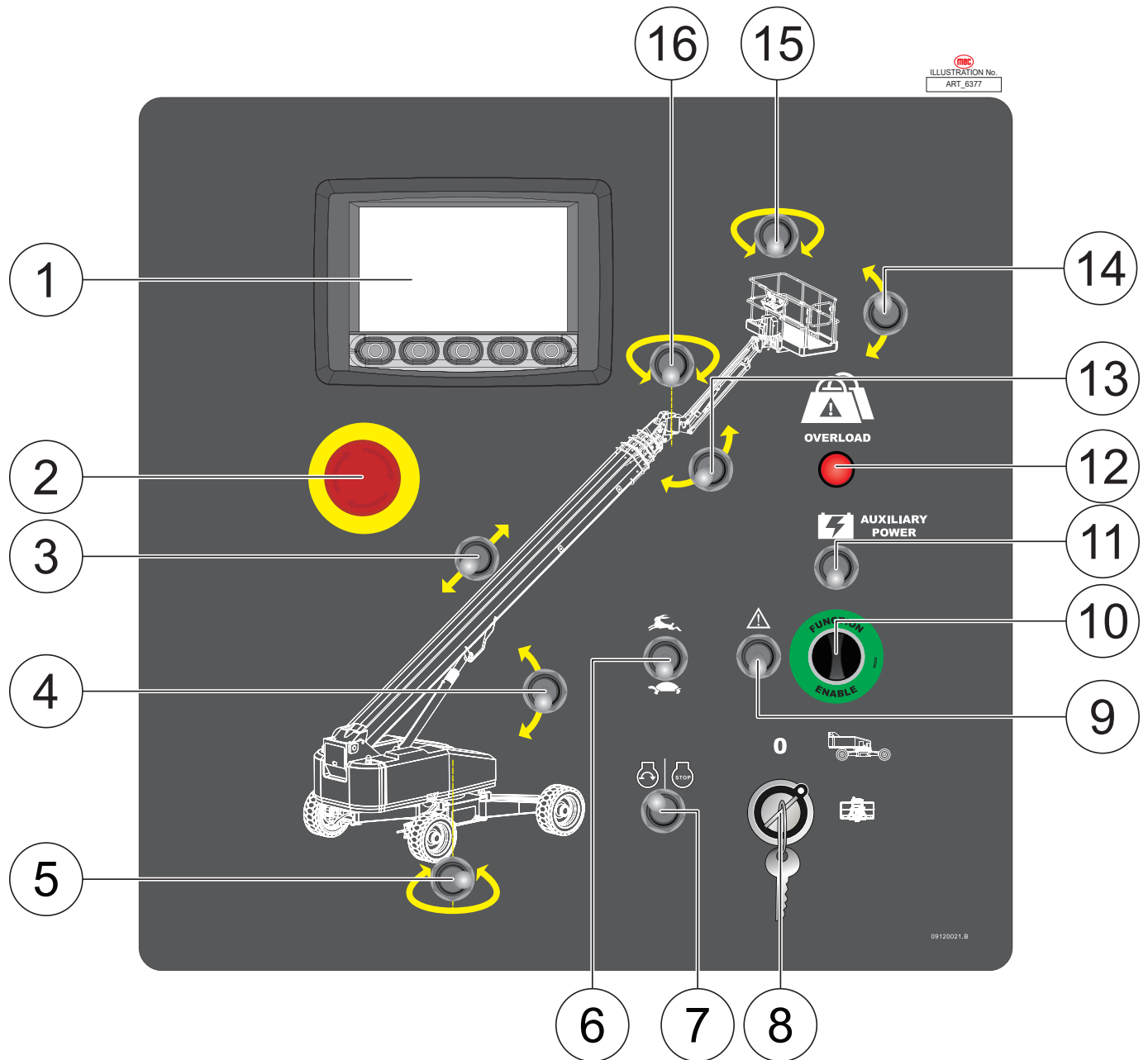

ALWAYS check over, under and around the machine for personnel, structures and obstructions before activating any control function and continue to watch for hazards while operating the machine.

#	Controls	Description
1	Diagnostics Panel	This panel contains the basic information for monitoring the working status of the boom. See page 18.
2	Emergency Stop Switch	Press the Emergency Stop switch at any time to stop all machine functions. Pull the switch out to reset it and resume machine operation.
3	Boom Extend/Retract Switch	Turn and hold the Function Enable Switch to enable operation. Move this switch up to extend the boom. Move this switch down to retract the boom.

4	Boom Lift/Lower Switch	Turn and hold the Function Enable Switch to enable operation. Move this switch up to lift the boom. Move this switch down to lower the boom.
5	Turntable Rotate Switch	Turn and hold the Function Enable Switch to enable operation. Move this switch left to rotate the turntable clockwise. Move this switch right to rotate the turntable counterclockwise.
6	Engine Speed Select Switch	Use this switch to set the engine speed when machine functions are enabled. Setting this switch to low idle speed allows the operator to move the machine slowly and precisely. Move this switch up for high idle speed and fast function speed. Move this switch down for low idle speed and slow function speed.
7	Engine Start/Stop Button	Move this switch up to start the engine or to turn the engine off.
8	Key Selector Switch	Off Select to stop operation from the lower and upper control panel.
		Platform Select to operate from the platform control panel.
		Base Select to operate from the lower control panel.
9	Emergency Platform Bypass	This switch bypasses the e-stop circuit and allows the machine to power on without completing the emergency power loop. It is for emergency situations only!
10	Function Enable Switch	Turn this switch right and hold to enable boom, turntable, and platform operations from the base controls.
11	Auxiliary Power Button	If normal power fails, move the switch up and hold while using functions to lower to the ground.
12	Overload Indicator Light	Light on indicates too much weight in the platform. An audible alarm will sound and all machine function will stop. Remove weight from the platform to restore function and continue.
13	Jib Lift/Lower Switch	Turn and hold the Function Enable Switch to enable operation. Move this switch up to lift the jib. Move this switch down to lower the jib.
14	Platform Level Switch	Turn and hold the Function Enable Switch to enable operation. Move this switch up to manually level the platform upward Move this switch down to manually level the platform downward.
15	Platform Rotate Switch	Turn and hold the Function Enable Switch to enable operation. Move this switch left to rotate the platform clockwise. Move this switch right to rotate the platform counterclockwise.
16	Jib Rotate Switch	Turn and hold the Function Enable Switch to enable operation. Move this switch left to rotate the jib clockwise. Move this switch right to rotate the jib counterclockwise.

Diagnostics Panel

This panel contains the basic information for monitoring operation of the boom.

Row “A” displays the pages and options available in the lower part of the screen and is controlled by the corresponding buttons on row “B”.

The upper band shows:

- Alarm indicator light
- Steering mode selection indicator light
- Parking brake active indicator light

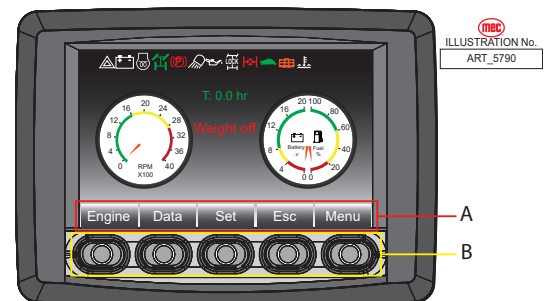

- Differential lock active indicator light
- Movement speed selection indicator light: slow/fast
- Controls position indicator light: ground/platform

The central band shows:

- The engine rev counter to the left hand side
- The number of working hours in the center, the batteries voltage, the fuel level and the engine fault code
- The engine oil pressure indicator and the engine water temperature indicator on the right hand side.

The bottom band shows the information shown on the pages that can be accessed:

- Engine data (RPM, drive torque percentage measured, coolant temperature, oil pressure, fuel consumption, operating hours, quantity of fuel used)
- Operational data (angular inclination of main boom, angular inclination of riser boom, inclination of the platform, inclination of the chassis on the horizontal plane, load measured on platform);
- Options settings (hydraulic preheat enable; Auto center steer; main boom retract confirmed; range extender auto start sw; engine hood open sw; main boom angle<30°confirmed)

The setting interface could be entered by pressing the setting button and holding for one second. The optional function can be turned on or off without a password, after entering the setting interface. The procedures are as follows:

1. Pressing “ / ” or “ / ” is used to choose the item separately. The chosen item would be shown in yellow background.
2. Pressing “On/Off” and holding on is used to turn on or off the corresponding function.
3. It returns back to main interface, when the button “Esc” is pressed.

FUNCTION PARAMETER	
Hydraulic Preheat Enable	OFF
Auto Center Steer	OFF
Main Boom Retract Confirmed	OFF
Range extender auto starts SW	OFF
Engine hood open SW	OFF
Main Boom Angle <30° Confirmed	OFF

ILLUSTRATION No.
ART_5790

Workplace Inspection

DO NOT operate this machine until you have read and understood this manual, have performed the **Workplace Inspection, Pre-Start Inspection and Routine Maintenance**, and have completed all the test operations detailed in the **Operating Instructions** section.

Inspect the workplace and determine whether the workplace is suitable for safe machine operation. Do this before moving the machine to the workplace.

Be sure the lift is the correct machine for the job.

Be aware of workplace conditions, and continue to watch for hazards while operating the machine.

ELECTROCUTION HAZARD! THIS MACHINE IS NOT INSULATED!

DEATH OR SERIOUS INJURY will result from contact with or inadequate clearance from any electrically charged conductor.



You must maintain a **CLEARANCE OF AT LEAST 10 FEET (3.05 meters)** between any part of the machine, or its load, and any electrical line or apparatus carrying over 300 Volts up to 50,000 Volts. One foot (30.5 centimeters) additional clearance is required for every additional 30,000 Volts.

Observe Minimum Safe Approach Distance.

Workplace Inspection

Before operating the machine, check the workplace for all possible hazards, including but not limited to:

- Drop-offs or holes, including those concealed by water, ice, mud, etc.
- Sloped, unstable or slippery surfaces
- Bumps, surface obstructions and debris
- Overhead obstructions and electrical conductors
- Other objects or equipment
- Hazardous locations and atmospheres
- Inadequate surface and support to withstand all load forces imposed by the machine
- Wind and weather conditions
- The presence of unauthorized personnel
- Other possible unsafe conditions

Operating Instructions & Pre-Operation Function Tests

DO NOT operate this machine until you have read and understood this manual, have performed the Workplace Inspection, Pre-Start Inspection and Routine Maintenance, and have completed all the test operations detailed in the Operating Instructions section.

This section provides instructions and tests for each function of machine operation. Follow all safety rules and instructions. The operator must conduct inspections and a Functions Test of the machine before each work shift to check that all machine systems are working properly.

Test the machine on a firm level surface with no debris, drop-offs, potholes or overhead obstructions. Perform each step outlined in this section.

This machine shall only be operated by trained and authorized personnel. If multiple operators use this machine, all must be trained, qualified and authorized to use it. New operators must perform a Pre-Start Inspection and Functions Test prior to operating the machine.

Operators must comply with all employer and job site rules and governmental regulations regarding the use of personal protective equipment – see Fall Protection on page 3.

DO NOT use a machine that is malfunctioning. If any function does not perform as described, tag the machine and remove for repair by a qualified service technician. After repairs are completed, a Pre-Start Inspection and Functions Test must be performed before using the machine.



ALWAYS check over, under and around the machine for personnel, structures and obstructions before activating any control function and continue to watch for hazards while operating the machine.

Prestart

Perform a Pre-start Inspection (see page 19). Check the red Emergency Stop buttons at both the lower control and platform controls, pull them both out to reset them.



ART_3353

Starting Engine from Base Controls

Be sure that the upper and lower Emergency Stop Switches are reset.

Lower Control Box: Turn Key Switch to CHASSIS.

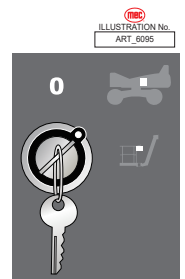
ILLUSTRATION No.
ART_6095

Lower Control Engine Start/Stop Button

Move this switch up to start the engine or to turn the engine off.

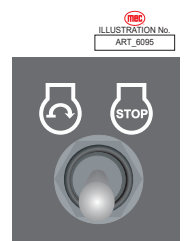
ILLUSTRATION No.
ART_6095

Lower Control Overload Indicator Light

Light on indicates too much weight in the platform. An audible alarm will sound and all machine function will stop. Remove weight from the platform to restore function and continue.

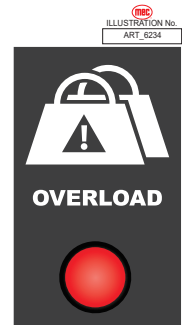

Starting Engine from Platform Controls

Be sure that the upper and lower Emergency Stop Switches are reset.

Lower Control Box: Turn Key Switch to PLATFORM.

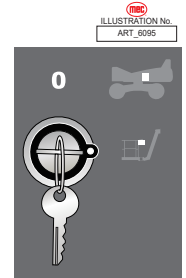

Upper Control Engine Start/Stop Button

Move this switch up to start the engine or to turn the engine off.

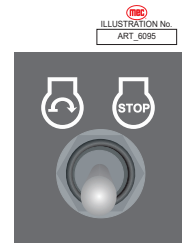

Upper Control Overload Indicator Light

Light on indicates too much weight in the platform. An audible alarm will sound and all machine function will stop. Remove weight from the platform to restore function and continue.



Base Controls Operation & Pre-Operation Functions Test

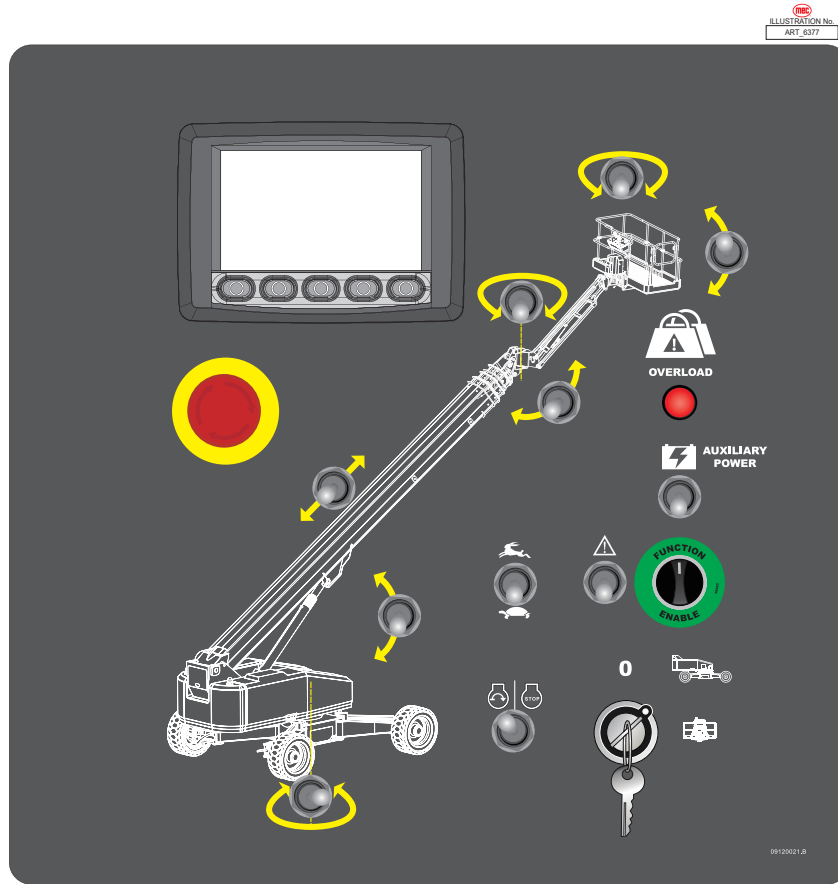

WARNING ALWAYS check over, under and around the machine for personnel, structures and obstructions before activating any control function and continue to watch for hazards while operating the machine.

Emergency Stop button

Both the upper and lower red Emergency Stop buttons must be pulled out for the machine to operate. Press the red Emergency Stop button at any time to stop all machine functions. Pull the switch out to reset it and resume machine operation.



Select BASE Operation

Be sure that the upper and lower Emergency Stop Switches are reset.

Lower Control Box: Turn Key Switch to CHASSIS.

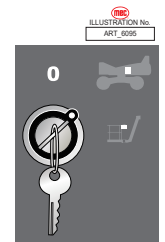

Function Enable Switch

Turn this switch right and hold to enable boom, turntable, and platform operations from the base controls.

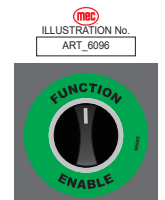

Engine Speed Select Switch

Use this switch to set the engine speed when functions are enabled. Setting this switch to low idle speed allows the operator to move the machine slowly and precisely.

- Move this switch up for high idle speed and fast function speed.
- Move this switch down for low idle speed and slow function speed.



Do not elevate the platform if the machine is not on a firm level surface.



When the axles are in the retracted position, many boom movements and the range of motion are restricted.

Boom Extend/Retract Switch

Move and hold the Extend/Retract switch on the base control panel to extend or retract the boom.

Test Operation

- Turn and hold the Function Enable Switch
- Extend boom until it stops. Boom should not exceed 3 feet (1 meter).
- Retract the boom until it stops. Boom should retract to minimum length.
- Releasing the switch will stop boom extension or retraction.
- Pressing the Emergency Stop Switch will stop boom extension or retraction.

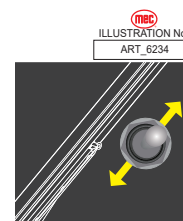

Boom Lift/Lower

Press and hold the Boom Lift/Lower switch on the base control panel to lift or lower the boom.

Test Operation

- Press and hold the Function Enable switch.
- Raise the boom until it stops. It should not exceed 10°.
- Lower the boom until it stops. Boom should rest on the turntable pad.
- Releasing the switch will stop Boom Lift/Lower function.
- Pressing the Emergency Stop Switch will stop boom lift/lower function.

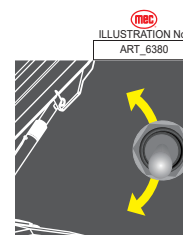

Jib Lift/Lower Switch

Press and hold the Jib Lift/Lower switch on the base control panel to lift or lower the jib.

Test Operation

- Press and hold the Function Enable switch.
- Raise the jib until it stops.
- Lower the jib until it stops.
- Releasing the switch will stop Jib Lift/Lower function.
- Pressing the Emergency Stop Switch will stop jib lift/lower function.

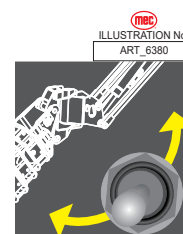

Jib Rotate Switch

Press and hold the Jib Rotate switch on the base control panel to rotate the Jib.

Test Operation

- Turn and hold the Function Enable Switch
- Push the switch left and right. The jib should rotate accordingly.
- Releasing the switch will stop turntable rotate function.
- Pressing the Emergency Stop Switch will stop turntable rotate function.

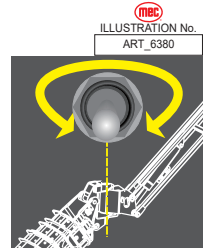

Platform Level Switch

The platform will automatically level as the boom is lifted or lowered. The Platform Level function allows manual level adjustment of the platform. Manual leveling may be used to adjust the platform within 5° of level.

- Press and hold the Platform Level switch on the base control panel to manually adjust the level of the platform.

Test Operation

- Press and hold the Function Enable switch.
- Push the switch up and down.
- The platform level should change accordingly. Releasing the switch will stop platform level function.
- Pressing the Emergency Stop Switch will stop platform level function.

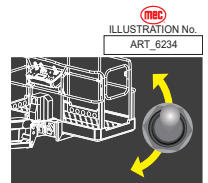

Platform Rotate Switch

Press and hold the Platform Rotate switch on the base control panel to rotate the platform.

Test Operation

- Press and hold the Function Enable switch.
- Push the switch left and right. The platform should rotate accordingly.
- Releasing the switch will stop platform rotate function.
- Pressing the Emergency Stop Switch will stop platform rotate function.

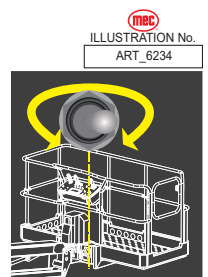

Turntable Rotate Switch

Press and hold the Turntable Rotate switch on the base control panel to rotate the turntable.

Test Operation

- Turn and hold the Function Enable Switch
- Push the switch left and right. The turntable should rotate accordingly.
- Releasing the switch will stop turntable rotate function.
- Pressing the Emergency Stop Switch will stop turntable rotate function.

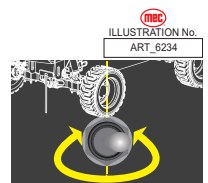

Overload Indicator Light

Light on indicates too much weight in the platform. An audible alarm will sound and all machine function will stop. Remove weight from the platform to restore function and continue.

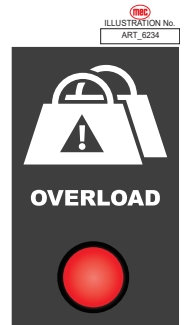

Platform Control Operation & Pre-Operation Functions Test



ILLUSTRATION No.
ART_5377



ALWAYS check over, under and around the machine for personnel, structures and obstructions before activating any control function and continue to watch for hazards while operating the machine.

Platform Control Function Enable Switch

Note: If any Function Enable trigger or button is depressed for seven (7) seconds without any function being activated, the Enable System times out and deactivates. Release the trigger or button and reengage to activate the Function Enable System.

The Drive function and boom functions are enabled by squeezing the trigger at the front of the appropriate control handle.

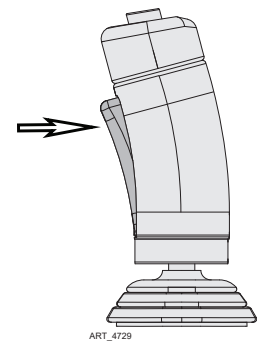

ART_4729

Emergency Stop

Both the upper and lower red Emergency Stop buttons must be pulled out for the machine to operate. Press the Emergency Stop button at any time to stop all machine functions. Pull the switch out to reset it and resume machine operation. Make sure the Emergency Stop button is pushed in whenever the machine is not in operation.



ART_3353

Activation of the Emergency Stop switch will apply brakes immediately.



This will cause sudden platform movement as the machine comes to an abrupt stop.

Brace yourself and secure objects on the platform during operation of machine.

Select PLATFORM Operation

Be sure that the upper and lower Emergency Stop Switches are reset.

Lower Control Box: Turn Key Switch to PLATFORM.

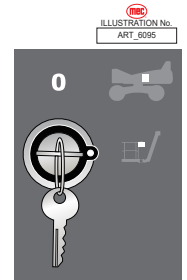

Entering The Platform

Personnel shall enter and exit the platform only at the Personnel Entry Gates, and only when the boom is fully retracted and lowered.

Ensure that all Personnel Entry Gates are properly closed and that the Swing Gate is latched in the closed position before operating the machine.

Personnel Entry Gates

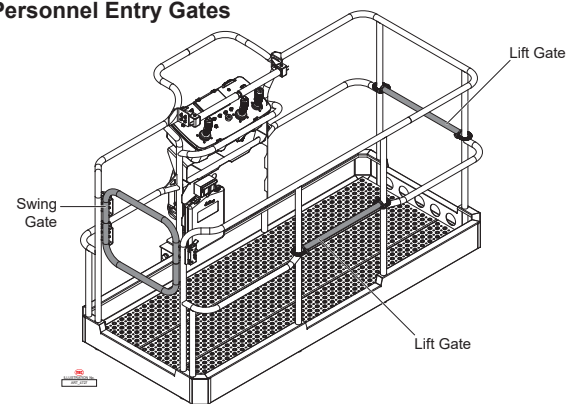

Secondary Guarding

1. As a safety feature, there are 2 yellow colored swinging bars positioned above the Platform controls. If one or both bars are pushed forward, all machine functions will stop immediately sounding an alarm.
2. If at any time one or both bars are depressed, evaluate the instance that caused the actuation and proceed accordingly with choice 3 or 4.
3. To reset the system, allow the bars to return to the natural centered position, return all control handles to neutral position and release all enable trigger switches. Normal operation may be resumed.
4. To enable limited operation while one or both bars are depressed, push up and hold the Emergency Platform Bypass switch (see illustration to right). While holding the Bypass switch, select the desired function and operate it in the normal procedure. Certain lift functions such as Boom Up, and Telescope out are not available in this Bypass mode.

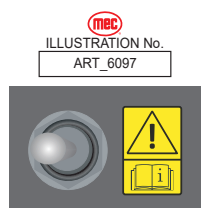
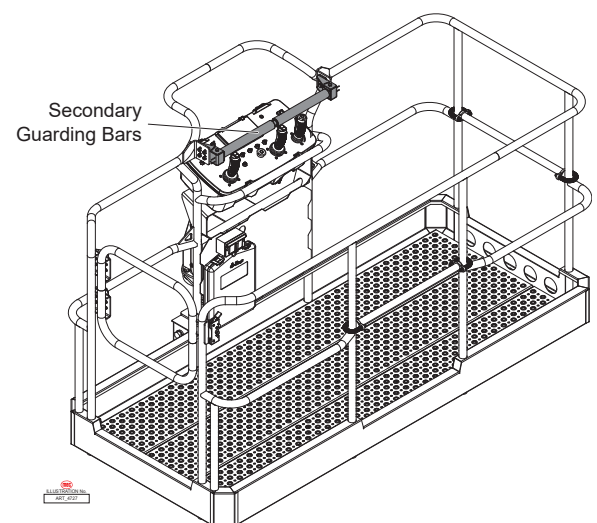

Emergency Platform Bypass Switch

Fall Protection

Personal fall protection equipment (PFPE) is required when operating this machine.

All personal fall protection equipment (PFPE) must comply with employer and job site rules and applicable governmental regulations, and must be inspected and used in accordance with the personal fall protection equipment (PFPE) manufacturer’s instructions.

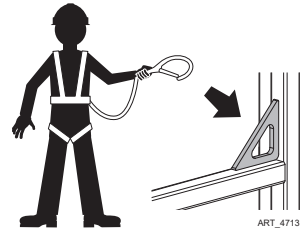

ALWAYS wear approved fall protection, properly attached to a designated anchor point, when operating the machine.

DO NOT attach more than one lanyard per anchor point.

Engine Start/Stop Switch

Enter the platform through one of the personnel entry gates. Close and secure the entry.

Move this switch up to start the engine or to turn the engine off.

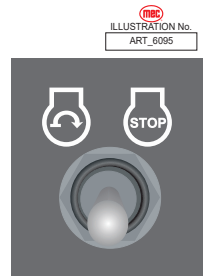

Horn Button

Press the Horn Button to verify proper operation.

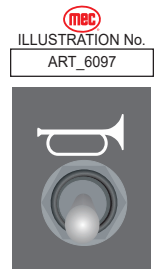

Tilt Warning



STOP ALL MOVEMENT if Tilt Alarm sounds.

On the display, a Tilt Warning and an alarm sounding indicates an unsafe condition.

- STOP ALL MOVEMENT. The machine is not level.
- Look at the diagram to determine the condition of the counterweight as it relates to the slope, then use extreme caution while following the instructions. DO NOT rotate the turntable while lowering.
- If the Tilt Alarm sounds while the counterweight is uphill, first retract the boom, then lower the boom.
- If the Tilt Alarm sounds while the counterweight is downhill, first lower the boom, then retract the boom.
- Move the machine to a firm, level surface before continuing operation.

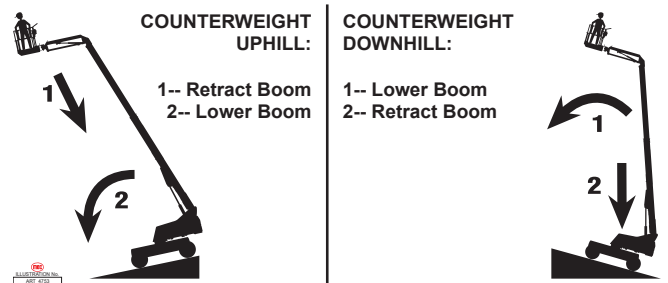

Drive Control Lever Operation

Depending on the orientation of the boom and chassis, the Drive and Steer functions may move the machine in directions opposite of the motion of the control handle. The color- and shape-coded arrows on the control handle decal correspond to similar arrow decals on the machine chassis (see illustrations). Be sure to check the arrows on the chassis before activating and using the Drive or Steer functions.

Drive Function speed is proportional and is controlled by the positional of the control handle. The further it is moved from the neutral (center) position, the faster the speed will be.

When the boom is elevated out of the stowed position, the maximum drive speed is reduced to 0.5mph (0.8km/h). Drive function speed is still fully proportional to the position of the drive control handle.

The control handle returns to the neutral (center) position when released. Steering Function is not proportional.

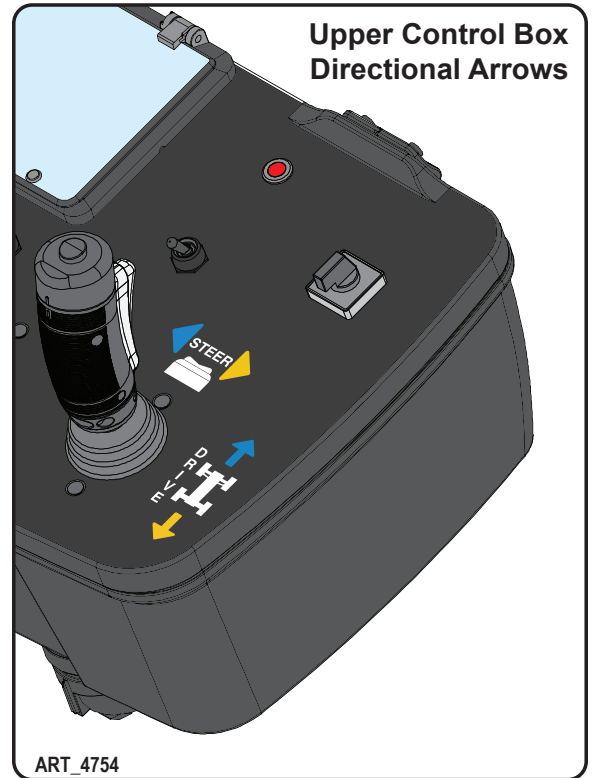

Note: The Steering Function does not automatically return the steering wheels to the centered position. Always check the position of the steering wheels before and during machine operation.

Test Operation

1. **Drive:** Squeeze the enable trigger, then move the control handle in the desired direction of movement. The further it is moved from the neutral (center) position, the faster the speed will be.
2. **Stop:** Return the control handle to the neutral (center) position. Releasing the control handle will also stop the machine. Releasing the trigger will result in a rapid stop.
 - Extend the boom approximately 3 feet (1 meter), then drive the machine. Speed should be reduced significantly from the fully-retracted, fully-lowered speed. Retract the boom.
 - Elevate the boom approximately 10°, then drive the machine. Speed should be reduced significantly from the fully-retracted, fully-lowered speed. Lower the boom.
3. **Steering:** Squeeze the enable trigger, then press the thumb switch on top of the control handle to steer in the desired direction.

Note: The Steering Function **does not** automatically return the steering wheels to the centered position. Stay alert to the position of the steering wheels before and during machine operation.

Steer Directional Arrows

Pay careful attention to the Chassis Steer arrows.

If the blue colored decals are on the right hand side, then the drive function will not be restricted if the turntable is in alignment.

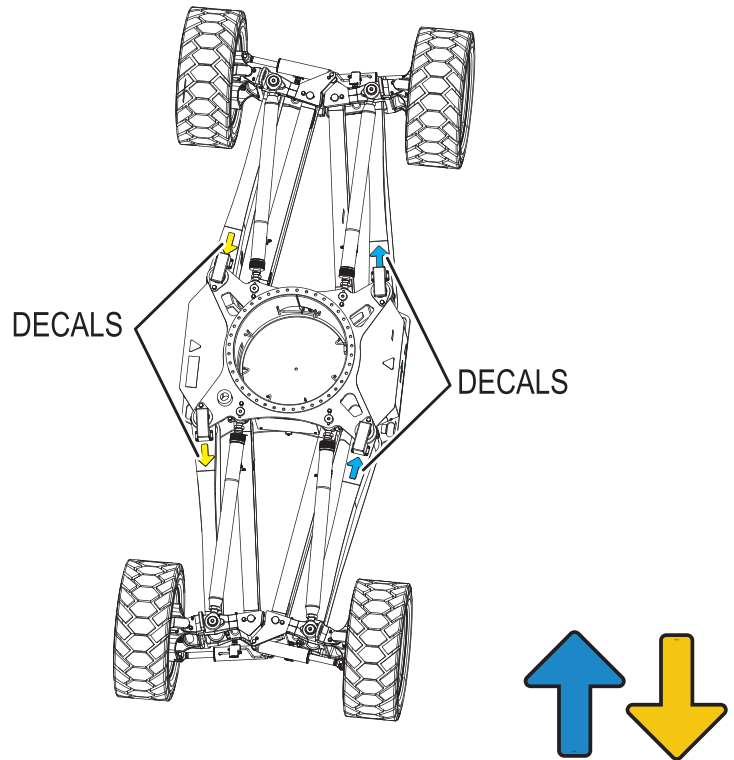

Upper Control Box

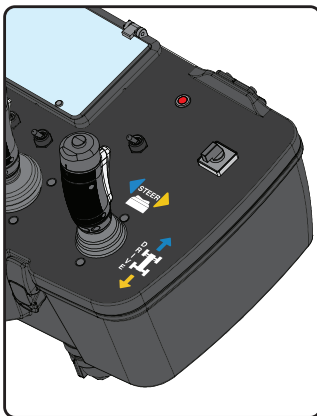

If the yellow colored decals are on the right hand side and the Drive Enable is used, the machine moves in the opposite direction of the Control Handle.

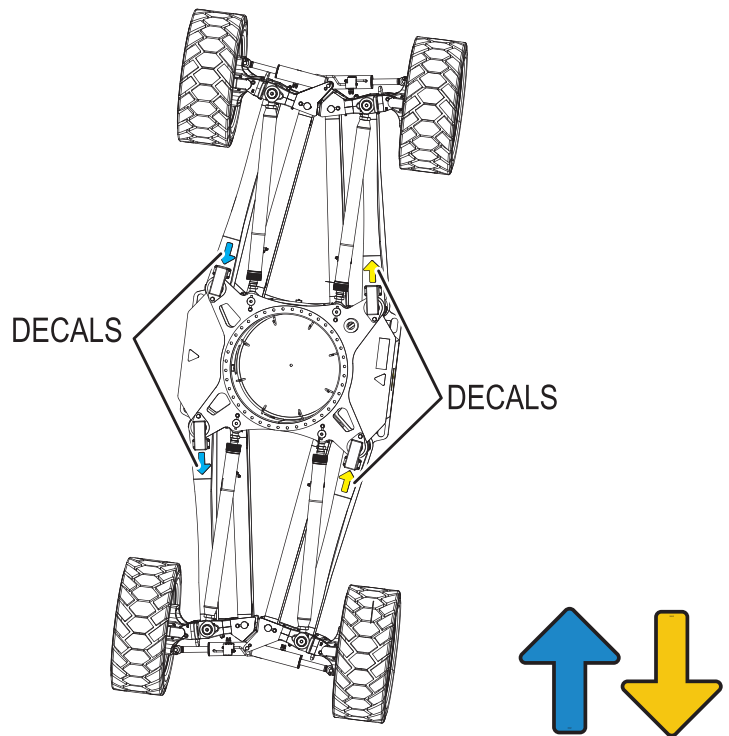
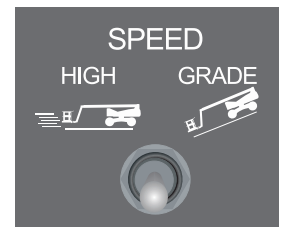



ILLUSTRATION No.
ART_4747

ILLUSTRATION No.
ART_6097

Speed/Torque Switch

Move this switch to the left for high speed drive. Push this switch to the right for high torque drive.



Axle Extend/Retract Switch



Axles extend outward and retract inward one pair at a time! When the axles are extending or retracting, the platform will sway! Be aware of your surroundings!

Test Operation

- **To test the Axle Extension/Retraction function:**
 - Depress the enable bar on front of a control handle, then press and hold the switch left to extend the axles outward. First, one pair of wheels will steer inward then the axles will extend outward. Once the first pair of axles have fully extended outward, the next pair of axles will also repeat the process. Keep the switch pressed until the process is complete with a beep sound.
 - Depress the enable bar on front of a control handle, then press and hold the switch right to retract the axles inward. First, one pair of wheels will steer inward then the axles will retract inward. Once the first pair of axles have fully retracted inward, the next pair of axles will also repeat the process. Keep the switch pressed until the process is complete with a beep sound.

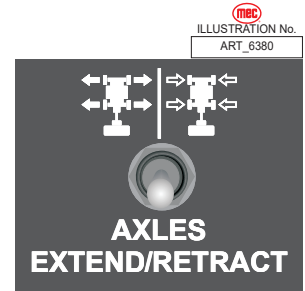

Boom Functions Control Handle

First extend the axles to allow full boom movement. This control handle controls the Boom Extend/Retract, Boom Lift/Lower and Turntable Rotate functions. The control handle is fully proportional for the Boom Lift/Lower and Turntable Rotate functions.

These functions are enabled by pressing the trigger on the front of the control handle.

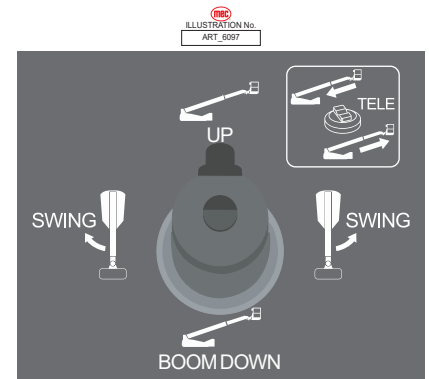

Test Operation

- **To test the Boom Extend/Retract function:**
 - Squeeze the enable trigger, then press and hold the thumb switch on top of the control handle rearward until the boom reaches full extension.
 - Squeeze the enable trigger, then press and hold the thumb switch forward to retract the boom.
- **To test the Boom Lift/Lower function:**
 - Squeeze the enable trigger, then push the control handle forward to lift the boom. Lift the boom completely.
 - Squeeze the enable trigger, then pull the control handle backward to lower the boom. Lower the boom to its stowed position.
- **To test the Turntable Rotate function:**
 - Squeeze the enable trigger, then push the control handle to the left to rotate the turntable clockwise.
 - Squeeze the enable trigger, then push the control handle to the right to rotate the turntable counterclockwise.

Platform Level Switch

The platform will automatically level as the boom is lifted or lowered. The Platform Level function allows manual level adjustment of the platform. Manual leveling may be used to adjust the platform within 5° of level.

Test Operation

- **To test the Platform Level function:**
 - Press and hold the Function Enable trigger on any control handle.
 - Push the Platform Level switch up or down to adjust the position of the platform.
 - Platform Level power is disabled upon exceeding 5° out of level when out of the stowed position. Power is allowed only to the direction that returns the platform toward level.



Platform/Jib Functions Control Handle

The Platform/Jib Functions control handle controls the Platform Rotate, Jib Lift/Lower functions. The control handle is fully proportional for Jib and Platform functions.

These functions are enabled by pressing the trigger on the front of the control handle.

Test Operation

- **To test the Jib Rotation function:**
 - Squeeze the enable bar, then push the thumb switch on top of control handle left to rotate the jib clockwise.
 - Squeeze the enable bar, then push the thumb switch on top of control handle right to rotate the jib counterclockwise.
- **To test the Jib Lift/Lower function:**
 - Squeeze the enable trigger, then push the control handle forward to raise the jib.
 - Squeeze the enable trigger, then pull the control handle backward to lower the jib.
- **To test the Platform Rotate function:**
 - Squeeze the enable trigger, then push the control handle left to turn the platform clockwise.
 - Squeeze the enable trigger, then push the control handle right to turn the platform counter clockwise.

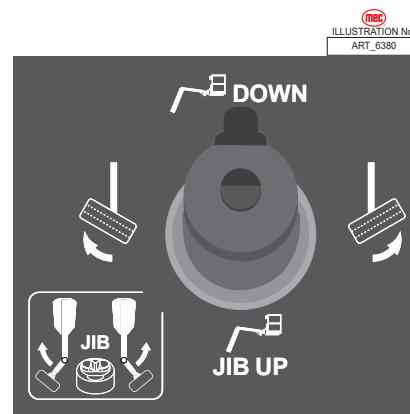

Steering Mode Select Switch

Four steering modes are available: Front 2-Wheel Steer, Crab Steer, 4-Wheel Steer, and Rear 2-Wheel Steer.

Note: Wheels do not automatically return to the centered position when switching steering modes!
Always check the position of the wheels before switching steering modes!

Test Operation

- Set Steering mode to the top position #1: Front 2-Wheel Steer. Squeeze the enable trigger, then press the thumb switch on top of the control handle. Only the front two wheels should turn. Return the wheels to the centered position.
- Set Steering mode to the right position #2: Crab Steer. Squeeze the enable trigger, then press the thumb switch on top of the control handle. All four wheels should turn in the same direction. Return the wheels to the centered position.
- Set Steering mode to the bottom position #3: 4-Wheel Steer. Squeeze the enable trigger, then press the thumb switch on top of the control handle. The front and rear wheels should turn in opposite directions. Return the wheels to the centered position.
- Set Steering mode to the left position #4: Rear 2-Wheel Steer. Squeeze the enable trigger, then press the thumb switch on top of the control handle. Only the rear two wheels should turn. Return the wheels to the centered position.

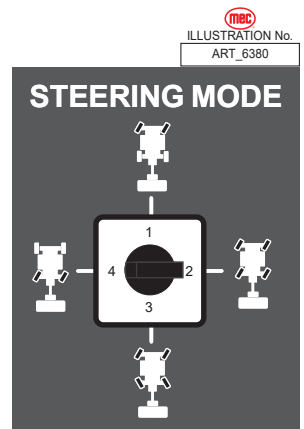

Upper Control - Turntable out of Center/Drive Enable Switch

The driving function is restricted when the turntable exceeds 30 degree out of centered position. Press and release this button to allow Drive/Steer function in Low Speed mode. The acknowledgment switch is valid for 10 seconds before beginning drive movement. The single touch of the switch is valid throughout the drive operation until the operation is completed.

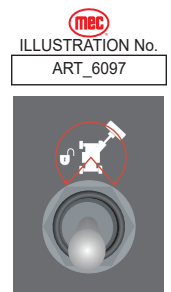

Shutdown Procedure

When finished with the machine, place the platform in the stowed position. Park the machine on a level surface.

Carefully exit the platform using a constant three (3) point dismount/grip.

Press the Emergency Stop Switch.

Turn the Selector Key Switch to the "0" position and remove the key to prevent unauthorized use. Always put the switch in "0" position when leaving the machine at the end of the work day.

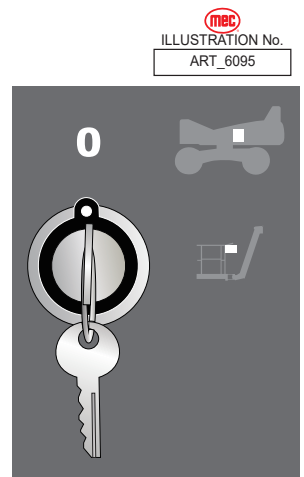

Auxiliary Power System & Test

If primary power fails while the platform is elevated, use the Auxiliary Power System to safely lower the platform.



Do not climb down the boom assembly or exit the platform while elevated.

ALWAYS check over, under and around the machine for personnel, structures and obstructions before activating any control function and continue to watch for hazards while operating the machine.

Platform Controls



Upper Auxiliary Power Switch

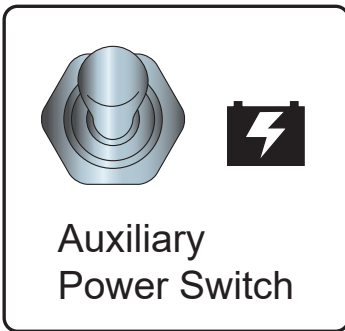

Base Controls

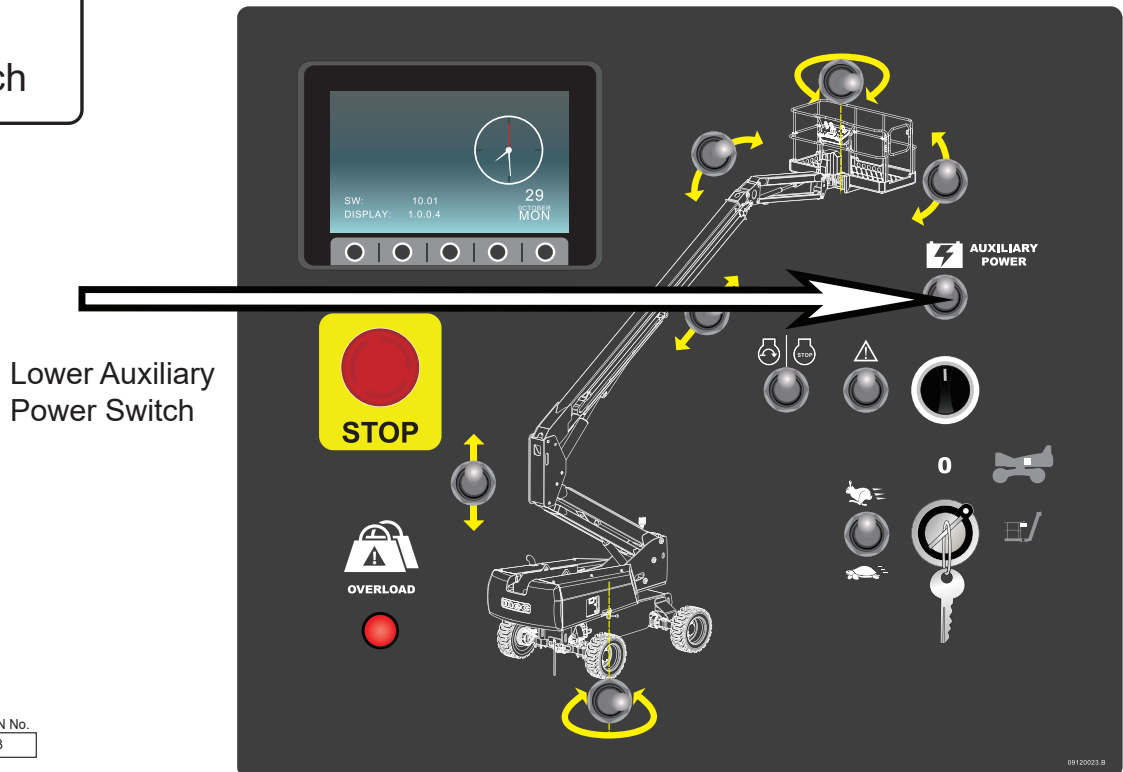

Lower Auxiliary Power Switch

The Auxiliary Power System is used to lower the platform in case of primary power failure. To lower the platform, activate the Auxiliary Power Switch to run the auxiliary hydraulic pump.

This function uses battery power from the auxiliary battery to lower the platform.

- Push and hold the Auxiliary Power Switch, then use the Boom Extend/Retract function to retract the boom.
- Continue to hold the Auxiliary Power Switch, then use the Boom Lift/Lower function to lower the boom.

Note: The Auxiliary Power System is disabled when the engine is running.

Note: The Auxiliary Power Switch serves as an enable switch. It is not necessary to use the primary function enable switch.

Test Operation

- Test the Auxiliary Power System from both control stations.
- Test any lift function for 5-10 seconds to verify proper operation.

Lower Control - Emergency Bypass Switch

This switch bypasses the e-stop circuit and allows the machine to power on without completing the emergency power loop. **This is for emergency situations only!**

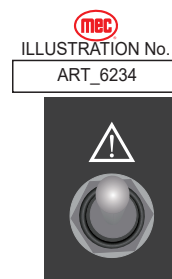

Upper Control - Emergency Bypass Switch

This switch bypasses the e-stop circuit and allows the machine to power on without completing the emergency power loop. **This is for emergency situations only!**



Maintenance

DO NOT operate this machine until you have read and understood this manual, have performed the Workplace Inspection, Pre-Start Inspection and Routine Maintenance, and have completed all the test operations detailed in the Operating Instructions section.

Tag and remove a damaged, malfunctioning or modified machine from service. DO NOT use a damaged, malfunctioning or modified machine.

Use the Pre-Start Inspection to determine what Routine Maintenance is required. The operator may perform only the routine maintenance items specified in this manual.

IMPORTANT: Scheduled maintenance inspection checklists are included in this manual for use only by qualified service technicians. Only qualified service technicians may perform repairs to the machine. After repairs are completed, the operator must perform a Pre-Start Inspection before proceeding to the Functions Test.



Hydraulic fluid under pressure can penetrate and burn skin, damage eyes, and may cause serious injury, blindness, and death. Repair leaks immediately. Fluid leaks under pressure may not always be visible. Check for pin hole leaks with a piece of cardboard, not your hand.



NEVER perform work under the boom assembly with the platform elevated without first supporting the boom assembly.

Failure to perform scheduled maintenance at recommended intervals may result in injury or death. Keep maintenance records current and accurate.

Immediately report any damage, defect, unauthorized modification or malfunction to your supervisor. Any defect must be repaired prior to continued use. DO NOT use a damaged, modified or malfunctioning machine.

DO NOT hang anything over any control handle at any time.



Never leave hydraulic components or hoses open. Plug all hoses and fitting immediately after disassembly to protect the system from outside contamination (including rain).

Never open a hydraulic system when there are contaminants in the air.

Always clean the surrounding area before opening hydraulic systems.

Use only recommended lubricants. Improper lubricants or incompatible lubricants may cause as much damage as no lubrication.



Watch for makeshift “fixes” which can jeopardize safety as well as lead to more costly repair.

Inspection and maintenance should be performed by qualified personnel familiar with the equipment.

Routine Maintenance

IMPORTANT: The operator may perform only maintenance items on the Pre-Start Inspection Checklist. Frequent and Annual maintenance must be performed by qualified service technicians.

Pre-Start Inspection

Perform routine maintenance as identified in the Pre-Start Inspection Checklist on page 39.

Frequent and Annual Maintenance

Frequent Inspection Checklists and Annual Inspection Reports must be completed by qualified service technicians trained and authorized to perform maintenance on this machine, and must be done in accordance with the procedures outlined in the service manual. Scheduled maintenance inspection checklists are included in this manual for use by qualified service technicians.

Machines that have been out of service for more than three months must have the Frequent Inspection Checklists completed before returning to service.

Pre-Start Inspection Checklist

The operator must conduct a Pre-Start Inspection of the machine before each work shift.

DO NOT use a damaged or malfunctioning machine.

	Check that the operator's manual and manual of responsibilities are in the storage container located on the platform.
	Perform a visual inspection of all machine components. Look for missing parts; torn or loose hoses; hydraulic fluid leaks; loose, torn or disconnected wires; damaged tires; etc.
	Check all structural components of the machine for cracked welds, corrosion and collision damage.
	Check the security and condition of the lanyard attachment points.
	Check all controls for any damage and proper function.
	Check all hoses and the cables for worn or chafed areas.
	Check the platform rails and sliding mid-rail entries for damage or modification. Check the swing gate for proper operation and latching.
	Check that all warning and instructional decals are legible and secure.
	Check the tires for damage.
	All structural components, pins and fasteners are present and properly tightened.
	Check for fluid leaks.
	Check hydraulic fluid level (check with platform fully lowered).
	Check engine oil level.
	Check engine coolant level at overflow bottle.
	Check fuel tank level.
	Secure all covers, panels and hoods.
	Ensure that all gates are properly closed and secured before operating the machine.

Date _____ Inspected By _____

Frequent Inspection Checklist



This checklist must be used at 3-month intervals or every 150 hours of machine use, whichever occurs first. Failure to do so could result in death or serious injury.

Frequent Maintenance Inspections should be conducted by qualified service technicians only. Photocopy this page for reuse. Keep inspections records up to date. Record and report all discrepancies to your supervisor.

Model Number _____ Serial Number _____ Hour Meter Reading _____

Perform all checks listed on Pre-Start Inspection.
Replace engine oil and filter after the first 100 hours of service.
See engine operator’s manual for other engine maintenance information.
Inspect the condition of hydraulic fluid in the reservoir. Oil should be a clear amber color.
Check battery electrolyte level and connections.
Check wheel lug nuts for proper torque (see Specifications).
Check if tires are leaning in or out.
Inspect all structure and pivot points for signs of wear and/or damage.
Check the pin joints and retaining rings for security.
Inspect the entire machine for signs of damage, broken welds, loose bolts, improper or makeshift repairs.
Check that the platform does not drift down with a full load.
Check all wire connections for tightness and corrosion.
Check the operation speeds to ensure they are within specified limits (see Specifications).
Check the Auxiliary Power System.
Clean and lubricate all push button switches with dry lubricant and ensure that the switches operate freely in all positions.
Check the tightness of the platform frame and the linkage pins.
Check the overall platform and guardrail component security.
Check the electrical mounting and hardware connections for security.
Check the steering kingpins for excessive play.

Additional maintenance requirements for severe conditions

	If the machine is used in very dusty, exceptionally hot or exceptionally cold conditions, replace hydraulic filter element and air filter element (under normal conditions replace every 6 months or 300 hours, whichever comes first).
--	---

Date _____ Inspected By _____



Maintenance Inspection Report

135-RJ Boom

Fleet Equipment Number _____ Date _____
 Inspector Name _____ Inspector Co. _____
 Model Number _____ Address _____
 Serial Number _____
 Hour Meter _____ Signature _____
 Machine Owner & address _____

Maintain all service records in accordance with ANSI A92.24-2019

- * Refer to the 135-RJ Service Manual maintenance section for required information before testing.
- * If an inspection receives an "N", remove from service. Once repaired, place an "R" in the box.
- * Refer to the proper service manual for specific information, settings and torque specifications.

Key Y = Yes, Acceptable N = No, Remove from Service R = Repaired 0 = Not Applicable

QUARTERLY - Inspect only those marked "Q" **ANNUAL** - Inspect all items

	Q/A	Y/N/O	R		Q/A	Y/N/O	R
DECALS:				BASE:			
Legible - undamaged/readable	A			Fasteners tight	Q		
Capacity decal correct for model	A			Cover panels, No Damage, Secure	Q		
PLATFORM:				Welds, no signs of failure or damage	A		
No damage, all parts present	Q			Hydraulic hoses secure, no leaks	A		
Platform mounting fasteners secure	Q			Check Slew Ring bolt torque (see manual)	A		
Entry gates secure, Self-close properly	Q			Steering king pins, no excessive free play	A		
Manual box secure, Manuals inside	Q			COMPONENT AREA:			
PPSS System operational (if equipped)	Q			Hydraulic; no leaks	Q		
ELEVATING ASSEMBLY:				Hydraulic tank: correct level, breather clean	Q		
Lift Hyd Cylinders: no leaks,	Q			Hoses not damaged, Fittings tight	Q		
Booms do not bleed down with rated cap	Q			Batteries properly filled and cables clean	Q		
Hyd Hoses secure, no visible damage	Q			Hydraulic tank: Oil changed per listed intervals	A		
Beam structures: Straight, no cracks	A			Replace Hydraulic Filters	A		
Welds: secure, no cracks	A			Pressure relief valves, set correctly	A		
Pin Retainers in place, secure	A			OPERATIONAL INSPECTION:			
Transport Lock: operational, lubed	A			All function speeds correct (see Specifications)	Q		
Boom section shimming correct	A			Upper control box, operations correct, smooth	Q		
ELECTRICAL:				Upper controls operate proportionally	Q		
GFCI operates correctly	Q			Emergency Down operates correctly	Q		
No blown fuses	Q			Limit switch(es) Sensors operational	Q		
Comm cable: no damage, secure	Q			Emergency stop switches, stop everything	Q		
Wire harnesses: good cond, secure	A			Parking Brakes operational	Q		
Harness connections: no corrosion	A			Test Platform Overload System operation	Q		
WHEELS:				ENGINE:			
Tires: No damage	Q			Engine serviced per recommendations	Q		
Lug nuts all present, torqued properly	Q			Oil and Coolant Levels correct	Q		
Tires are not leaning in leaning in or out	Q			Fuel lines secure, no leaks	Q		
Drive motors tight, no leaks	A			All shields, guards in place, secure	Q		
King pins lubed	A			Mounting secure	Q		



Lubrication

Operator may perform routine maintenance only. Lubrication listed as Scheduled Maintenance must be performed by a qualified service technician.

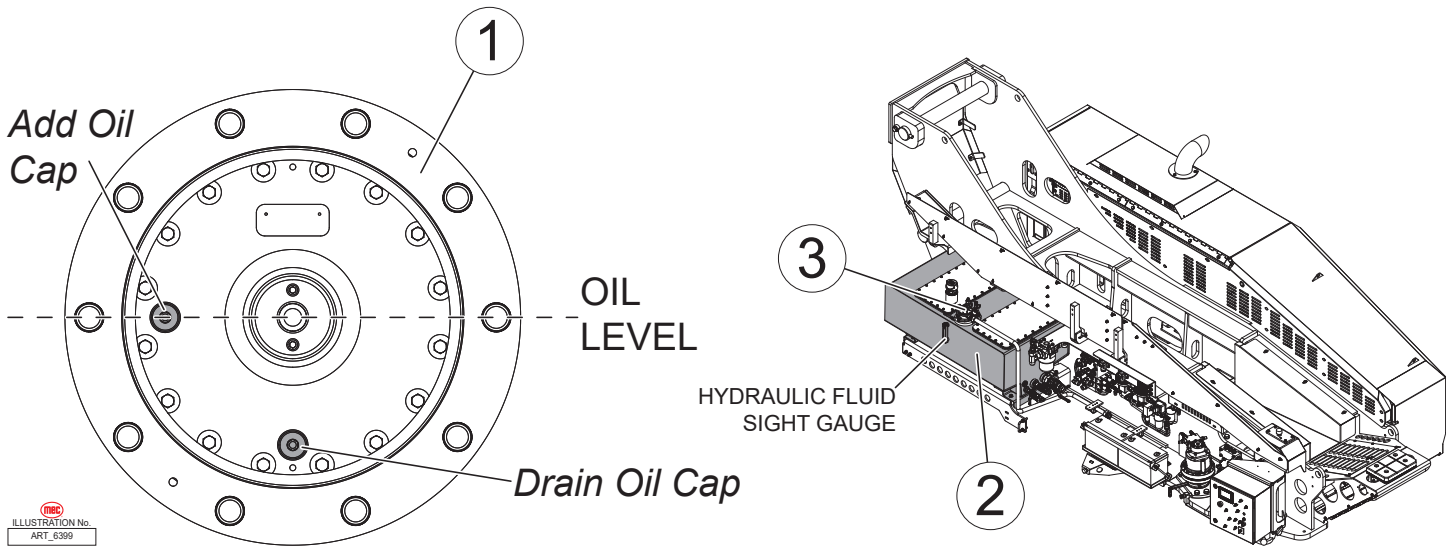

ILLUSTRATION No. ART 6399

Item		Specification	Frequency
1	Hubs	SAE 90 Multipurpose Hypoid Gear Oil API Service Classification GL5	<p>Scheduled Maintenance</p> <ul style="list-style-type: none"> Check every three months or 150 hours, whichever occurs first. Change yearly or every 600 hours, whichever occurs first.
2	Hydraulic Reservoir	<p>Fluid Type Chevron 1000THF Chevron Rando Premium MV</p> <p>Temperature Range >30°F (0°C) < 30°F (0°C)</p> <p>Do not substitute other fluids as pump damage may result.</p> <p>Fill to the middle of the sight gauge with platform in the stowed position and stabilizers retracted.</p>	<p>Routine Maintenance</p> <ul style="list-style-type: none"> Check level daily <p>Scheduled Maintenance</p> <ul style="list-style-type: none"> Change yearly or every 600 hours, whichever occurs first
3	Hydraulic Filter	Filter Element (Located inside Hydraulic Reservoir)	<p>Scheduled Maintenance</p> <p>Normal Conditions</p> <ul style="list-style-type: none"> Change every six months or 300 hours, whichever occurs first <p>Severe Conditions -- very dusty, exceptionally hot or exceptionally cold conditions</p> <ul style="list-style-type: none"> Change every three months or 150 hours, whichever occurs first

Troubleshooting

Should you experience erratic operation or notice any malfunction while operating this machine, discontinue use immediately.



Call for assistance and report the incident to your supervisor, and do not use the machine until it has been checked by a trained, qualified mechanic.

Machine functions will not operate

- Adequate fuel supply?
- Proper fuel blend (i.e. winter blend in cold weather)?
- Battery properly connected?
- Battery fully charged?
- Circuit Breaker tripped?
- Function toggle switch or the Enable Switch not activated?
- Selector Key Switch in proper position?
- Both Emergency Stop Switches reset?
- Secondary guarding switch in un-actuated position
- Hydraulic fluid level low?
- Obvious fluid leak or damaged component?
- Wires disconnected, broken, or loose?
- LED should be ON.
 - Contact MEC Technical Support.
- Technical Support
- Error code at Onboard Diagnostic Center?
 - Contact MEC Customer Service.

Decals

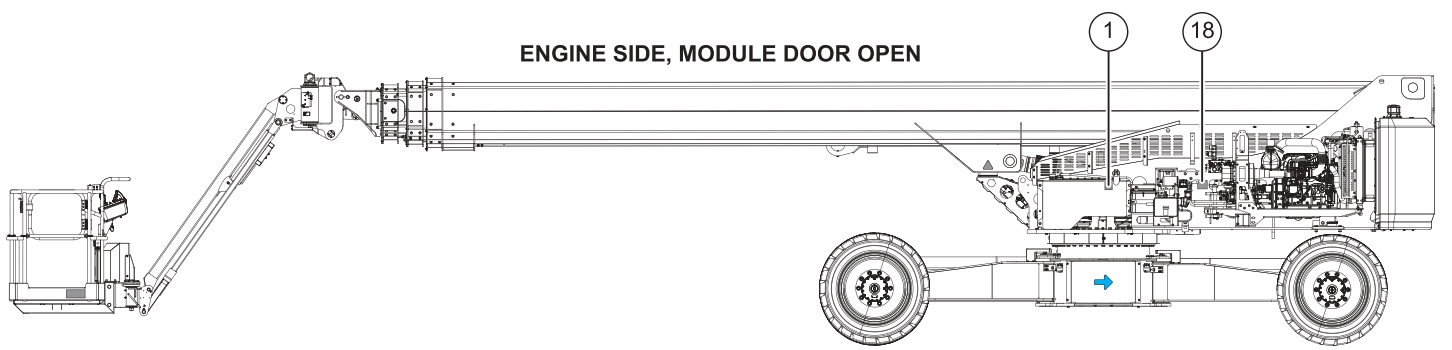
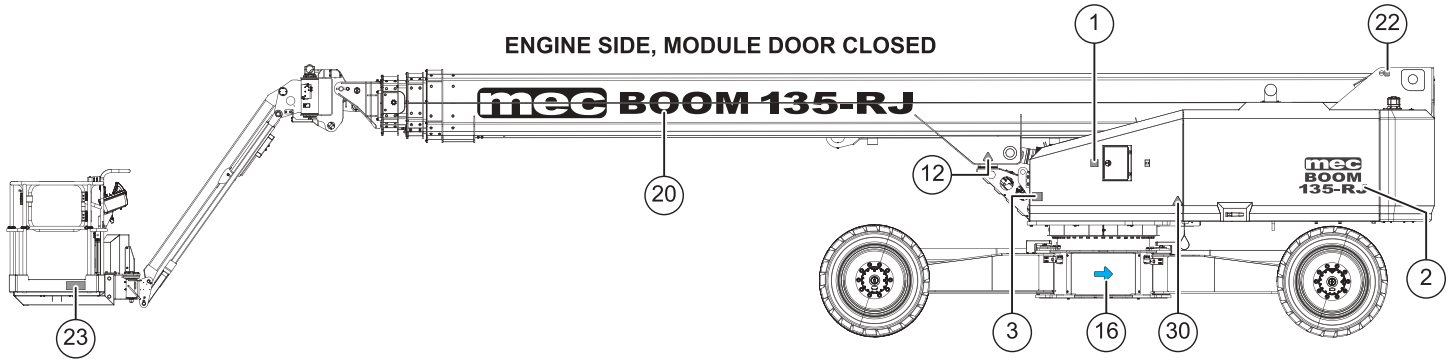
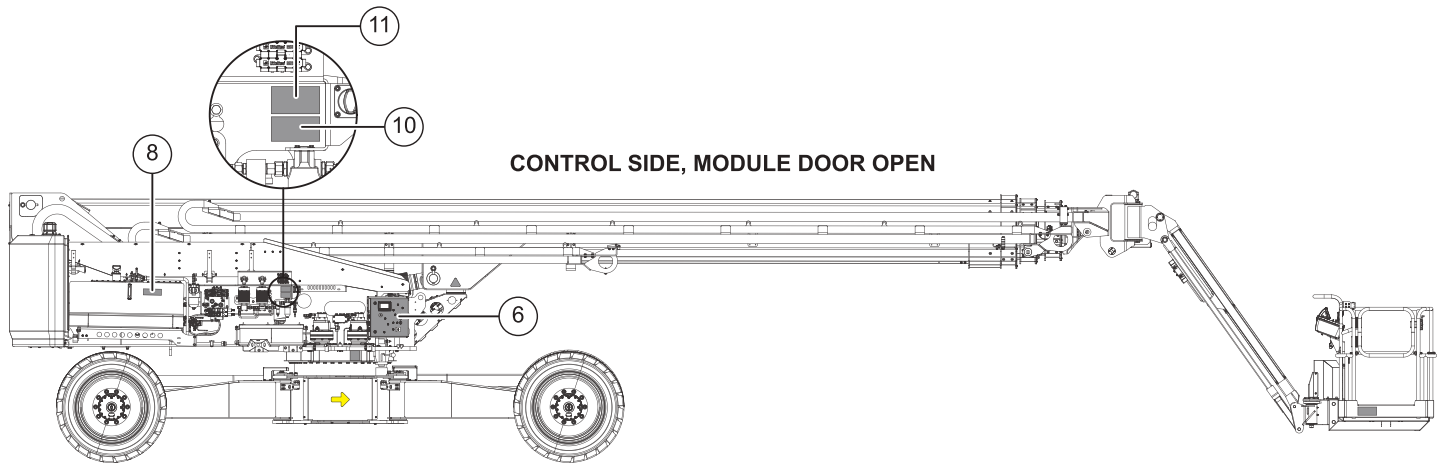
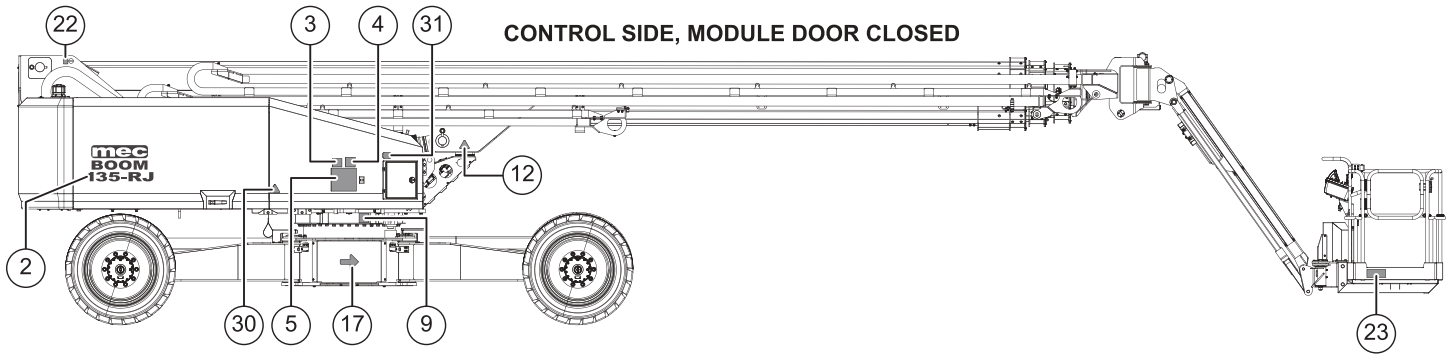



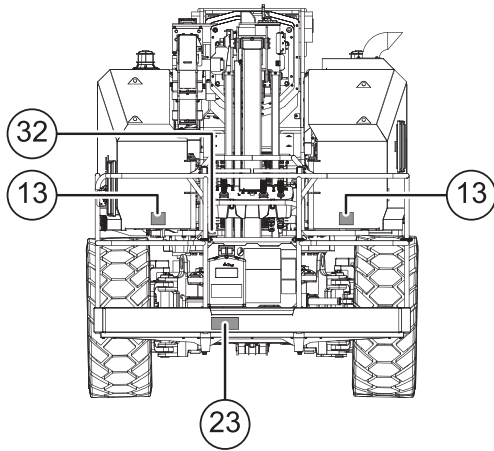



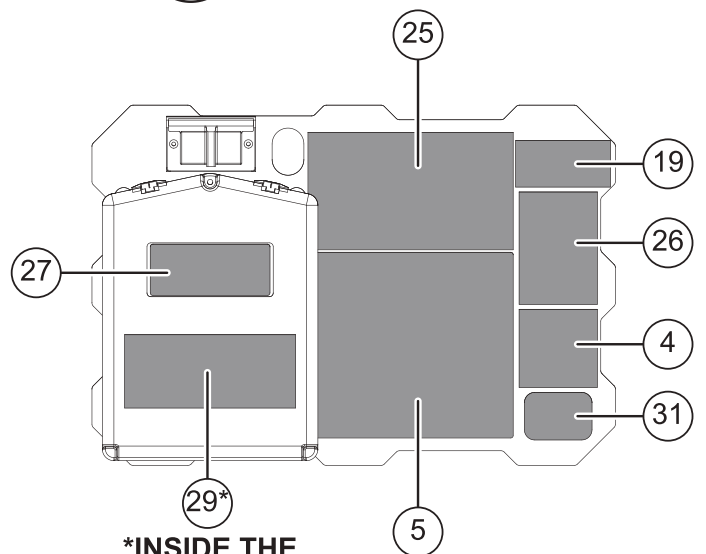
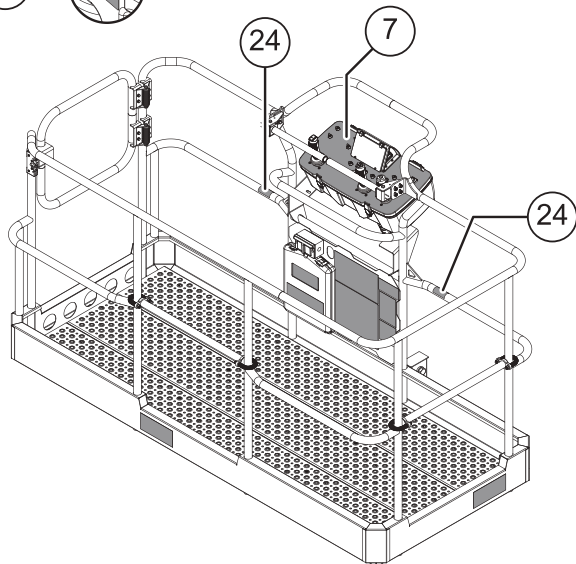
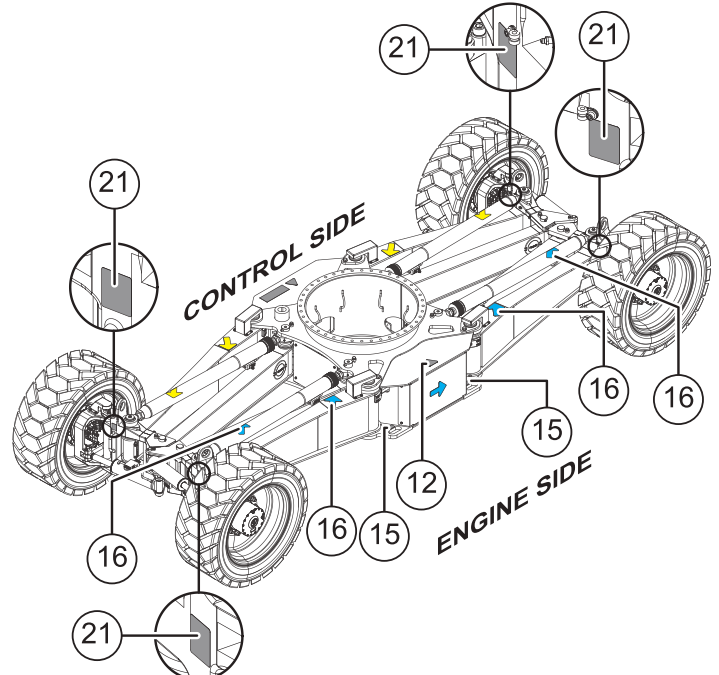
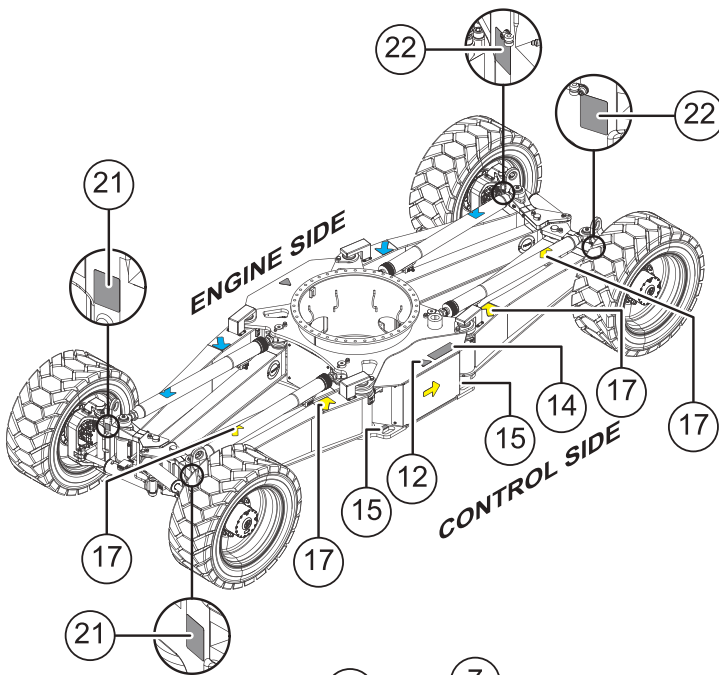
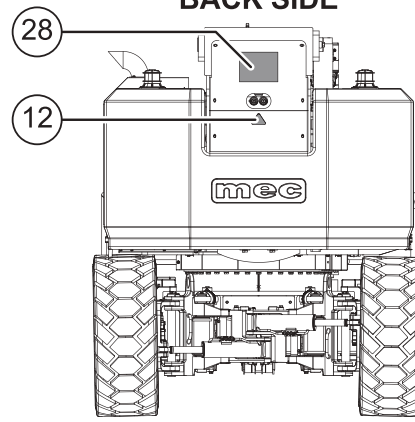



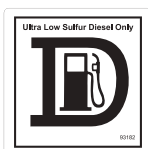



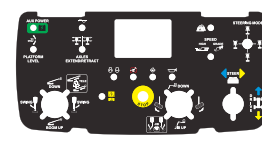
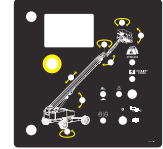
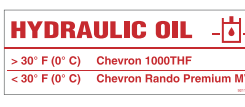
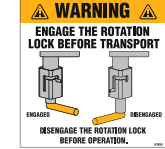







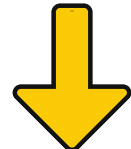

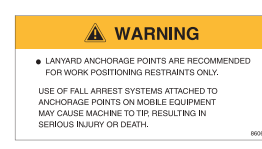

FRONT SIDE

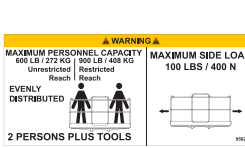

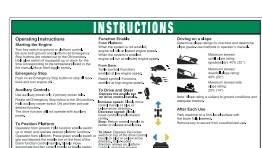
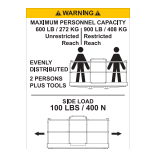
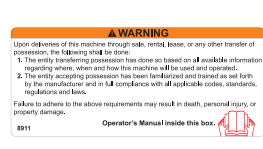
BACK SIDE



***INSIDE THE
MANUAL CASE**

<p>1</p>  <p>93182 Qty. - 2</p>	<p>2</p>  <p>96455 Qty. - 2</p>	<p>3</p>  <p>93801 Qty. - 2</p>	<p>4</p>  <p>93807 Qty. - 2</p>	<p>5</p>  <p>93755 Qty. - 2</p>
<p>6</p>  <p>49356 Qty. - 1</p>	<p>7</p>  <p>49355 Qty. - 1</p>	<p>8</p>  <p>92117 Qty. - 1</p>	<p>9</p>  <p>93855 Qty. - 1</p>	<p>10</p>  <p>90732 Qty. - 1</p>
<p>11</p>  <p>93805 Qty. - 1</p>	<p>12</p>  <p>91850 Qty. - 5</p>	<p>13</p>  <p>93804 Qty. - 2</p>	<p>14</p>  <p>95481 Qty. - 1</p>	<p>15</p>  <p>91973 Qty. - 4</p>
<p>16</p>  <p>96891 Qty. - 5</p>	<p>17</p>  <p>96892 Qty. - 5</p>	<p>18</p>  <p>93806 Qty. - 1</p>	<p>19</p>  <p>8606 Qty. - 1</p>	<p>20</p>  <p>96453 Qty. - 1</p>
<p>21</p>  <p>9311015</p> <p>41635 Qty. - 6</p>	<p>22</p>  <p>9311013</p> <p>41634 Qty. - 4</p>	<p>23</p>  <p>95823 Qty. - 3</p>	<p>24</p>  <p>91970 Qty. - 2</p>	<p>25</p>  <p>93754 Qty. - 1</p>
<p>26</p>  <p>95822 Qty. - 1</p>	<p>27</p>  <p>8911 Qty. - 1</p>	<p>28</p>  <p>90719 Qty. - 1</p>	<p>29</p>  <p>90718 Qty. - 1</p>	<p>30</p>  <p>9910 Qty. - 2</p>
<p>31</p>  <p>96932 Qty. - 2</p>	<p>32</p>  <p>90751 Qty. - 1</p>			

Serial Plate

The serial plate is attached to the machine at the time of manufacture. Important information about the machine is recorded on the serial plate. The Serial Plate is located on the side of the chassis below the Base Controls.

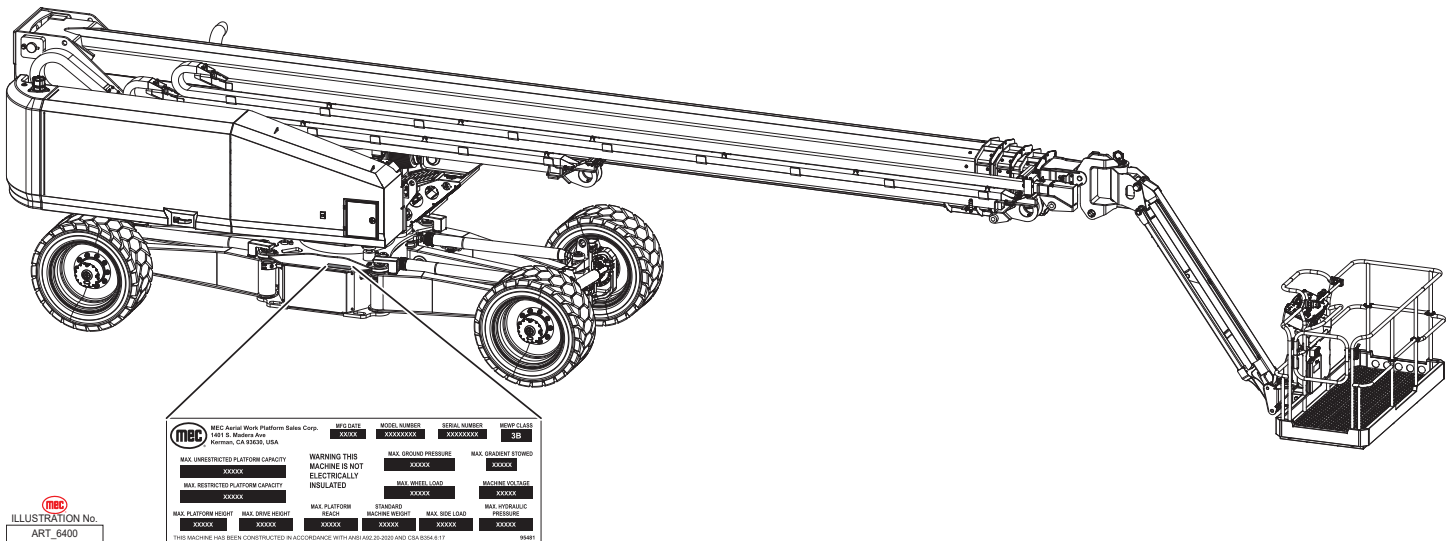

Serial Plate Description

MFG DATE: Month / Year of manufacture.

MODEL NUMBER: Identifies the machine.

SERIAL NUMBER: Identifies a machine with reference to its original owner. Refer to the number when requesting information or ordering parts.

MEWP CLASS: Identifies the type and group.

MAX. PLATFORM UNRESTRICTED CAPACITY: The maximum safe load (material, persons + equipment) which can be correctly placed on the platform within any range of motion.

MAX. PLATFORM RESTRICTED CAPACITY: On optionally equipped machines, the maximum safe load (material, persons + equipment) which can be correctly placed on the platform when used within a restricted range of motion.

MAX. HYDRAULIC SYSTEM PRESSURE: The maximum pressure generated by the machine's hydraulic system.

MAX. WHEEL LOAD: The maximum safe weight applied to each wheel. Calculated with all available options installed. $Fw = 30\% (Wm + Wc + Wopt)$

MACHINE VOLTAGE: The electrical voltage at which the machine operates.

MAX. PLATFORM HEIGHT: The maximum attainable height measured from level ground surface to platform floor.

MAX. WIND SPEED: The maximum allowable wind speed.

MAX. CHASSIS INCLINATION: The maximum allowable chassis inclination.

STANDARD MACHINE WEIGHT: The weight of the machine with no options.

MAX. GROUND PRESSURE: The amount of pressure exerted on the surface at each wheel. Calculated with all available options installed. $Pmax = 30\% (Wm + Wc + Wopt) / \text{Contact Area}$

MAX. SIDE LOAD: The maximum force that can be exerted laterally.

Transport and Lifting Instructions

Safety Information

This section is provided for reference and does not supersede any government or company policy regarding the loading, transport or lifting of MEC machinery.

Truck drivers are responsible for loading and securing machines, and should be properly trained and authorized to operate MEC machinery. Drivers are also responsible for selecting the correct and appropriate trailer according to government regulations and company policy. Drivers must ensure that the vehicle and chains are strong enough to hold the weight of the machine (see the serial number plate for machine weight).



While loading and unloading, the transport vehicle must be parked on a level surface and secured to prevent rolling.

Free-wheel configuration for Winching or Towing

RUNAWAY HAZARD!



After releasing the brakes there is nothing to stop machine travel. Machine will roll freely on slopes.

ALWAYS chock the wheels before manually releasing the brakes.

The machine can be winched or towed short distances at speeds not to exceed 6.2mph (10km/h). If necessary, to transport the vehicle over longer distances and at greater speeds, use a suitable vehicle for transport.

Before towing the vehicle, retract and lower the main boom completely and remove the load from the platform.

Do not use chains for towing the machine. Use steel cables with rings at the ends, or a special rigid tow bar. Make sure the cable is in good condition. Make sure the cable has a nominal carrying capacity 1.5 times the weight of the vehicle to be towed. See serial number plate for machine weight.

Connect one end of the cable to the two front eyelets on the towing vehicle. Connect the other end of the cable to the two front eyelets of the boom. **DO NOT ATTACH ANYTHING TO THE PLATFORM!**

Remove any slack from the cables to prevent movement once the brakes are released. See page 49 for instructions on how to release the brakes.

Brake Release Procedure

Disengage Brakes before Towing or Winching

- Chock the wheels.
- Remove the Torque Engage Cap and reinstall with the bump facing inward on all four (4) hubs.

Engage Brakes before Driving

- Remove the Torque Engage Cap and reinstall with the bump facing outward on all four (4) hubs.

Remove the hoses from the port A and B of the driven pump and then connect two ends of the hoses removed together after completing the brake release procedure.

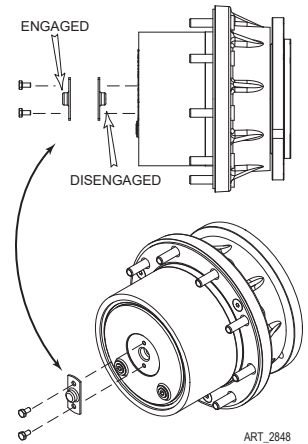

Make sure to reapply the brakes before performing any operation! To reapply the brakes, follow the instructions in reverse!



MAKE SURE THE CABLE HAS A NOMINAL CARRYING CAPACITY 1.5 TIMES THE WEIGHT OF THE VEHICLE TO BE TOWED! SEE SERIAL NUMBER PLATE FOR MACHINE WEIGHT!

Have an operator operate on the machine to be towed to control the moving and steering. An observer must stand in a safe position to monitor operations. The observer must not stand on the vehicle being towed.

Tighten the tow cable slowly. Avoid sudden movements to avoid overload on the cable. Keep the angle between the machine and the towing cable minimum. **It must not exceed 30°!**

Driving or Winching onto or off of a Transport Vehicle

Before loading the machine, orient the turntable so that the platform is over the non-steering wheels so that the Rotation Lock may be engaged later in the loading process.

ONLY properly trained and qualified operators shall load and unload this machine.

Read and understand all safety, control, and operating information found on the machine and in this manual before operating the machine.



Whether winching or driving the machine on to a truck or trailer, always check the area for dangerous situations before moving the machine.

If driving the machine, always use a second person acting as a spotter to make sure the person loading the machine avoids dangerous situations.

Driving

- Turn the Base Key Switch to PLATFORM. Check that the Emergency Stop Switch is reset by pulling it.
- Enter the platform and reset the Platform Emergency Stop Switch.
- Test platform control functions.
- Raise the jib slightly for platform ground clearance.
- Carefully drive the machine off or on to the transport vehicle.
- Make sure you can see the second person giving guidance.

Note: The brakes are automatically released for driving and will automatically apply when the control handle is returned to neutral which causes the machine to stop.

Winching

- Chock the wheels, then disengage brakes (see Brake Release Procedure on page 49).
- Carefully operate the winch to lower the machine down the ramp or pull the machine up the ramp.
- Chock the wheels and engage the brakes before disengaging the winch.

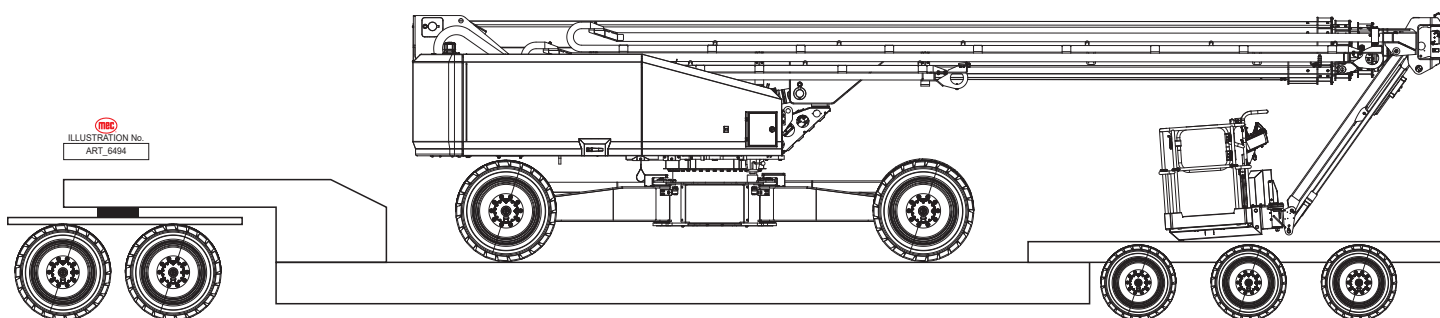

Securing to Truck or Trailer for Transport

- Use a drop bed low loader trailer for transporting the machine.
- Turn the key Selector Key Switch to OFF and remove the key before transport.
- Turn the Battery Disconnect Switch to OFF before transport.
- Inspect the entire machine for loose or unsecured items.
- Secure the chassis.
- Engage the Rotation Lock.
- Secure the platform.

Securing the Chassis

Make sure each of your chains is rated to hold the machine's weight (see serial number plate or Specifications). Use at least 4 chains.

Do not attach chain hooks directly to the machine. Loop the chain through the tie-down point and connect the chain hook to the chain.

Be sure chains are arranged so that they do not damage the machine.

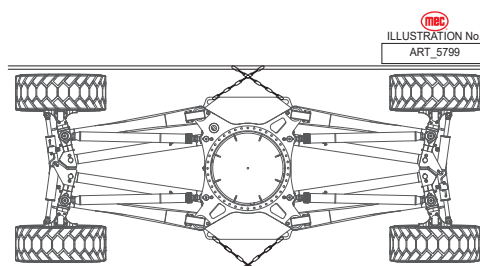

Engaging the Rotation Lock

Before transport, rotate the turntable so that the locking hole aligns with the Rotation Lock located on the chassis. The lock holes are located on the bottom of the Controls Module.

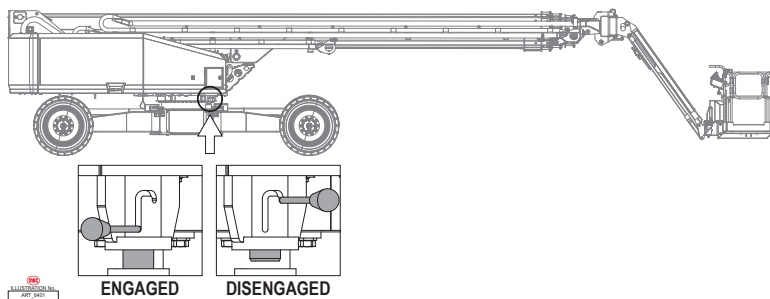

Lift the Rotation Lock using the attached pin, then rotate to the right and lower it into the shallow depression to engage. (See illustration.) Disengage the Rotation Lock before operation.

Securing the Platform

With the boom completely stowed and the jib rotated to be tucked under the main boom. Raise the jib slightly, then use the Platform Level function to lower the platform until the front of the platform touches the trailer surface.

Route the tie-down strap as shown through the width of the platform, over the toe boards of both side entry points. Tighten securely but do not over-tighten.

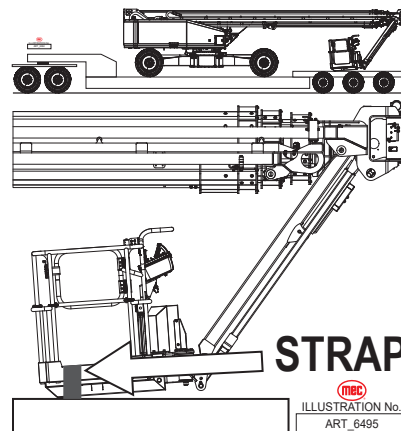

Lifting

Only qualified riggers should rig and lift this machine.



Ensure that the crane capacity, loading surfaces, chains, straps and slings are sufficient to withstand the machine weight. Check the serial plate for the machine weight!

Ensure that the platform is unloaded and that all material and tools have been removed.

Make sure to fully retract in the boom axes and to engage the Rotation Lock before lifting the machine! Carefully move electrical harness or hydraulic lines away from lifting hardware to prevent damage to the electrical and hydraulic system.

Adjust the lifting devices in such a way as to keep the machine level and without causing damage to it.

X-Axis	Y-Axis
36.8in (937mm)	97in (2465mm)

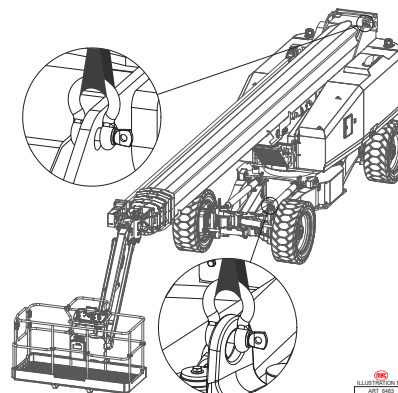
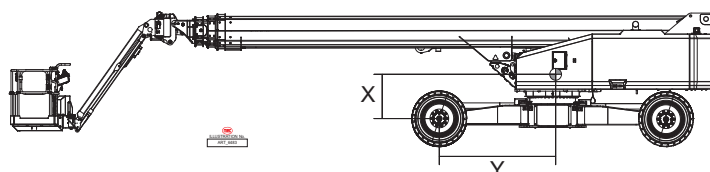

Notes

Notes

Notes



MEC Parts Order Form

Phone: 559-842-1523

Fax: 559-400-6723

Email: Parts@mecawp.com

Please Fill Out Completely:

Date: _____
Account: _____
Bill to: _____

Ordered By: _____
Your Fax No.: _____
Ship to: _____

Purchase Order Number _____

Ship VIA _____

*** All orders MUST have a Purchase Order Number*

***Fed Ex shipments require Fed Ex account number*

Part Number	Description	Quantity	Price

All back-ordered parts will be shipped when available via the same ship method as original order unless noted below:

- Ship complete order only - No Backorders
- Ship all available parts and contact customer on disposition of back-ordered parts
- Other (Please specify)

Signature _____



Limited Owner Warranty

MEC Aerial Platform Sales Corp. warrants its equipment to the original purchaser against defects in material and/or workmanship under normal use and service for one (1) year from date of registered sale or date the unit left the factory if not registered. MEC Aerial Platform Sales Corp. further warrants the structural weldments of the main frame and scissor arms to be free from defects in material or workmanship for five (5) years from date of registered sale or date unit left the factory if not registered. Excluded from such warranty is the battery(s) which carries a ninety (90) day warranty from described purchase date. Warranty claims within such warranty period shall be limited to repair or replacement, MEC Aerial Platform Sales Corp's option, of the defective part in question and labor to perform the necessary repair or replacement based on MEC Aerial Platform Sales Corp's then current flat rate, provided the defective part in question is shipped prepaid to MEC Aerial Platform Sales Corp. and is found upon inspection by MEC Aerial Platform Sales Corp. to be defective in material and/or workmanship. MEC Aerial Platform Sales Corp. shall not be liable for any consequential, incidental or contingent damages whatsoever. Use of other than factory authorized parts; misuse, improper maintenance, or modification of the equipment voids this warranty. The foregoing warranty is exclusive and in lieu of all other warranties, express or implied. All such other warranties, including implied warranties of merchantability and of fitness for a particular purpose, are hereby excluded. No Dealer, Sales Representative, or other person purporting to act on behalf of MEC Aerial Platform Sales Corp. is authorized to alter the terms of this warranty, or in any manner assume on behalf of MEC Aerial Platform Sales Corp. any liability or obligation which exceeds MEC Aerial Platform Sales Corp's obligations under this warranty.



MEC Aerial Work Platforms

1401 S. Madera Avenue, Kerman, CA 93630 USA

Toll Free: 1-877-632-5438

Phone: 1-559-842-1500

Fax: 1-559-842-1520

info@MECawp.com

www.MECawp.com