



Service & Parts Manual

135-RJ

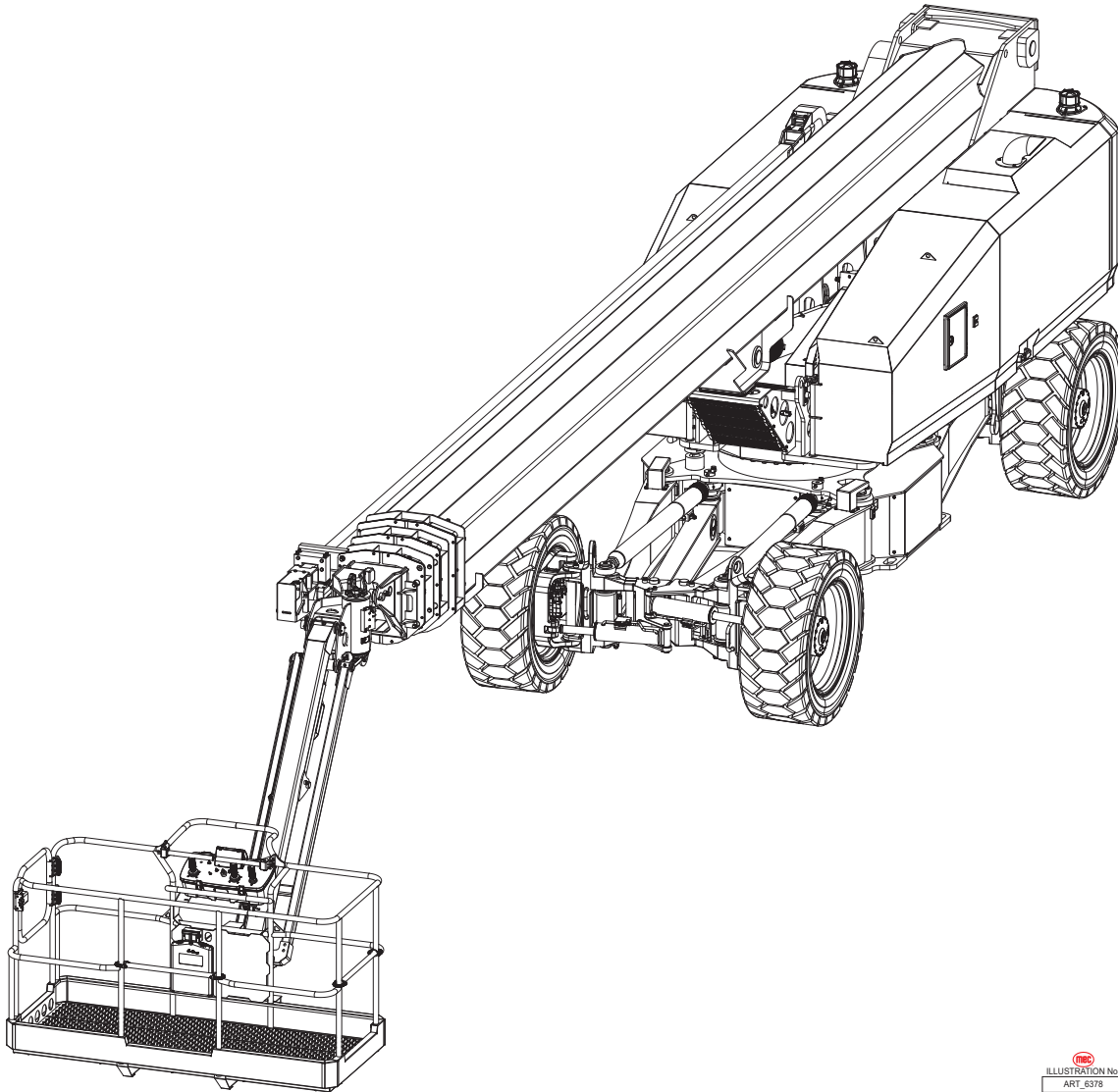

ILLUSTRATION No.
ART_8378

Meets requirements of ANSI A92.20-2020 and CSA B354.6-2019.
Serial Number Range 15100000 - Up

Part # 96909
March 2025

Revision History

Date	Reason for Update
March 2025	New Release



MEC Aerial Work Platforms

1401 S. Madera Avenue, Kerman, CA 93630 USA
Toll Free: 1-877-632-5438
Phone: 1-559-842-1500
Fax: 1-559-842-1520
info@MECawp.com
www.MECawp.com

Table of Contents

Chapter 1 - Service	1
<i>Service Introduction</i>	1
Section 1 - MEC Operator Policy	2
<i>MEC Operator Policy</i>	2
Section 2 - Safety Symbols & General Safety Tips	3
<i>Safety Symbols & General Safety Tips</i>	3
Section 3 - Torque Specifications	4
<i>Bolt Torque Specification - American Standard</i>	4
<i>Bolt Torque Specification - Metric Standard</i>	5
<i>Hydraulic Components Torque Table</i>	6
Section 4 - Specifications	7
<i>Specifications</i>	7
Section 5 - Machine Systems	8
<i>Machine Systems</i>	8
Section 6 - Machine Components	9
<i>Component Locations</i>	9
Section 7 - Emergency Systems and Procedures	10
<i>Emergency Systems and Procedures</i>	10
<i>Auxiliary Power System & Test</i>	11
Section 8 - Transporting and Lifting Instructions	13
<i>Transport and Lifting Instructions</i>	13
Section 9 - Maintenance	17
<i>Maintenance</i>	17
<i>Maintenance Inspection Report</i>	18
<i>Daily Maintenance</i>	19
<i>Biweekly Maintenance</i>	22
<i>Quarterly Maintenance</i>	25
<i>Semi-annual Maintenance</i>	27
<i>Yearly Maintenance</i>	30
<i>1,500 Hour Maintenance</i>	34
<i>Two Year Maintenance</i>	35
<i>Seven Year Maintenance</i>	37
Section 10 - Schematics	38
<i>Hydraulic Schematic</i>	38
<i>Electrical Schematic, Part 1</i>	39
<i>Electrical Schematic, Part 2</i>	40
<i>Electrical Schematic, Part 3</i>	41

<i>Electrical Schematic, Part 4</i>	42
<i>Electrical Schematic, Part 5</i>	43
Chapter 2 - Parts	45
<i>Parts Introduction</i>	45
Section 11 - Chassis	46
<i>Left Front and Right Rear Axle Installation</i>	46
<i>Left Front and Right Rear Axle Components</i>	50
<i>Left Front and Right Rear Tire & Wheel Installation</i>	52
<i>Right Front and Left Rear Axle Installation</i>	54
<i>Right Front and Left Rear Axle Components</i>	58
<i>Right Front and Left Rear Tire & Wheel Installation</i>	60
<i>Chassis Components, Part 1</i>	62
<i>Chassis Components, Part 2</i>	64
<i>Steer Manifold Assembly</i>	66
<i>Traction Manifold Assembly</i>	68
<i>Slewing Ring Installation</i>	70
<i>Chassis Components</i>	72
<i>Gearmotor Installation</i>	74
Section 12 - Turntable	76
<i>Rotary Coupling Installation</i>	76
<i>Hydraulic Tank Installation</i>	78
<i>Function Manifold and Filters Installation</i>	80
<i>Relief Valve</i>	82
<i>Function Manifold Assembly</i>	84
<i>Emergency Pumps Installation</i>	86
<i>Batteries Installation</i>	88
<i>Lower Control Box Installation</i>	90
<i>Limit Switches Installation</i>	92
<i>Hydraulic Cooling System Installation</i>	94
<i>Fuel Tank Installation</i>	96
<i>Hydraulic Generator Assembly</i>	98
<i>Generator Manifold Assembly</i>	100
<i>Engine ECU Installation</i>	102
<i>Engine Swing-Out Tray</i>	104
<i>Deutz Engine Assembly</i>	106
<i>Deutz Engine and Pumps Installation</i>	108
<i>Deutz Engine Radiator, Part 1</i>	110
<i>Deutz Engine Radiator, Part 2</i>	112
<i>Deutz Engine Radiator, Part 3</i>	114
<i>Deutz Engine Fuel System, Part 1</i>	116
<i>Deutz Engine Fuel System, Part 2</i>	118
<i>Deutz Engine Air Filter</i>	120
<i>Deutz Engine Exhaust System</i>	122
<i>Turntable Components</i>	124
<i>Counterweight Installation</i>	126
<i>Turntable Covers</i>	128
<i>Housing Covers</i>	130

Grease System	132
Control Hood Installation, Front	134
Control Hood Installation, Rear	136
Engine Hood Installation, Front	138
Engine Hood Installation, Rear	140
Section 13 - Boom	142
Lifting Cylinder and Boom Installation	142
Telescopic Boom	144
Base Boom Sliding Blocks Installation.	146
Second Boom Sliding Blocks Installation Part 1	148
Second Boom Sliding Blocks Installation Part 2	150
Third Boom Sliding Blocks Installation Part 1	152
Third Boom Sliding Blocks Installation Part 2	154
Fourth Boom Sliding Blocks Installation	156
Boom Shield Installation	158
Telescopic Cylinder Installation	160
Telescopic Cylinder Components Part 1	162
Telescopic Cylinder Components Part 2	164
Third Boom Cable Installation	166
Fourth Boom Cable Installation	168
Carrier System Installation.	170
Carrier System Components	172
Roller Assembly Installation Part 1	174
Roller Assembly Installation Part 2	176
Jib Lifting Cylinder Installation	178
Rotating Jib Installation	180
Platform Rotator Installation	184
Rotating Jib Valve Block Installation	186
Jib Valve Block Assembly	188
Section 14 - Platform	190
Platform Installation	190
Entry Gate Assembly	192
Lift Gate Assembly.	194
Secondary Guarding Bar Assembly	196
Section 15 - Cylinder	198
Steer Cylinder Assembly	198
Axle Cylinder Assembly	200
Lifting Cylinder Assembly	202
Telescopic Cylinder Assembly.	204
Jib Leveling Cylinder Assembly	206
Jib Lifting Cylinder Assembly	208
Section 16 - Hydraulic System	210
Drive Circuit	210
Steering and Extend/Retract Circuit	214
Turntable Circuit Part 1	216
Turntable Circuit Part 2	220

<i>Telescopic Boom Circuit</i>	224
<i>Jib Circuit</i>	226
Section 17 - Electrical System	228
<i>Electrical Harness Part 1</i>	228
<i>Electrical Harness Part 2</i>	230
<i>Electrical Harness Part 3</i>	232
<i>Fuse Holder Assembly.</i>	234
<i>Power Distribution Module.</i>	236
<i>Lower Control Box Assembly</i>	238
<i>Upper Control Box Assembly</i>	240
Section 18 - Decals	242
<i>Decals</i>	242

Service Introduction

This Service section is designed to provide you, the customer, with the instructions needed to properly maintain the MEC self-propelled aerial work platform. When used in conjunction with the illustrated Parts section in this manual and the Operator's Manual (provided separately), this manual will assist you in making necessary adjustments and repairs, and identifying and ordering the correct replacement parts.

All parts represented here are manufactured and supplied in accordance with MEC quality standards. We recommend that you use genuine MEC parts to ensure proper operation and reliable performance.

To obtain maximum benefits from your MEC Aerial Work Platforms, always follow the proper operating and maintenance procedures. Only trained authorized personnel should be allowed to operate or service this machine. Service personnel should read and study the Operator's, and the Service and Parts Manuals in order to gain a thorough understanding of the unit prior to making any repairs.

MEC Operator Policy

Note: *The best method to protect yourself and others from injury or death is to use common sense. If you are unsure of any operation, **don't start** until you are satisfied that it is safe to proceed and have discussed the situation with your supervisor.*

Service personnel and machine operators must understand and comply with all warnings and instructional decals on the body of the machine, at the ground controls, and platform control console.



MODIFICATIONS OF THIS MACHINE FROM THE ORIGINAL DESIGN AND SPECIFICATIONS WITHOUT WRITTEN PERMISSION FROM MEC ARE STRICTLY FORBIDDEN. A MODIFICATION MAY COMPROMISE THE SAFETY OF THE MACHINE, SUBJECTING OPERATOR(S) TO SERIOUS INJURY OR DEATH.

MEC's policies and procedures demonstrate our commitment to Quality and our relentless ongoing efforts towards Continuous Improvement, due to which product specifications are subject to change without notice.

Any procedures not found within this manual must be evaluated by the individual to assure oneself that they are "proper and safe."

Your MEC Aerial Work Platform has been designed, built, and tested to provide many years of safe, dependable service. Only trained, authorized personnel should be allowed to operate or service the machine.

MEC, as manufacturer, has no direct control over machine application and operation. Proper safety practices are the responsibility of the user and all operating personnel.

If there is a question on application and/or operation, contact MEC Aerial Work Platforms:



MEC Aerial Work Platforms

1401 S. Madera Avenue, Kerman, CA 93630 USA

Toll Free: 1-877-632-5438

Phone: 1-559-842-1500

Fax: 1-559-842-1520

info@MECawp.com

www.MECawp.com

Safety Symbols & General Safety Tips

MEC manuals and decals use symbols, colors and signal words to help you recognize important safety, operation and maintenance information.



RED and the word **DANGER** – Indicates an imminently hazardous situation which, if not avoided, will result in death or serious injury.



ORANGE and the word **WARNING** – Indicates a potentially hazardous situation which, if not avoided, could result in death or serious injury.



YELLOW with alert symbol and the word **CAUTION** – Indicates a potentially hazardous situation which, if not avoided, may result in minor or moderate injury.



YELLOW without alert symbol and the word **CAUTION** – Indicates a potentially hazardous situation which, if not avoided, may result in property damage.



GREEN and the word **NOTICE** – Indicates operation or maintenance information.

Regular inspection and constant maintenance is the key to efficient economical operation of your aerial work platform. It will help to assure that your equipment will perform satisfactorily with a minimum of service and repair.



The actual operating environment of the machine governs the inspection schedule. Correct lubrication is an essential part of the preventative maintenance to minimize wear on working parts and ensure against premature failure. By maintaining correct lubrication, the possibility of mechanical failure and resulting downtime is reduced to a minimum.

- Never leave hydraulic components or hoses open. They must be protected from contamination (including rain) at all times.
- Never open a hydraulic system when there are contaminants in the air.
- Always clean the surrounding area before opening hydraulic systems.
- Use only recommended lubricants. Improper lubricants or incompatible lubricants may be as harmful as no lubrication.
- Watch for makeshift “fixes” which can jeopardize safety as well as lead to more costly repair.

Bolt Torque Specification - American Standard

Fasteners

Use the following values to apply torque unless a specific torque value is called out for the part being used.

American Standard Cap Screws								
SAE Grade	5				8			
Cap Screw Size (Inches)								
	Torque				Torque			
	Ft-lbs		Nm		Ft-lbs		Nm	
	Min	Max	Min	Max	Min	Max	Min	Max
1/4 - 20	6.25	7.25	8.5	10	8.25	9.5	11	13
1/4 - 28	8	9	11	12	10.5	12	14	16
5/16 - 18	14	15	19	20	18.5	20	25	27
5/16 - 24	17.5	19	12	26	23	25	31	34
3/8 - 16	26	28	35	38	35	37	47.5	50
3/8 - 24	31	34	42	46	41	45	55.5	61
7/16 - 14	41	45	55.5	61	55	60	74.5	81
7/16 - 20	51	55	69	74.5	68	75	92	102
1/2 - 13	65	72	88	97.5	86	96	116	130
1/2 - 20	76	84	103	114	102	112	138	152
9/16 - 12	95	105	129	142	127	140	172	190
9/16 - 18	111	123	150	167	148	164	200	222
5/8 - 11	126	139	171	188	168	185	228	251
5/8 - 18	152	168	206	228	203	224	275	304
3/4 - 10	238	262	322	255	318	350	431	474
3/4 - 16	274	302	371	409	365	402	495	544
7/8 - 9	350	386	474	523	466	515	631	698
7/8 - 14	407	448	551	607	543	597	736	809
1 - 8	537	592	728	802	716	790	970	1070
1 - 14	670	740	908	1003	894	987	1211	1137





Torque values apply to fasteners as received from the supplier, dry or when lubricated with normal engine oil.

If special graphite grease, molydisulphide grease, or other extreme pressure lubricants are used, these torque values do not apply.

Bolt Torque Specification - Metric Standard

Fasteners

Use the following values to apply torque unless a specific torque value is called out for the part being used.

Metric Cap Screws								
Metric Grade	8.8				10.9			
Cap Screw Size (Millimeters)								
	Torque				Torque			
	Ft-lbs		Nm		Ft-lbs		Nm	
	Min	Max	Min	Max	Min	Max	Min	Max
M6 × 1.00	6	8	8	11	9	11	12	15
M8 × 1.25	16	20	21.5	27	23	27	31	36.5
M10 × 1.50	29	35	39	47	42	52	57	70
M12 × 1.75	52	62	70	84	75	91	102	123
M14 × 2.00	85	103	115	139	120	146	163	198
M16 × 2.50	130	158	176	214	176	216	238	293
M18 × 2.50	172	210	233	284	240	294	325	398
M20 × 2.50	247	301	335	408	343	426	465	577
M22 × 2.50	332	404	450	547	472	576	639	780
M24 × 3.00	423	517	573	700	599	732	812	992
M27 × 3.00	637	779	863	1055	898	1098	1217	1488
M30 × 3.00	872	1066	1181	1444	1224	1496	1658	2027

Torque values apply to fasteners as received from the supplier, dry or when lubricated with normal engine oil.

If special graphite grease, molydisulphide grease, or other extreme pressure lubricants are used, these torque values do not apply.

Hydraulic Components Torque Table

Note: Always lubricate threads with clean hydraulic fluid prior to installation.

Use the following values to torque hydraulic components when a specific value is not available. Always check for torque values in the following places before relying on the Hydraulic Components Torque Table.

- Parts drawings and service instructions in this manual.
- Packaging and instruction sheets provided with new parts.
- Instruction manuals provided by the manufacturer of the component being serviced.

SAE Port Series	Cartridge Poppet		Fittings		Hoses	
	Ft-lbs	Nm	Ft-lbs	Nm	In-lbs	Nm
#4	N/A	N/A	N/A	N/A	135 - 145	15 - 16
#6	N/A	N/A	10 - 20	14 - 27	215 - 245	24 - 28
#8	25 - 30	31 - 41	25 - 30	34 - 41	430 - 470	49 - 53
#10	35 - 40	47 - 54	35 - 40	47 - 54	680 - 750	77 - 85
#12	85 - 90	115 - 122	85 - 90	115 - 122	950 - 1050	107 - 119
#16	130 - 140	176 - 190	130 - 140	176 - 190	1300 - 1368	147 - 155

Specifications

Maximum Working Height		141.5 feet	43.15 meters
Maximum Working Radius		82.02 feet	25.0 meters
Maximum Platform Height ¹		135 feet	41.15 meters
Maximum Platform Radius		80.05 feet	24.4 meters
Maximum Drive Height		135 feet	41.15 meters
Overall Length, Stowed Position		39.2 feet	11.96 meters
Overall Width, Stowed Position		7.8 feet	2.4 meters
Overall Width, Axles Deployed		14.7 feet	4.49 meters
Overall Height, Stowed Position		9.2 feet	2.83 meters
Platform Lift Capacity	Unrestricted	600 pounds	272 kilograms
	Restricted	900 pounds	408 kilograms
Maximum Occupants		2 Person	
Platform Details	Width	7.5 feet	2.3 meters
	Depth	3.2 feet	1 meter
	Entry	1 End Swing Gate, 2 Slide Bar Entries	
Gradeability	Stowed, Downhill	45% (24.2°)	
	Stowed, Uphill	45% (24.2°)	
Turntable Rotation		360° Continuous	
Maximum Main Boom Up Angle		77.5°	
Jib Horizontal Range	Working	130°	
	Stowed	220°	
Jib Vertical Range		135°	
Platform Rotation		180° (90° Each Side)	
Tail Swing, Axles Deployed		3.5 feet	1.07 meters
Tail Swing, Axles Retracted		7.4 feet	2.28 meters
Wheel Base, Axles Deployed		14.6 feet	4.48 meters
Wheel Base, Axles Retracted		15.7 feet	4.8 meters
Machine Weight ² (Unloaded)		44,775 pounds	20,310 kilograms
Maximum Wind Speed		28mph	12.5m/sec (45 km/h)
Ground Clearance		1.3 feet	0.4 meters
Engine		74 HP Deutz TD 2.9-L4	
Fuel Type		Diesel	
Fuel Capacity		39.6 gallons	150 liters
Hydraulic Fluid Capacity		60.7 gallons	230 liters
<p>Meets requirements of ANSI A92.20-2020 and CSA B354.6-2019. Allowable ambient temperature range: -20°F to 120°F (-29°C to 49°C). Consult with MEC for operation outside of this range. ¹ Working Height adds 6 feet (2 meters) to platform height. ² Weight may increase with certain options.</p>			

Machine Systems

Hydraulic System



HYDRAULIC FLUID UNDER PRESSURE CAN PENETRATE AND BURN SKIN, DAMAGE EYES, AND MAY CAUSE SERIOUS INJURY, BLINDNESS, AND EVEN DEATH. CORRECT LEAKS IMMEDIATELY.



Hydraulic fluid leaks under pressure may not always be visible. Check for pin hole leaks with a piece of cardboard, not your hand.

Electrical System

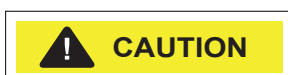

Prevent damage to battery and/or electrical system;

- **Always disconnect the negative battery cable first.**
- **Always connect the positive battery cable first.**

When the negative cable is installed, a spark will occur if contact is made between the positive side of the battery and a metal surface on the machine. This can cause damage to the electrical system, battery explosion, and personal injury.

Total System

ENGINE COOLANT LEVEL MUST BE CHECKED ONLY AFTER ENGINE HAS COOLED. IF RADIATOR CAP IS REMOVED WHILE THE COOLANT IS AT NORMAL OPERATING TEMPERATURE, PRESSURE WITHIN THE COOLANT SYSTEM WILL FORCE HOT LIQUID OUT THROUGH THE FILLER OPENING AND MAY CAUSE SEVERE SCALDING.



FAILURE TO PERFORM PREVENTIVE MAINTENANCE AT RECOMMENDED INTERVALS MAY RESULT IN THE UNIT BEING OPERATED WITH A DEFECT THAT COULD RESULT IN INJURY OR DEATH OF THE OPERATOR.

IMMEDIATELY REPORT TO YOUR SUPERVISOR ANY DEFECT OR MALFUNCTION. ANY DEFECT SHALL BE REPAIRED PRIOR TO CONTINUED USE OF THE AERIAL WORK PLATFORM.

INSPECTION AND MAINTENANCE SHOULD BE PERFORMED BY QUALIFIED PERSONNEL FAMILIAR WITH THE EQUIPMENT.

Component Locations

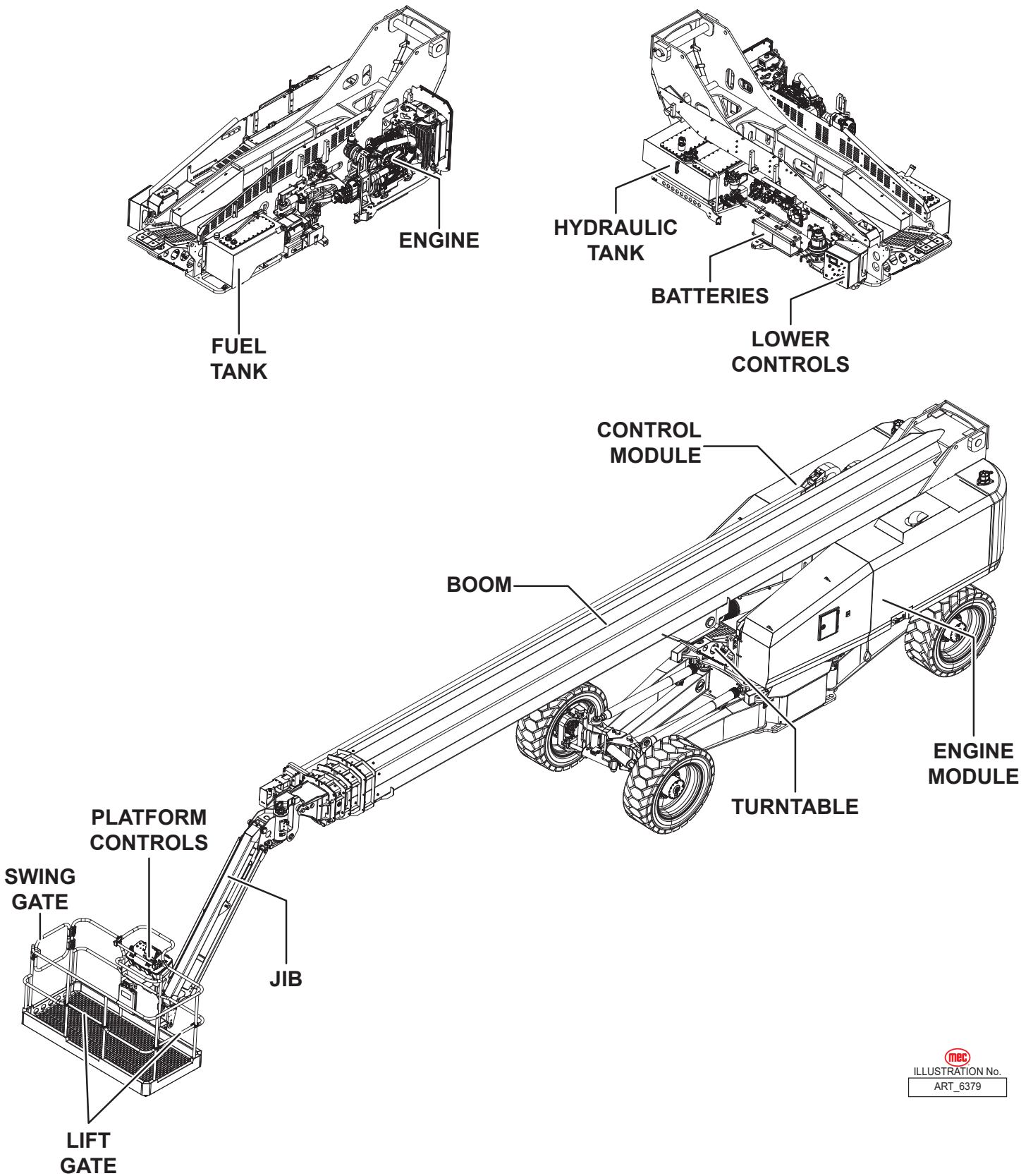



ILLUSTRATION No.
ART_6379

Emergency Systems and Procedures



IF THE CONTROL SYSTEM FAILS WHILE THE PLATFORM IS ELEVATED, HAVE AN EXPERIENCED OPERATOR USE THE EMERGENCY LOWERING PROCEDURE TO SAFELY LOWER THE PLATFORM.

DO NOT ATTEMPT TO CLIMB DOWN ELEVATING ASSEMBLY.

Emergency Stop

The machine is equipped with an Emergency Stop switch on both control panels.

- Press the Emergency Stop switch at any time to stop all machine functions.
- Pull the button to reset it.

Selector Switch set to Platform

- Either switch will stop all machine functions.
- Both switches must be reset or machine will not operate.

Selector Switch is set to Base

- The upper controls are locked out.
- The lower controls switch must be reset or the machine will not operate.
- The machine will operate from the lower controls if the upper controls switch is tripped.



ART_3353

Auxiliary Power System & Test

If primary power fails while the platform is elevated, use the Auxiliary Power System to safely lower the platform.



Do not climb down the boom assembly or exit the platform while elevated.

ALWAYS check over, under and around the machine for personnel, structures and obstructions before activating any control function and continue to watch for hazards while operating the machine.

Platform Controls



Upper Auxiliary Power Switch

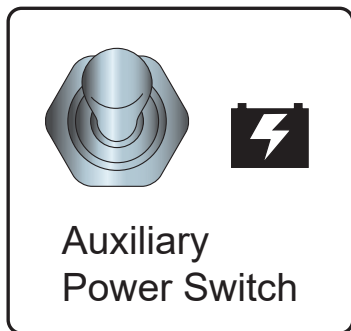

Base Controls

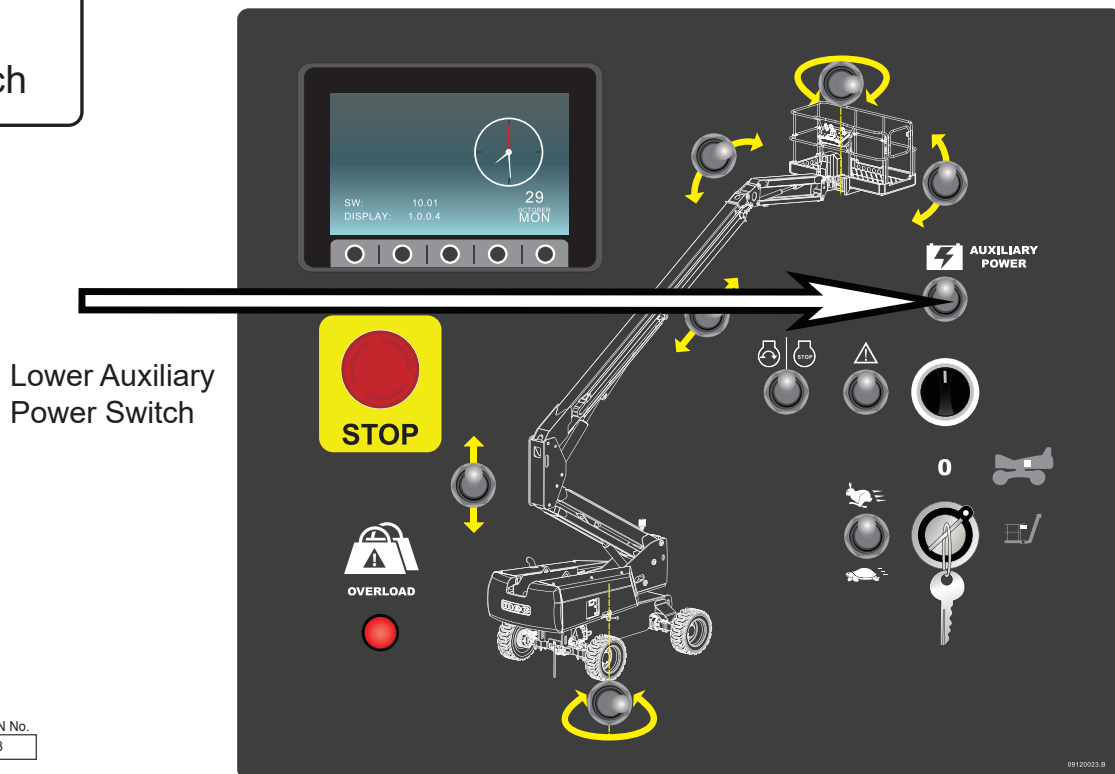

Lower Auxiliary Power Switch

The Auxiliary Power System is used to lower the platform in case of primary power failure. To lower the platform, activate the Auxiliary Power Switch to run the auxiliary hydraulic pump.

This function uses battery power from the auxiliary battery to lower the platform.

- Push and hold the Auxiliary Power Switch, then use the Boom Extend/Retract function to retract the boom.
- Continue to hold the Auxiliary Power Switch, then use the Boom Lift/Lower function to lower the boom.

Note: The Auxiliary Power System is disabled when the engine is running.

Note: The Auxiliary Power Switch serves as an enable switch. It is not necessary to use the primary function enable switch.

Transport and Lifting Instructions

Safety Information

This section is provided for reference and does not supersede any government or company policy regarding the loading, transport or lifting of MEC machinery.

Truck drivers are responsible for loading and securing machines, and should be properly trained and authorized to operate MEC machinery. Drivers are also responsible for selecting the correct and appropriate trailer according to government regulations and company policy. Drivers must ensure that the vehicle and chains are strong enough to hold the weight of the machine (see the serial number plate for machine weight).



While loading and unloading, the transport vehicle must be parked on a level surface and secured to prevent rolling.

Free-wheel configuration for Winching or Towing

RUNAWAY HAZARD!



After releasing the brakes there is nothing to stop machine travel. Machine will roll freely on slopes.

ALWAYS chock the wheels before manually releasing the brakes.

The machine can be winched or towed short distances at speeds not to exceed 6.2mph (10km/h). If necessary, to transport the vehicle over longer distances and at greater speeds, use a suitable vehicle for transport.

Before towing the vehicle, retract and lower the main boom completely and remove the load from the platform.

Do not use chains for towing the machine. Use steel cables with rings at the ends, or a special rigid tow bar. Make sure the cable is in good condition. Make sure the cable has a nominal carrying capacity 1.5 times the weight of the vehicle to be towed. See serial number plate for machine weight.

Connect one end of the cable to the two front eyelets on the towing vehicle. Connect the other end of the cable to the two front eyelets of the boom. **DO NOT ATTACH ANYTHING TO THE PLATFORM!**

Remove any slack from the cables to prevent movement once the brakes are released. See page 14 for instructions on how to release the brakes.

Brake Release Procedure

Disengage Brakes before Towing or Winching

- Chock the wheels.
- Remove the Torque Engage Cap and reinstall with the bump facing inward on all four (4) hubs.

Engage Brakes before Driving

- Remove the Torque Engage Cap and reinstall with the bump facing outward on all four (4) hubs.

Remove the hoses from the port A and B of the driven pump and then connect two ends of the hoses removed together after completing the brake release procedure.

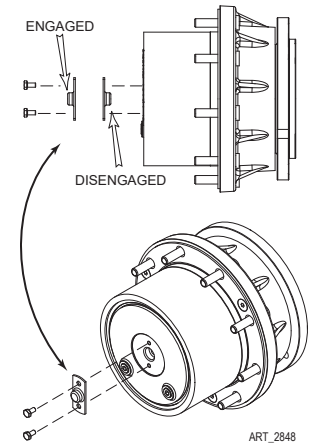

Make sure to reapply the brakes before performing any operation! To reapply the brakes, follow the instructions in reverse!



MAKE SURE THE CABLE HAS A NOMINAL CARRYING CAPACITY 1.5 TIMES THE WEIGHT OF THE VEHICLE TO BE TOWED! SEE SERIAL NUMBER PLATE FOR MACHINE WEIGHT!

Have an operator operate on the machine to be towed to control the moving and steering. An observer must stand in a safe position to monitor operations. The observer must not stand on the vehicle being towed.

Tighten the tow cable slowly. Avoid sudden movements to avoid overload on the cable. Keep the angle between the machine and the towing cable minimum. **It must not exceed 30°!**

Driving or Winching onto or off of a Transport Vehicle

Before loading the machine, orient the turntable so that the platform is over the non-steering wheels so that the Rotation Lock may be engaged later in the loading process.

ONLY properly trained and qualified operators shall load and unload this machine.

Read and understand all safety, control, and operating information found on the machine and in this manual before operating the machine.



Whether winching or driving the machine on to a truck or trailer, always check the area for dangerous situations before moving the machine.

If driving the machine, always use a second person acting as a spotter to make sure the person loading the machine avoids dangerous situations.

Driving

- Turn the Base Key Switch to PLATFORM. Check that the Emergency Stop Switch is reset by pulling it.
- Enter the platform and reset the Platform Emergency Stop Switch.
- Test platform control functions.
- Raise the jib slightly for platform ground clearance.
- Carefully drive the machine off or on to the transport vehicle.
- Make sure you can see the second person giving guidance.

Note: The brakes are automatically released for driving and will automatically apply when the control handle is returned to neutral which causes the machine to stop.

Winching

- Chock the wheels, then disengage brakes (see Brake Release Procedure on page 14).
- Carefully operate the winch to lower the machine down the ramp or pull the machine up the ramp.
- Chock the wheels and engage the brakes before disengaging the winch.

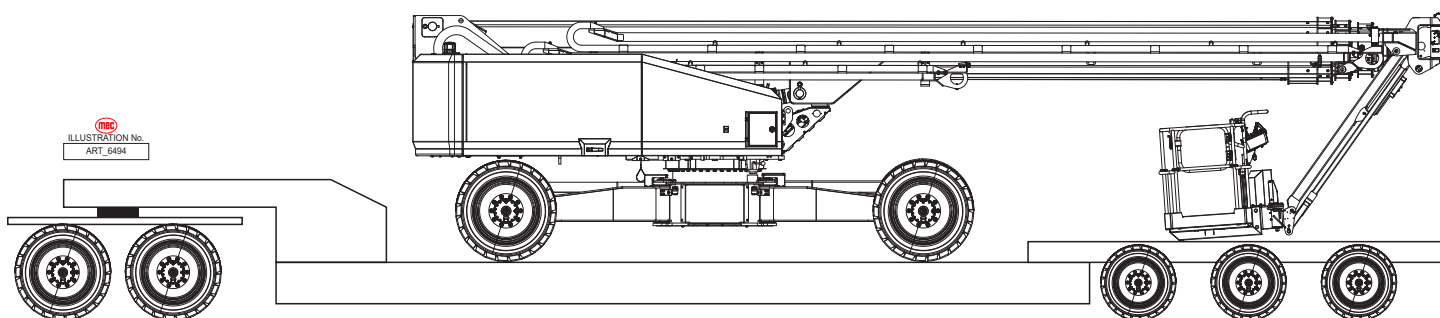

Securing to Truck or Trailer for Transport

- Use a drop bed low loader trailer for transporting the machine.
- Turn the key Selector Key Switch to OFF and remove the key before transport.
- Turn the Battery Disconnect Switch to OFF before transport.
- Inspect the entire machine for loose or unsecured items.
- Secure the chassis.
- Engage the Rotation Lock.
- Secure the platform.

Securing the Chassis

Make sure each of your chains is rated to hold the machine's weight (see serial number plate or Specifications). Use at least 4 chains.

Do not attach chain hooks directly to the machine. Loop the chain through the tie-down point and connect the chain hook to the chain.

Be sure chains are arranged so that they do not damage the machine.

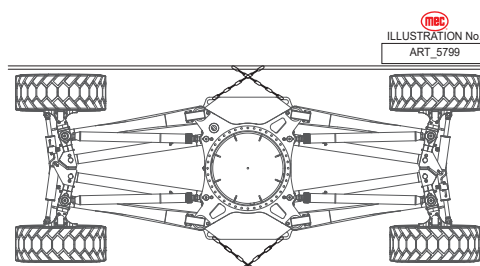

Engaging the Rotation Lock

Before transport, rotate the turntable so that the locking hole aligns with the Rotation Lock located on the chassis. The lock holes are located on the bottom of the Controls Module.

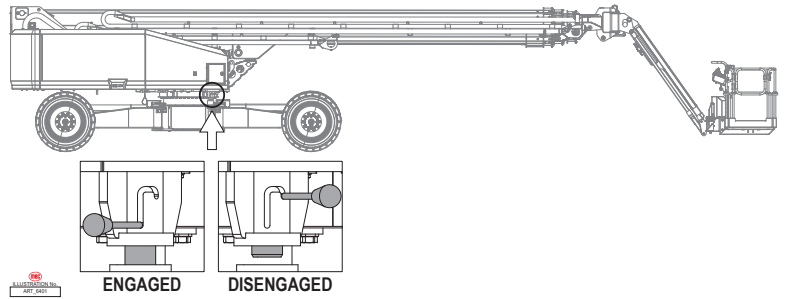

Lift the Rotation Lock using the attached pin, then rotate to the right and lower it into the shallow depression to engage. (See illustration.) Disengage the Rotation Lock before operation.

Securing the Platform

With the boom completely stowed and the jib rotated to be tucked under the main boom. Raise the jib slightly, then use the Platform Level function to lower the platform until the front of the platform touches the trailer surface.

Route the tie-down strap as shown through the width of the platform, over the toe boards of both side entry points. Tighten securely but do not over-tighten.

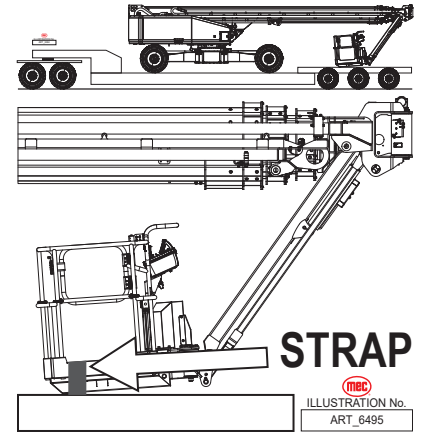

Lifting

Only qualified riggers should rig and lift this machine.



Ensure that the crane capacity, loading surfaces, chains, straps and slings are sufficient to withstand the machine weight. Check the serial plate for the machine weight!

Ensure that the platform is unloaded and that all material and tools have been removed.

Make sure to fully retract in the boom axles and to engage the Rotation Lock before lifting the machine! Carefully move electrical harness or hydraulic lines away from lifting hardware to prevent damage to the electrical and hydraulic system.

Adjust the lifting devices in such a way as to keep the machine level and without causing damage to it.

X-Axis	Y-Axis
36.8in (937mm)	97in (2465mm)

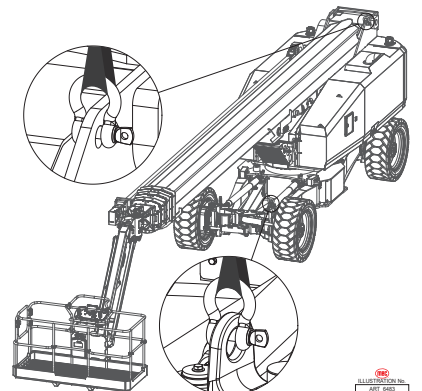
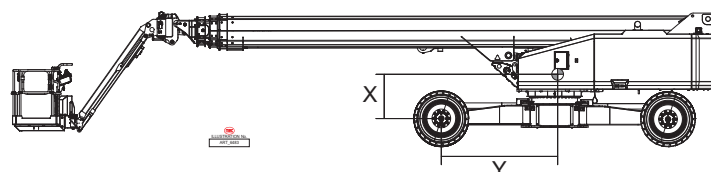

Maintenance

Tag and remove a damaged, malfunctioning or modified machine from service. DO NOT use a damaged, malfunctioning or modified machine.

IMPORTANT: Scheduled maintenance inspection checklists are included in this manual for use only by qualified service technicians. Only qualified service technicians may perform repairs to the machine. After repairs are completed, the operator must perform a Pre-Start Inspection before proceeding to the Functions Test.



Hydraulic fluid under pressure can penetrate and burn skin, damage eyes, and may cause serious injury, blindness, and death. Repair leaks immediately. Fluid leaks under pressure may not always be visible. Check for pin hole leaks with a piece of cardboard, not your hand.

NEVER perform work under the boom assembly with the platform elevated without first supporting the boom assembly.

Failure to perform scheduled maintenance at recommended intervals may result in injury or death. Keep maintenance records current and accurate.



Immediately report any damage, defect, unauthorized modification or malfunction to your supervisor. Any defect must be repaired prior to continued use. DO NOT use a damaged, modified or malfunctioning machine.

DO NOT hang anything over any control handle at any time.

Never leave hydraulic components or hoses open. Plug all hoses and fitting immediately after disassembly to protect the system from outside contamination (including rain).

Never open a hydraulic system when there are contaminants in the air.

Always clean the surrounding area before opening hydraulic systems.



Use only recommended lubricants. Improper lubricants or incompatible lubricants may cause as much damage as no lubrication.

Watch for makeshift “fixes” which can jeopardize safety as well as lead to more costly repair.

Inspection and maintenance should be performed by qualified personnel familiar with the equipment.

Maintenance Inspection Report

135-RJ Boom

Fleet Equipment Number _____ Date _____
 Inspector Name _____ Inspector Co. _____
 Model Number _____ Address _____
 Serial Number _____
 Hour Meter _____ Signature _____
 Machine Owner & address _____

Maintain all service records in accordance with ANSI A92.24-2019

- * Refer to the 135-RJ Service Manual maintenance section for required information before testing.
- * If an inspection receives an "N", remove from service. Once repaired, place an "R" in the box.
- * Refer to the proper service manual for specific information, settings and torque specifications.

Key Y = Yes, Acceptable N = No, Remove from Service R = Repaired 0 = Not Applicable

QUARTERLY - Inspect only those marked "Q" **ANNUAL** - Inspect all items

	Q/A	Y/N/O	R		Q/A	Y/N/O	R
DECALS:				BASE:			
Legible - undamaged/readable	A			Fasteners tight	Q		
Capacity decal correct for model	A			Cover panels, No Damage, Secure	Q		
PLATFORM:				Welds, no signs of failure or damage	A		
No damage, all parts present	Q			Hydraulic hoses secure, no leaks	A		
Platform mounting fasteners secure	Q			Check Slew Ring bolt torque (see manual)	A		
Entry gates secure, Self-close properly	Q			Steering king pins, no excessive free play	A		
Manual box secure, Manuals inside	Q			COMPONENT AREA:			
PPSS System operational (if equipped)	Q			Hydraulic; no leaks	Q		
ELEVATING ASSEMBLY:				Hydraulic tank: correct level, breather clean	Q		
Lift Hyd Cylinders: no leaks,	Q			Hoses not damaged, Fittings tight	Q		
Booms do not bleed down with rated cap	Q			Batteries properly filled and cables clean	Q		
Hyd Hoses secure, no visible damage	Q			Hydraulic tank: Oil changed per listed intervals	A		
Beam structures: Straight, no cracks	A			Replace Hydraulic Filters	A		
Welds: secure, no cracks	A			Pressure relief valves, set correctly	A		
Pin Retainers in place, secure	A			OPERATIONAL INSPECTION:			
Transport Lock: operational, lubed	A			All function speeds correct (see Specifications)	Q		
Boom section shimming correct	A			Upper control box, operations correct, smooth	Q		
ELECTRICAL:				Upper controls operate proportionally	Q		
GFCI operates correctly	Q			Emergency Down operates correctly	Q		
No blown fuses	Q			Limit switch(es) Sensors operational	Q		
Comm cable: no damage, secure	Q			Emergency stop switches, stop everything	Q		
Wire harnesses: good cond, secure	A			Parking Brakes operational	Q		
Harness connections: no corrosion	A			Test Platform Overload System operation	Q		
WHEELS:				ENGINE:			
Tires: No damage	Q			Engine serviced per recommendations	Q		
Lug nuts all present, torqued properly	Q			Oil and Coolant Levels correct	Q		
Tires are not leaning in leaning in or out	Q			Fuel lines secure, no leaks	Q		
Drive motors tight, no leaks	A			All shields, guards in place, secure	Q		
King pins lubed	A			Mounting secure	Q		



Daily Maintenance

The following maintenance should be done daily or every 10 hours of operation, whichever comes first.

1) Inspect the Machine

To ensure the maximum operating life of the machine, thoroughly inspect the machine before starting the machine.

1. Look around and under the machine, checking to make sure that there are none of the following:
 - Loose, rusty, missing or damaged hardware
 - No accumulated dirt or debris
 - Leaking oil, fuel, and other liquids
 - Broken or worn parts
2. Check the state of the machine and hydraulic components.
3. Check the condition of the tires and replace them if necessary.
4. Check the oil, coolant, and other fluid levels and refill if necessary.
5. Remove all accumulated dirt and debris. Carry out all the repairs needed before starting up the machine.
6. Check the state of the battery for corrosion and cleaning. The current battery charge capacity is shown on the diagnostic panel.

2) Check the Engine oil level



Do not check with the engine running!
Do not have sparks, flame, and lighted tobacco nearby!
Danger of burns!

When working on the oil system, make sure to keep the oil system and all nearby areas clean. Make sure to keep the areas thoroughly clean from time to time. Dry any damp areas with air jets. When handling engine oil, make sure to follow all rules and regulations. Make sure to properly dispose of any used engine oil and used filter elements. Do not let the used engine oil spread on the ground.

Run a test cycle after replacing the engine oil. Make sure that the sealing and pressure of the engine oil is correct and at the correct level. An insufficient or excessive amount of engine oil can damage the engine. Make sure that the machine is parked on a flat, level surface and is turned off before checking the engine oil level. Check the engine oil level only while it is warm, 5 minutes after the engine is turned off.

Do not remove the engine oil level rod with the engine running! Danger of burns!

1. Remove the engine oil level rod and wipe it clean with a clean cloth that doesn't leave any lint or fibers. Insert the engine oil rod up to the stop, remove it and read the engine oil level.
2. The oil level must be between the MIN and MAX level. If necessary, add additional engine oil to reach the MAX level. **Do not overfill!**

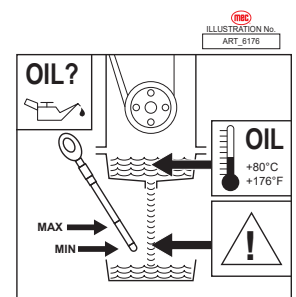

3) Check the Coolant oil level



The coolant is pressurized and at a high temperature when the engine is turned on. When the tank cap is removed, the coolant liquid may flow out violently and cause serious burns. Make sure the engine is cold before working on the cooling system.

1. Make sure that the machine is parked on a flat, level surface.
2. Check the level on the coolant tank placed above the radiator. The fluid level is correct when it is half-way on the inspection window.
3. Open the tank and check the coolant additive concentration ratio using the necessary instrument (e.g. hydrometer, refractometer).
4. If necessary, add more coolant of the correct type until the level indicator shows that the fluid level is in the middle.
5. Put the cap back on and make sure it is tightened properly. Run the engine to bring the coolant up to the required temperature. Switch off the engine and check for any leaks in the hoses.
6. Fluid leaks under pressure may not always be visible. Check for pin hole leaks with a piece of cardboard, not your hand. Repair any leaks found.

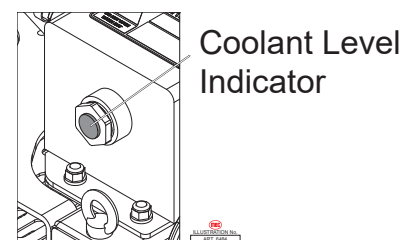

4) Check the Main Boom Sliding Blocks

1. Make sure that the machine is parked on a flat, level surface with an area of sufficient clearance around it for boom functions. Extend the main boom out completely.
2. Check to make sure the main boom movement is smooth. Ensure that there are no abnormal vibrations, unusual noises, and no part of the main boom gets heated due to friction during the movement.
3. Remove the dust guard gaskets at the head of the boom extensions and check to ensure there is a sufficient layer of grease on the sliding surfaces and on the sliding blocks.

5) Auxiliary Power Test

If the machine engine is running, press the red Emergency Stop Switch to stop the engine, and then pull the red Emergency Stop Switch out to reset it. Press up and hold the Auxiliary Power Switch while testing the controls of the boom and platform. After making sure that all the functions work properly, release the switch to stop using auxiliary power.

Note: To avoid draining the batteries, limit the test duration time.

6) Check the Overload Sensor

It's important to make sure that the overload sensor is in good condition before using the machine. The overload sensor in the platform will show how much weight is in the platform on the diagnostic panel. If the weight in the platform does not exceed the maximum rated load, the machine is safe to operate and will function properly.

If the weight exceeds the maximum rated load, the machine will stop operating and the alarm will beep. The diagnostic panel will state that the weight in the platform is over the maximum rated amount and to remove excess weight. Once the excess weight has been removed, the machine will

operate normally.

Check to make sure that none of the bolts are missing, rusty, damaged, or loose and that the overload sensor is undamaged. If the platform is damaged in any way, stop working and make sure to check that the overload sensor is undamaged using the following procedure:

1. Information on the machine's current operating status can be found by pressing down the black button under the Data icon shown on the diagnostic panel.
2. The Load Chart parameter shows the current load in the platform.
3. The Load Chart parameter will show 0lbs (0kg) when the load in the platform is removed completely.
4. The Load Chart parameter will show 900lbs (408kg) at the moment of 900lbs (408kg) being added in the platform.
5. Continue to add weight in the platform, and then the alarm will be activated when the weight is up to 1,124lbs (510kg). If the alarm does not activate, the machine must be repaired.
6. The accuracy of weighting is $\pm 10\%$. If the data exceeds it, stop to calibrate it, referring to the page 32.

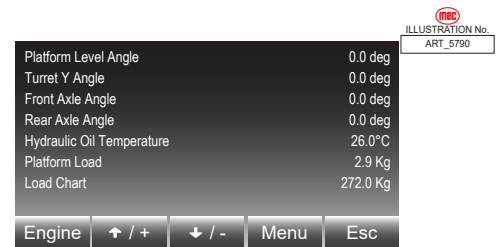

mec		ILLUSTRATION No.
		ART_5790
Platform Level Angle	0.0 deg	
Turret Y Angle	0.0 deg	
Front Axle Angle	0.0 deg	
Rear Axle Angle	0.0 deg	
Hydraulic Oil Temperature	26.0°C	
Platform Load	2.9 Kg	
Load Chart	272.0 Kg	
Engine	↑ / +	↓ / -
	Menu	Esc

7) Check the Counterweight bolts

The counterweight bolts holding the counterweight to the boom turret are vital to balancing the machine.

Check to make sure that the hardware is not missing, damaged, rusty or loose. Replace any defective hardware.

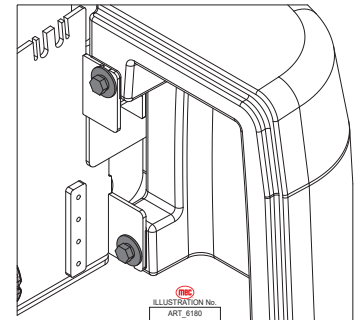

8) Check the Secondary Guarding

1. As a safety feature, there are 2 yellow colored swinging bars positioned above the Platform controls. If one or both bars are pushed forward, all machine functions will stop immediately sounding an alarm.
2. If at any time one or both bars are depressed, evaluate the instance that caused the actuation and proceed accordingly with choice 3 or 4.
3. To reset the system, allow the bars to return to the natural centered position, return all control handles to neutral position and release all enable trigger switches. Normal operation may be resumed.
4. To enable limited operation while one or both bars are depressed, push up and hold the Emergency Platform Bypass switch (see illustration to right). While holding the Bypass switch, select the desired function and operate it in the normal procedure. Certain lift functions such as Riser Boom Up, Main Boom Up, and Telescope out are not available in this bypass mode.
5. If normal operation doesn't resume, please contact Product Support for assistance.

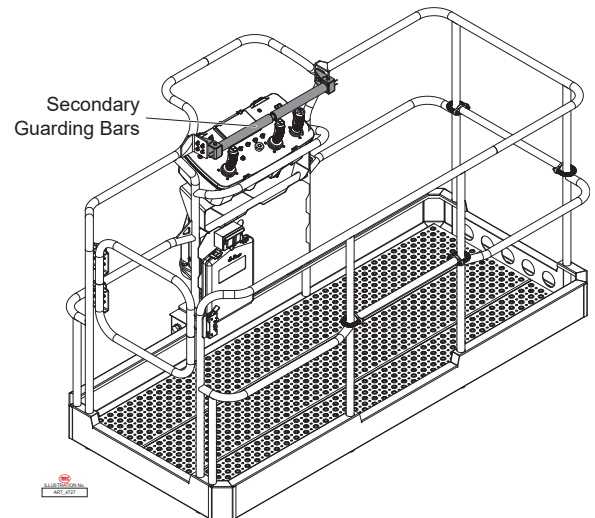

mec
ILLUSTRATION No.
ART_6097



Emergency Platform Bypass Switch

Biweekly Maintenance

The following maintenance should be done every 2 weeks or every 50 hours of operation, whichever comes first.

1) Check the Hydraulic oil level

To make sure that the machine works properly, make sure that the level of the hydraulic oil in the hydraulic tank is sufficient. An incorrect level of oil in the hydraulic system can damage the components.

Daily inspections will make it possible to detect any changes in the oil level which could indicate the presence of faults in the hydraulic system.

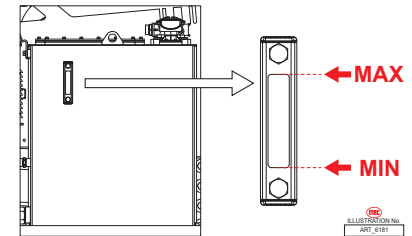

1. Make sure that the machine is parked on a flat, level surface.
2. Make sure the main boom is fully retracted and stowed.
3. Check the oil level indicator on the side of the hydraulic tank.
4. If necessary, add additional hydraulic oil but do not exceed the maximum level!

Note: The hydraulic oil should be filtered with a 20-micron filter.

Result: The hydraulic oil level in the hydraulic system must be between the minimum level and maximum level.

2) Lubricate the Main Boom Sliding Blocks

1. Make sure that the machine is parked on a flat, level surface with an area of sufficient clearance around it for boom functions.
 - Center the turret and fully lower the main boom, then fully extend the telescopic boom.
2. Remove the dust guard gaskets at the head of the boom extensions and clean all the sliding surfaces thoroughly.
3. Using a brush, apply a thin layer of grease on the sliding surfaces on all four sides of the boom. Repeat the operation for each stage of the boom extension.
4. Retract and extend the main boom a number of times to distribute the grease uniformly.
5. Remove any excess grease to prevent dirt build-up and put the dust guard gaskets back on.

3) Drain water from Water-Fuel Separator

Fuel is flammable and can cause severe burns and death.

Do not have sparks, flame, and lighted tobacco nearby while working on the fuel line.

Clean the engine parts and engine compartment to remove all traces of fuel to prevent risk of fire.



1. Make sure that the machine is parked on a flat, level surface.
2. Turn the engine off.
3. Place a suitable container underneath the Water-Fuel separator to catch any liquid that spills.
4. Disconnect the cables.
5. Loosen the drainage screw.
6. Drain the liquid until the pure diesel fuel starts flowing out.
7. Put the drainage cap back on and apply a tightening torque of $1.18 \pm 0.22 \text{ft-lb}$ ($1.6 \pm 0.3 \text{Nm}$).
8. Reconnect the cables.

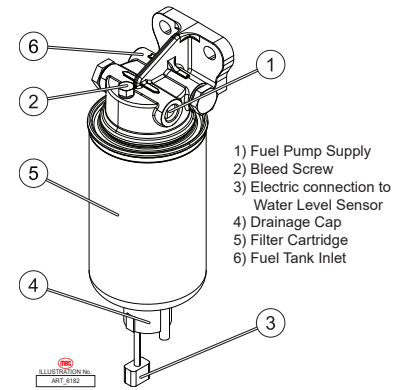

4) Lubricate the Turret Rotation Slew Ring Gear

1. Apply grease manually to the outer teeth with a brush evenly. Remove any excess grease to prevent dirt build-up.
2. After elevating the boom and removing the hoods, keeping turning the turret and apply a moderate amount of grease into the raceway through the grease port fittings with a greasing gun. The Slew Ring grease ports are located under the hydraulic tank.

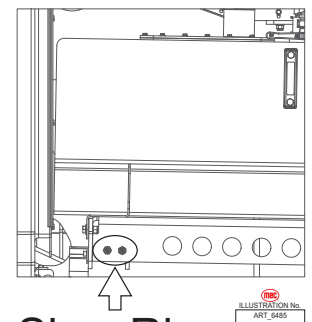

Grease Brand	For Raceway	For Gear Teeth
Shell	Gadus S2 V220 2	MALLEUS OGH
Mobil	Mobilux EP 2S	MOBILTAC 81
Castrol	SPHEEROL EPL 2	MOLLUB-ALLOY 970/2500-1
TotalEnergies	MULTIS EP 2	CERAN AD PLUS
FUCHS	LAGERMEISTER EP 2	CEPLATTYN KG 10 HMF

5) Check the Wheel nut torque

It is extremely important to apply and keep proper torque on the wheel lug nuts. Ensuring that the wheel lug nuts are properly torqued will prevent them from coming loose.

Wheel lug nuts should be torqued after the first 50 hours of operation and after each wheel removal. Use a torque wrench to tighten the nuts. If you do not have a torque wrench, tighten the fasteners with a lug wrench, then immediately have a service garage tighten the lug nuts to the proper torque.

Over-tightening may result in breaking the studs or permanently deforming the mounting stud holes in the wheels. The proper procedure for attaching the wheels is as follows:

1. Set the torque wrench to 331.9ft-lb (450Nm).
2. Tighten wheel lug nuts in the correct sequence as the image shows.

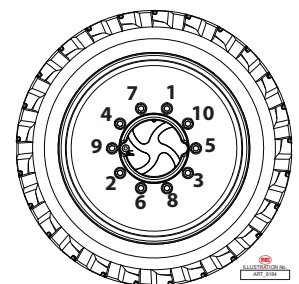

6) Lubricate the Axle Cylinders

1. The axle cylinder grease nipples are covered with plastic coverings. Inject grease in the grease nipples to lubricate the bearing in the cylinder. Remove any excessive grease and put the plastic covering back on.

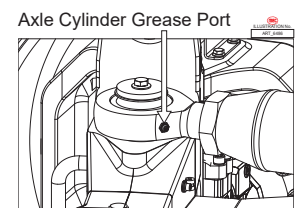

Note: Lubricate during service cycles.

7) Check the Wire Rope tightness

1. All the personnel in the platform must exit the platform and remove any equipment in the platform.
2. Take off the back cover of the main boom and check the sensors as shown in the image.
3. Test the operation of the main boom to check if the movement is smooth and synchronous.
4. Retract the main boom completely and measure the dimensions as shown in the figure.
5. Check rope tension by deflecting the ropes by hand, properly tensioned ropes should have little or no movement.
6. Adjust the tension of the wire rope referring to page 35 if the wire rope is slack.

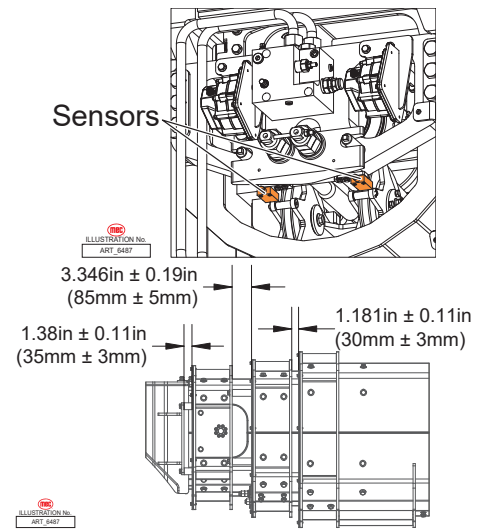

Quarterly Maintenance

The following maintenance should be done every 3 months or every 250 hours of operation, whichever comes first.

1) Check the Transmission Belt



Work on the transmission belt only when the engine has been turned off!
After repairs, make sure all the protection devices have been fitted on and that no tool has been left on the engine.

Checking the Transmission Belt tension

1. To check the tension of the belts, lower the arm of indicator (1) in the tester.
2. Place the guide (3) between two pulleys on the V-belt (2). At this point, the stop must be on the side.
3. Press button (4) in the right hand corner with respect to V-belt (2) uniformly until the spring clicks audibly.
4. Lift the tester gently, without modifying the position of the indicator arm (1).
5. Read the value measured on the intersection point (arrow), scale (5) and indicator arm (1).

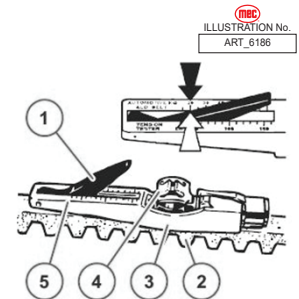

Correct the tension if necessary and repeat the measurement.

Replacing the Transmission Belt

To replace the transmission belt:

1. Loosen the screw and lock nut.
2. Move the generator above the adjuster wrench in direction (B) until the belt slackens.
3. Remove the belts and fit the new ones.
4. Reposition the generator above the adjuster wrench in direction (A) until the belt tension is correct.
5. Check the belt tension:
 - Before tensioning: 479.4±36.8ft-lb (650±50 Nm)
 - Correct tension: 295±36.8ft-lb (400 ± 50 Nm)
6. Tighten the screw and lock nut using the following torque:
 - Screw (1): 22.1ft-lb (30 Nm)
 - Screw (2): 30.9ft-lb (42 Nm)
 - Screw (3): 22.1ft-lb (30 Nm)

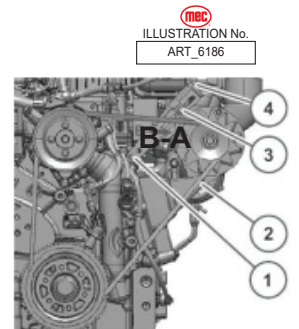

- (1) Screw
- (2) Screw
- (3) Screw
- (4) Adjuster Wrench

2) Check the Wheel Reduction Gear oil

1. Make sure that the machine is parked on a flat, level surface. Keep the work area clear of any debris and unauthorized personnel.
2. Make sure that the gear hub is turned so that one of the oil caps is at the bottom position and the other oil cap is horizontal as the illustration shows.
3. Remove the gear hub oil level cap. The oil level is correct when the oil flows out through the filler hole.
4. If necessary, add additional oil until it reaches the correct level.
5. Put the cap back on and ensure it fits snugly.
6. Repeat this operation for each wheel.

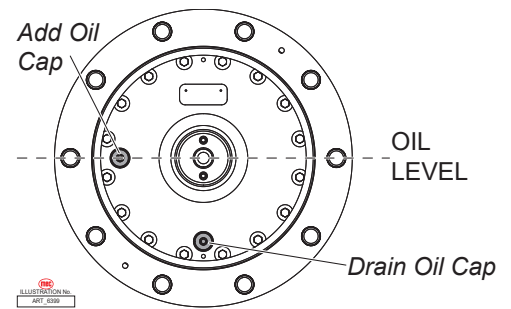

Note: Lubricate during service cycles.

3) Check the Turret Rotation Slew Ring Gear Oil level

1. Open the control hood and if needed, rotate the turret for better access to the reduction gear.
2. Check the hydraulic fluid level through the inspection window. The level is correct when it overflows.
3. If necessary, add additional oil of the correct type up through the port used to add oil.

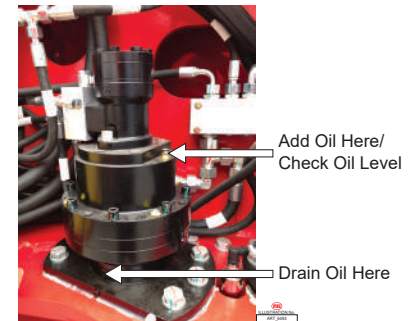

4) Check the condition of the Wire Rope

1. Take off the dust covers and hoods.
2. Inspect ropes for broken wires, particularly valley wire breaks and breaks at the rope end terminations.
3. Inspect ropes for kinks or abuse.
4. Inspect sheaves for condition of bearings and flanges.
5. Replace the rope referring to page 37 if any one of conditions appears.
6. Grease the wire rope.
7. Install back on the dust covers and hoods.

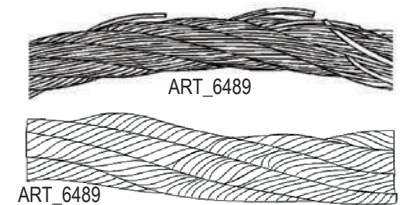

Semi-annual Maintenance

The following maintenance should be done every 6 months or every 500 hours of operation, whichever comes first.

1) Replace the Hydraulic Oil filters

There are six filters used in the hydraulic circuit. Three WU filters used for the suction circuit are installed in the hydraulic tank and these filters are for the drive pump, function pump, and the gear pump. The others are PLFA series filters used in the pressure line of the hydraulic system. The PLFA series filters are set in the outlet of the drive pump, function pump, and the gear pump.

Wu Filters - Hydraulic Tank

1. Open the control hood covering the hydraulic tank.
2. Clean the area around the cover of the hydraulic oil reservoir.
3. Remove the cover from the hydraulic tank and remove the WU filters one by one.
4. Screw in the new corresponding filters.
5. Reapply the filter cover.
6. Check for a drop in the hydraulic oil level by looking at the indicator gauge present on the tank. If required, add additional hydraulic oil of the necessary type to reach the correct level. See page 22 for more details about checking the hydraulic oil level.

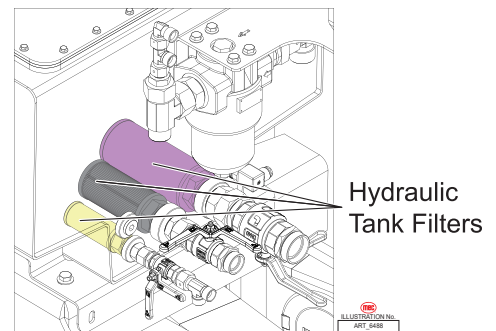

PLFA Filter (Outlet of Function Pump)

1. Clean the area around the oil filter.
2. Remove the filter housing.
3. Pull out the filter element from the filter assembly chamber.
4. Install a new filter element to the filter assembly chamber.
5. Refit the filter housing and tighten it. Clean up any oil that may have spilled during the replacement procedure.

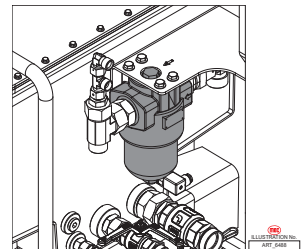

PLFA Filter (Outlet of Drive Pump and Gear Pump)

1. Clean the area around the oil filter.
2. Remove the filter housing.
3. Pull out the filter element from the filter assembly chamber.
4. Install a new filter element to the filter assembly chamber.
5. Refit the filter housing and tighten it. Clean up any oil that may have spilled during the replacement procedure.

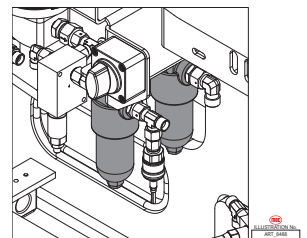

2) Replace the Engine Oil and Engine Oil filter



Do not operate with the engine running!
Do not smoke or have open flames nearby!
Danger of burns!

When working on the oil system, make sure to keep the oil system and all nearby areas clean.

Make sure to keep them thoroughly clean from time to time. Dry any damp areas with air jets. When handling engine oil, make sure to follow all rules and regulations. Make sure to properly dispose of any used engine oil and filter elements. Do not let the used engine oil spread on the ground.

Run a test cycle after replacing the engine oil. Also make sure that the sealing and pressure of the engine oil is correct and at the correct level. An insufficient or excessive amount of engine oil can damage the engine. Make sure that the machine is parked on a flat, level surface and is turned off before checking the engine oil level. Check the engine oil level only while it is warm, 5 minutes after the engine is turned off.

Do not remove the engine oil level rod with the engine running! Danger of burns!

Changing the engine oil

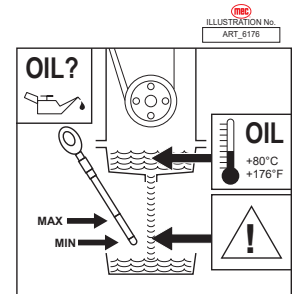

1. Run the engine until the oil temperature reaches more than 176°F (80°C).
2. Make sure that the machine is parked on a flat, level surface and turn the machine off. Keep the work area clear of any debris and unauthorized personnel.
3. Place a suitable container under the drain screw, unscrew the latter and drain out the lubricant oil.
4. After draining, reposition the screw with a new sealing ring and tighten by applying a torque of 40.5ft-lbs (55Nm).
5. Fill with engine oil then operate the engine until the oil temperature reaches more than 176°F (80°C) and check the engine oil level.
6. If necessary, add additional engine oil of the correct type.

Replacing the engine oil cartridge

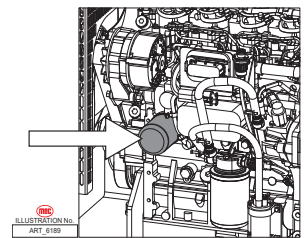

1. Make sure that the machine is parked on a flat, level surface and turn the machine off. Keep the work area clear of any debris and unauthorized personnel.
2. Place a suitable container underneath to catch any liquid that flows out.
3. Loosen the filter by hand, or if necessary then use a tool, and unscrew it.
4. Wipe the surface of the filter-holder with a clean cloth that doesn't leave any lint or fibers.
5. Oil the original DEUTZ filter cartridge seal slightly.
6. Screw the engine oil filter by hand until it is tight.

3) Replace Water-Fuel Separator Filter Element



Fuel is flammable and can cause severe burns and/or death.

Do not smoke or have open flames while working on the fuel line.

Clean the engine parts and engine compartment to remove all traces of fuel to prevent risk of fire.

1. Make sure that the machine is parked on a flat, level surface and turn the machine off. Keep the work area clear of any debris and unauthorized personnel.
2. Block the fuel intake to the engine (if the tank is positioned at the top).
3. Place a suitable container underneath the cartridge to catch any liquid that flows out.
4. Disconnect the cables connected to the Water-Fuel Separator.
5. Loosen the drainage screw and drain out the liquid.
6. Remove the filter element inside.
7. Wipe the surface of the new filter element and the opposite side of the filter head to remove dirt.
8. Slightly dampen the surfaces of the filter cartridge with fuel and screw back on the filter head clockwise with a torque of 12.5-13.2ft-lbs (17-18Nm).
9. Screw the drainage cap back on by applying torque of 1.18±0.2 ft-lbs (1.6±0.3Nm).
10. Reconnect the cables.
11. Open the fuel line and bleed the system.

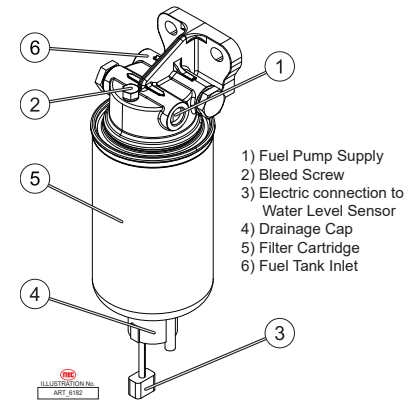

4) Clean the Engine Radiator

To remove dust and debris from the engine radiator, use either compressed air, pressurized water or steam. However, it is recommended to use compressed air.

When using pressurized water, keep the high pressure jet cleaning nozzles at a distance of at least 19.6 inches (50 centimeters) from the engine radiator. Bringing the nozzle too close to the radiator can lead to risk of damaging the radiator.

5) Check the Turret Rotation Slewing Ring Gear bolt torque

Check the bolts on the turret holding the slewing ring gear to see if any are damaged, missing, loose or rusty.

Before checking the torque of the bolts, lift up the main boom. To check the torque for the bolts, use a torque wrench and apply a torque of 442.5ft-lbs (600Nm).

6) Check the Counterweight bolts

The counterweight bolts holding the counterweight to the boom turret are vital to balancing the machine. It is vital to check the torque of the bolts holding the counterweight.

Tighten one by one of the bolts fixing the balance weight with the torque wrench and apply a torque of 442.5ft-lbs (600Nm).

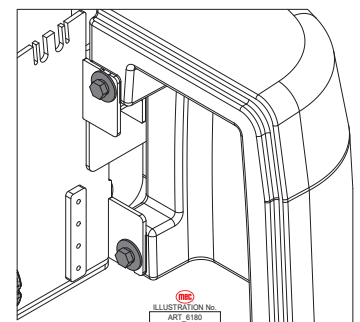

Yearly Maintenance

The following maintenance should be done every year or every 1,000 hours of operation, whichever comes first.

1) Replace the Fuel Filter

1. Make sure that the machine is parked on a flat, level surface and turn the machine off. Keep the work area clear of any debris and unauthorized personnel.
2. Open the Engine Hood.
3. Locate the bolt holding the swing-out tray and carefully remove the bolt. **The tray may swing out after being unbolted!**
4. Move the swing-out tray outward to gain access to the Fuel Filter.
5. Place a suitable container underneath the Fuel Filter to catch any liquid that flows out.
6. Loosen the filter by hand, or if necessary then use a tool, and unscrew it.
7. Collect the fuel that flows out.
8. Wipe the surface of the filter-holder with a clean cloth that does not leave lint.
9. Oil the original DEUTZ filter cartridge seal slightly.
10. Screw the filter by hand until it is tight.
11. Bleed the fuel supply system.

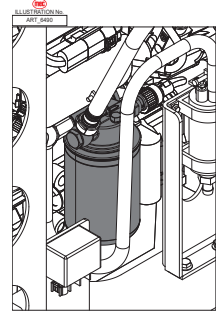
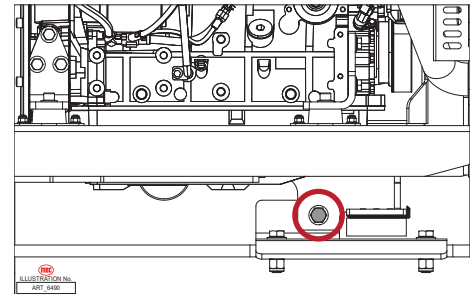

2) Replace the Air Filter element

The efficiency and life of the engine depend greatly on the quality of air taken in. A dirty or damaged air filter can seriously affect the correct working of the engine and increase the possibility of a fault.

Replace the air filter element strictly according to the stated schedule. Do not try to wash dirty filters!

If the machine is expected to be used in environments with a lot of dust or high concentrations of contaminating or polluting agents in the air, halve the time interval between one filter replacement and the next.

Replacing the Air Filter element

1. To access the Air Filter, open the Engine Hood.
2. Release the latches and remove the cover on the front of the filter.
3. Grip the air filter element and remove it from its housing.
4. Thoroughly wipe inside the filter housing with a damp cloth that doesn't leave any fibers. Avoid the use of aggressive solvents or products as these can damage the safety filter or the filter housing.
5. Install a new air filter element. Make sure the filter element is inserted properly in its seat. If installation is difficult, grease the rubber gasket slightly with silicone grease.

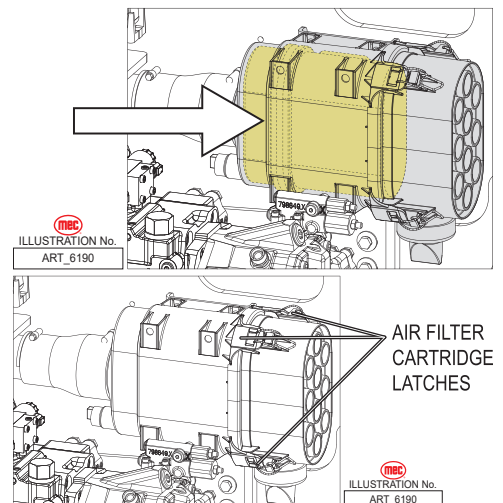

3) Change the Wheel Reduction Gears oil

1. Make sure that the machine is parked on a flat, level surface. Keep the work area clear of any debris and unauthorized personnel.
2. Place a suitable sized container under the reduction gear. Rotate the gear hub so that the oil drain cap is at the very bottom as the illustration shows.
3. Remove the oil drain cap and wait for the oil to drain out completely.
4. Plug the oil drain cap back in place tightly and remove the add oil cap.
5. Pour oil through the opening to the correct level until oil flow out.
6. Plug the cap back in place tightly. Repeat this operation for each wheel.

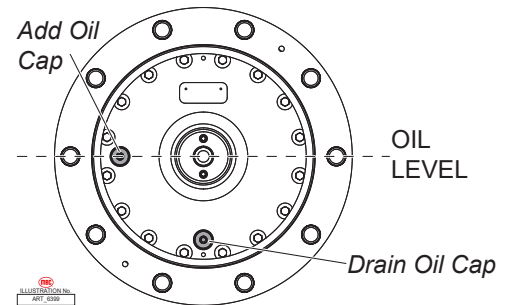

Note: Change the wheel reduction gears oil every 100-250 hours.

4) Adjust the Telescopic Boom sliding blocks

Make sure that the machine is parked on a flat, level surface with an area with sufficient clearance around it for boom functions. Keep the work area clear of any debris and unauthorized personnel.

1. Remove the accessory from the quick-fit coupling. Center the turret and have the main boom fully stowed and lowered.
2. Remove the cover on the rear part of the main boom.
3. Loosen all the bolts on the upper and lower sliding blocks of the first extension stage. If the space between the sliding surface of the block and the sliding surface of the first boom exceeds 0.5mm, some pads will need to be added. Tightens the bolts about with a torque of 73.7ft-lbs (100Nm).
4. Repeat the adjustment operations for the lateral sliding blocks.
5. Move to the front of the main boom, and identify the sliding blocks of the first extension stage.
6. Loosen all the bolt of the upper and lower sliding blocks of the first extension stage. If the space between the sliding surface of the block and the sliding surface of the first boom exceeds 0.5mm, some pads will be need to be added. Tightens the bolts about with a torque of 73.7ft-lbs (100Nm).
7. Repeat the adjustment operations for the lateral sliding blocks.
8. Repeat the operations described above for the sliding blocks of all the extension stages, proceeding in order towards the front part of the boom.
9. Always try to adjust the sliding blocks symmetrically, so that each stage is centered with respect to the adjacent ones.
10. After completing the operations try to extend and retract the boom to check the boom movement is smooth. If the movement of the boom is not smooth, repeat the adjustments.

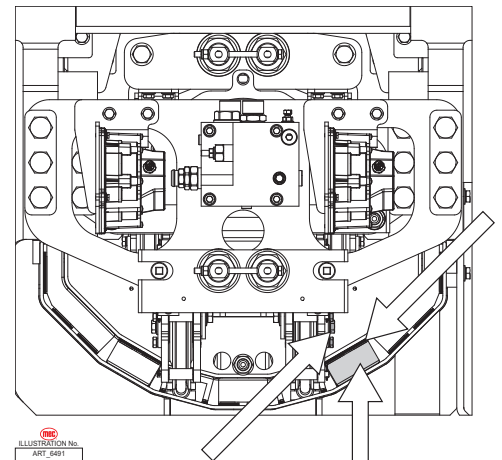

5) Change the Turret Rotation Slewing Ring Gear Oil level

Changing the rotation reduction gear oil

1. Open the control hood and if needed, rotate the turret for better access to the reduction gear.
2. Place a suitable sized container under the drain cap. Remove the cap and wait for the oil to drain.
3. Plug the drainage opening and make sure the cap fits tightly. Add oil through the opening for adding oil until it reaches the level through the indicator.
4. Lubricate the reduction gear shaft bushes.

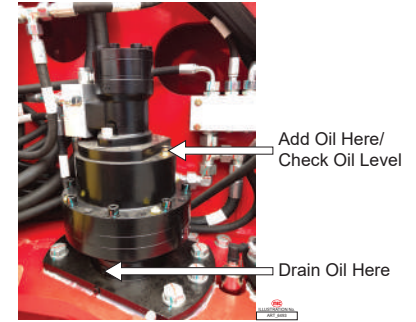

Check the slewing ring gear bearings for wear

The factory setting of the play of the bearings is between 0.05 and 0.25 millimeters.

The slewing ring gear must be replaced if the wear limit value exceeds 2.2 millimeters; to check the bearings for wear, proceed as described below.

1. Make sure that the machine is parked on a flat, level surface. Keep the work area clear of any debris and unauthorized personnel. Make sure that the platform is empty of both personnel and equipment and align the turret to the chassis axis.
2. Lubricate both the turret axial bearing tracks by means of the two grease nipples provided inside, and apply grease manually to the outer teeth of the slewing ring gear using a brush. Refer to page 23 for the grease brands.
3. Check the tightening of the bolts holding the turret rotation slewing ring gear, referring to page 29.
4. Start the machine from the ground controls and fully elevate, but do not extend the main boom and jib. The riser should remain in its stowed position.
5. Place a dial indicator with accuracy of 0.01, between the drive chassis and the turntable at a point that is directly under, or in line with, the boom and no more than 1 inch (2.5 centimeters) from the bearing.
6. Adjust the dial indicator needle to the “zero” position.
7. Elevate the riser, but do not extend it. Move the main boom and jib to horizontal and fully extend.
8. Note the reading on the dial indicator. If the measurement is less than 2.2 millimeters, the bearing is good. Otherwise, the bearing is worn and needs to be replaced.
9. Remove the dial indicator and rotate the turntable 90°.
10. Repeat steps 5 through 9 until the rotation bearing has been checked in at least four equally spaced areas 90° apart.
11. Lower the boom to the stowed position and turn the machine off.
12. Remove the dial indicator from the machine.

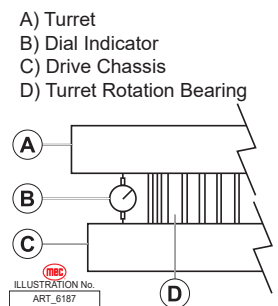

6) Calibrate the Overload sensor

The overload sensor in the platform will show how much weight is in the platform on the diagnostic panel. If the weight in the platform does not exceed the rated load, the machine is safe to operate and will function properly.

If the weight exceeds the rated load, the machine will stop operating and the alarm will beep. The

diagnostic panel will state that the weight in the platform is over the rated amount and to remove excess weight. Once the excess weight has been removed, the machine will operate normally.

The weighting system must be calibrated termly. The interval is 1,000 hours for running or every year. If the weight shown on the diagnostic panel is incorrect, then the sensor must be recalibrated.

1,500 Hour Maintenance

The following maintenance should be done every 1,500 hours of operation.

1) Clean the Fuel Filter mesh element

It is important for operating life of the machine to have a clean fuel suction mesh element. The pressure of fuel suction will be higher when the mesh element is dirty, which will damage the engine and shorten the operating life of the vehicle.

The procedures of cleaning the mesh element as follows:

1. Open the engine hood covering the fuel tank.
2. Loosen the bolts fastening the fuel sucking pipe and pull out the fuel sucking pipe.
3. Remove the mesh element.
4. Clean the mesh slightly. Corrosive chemical solvent are forbidden to use!
5. Refit the mesh after completely cleaning and blowing the mesh with pressured air.

Replacing the mesh should be performed when the mesh is too dirty to clean or damaged.

Two Year Maintenance

The following maintenance should be done every 2 years or every 2,000 hours of operation, whichever comes first.

1) Change the Hydraulic fluid

1. Make sure that the machine is parked on a flat, level surface.
2. Go under the machine to access the hydraulic tank's drainage cap.
3. Place a suitable sized container under the drainage cap. Unscrew the cap and drain out the oil. To speed up the operation, also unscrew the filler cap.
4. Install the plug on the drain port. Fill the tank with hydraulic oil filtered with a 20-micron filter. **Do not overfill!**
5. Look around for enough space for extending and lifting completely.
6. Place a suitable sized container under the function manifold.
7. Disconnect the lifting down hose from B port of function manifold and block the B port with plug.
8. Start the engine, and lift up the main boom completely to move the oil from the cylinder rod chamber into the container.
9. Reconnect the hose.
10. Repeat the step 5-9 for moving the hydraulic oil out from the other cylinder rod chamber.

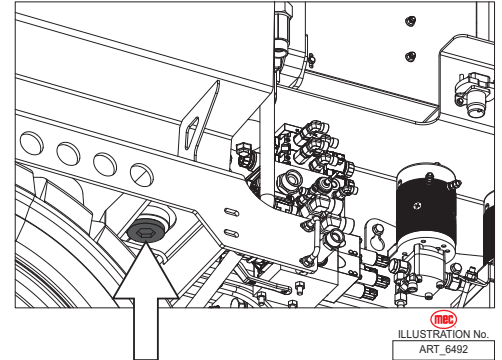

Check the hydraulic oil level after you are finishing and if the hydraulic oil level is low, add additional hydraulic fluid. Refer to page 22 for details on checking the hydraulic oil level.

2) Replace the Air Filter element

1. Follow the procedure for removing the air filter element as described on page 30.
2. Hold the air filter element by means of two fingers in the grips and pull to separate it from its seat.
3. Thoroughly wipe the inside the filter housing with a damp cloth. Avoid using aggressive solvents or chemical products as these can damage the filter casing.
4. Install a new filter element. Grease the outer gasket of the new filter element slightly with silicone grease.

3) Adjust the Wire tightness

1. Take off the cover on the turntable while the main boom is retracted and lowered completely.
2. Measure the dimensions referring to page 24.
3. Position the main boom in a level position and extend outward 4.9 feet (1.5 meters).
4. Take off the cotter pins and lock nuts from the wire rope seating.
5. Clamp the rod of the rope to prevent the rope from rotating.
6. Torque the third boom retract adjusting nuts until the third boom starts to move, alternating between the two wire ropes. Keeping approximately the same amount of thread beyond the adjusting nut.

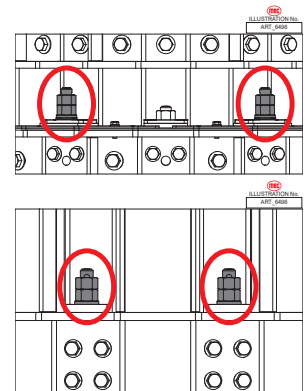

7. Repeat the torque procedure in step 6 to the fourth boom retract wire ropes.
8. Retract the boom half of one meter from the position in step 3.
9. Torque the third boom retract adjusting nuts until the third boom starts to move, alternating between the two wire ropes. Keeping approximately the same amount of thread beyond the adjusting nut.
10. Repeat the torque procedure in step 9 to the fourth boom extend wire ropes.
11. Retract the main booms completely and measure the dimensions to check if the dimensions is in the allowable error on page 24.
12. Install back on the lock nuts and cotter pins.
13. Install back on the cover and dust cover, and then inspect the boom function movement.

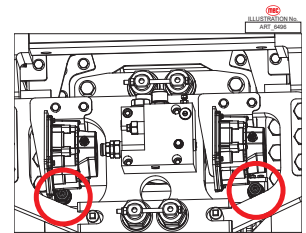
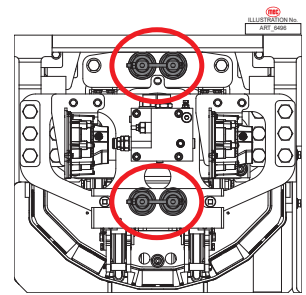

Seven Year Maintenance

The following maintenance should be done every 7 years.

1) Replace the Wire Rope

Mandatory wire ropes and sheaves replacement intervals are 7 years.

- Sheaves and wire rope must be replaced as sets.
- Mandatory wire rope and sheaves replacement must be carried out if anyone of the followed conditions exists, even if the interval between the replacements does not exceeds 7 years.
 - Rusted or corroded wire ropes.
 - Kinked, “bird caged”, or crushed ropes.
 - Ropes at end of adjustment range.
 - Sheaves failing wear out gage inspection.
 - Ropes with 6 total broken wires in one rope lay, 3 in one strand in one rope lay, 1 valley break, or 1 break at any end termination.

Hydraulic Schematic

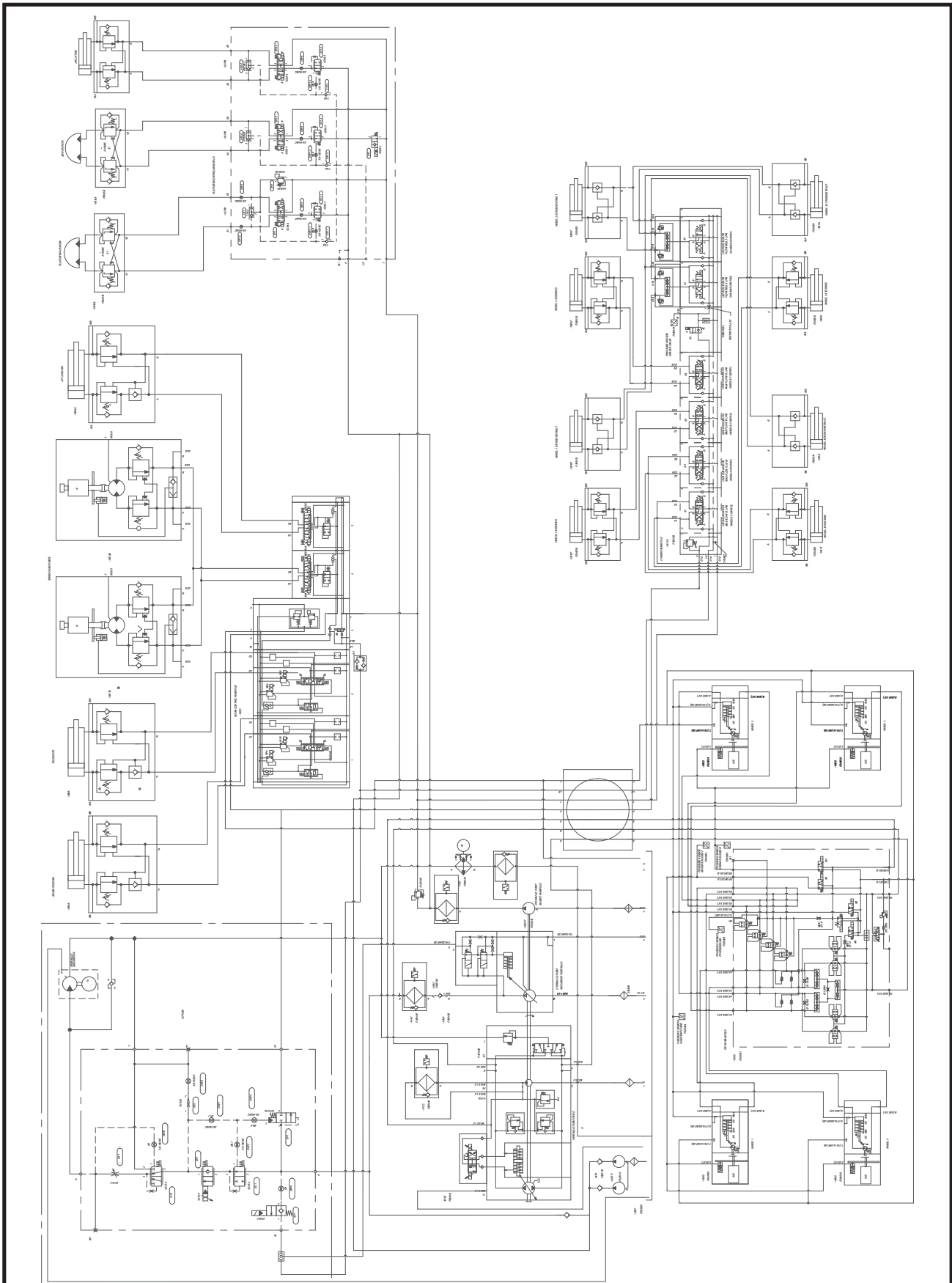



ILLUSTRATION No. 135-RJ
Art 6498

Hydraulic Schematic

Electrical Schematic, Part 1

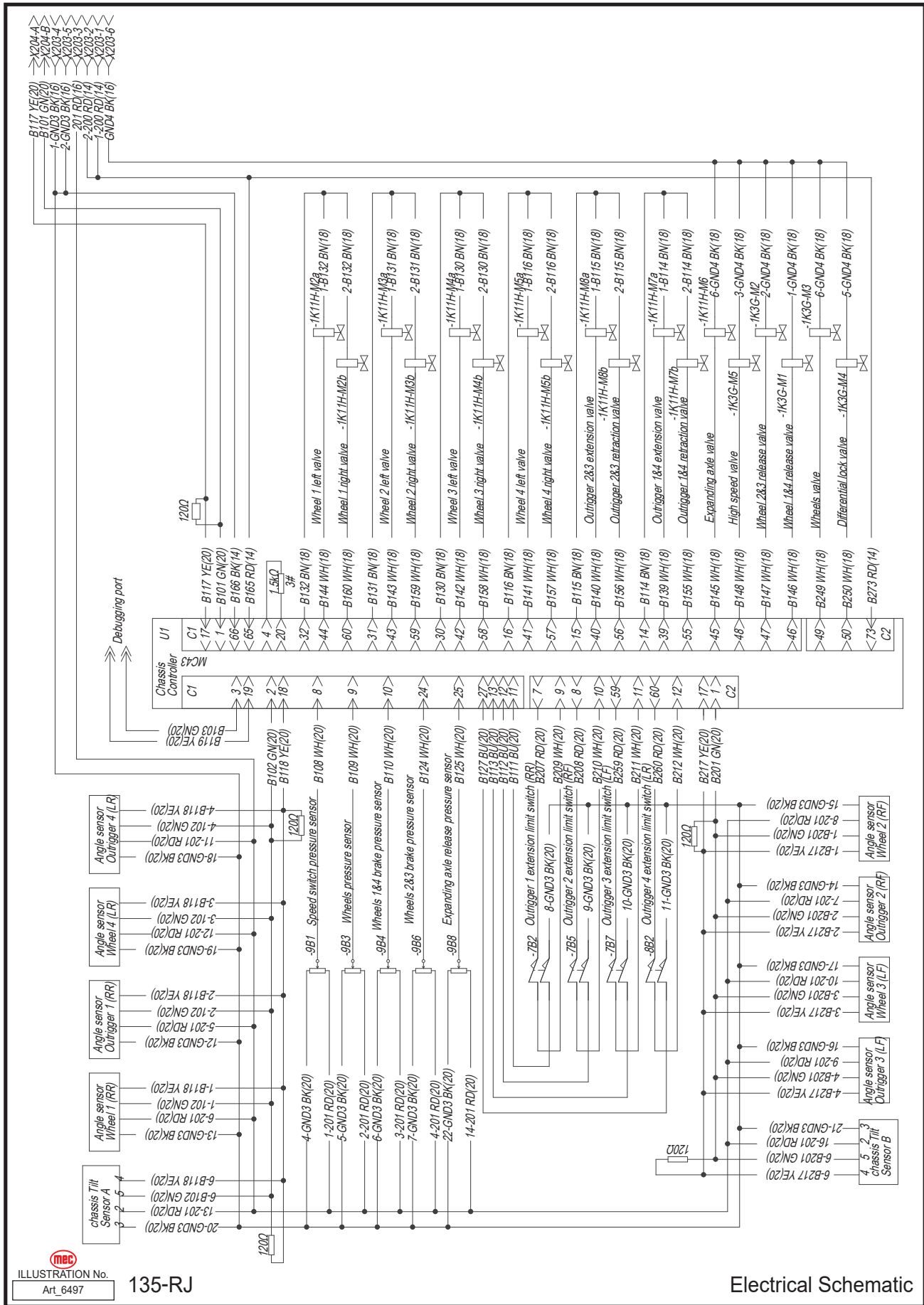

ILLUSTRATION No. Art 6497

135-RJ

Electrical Schematic



Electrical Schematic, Part 2

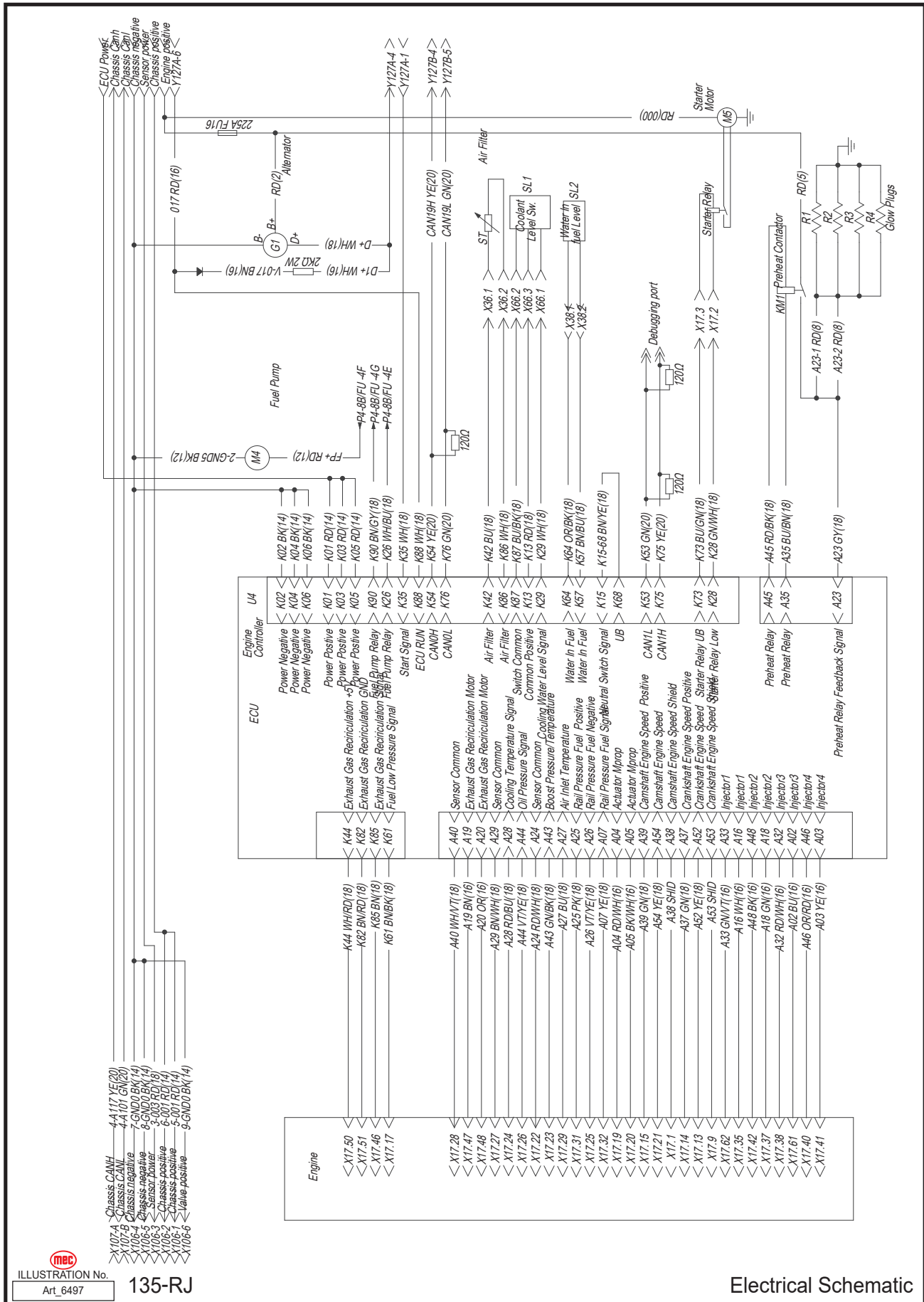

ILLUSTRATION No. Art 6497

135-RJ

Electrical Schematic



Electrical Schematic, Part 3

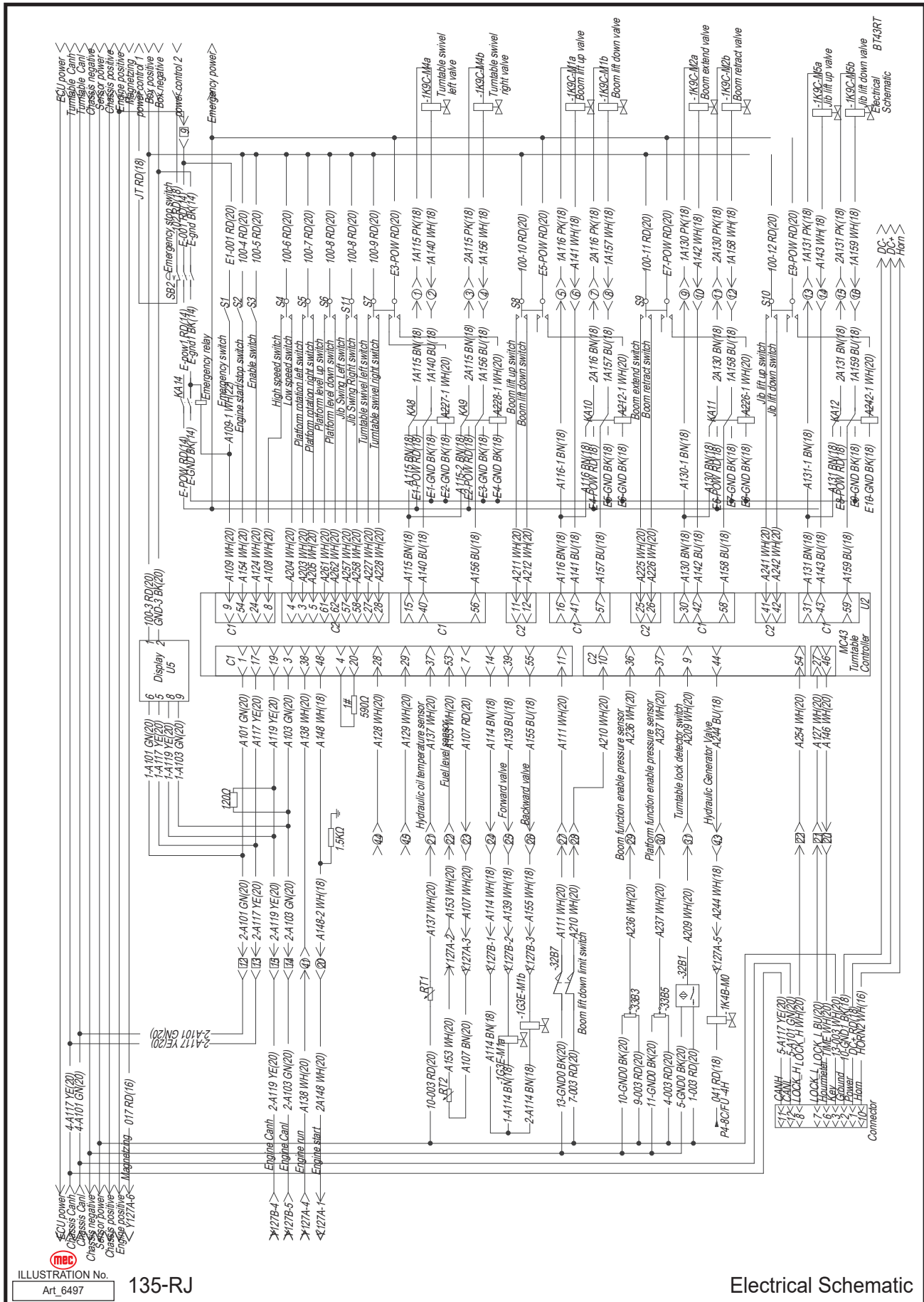

ILLUSTRATION No. Art 6497

135-RJ

Electrical Schematic



Electrical Schematic, Part 4

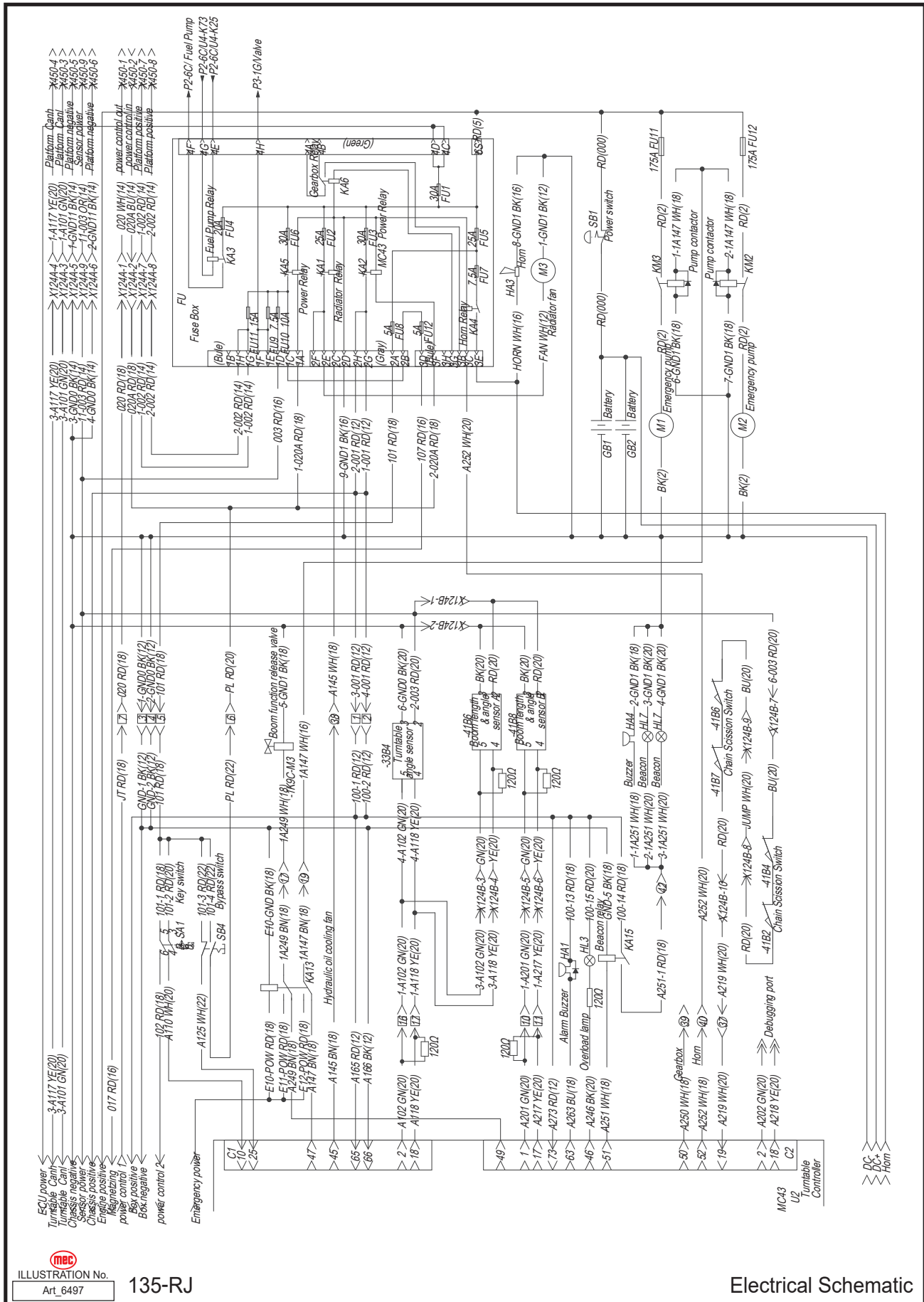

ILLUSTRATION No. Art 6497

135-RJ

Electrical Schematic



Electrical Schematic, Part 5

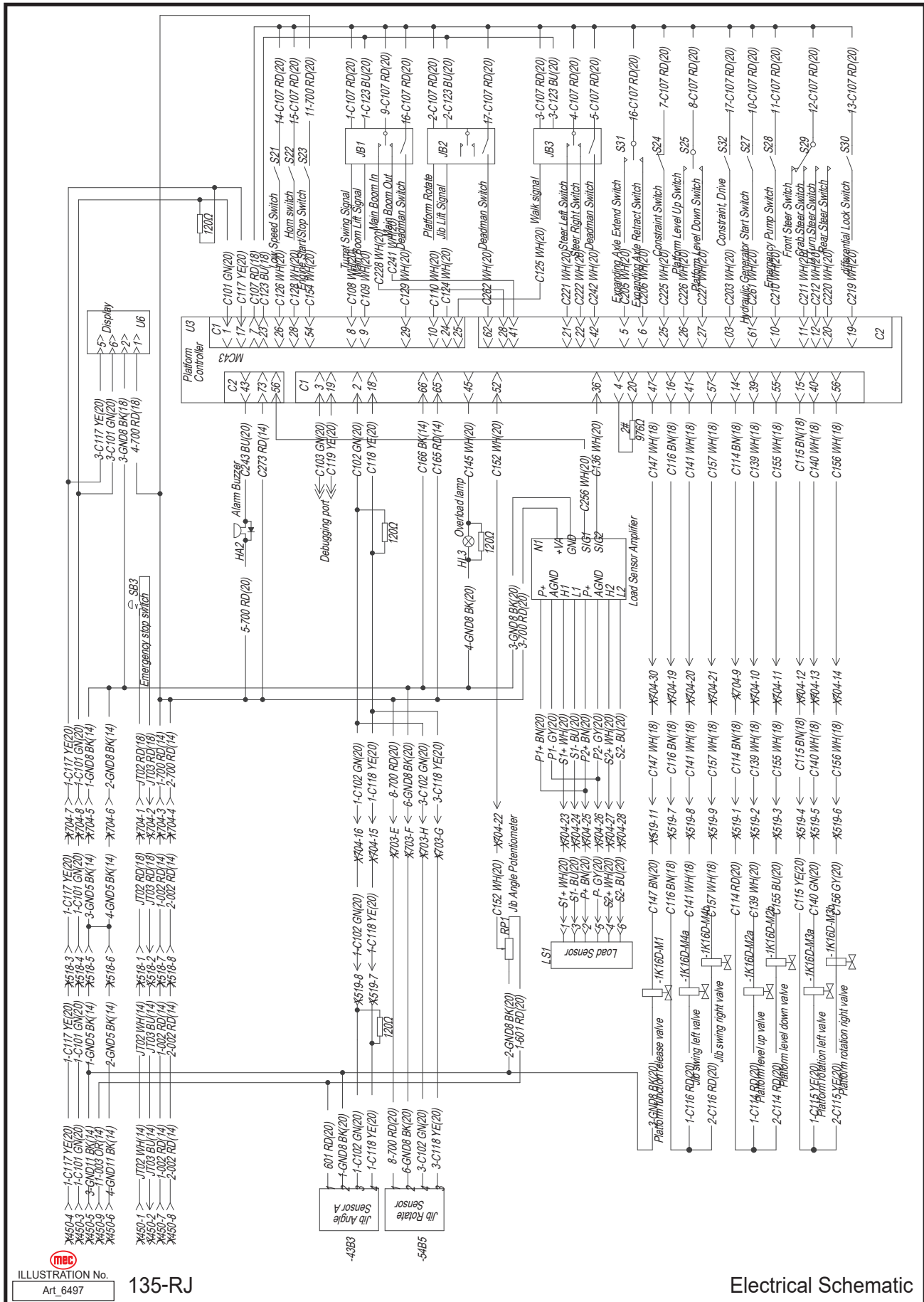

ILLUSTRATION No. Art 6497

135-RJ

Electrical Schematic



THIS PAGE HAS BEEN INTENTIONALLY LEFT BLANK

Parts Introduction

This Parts sections consists of illustrated parts sections and is designed to provide you, the customer, with illustrations and the list of associated parts needed to properly maintain the MEC self-propelled aerial work platform. When used in conjunction with the Service section in this manual and the Operator's Manual (provided separately), this manual will assist you in making necessary adjustments and repairs, and identifying and ordering the correct replacement parts.

All parts represented here are manufactured and supplied in accordance with MEC quality standards.

We recommend that you use genuine MEC parts to ensure proper operation and reliable performance.

To obtain maximum benefits from your MEC Aerial Work Platforms, always follow the proper operating and maintenance procedures. Only trained authorized personnel should be allowed to operate or service this machine. Service personnel should read and study the Operator's, and the Service and Parts Manuals in order to gain a thorough understanding of the unit prior to making any repairs.

Left Front and Right Rear Axle Installation

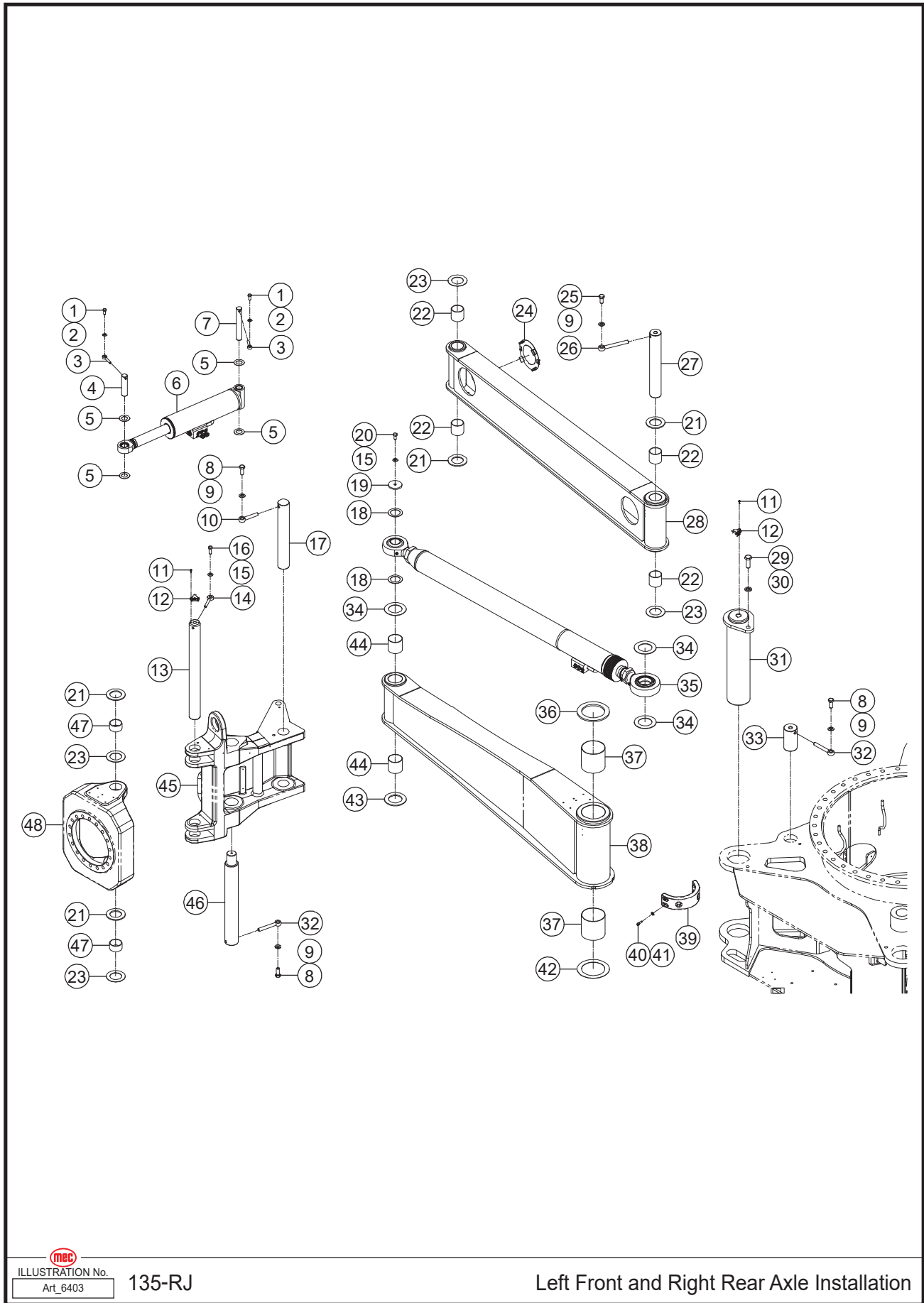

 ILLUSTRATION No. 135-RJ
Art_6403

Left Front and Right Rear Axle Installation

Item	Part Number	Description	Qty.
1	50033	Screw HHCS M10-1.50 × 25 ZP	4
2	60444	Spring Washer	4
3	43024	Pin, Lock	4
4	60837	Pin	2
5	60521	Washer, Thrust	8
6	REF	Steer Cylinder Assembly (Refer to page 198)	2
7	60827	Pin	2
8	60068	Screw HHCS M16-2.00 × 40 ZP	6
9	60840	Spring Washer	8
10	60001	Pin, Lock	2
11	60059	Screw SHCS M04-0.70 × 12 ZP	8
12	60618	Angle Sensor	4
13	60474	Pin	2
14	47571	Pin, Lock	2
15	60445	Spring Washer	4
16	60093	Screw HHCS M12-1.75 × 35 ZP	2
17	60835	Pin	2
18	60522	Washer, Thrust	4
19	60742	Cover	2
20	60032	Screw HHCS M12-1.75 × 25 ZP	2
21	60526	Washer, Thrust	8
22	60739	Sleeve Bearing	8
23	60523	Washer, Thrust	8
24	60493	Cover	4
25	60208	Screw HHCS M16-2.00 × 35 ZP	2
26	60003	Pin, Lock	2
27	60825	Pin	2
28	49242	Parallel Guider	2
29	53557	Screw HHCS M20-2.50 × 55 ZP	2
30	47601	Flat Washer	2
31	49243	Pin	2
32	60002	Pin, Lock	4
33	60824	Pin	2
34	60524	Washer, Thrust	6
35	REF	Axle Extend Cylinder Assembly (Refer to page 200)	2
36	60528	Washer, Thrust	2
37	60699	Sleeve Bearing	4
38	49244	Support Arm	2
39	60497	Support	2
40	60127	Screw SHCS M08-1.25 × 25 ZP	8
41	47750	Spring Washer	8
42	60525	Washer, Thrust	2
43	60527	Washer, Thrust	2
44	60700	Sleeve Bearing	4

45	49246	Axle Pivot	2
46	60836	Pin	2
47	60740	Sleeve Bearing	4
48	60530	Knuckle	2

REF – Reference

THIS PAGE HAS BEEN INTENTIONALLY LEFT BLANK

Left Front and Right Rear Axle Components

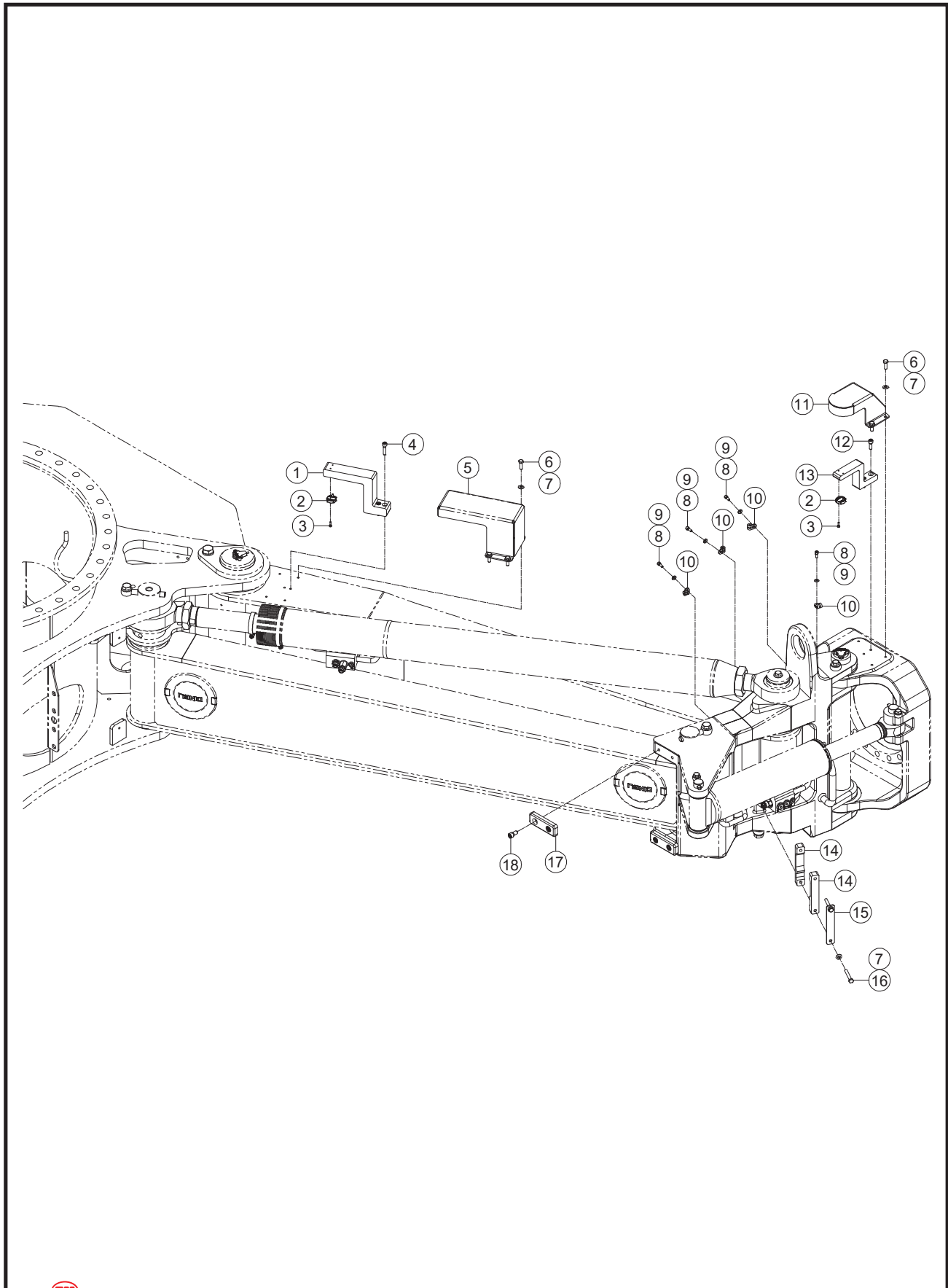

 ILLUSTRATION No. 135-RJ
Art_6405

Left Front and Right Rear Axle Components

Item	Part Number	Description	Qty.
1	60831	Bracket	2
2	60653	Angle Sensor Actuator	4
3	60059	Screw SHCS M04-0.70 × 12 ZP	8
4	53386	Screw SHCS M08-1.25 × 35 ZP	4
5	60833	Housing	2
6	60043	Screw HHCS M08-1.25 × 25 ZP	16
7	47750	Spring Washer	20
8	60041	Screw SHCS M06-1.00 × 16 ZP	8
9	48186	Spring Washer	8
10	60479	Clamp	8
11	49247	Housing	2
12	60127	Screw SHCS M08-1.25 × 25 ZP	4
13	60741	Bracket	2
14	60472	Clamp	4
15	60473	Plate	2
16	60123	Screw HHCS M08-1.25 × 55 ZP	4
17	60743	Spacer	2
18	60112	Screw SHCS M10-1.50 × 20 ZP	4

Left Front and Right Rear Tire & Wheel Installation

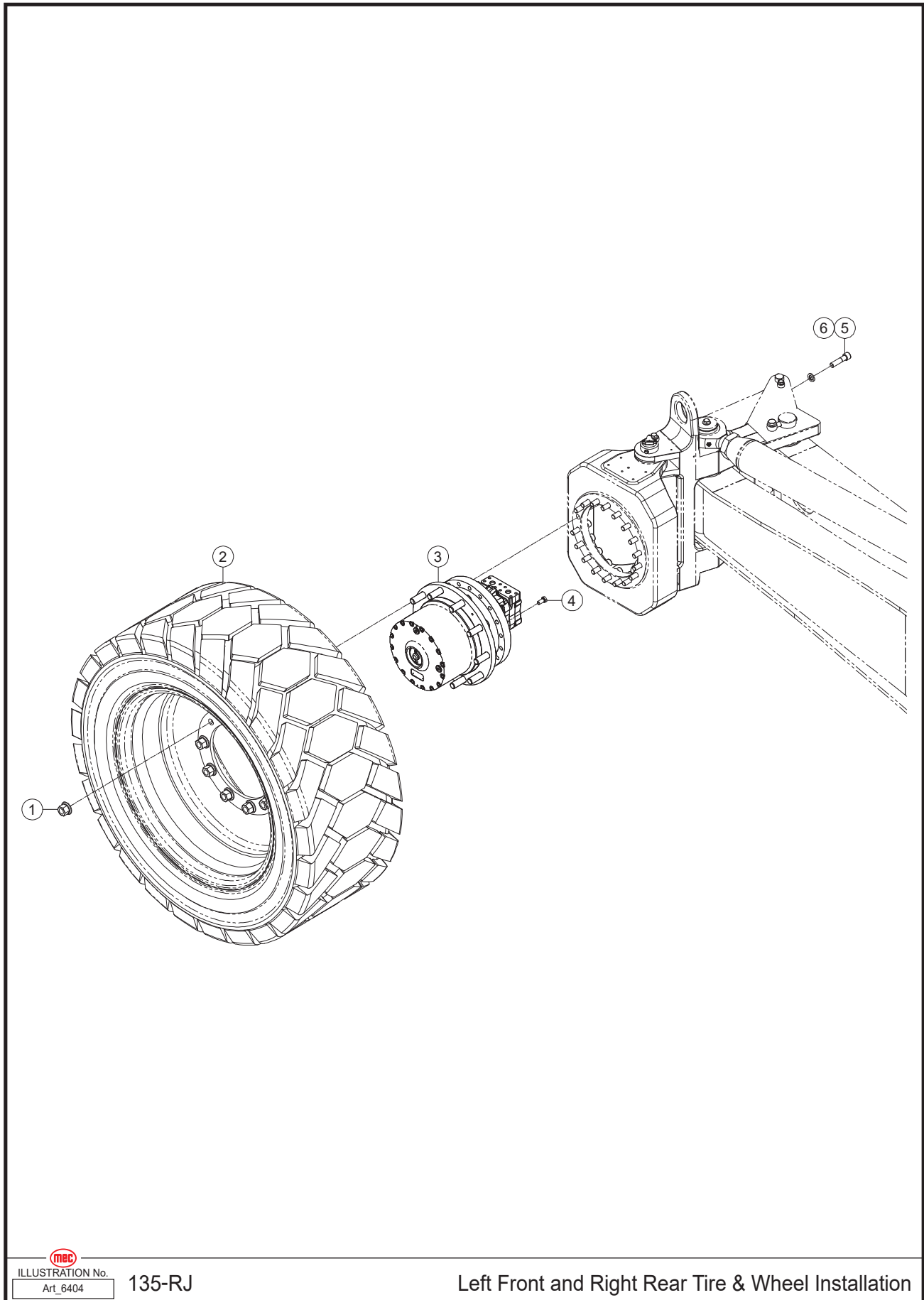
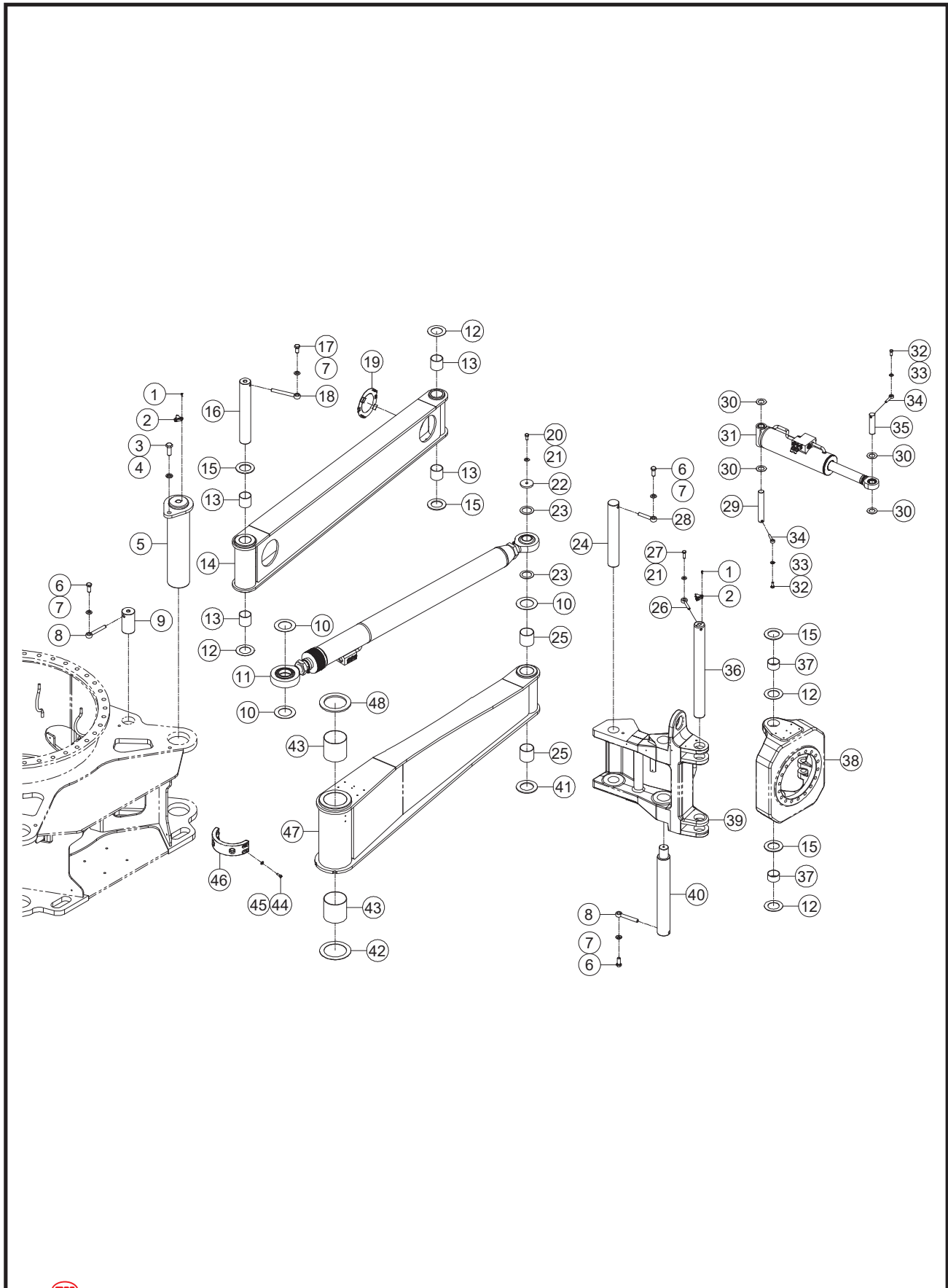



 ILLUSTRATION No. 135-RJ
Art_6404

Left Front and Right Rear Tire & Wheel Installation

Item	Part Number	Description	Qty.
1	53556	Nut NNYL M22-1.50 Flange ZP	20
2	60657	Tire and Wheel Assembly (Left Side)	2
3	60571	Brake and Motor Assembly	2
--	60491	Motor	1
--	60492	Brake	1
4	60032	Screw HHCS M12-1.75 × 25 ZP	4
5	60186	Screw SHCS M16-2.00 × 65 ZP	36
6	60064	Flat Washer	36

Right Front and Left Rear Axle Installation



 ILLUSTRATION No. 135-RJ
Art_6406

Right Front and Left Rear Axle Installation

Item	Part Number	Description	Qty.
1	60059	Screw SHCS M04-0.70 × 12 ZP	8
2	60618	Angle Sensor	4
3	53557	Screw HHCS M20-2.50 × 55 ZP	2
4	47601	Flat Washer	2
5	49243	Pin	2
6	60068	Screw HHCS M16-2.00 × 40 ZP	6
7	60840	Spring Washer	8
8	60002	Pin, Lock	4
9	60824	Pin	2
10	60524	Washer, Thrust	6
11	REF	Axle Extend Cylinder Assembly (Refer to page 200)	2
12	60523	Washer, Thrust	8
13	60739	Sleeve Bearing	8
14	49242	Parallel Guider	2
15	60526	Washer, Thrust	8
16	60825	Pin	2
17	60208	Screw HHCS M16-2.00 × 35 ZP	2
18	60003	Pin, Lock	2
19	60493	Cover	4
20	60032	Screw HHCS M12-1.75 × 25 ZP	2
21	60445	Spring Washer	4
22	60742	Cover	2
23	60522	Washer, Thrust	4
24	60835	Pin	2
25	60700	Sleeve Bearing	4
26	47571	Pin, Lock	2
27	60093	Screw HHCS M12-1.75 × 35 ZP	2
28	60001	Pin, Lock	2
29	60827	Pin	2
30	60521	Washer, Thrust	8
31	REF	Steer Cylinder Assembly (Refer to page 198)	2
32	50033	Screw HHCS M10-1.50 × 25 ZP	4
33	60444	Spring Washer	4
34	43024	Pin, Lock	4
35	60837	Pin	2
36	60474	Pin	2
37	60740	Sleeve Bearing	4
38	60529	Knuckle	2
39	49248	Axle Pivot	2
40	60836	Pin	2
41	60527	Washer, Thrust	2
42	60525	Washer, Thrust	2
43	60699	Sleeve Bearing	4
44	60127	Screw SHCS M08-1.25 × 25 ZP	8

45	47750	Spring Washer	8
46	60497	Support	2
47	49244	Support Arm	2
48	60528	Washer, Thrust	2

REF – Reference

THIS PAGE HAS BEEN INTENTIONALLY LEFT BLANK

Right Front and Left Rear Axle Components

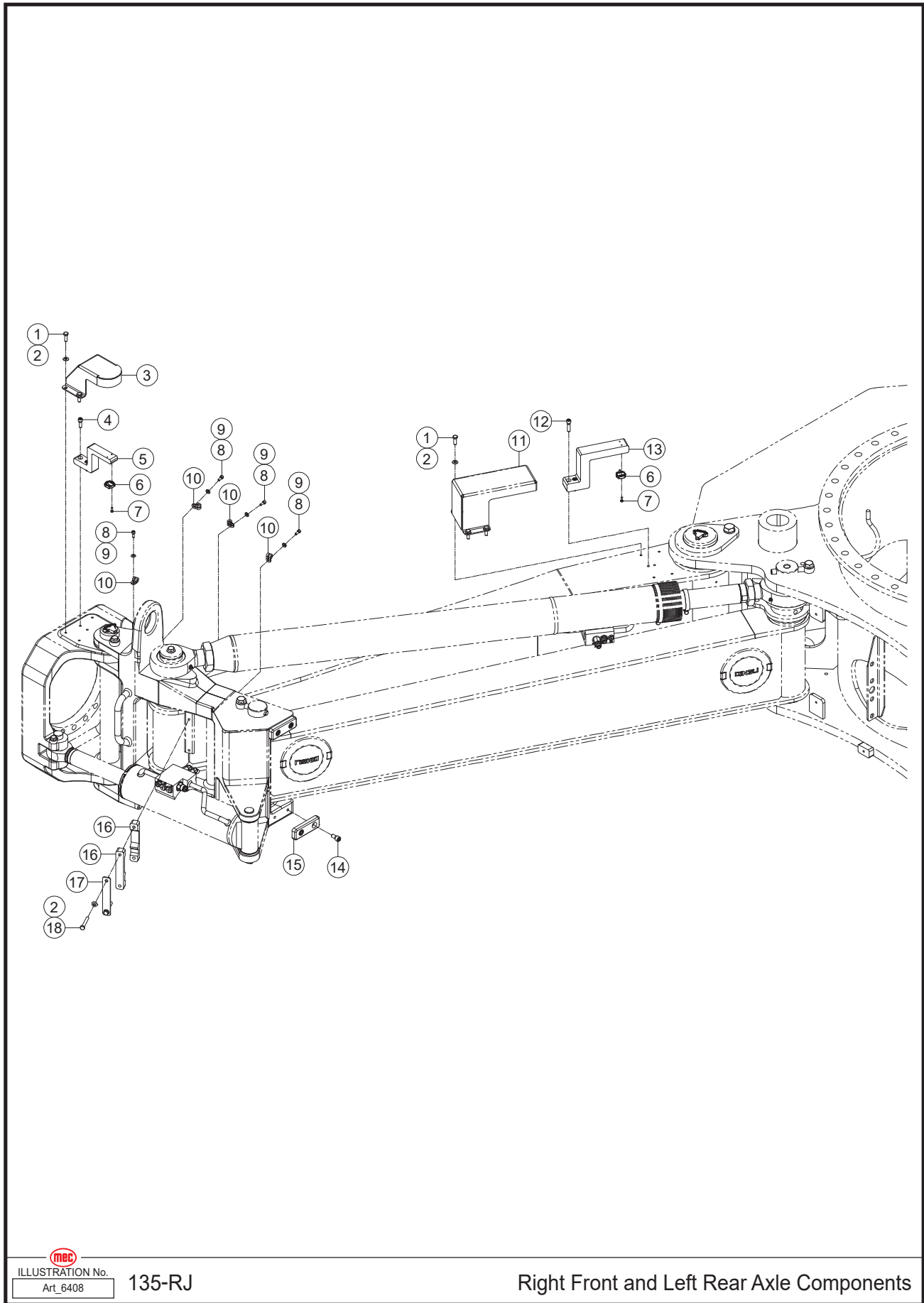

 ILLUSTRATION No. 135-RJ
Art_6408

Right Front and Left Rear Axle Components

Item	Part Number	Description	Qty.
1	60043	Screw HHCS M08-1.25 × 25 ZP	16
2	47750	Spring Washer	20
3	49247	Housing	2
4	60127	Screw SHCS M08-1.25 × 25 ZP	4
5	60741	Bracket	2
6	60653	Angle Sensor Actuator	4
7	60059	Screw SHCS M04-0.70 × 12 ZP	8
8	60041	Screw SHCS M06-1.00 × 16 ZP	8
9	48186	Spring Washer	8
10	60479	Clamp	8
11	60833	Housing	2
12	53386	Screw SHCS M08-1.25 × 35 ZP	4
13	60831	Bracket	2
14	60112	Screw SHCS M10-1.50 × 20 ZP	4
15	60743	Spacer	2
16	60472	Clamp	4
17	60473	Plate	2
18	60123	Screw HHCS M08-1.25 × 55 ZP	4

Right Front and Left Rear Tire & Wheel Installation

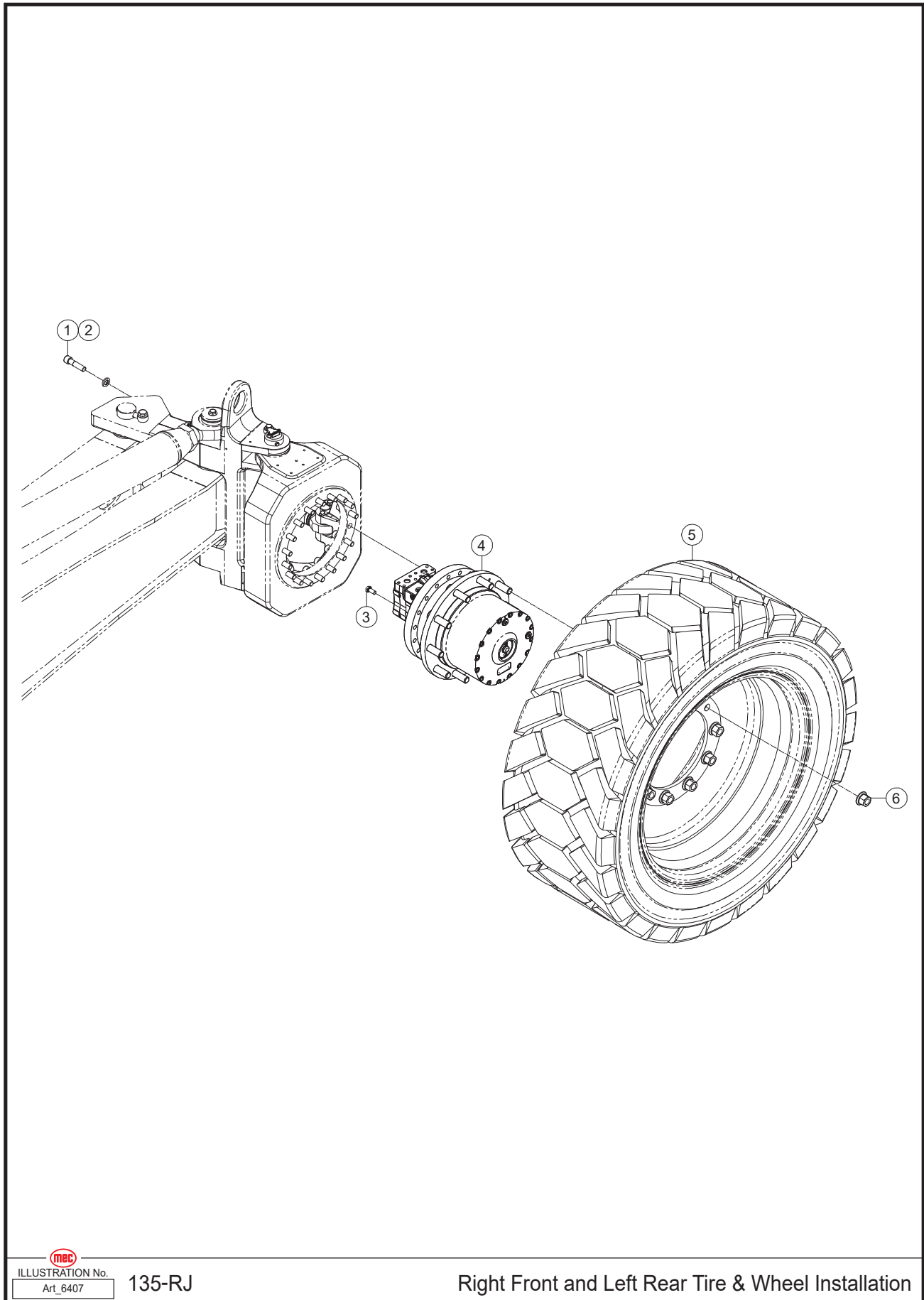
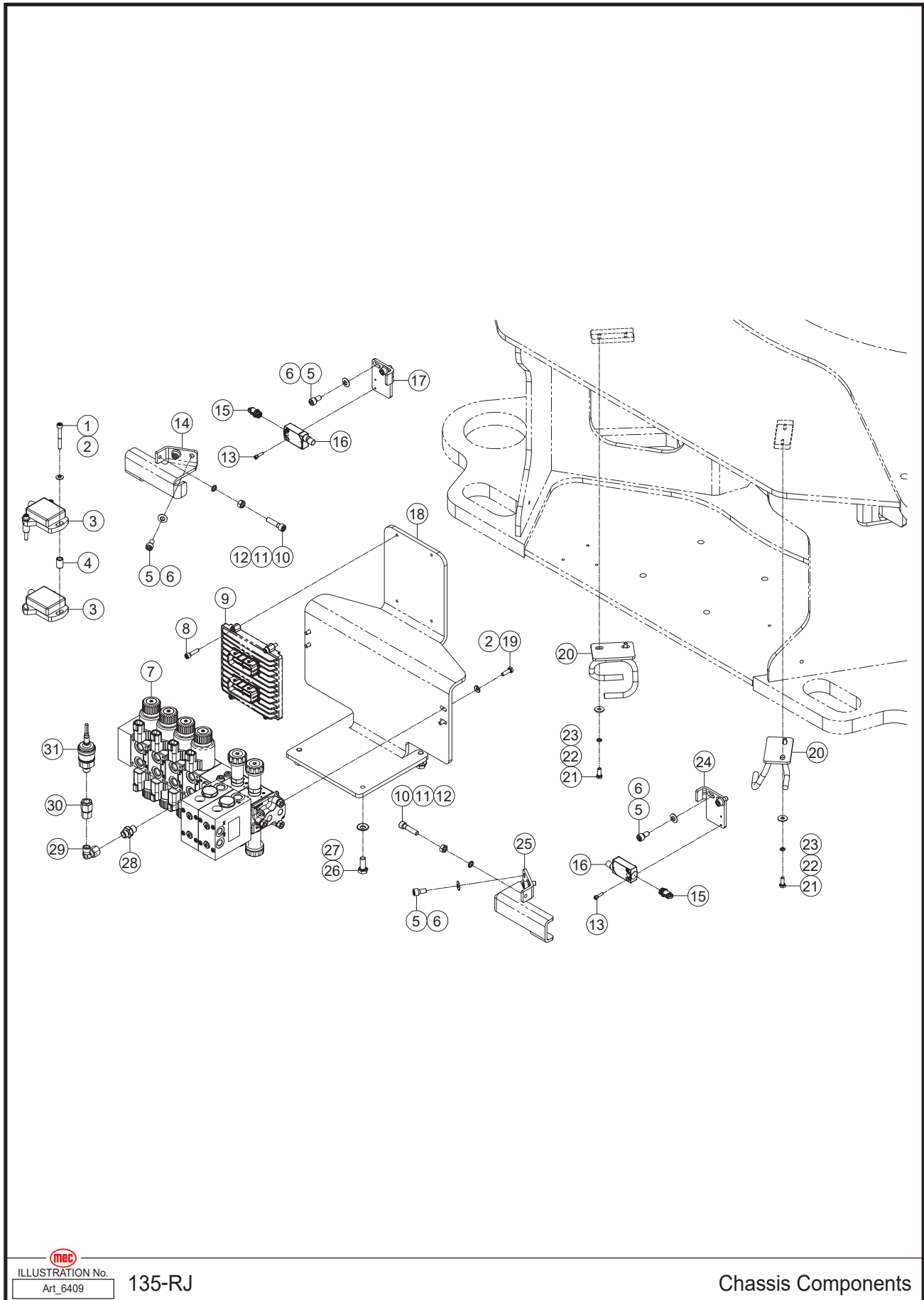



 ILLUSTRATION No. 135-RJ
Art_6407

Right Front and Left Rear Tire & Wheel Installation

Item	Part Number	Description	Qty.
1	60186	Screw SHCS M16-2.00 × 65 ZP	36
2	60064	Flat Washer	36
3	60032	Screw HHCS M12-1.75 × 25 ZP	4
4	60571	Brake and Motor Assembly	2
--	60491	Motor	1
--	60492	Brake	1
5	60658	Tire and Wheel Assembly (Right Side)	2
6	53556	Nut NNYL M22-1.50 Flange ZP	20

Chassis Components, Part 1

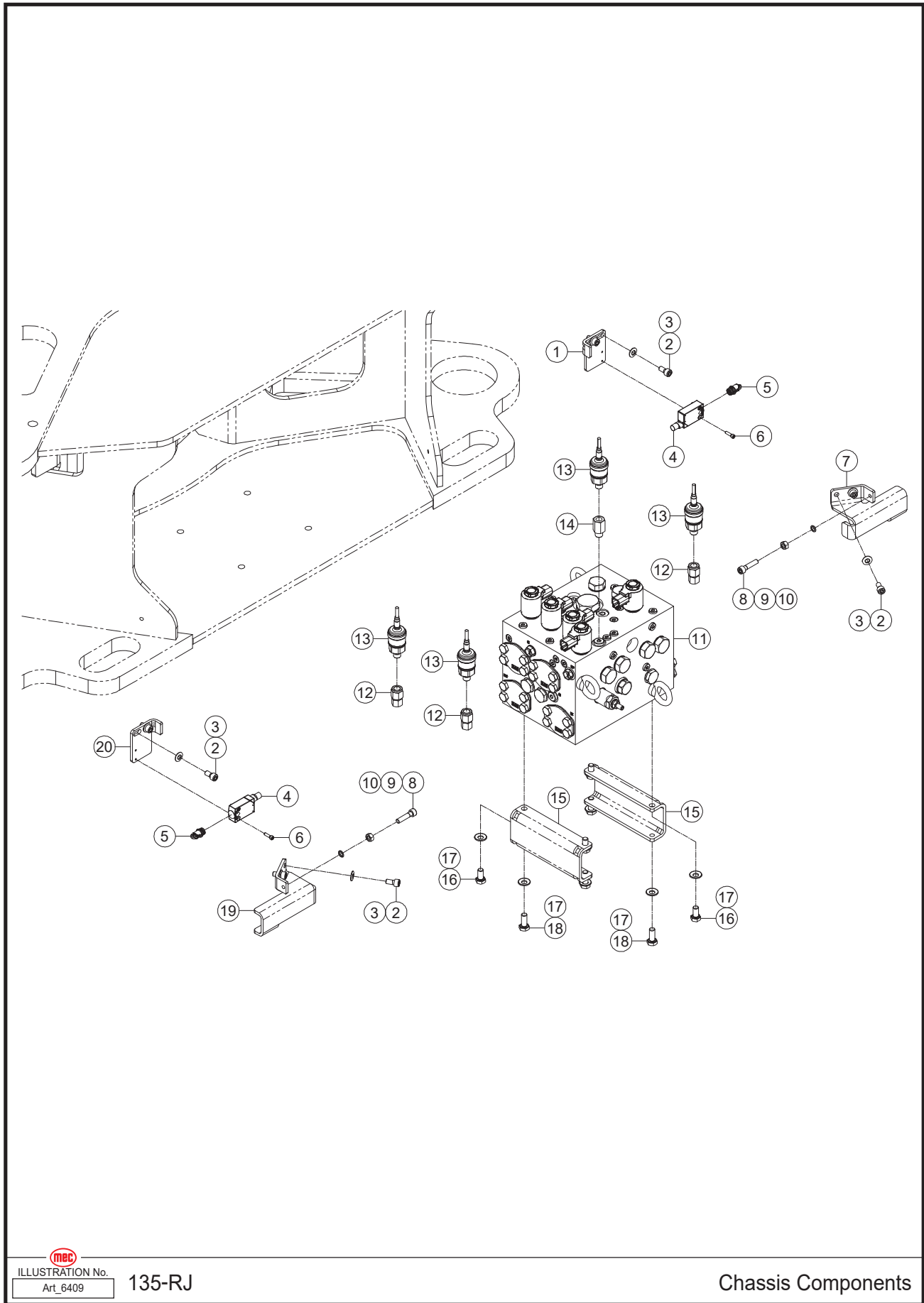



 ILLUSTRATION No. 135-RJ
Art_6409

Chassis Components

Item	Part Number	Description	Qty.
1	60157	Screw SHCS M06-1.00 × 50 ZP	3
2	48186	Spring Washer	7
3	46849	Tilt Sensor	2
4	60801	Spacer	3
5	53379	Screw SHCS M08-1.25 × 16 ZP	8
6	47750	Spring Washer	8
7	60556	Steer Manifold (Refer to page 66)	1
8	53123	Screw SHCS M06-1.00 × 25 ZP	4
9	46913	Control	1
10	53386	Screw SHCS M08-1.25 × 35 ZP	2
11	60010	Nut NHEX M08-1.25 ZP	2
12	60841	Spring Washer	2
13	60005	Screw SHCS M04-0.70 × 16 ZP	4
14	60832	Housing	1
15	60621	Limit Switch Actuator	2
16	60617	Limit Switch	2
17	60734	Bracket, Limit Switch	1
18	60735	Bracket	1
19	50028	Screw HHCS M06-1.00 × 20 ZP	4
20	47582	Support Tubes	2
21	50445	Screw HHCS M06-1.00 × 16 ZP	4
22	53046	WSHR M06 Spring Washer ZP	4
23	50068	WSHR M06 Flat Fender Washer ZP	4
24	60737	Bracket, Limit Switch	1
25	60834	Housing	1
26	50033	Screw HHCS M10-1.50 × 25 ZP	4
27	60444	Spring Washer	4
28	46792	Fitting, Straight	1
29	43077	Fitting, 90°	1
30	60168	Fitting, Straight	1
31	60797	Pressure Sensor	1

Chassis Components, Part 2

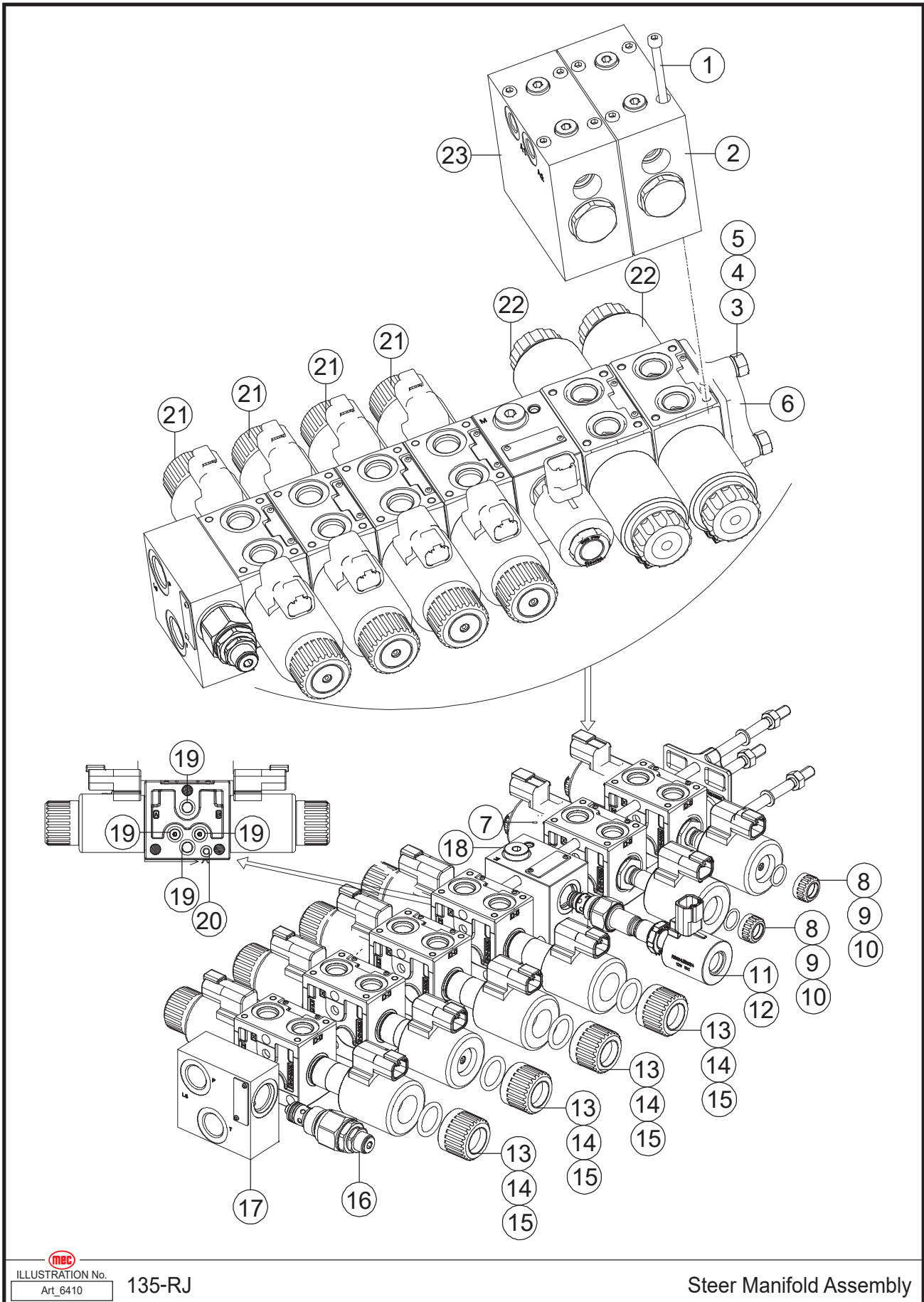



 ILLUSTRATION No. 135-RJ
Art_6409

Chassis Components

Item	Part Number	Description	Qty.
1	60737	Bracket, Limit Switch	1
2	53379	Screw SHCS M08-1.25 × 16 ZP	8
3	47750	Spring Washer	8
4	60617	Limit Switch	2
5	60621	Limit Switch Actuator	2
6	60005	Screw SHCS M04-0.70 × 16 ZP	4
7	60834	Housing	1
8	53386	Screw SHCS M08-1.25 × 35 ZP	2
9	60010	Nut NHEX M08-1.25 ZP	2
10	60841	Spring Washer	2
11	60555	Traction Manifold (Refer to page 68)	1
12	60168	Fitting, Straight	3
13	60797	Pressure Sensor	4
14	47896	Fitting, Straight	1
15	60736	Support	2
16	60019	Screw HHCS M10-1.50 × 20 ZP	4
17	60444	Spring Washer	8
18	50033	Screw HHCS M10-1.50 × 25 ZP	4
19	60832	Housing	1
20	60734	Bracket, Limit Switch	1

Steer Manifold Assembly

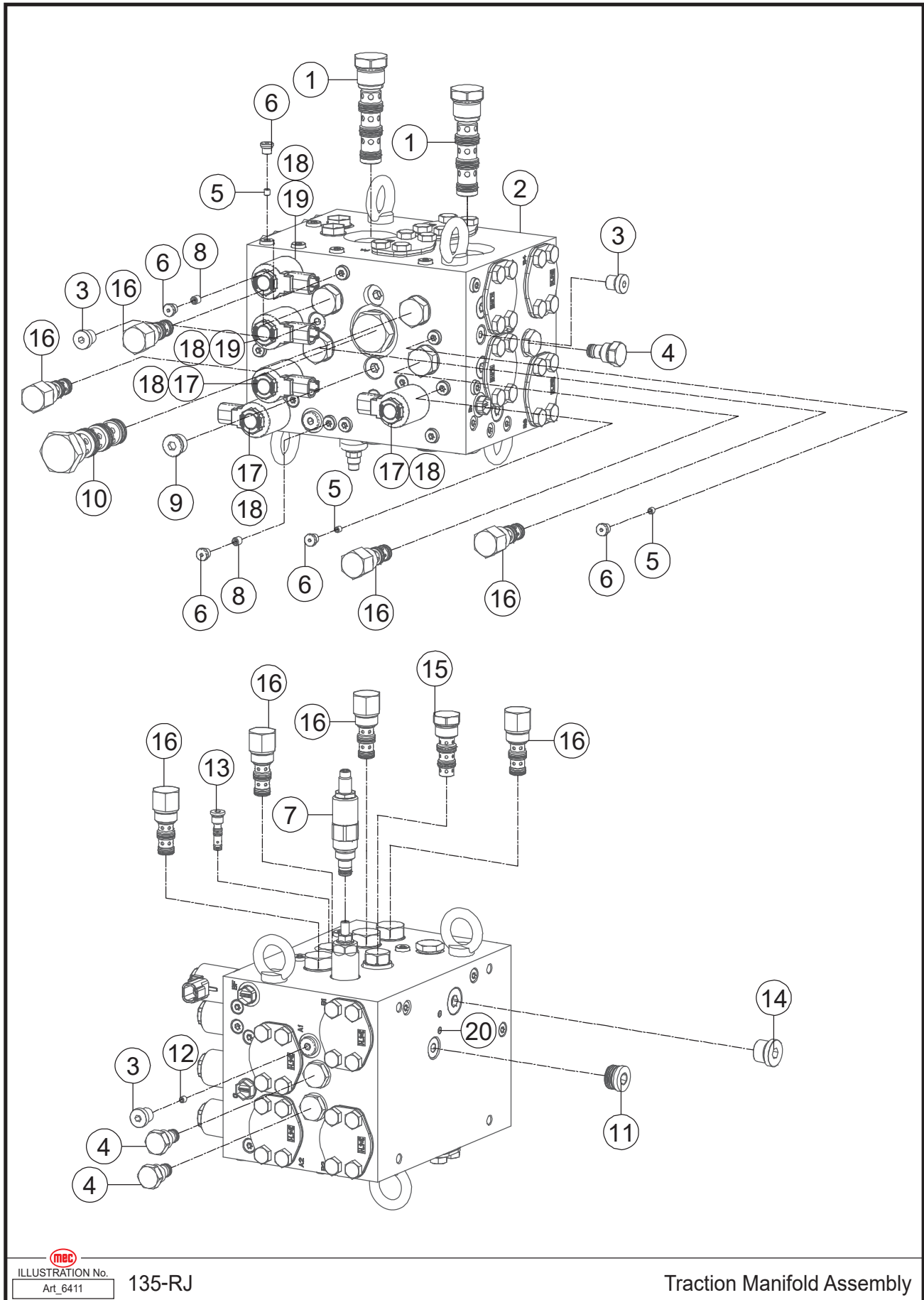



ILLUSTRATION No. 135-RJ
Art_6410

Steer Manifold Assembly

Item	Part Number	Description	Qty.
1	49249	Screw	8
2	49250	Valve, Flow Divider/Combiners	1
3	60299	Lock-Washer	3
4	60300	Tie-Rod	3
5	60298	Nut	3
6	60276	Cover	1
7	60281	Orifice	1
8	60280	Nut	4
9	60292	Seal	4
10	49251	Coil	4
11	60268	Coil	1
12	60314	Cartridge, Solenoid Valve	1
13	60301	Nut	8
14	60304	Seal	8
15	60266	Coil	8
16	60255	Cartridge, Relief Valve	1
17	60269	Body	1
18	60277	Cutting Unit, Steering and Extension/Retraction	1
19	60303	Seal	28
20	60302	Seal	8
21	60278	Work Unit, Steering	4
22	60276	Work Unit, Extension/Retraction	2
23	49252	Valve, Flow Divider/Combiners	1

Traction Manifold Assembly

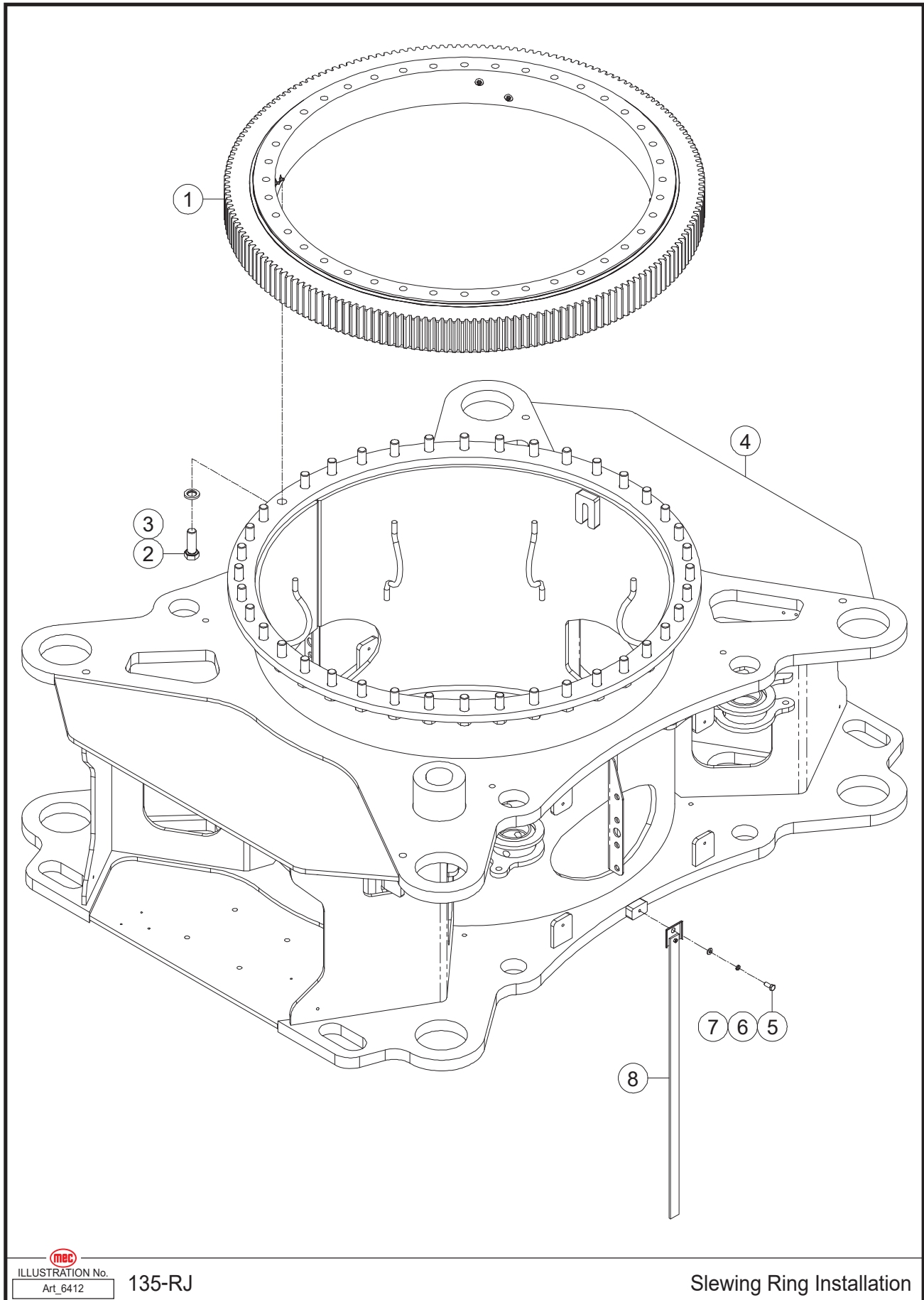



 ILLUSTRATION No. 135-RJ
Art_6411

Traction Manifold Assembly

Item	Part Number	Description	Qty.
1	60257	Cartridge, Flow Divider/Combiner	2
2	60270	Body	1
3	60289	Plug	4
4	60252	Cartridge, Check Valve	4
5	60283	Orifice	3
6	60287	Plug	5
7	60256	Cartridge, Relief Valve	1
8	60284	Orifice	2
9	60285	Plug	1
10	60258	Cartridge, Flow Divider/Combiner	1
11	60290	Plug	1
12	60282	Orifice	1
13	60253	Cartridge, Shuttle Valve	1
14	60286	Plug	1
15	60254	Cartridge, Shuttle Valve	1
16	60263	Cartridge, Logic Valve	8
17	60261	Cartridge, Solenoid Valve	3
18	60268	Coil	5
19	60260	Cartridge, Solenoid Valve	2
20	60288	Plug	2

Slewing Ring Installation

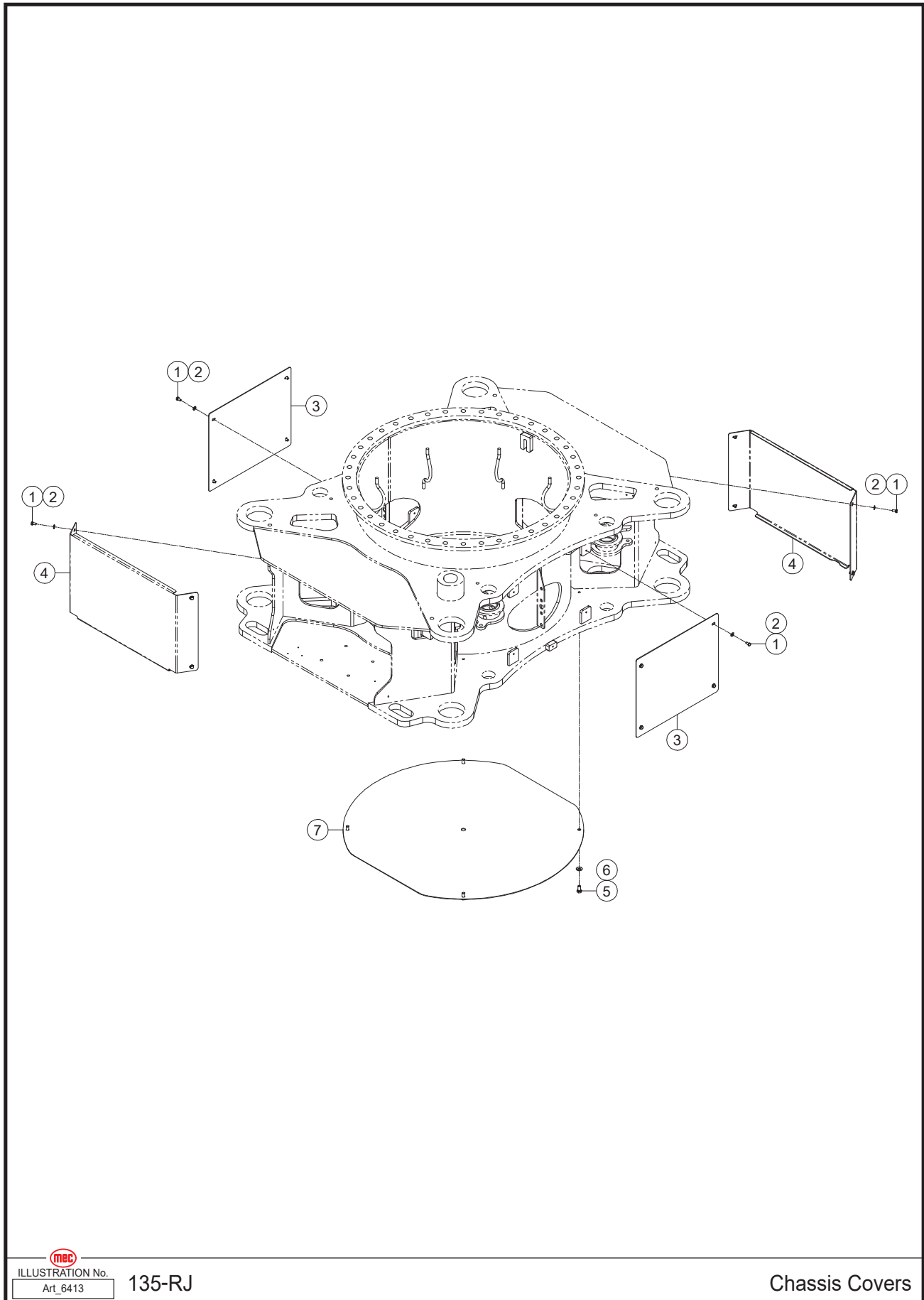



 ILLUSTRATION No. 135-RJ
Art_6412

Slewing Ring Installation

Item	Part Number	Description	Qty.
1	60567	Slewing Ring	1
2	60176	Screw HHCS M20-2.50 × 60 ZP	40
3	47601	Washer, Thrust	40
4	49253	Chassis	1
5	50030	Screw HHCS M08-1.25 × 20 ZP	1
6	60009	WSHR M08 Spring Washer ZP	1
7	60008	WSHR M08 Standard Flat Washer ZP	1
8	47578	Ground Strap	1

Chassis Components



 ILLUSTRATION No. 135-RJ
Art_6413

Chassis Covers

Item	Part Number	Description	Qty.
1	60063	Screw HHCS M08-1.25 × 16 ZP	16
2	47750	Spring Washer	16
3	60829	Cover	2
4	49254	Cover	2
5	60032	Screw HHCS M12-1.75 × 25 ZP	4
6	60445	Spring Washer	4
7	60732	Cover	1

Gearmotor Installation

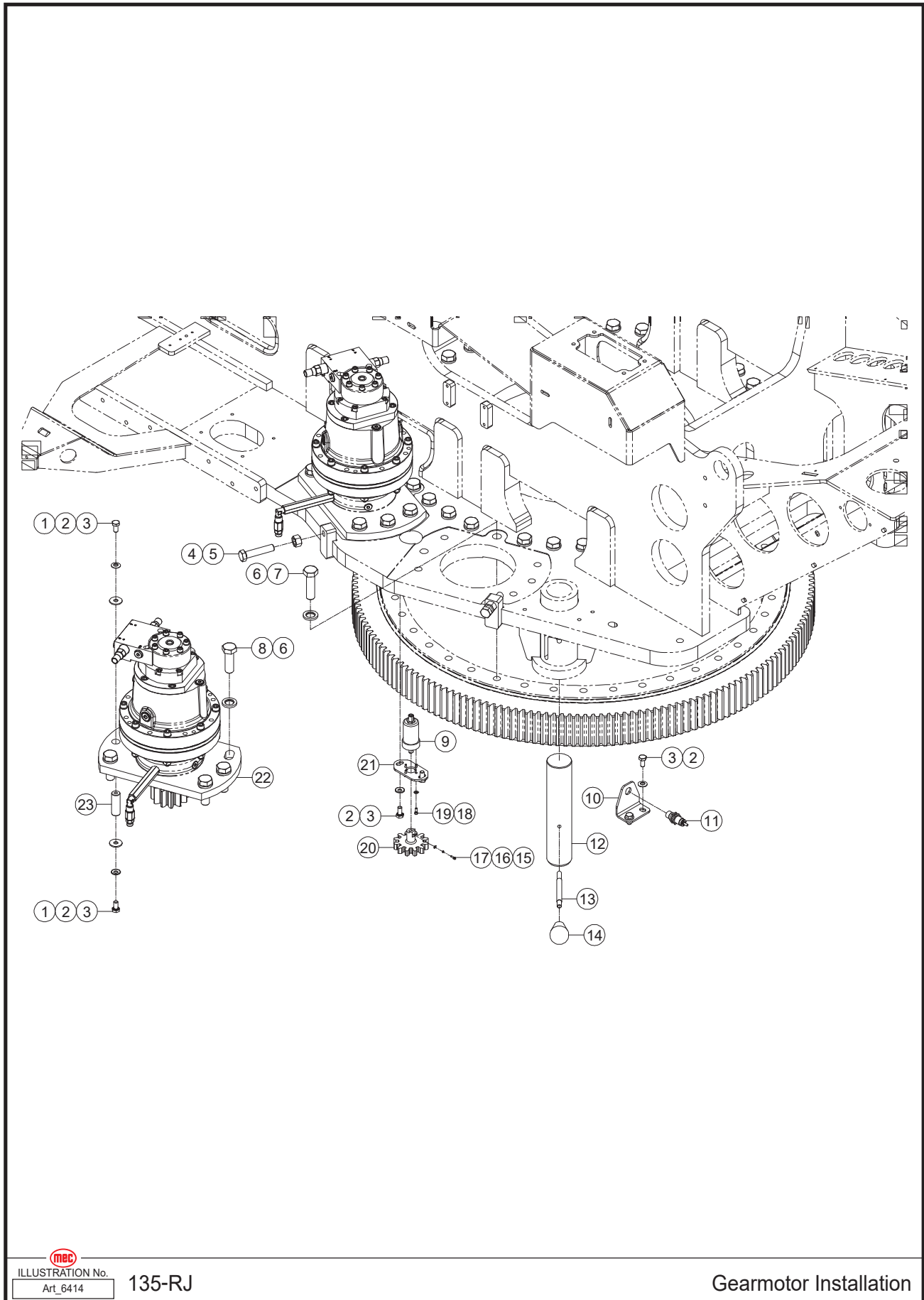

 ILLUSTRATION No. 135-RJ
Art_6414

Gearmotor Installation

Item	Part Number	Description	Qty.
1	53375	WSHR M10 Flat Fender Washer ZP	4
2	60444	Spring Washer	8
3	60019	Screw HHCS M10-1.50 × 20 ZP	8
4	60124	Nut NHEX M16-2.00 ZP	2
5	60199	Screw HHCS M16-2.00 × 75 ZP	2
6	47601	Washer, Thrust	50
7	60108	Screw HHCS M20-2.50 × 70 ZP	40
8	60176	Screw HHCS M20-2.50 × 60 ZP	10
9	60624	Angle Sensor	1
10	60784	Bracket, Switch	1
11	47868	Proximity Switch	1
12	60723	Pin	1
13	47589	Rod	1
14	47590	Handle	1
15	60190	WSHR M03 Standard Flat Washer ZP	1
16	60191	WSHR M03 Spring Washer ZP	1
17	60192	Screw SHCS M03-0.50 × 10 ZP	1
18	60839	Spring Washer	4
19	60059	Screw SHCS M04-0.70 × 12 ZP	4
20	60783	Gear	1
21	60782	Bracket	1
22	47603	Gearmotor	2
--	47604	Motor Assembly	1
--	47605	Valve Block	1
23	60805	Pin	2

Rotary Coupling Installation

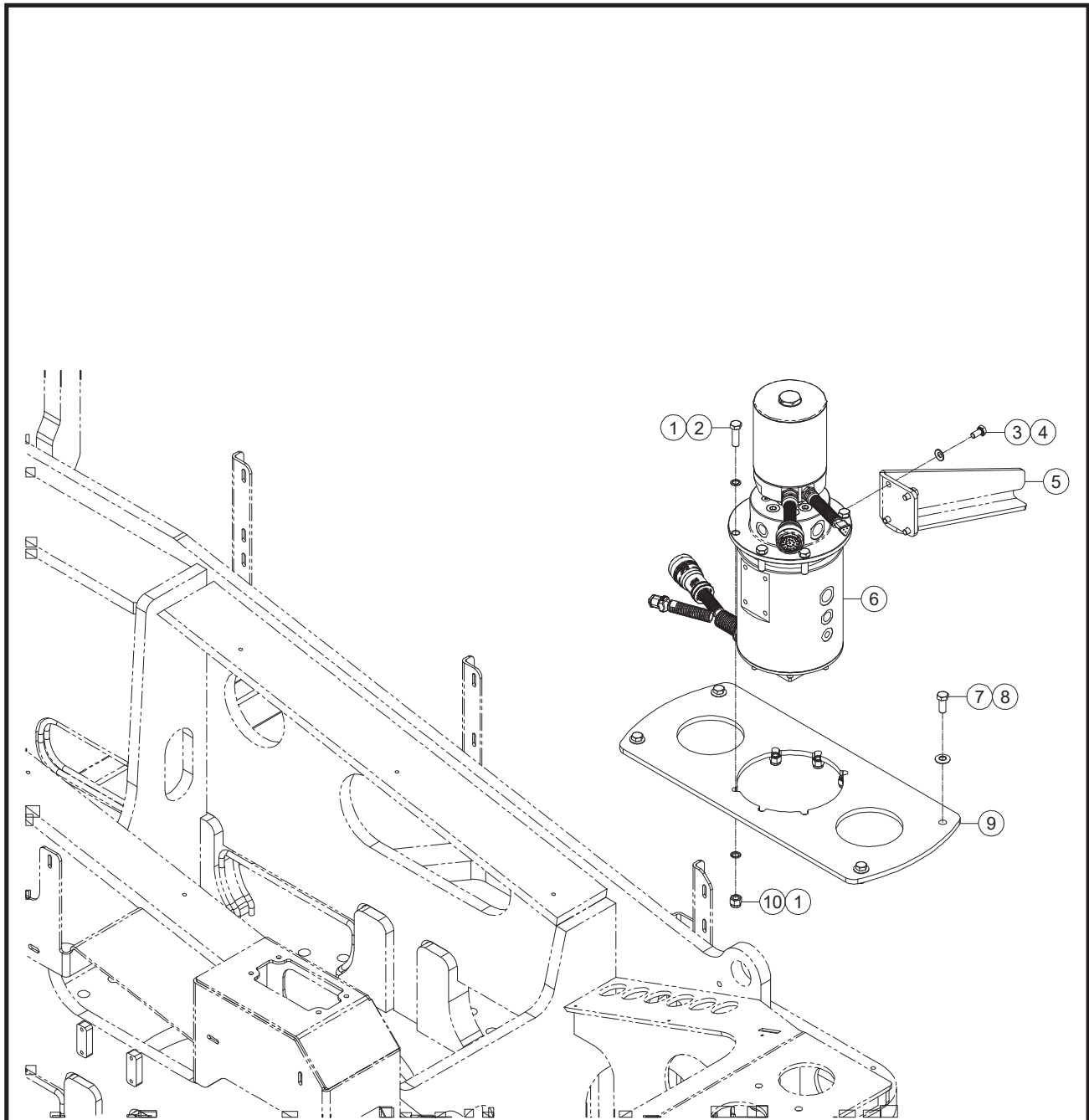
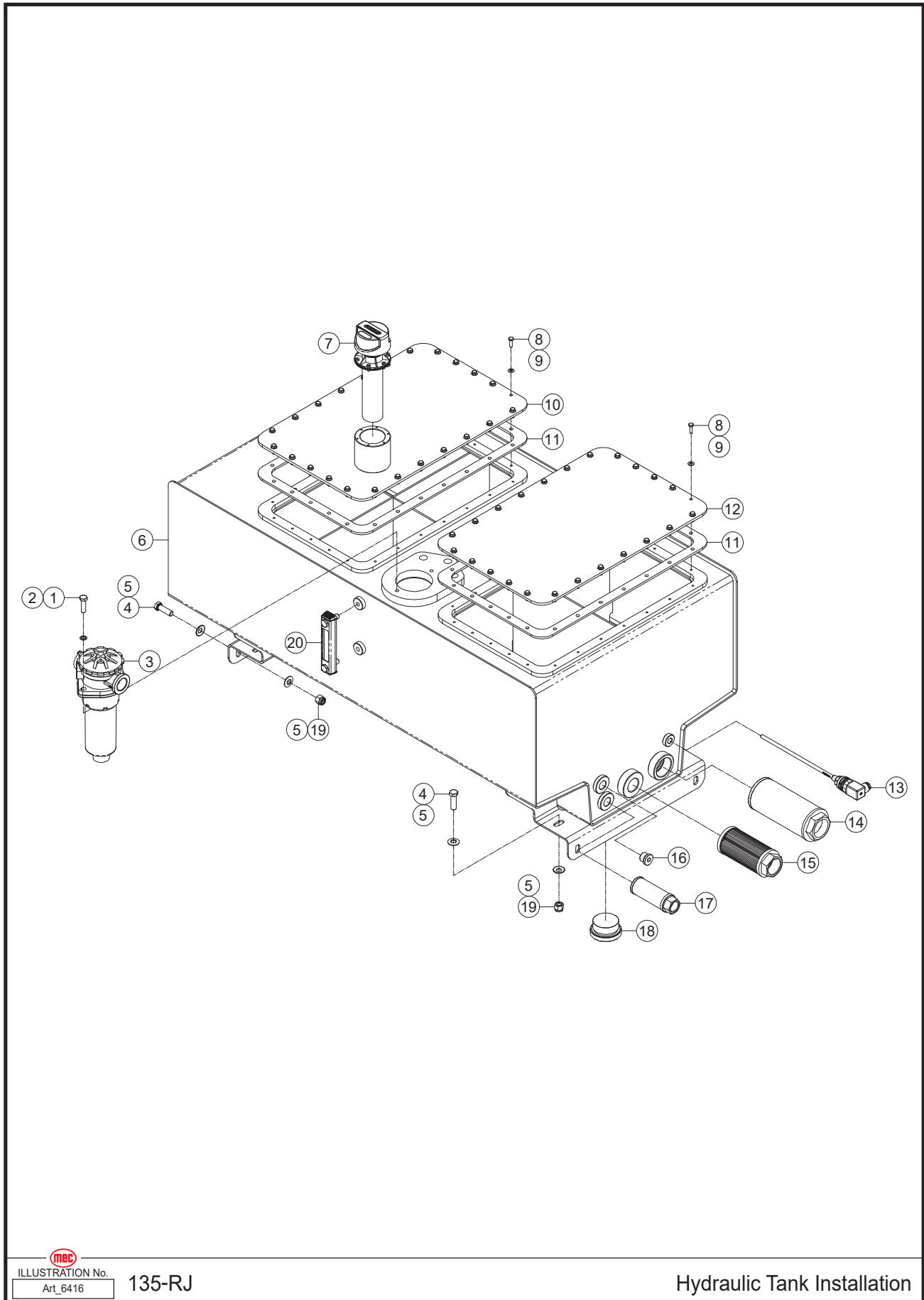



 ILLUSTRATION No. 135-RJ
Art_6415

Rotary Coupling Installation

Item	Part Number	Description	Qty.
1	60843	Spring Washer	12
2	60060	Screw HHCS M12-1.75 × 40 ZP	6
3	60019	Screw HHCS M10-1.50 × 20 ZP	4
4	60444	Spring Washer	4
5	60753	Bracket	1
6	60620	Rotary Coupling Assembly	1
7	60096	Screw HHCS M12-1.75 × 30 ZP	4
8	60445	Spring Washer	4
9	60752	Support	1
10	60074	Nut NNYL M12-1.75 ZP	6

Hydraulic Tank Installation



 ILLUSTRATION No. 135-RJ
Art_6416

Hydraulic Tank Installation

Item	Part Number	Description	Qty.
1	60022	Screw HHCS M10-1.50 × 35 ZP	2
2	60842	Spring Washer	2
3	47762	Filter, Return Oil	1
--	49255	Return Oil Filter Element	1
4	60060	Screw HHCS M12-1.75 × 40 ZP	4
5	60445	Spring Washer	8
6	60566	Hydraulic Tank	1
7	47764	Vent Plug	1
8	50028	Screw HHCS M06-1.00 × 20 ZP	48
9	48186	Spring Washer	48
10	60448	Cover	1
11	60447	Seal	2
12	60446	Cover	1
13	60623	Temperature Sensor	1
14	47767	Filter Cartridge	1
15	43123	Filter Cartridge	1
16	47693	Plug	1
17	47768	Filter Cartridge	1
18	47766	Plug	1
19	60074	Nut NNYL M12-1.75 ZP	4
20	47765	Level Indicator	1

Function Manifold and Filters Installation

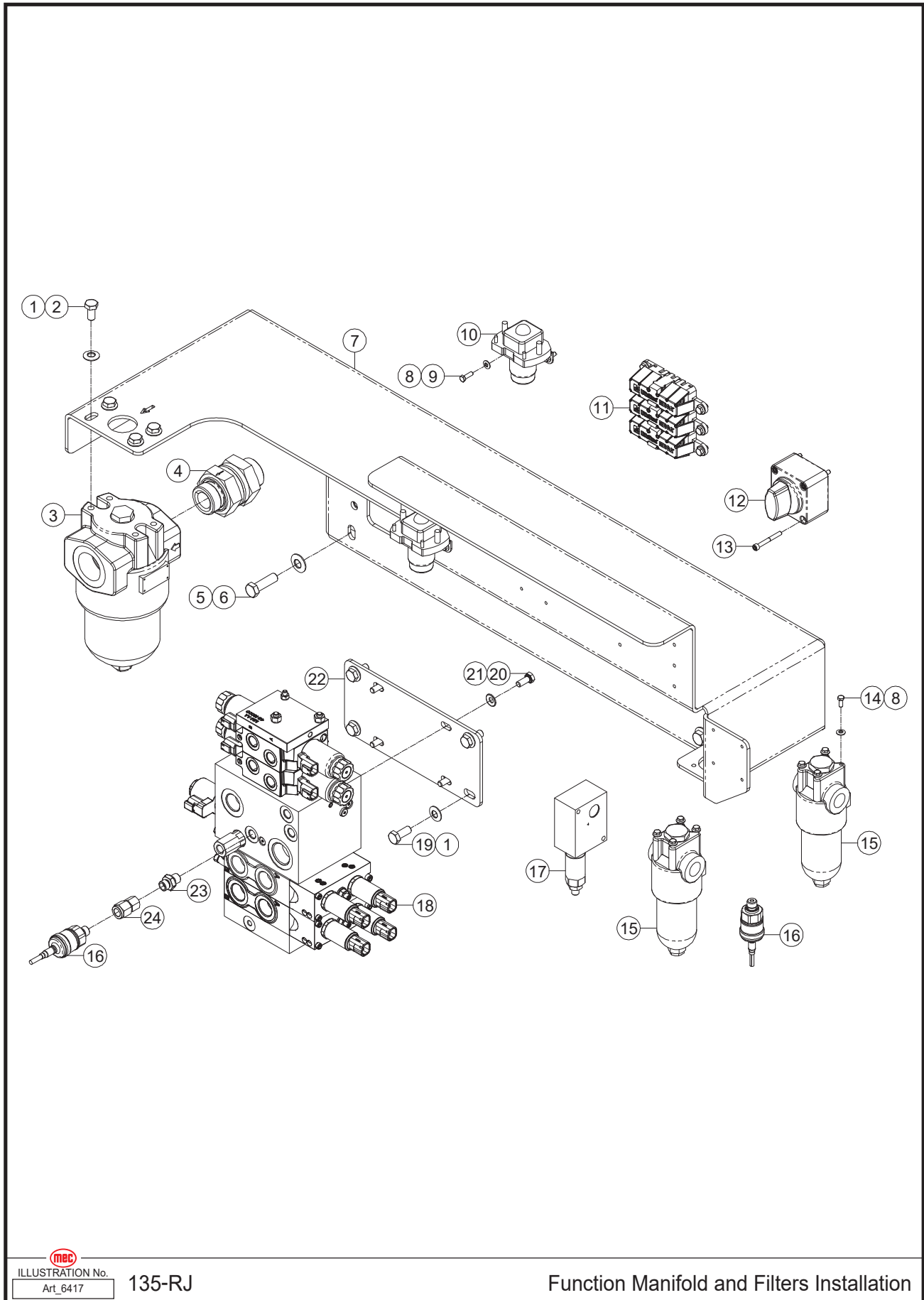

 ILLUSTRATION No. 135-RJ
Art_6417

Function Manifold and Filters Installation

Item	Part Number	Description	Qty.
1	60444	Spring Washer	8
2	60019	Screw HHCS M10-1.50 × 20 ZP	4
3	60494	Filter	1
--	47731	Filter Element	1
4	60790	Check Valve	1
5	60445	Spring Washer	6
6	60060	Screw HHCS M12-1.75 × 40 ZP	6
7	60449	Bracket	1
8	60443	Spring Washer	12
9	53418	Screw HHCS M05-0.80 × 16 ZP	4
10	43800	DC Contactor	2
11	REF	Fuse Holder Assembly (Refer to page 234)	1
12	60726	Power Switch	1
13	60147	Screw SHCS M05-0.80 × 45 ZP	4
14	60111	Screw HHCS M05-0.80 × 12 ZP	8
15	60495	Filter	2
--	49256	Filter Element	1
16	60797	Pressure Sensor	2
17	60435	Relief Valve (Refer to page 82)	1
18	60557	Function Manifold (Refer to page 84)	1
19	50033	Screw HHCS M10-1.50 × 25 ZP	4
20	50030	Screw HHCS M08-1.25 × 20 ZP	4
21	47750	Spring Washer	4
22	60451	Bracket	1
23	46792	Fitting, Straight	1
24	60168	Fitting, Straight	1

REF – Reference

Relief Valve

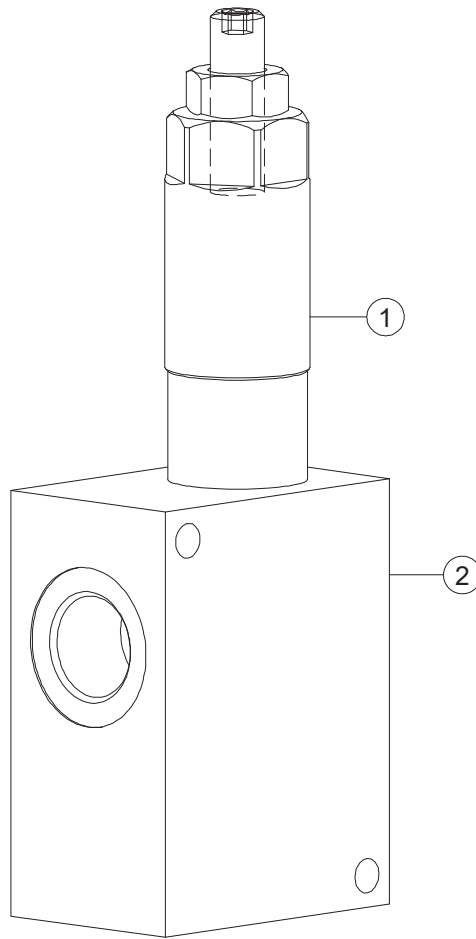

 ILLUSTRATION No. 135-RJ
Art_6418

Relief Valve

Item	Part Number	Description	Qty.
1	60196	Cartridge, Relief	1
2	60197	Body	1

Function Manifold Assembly

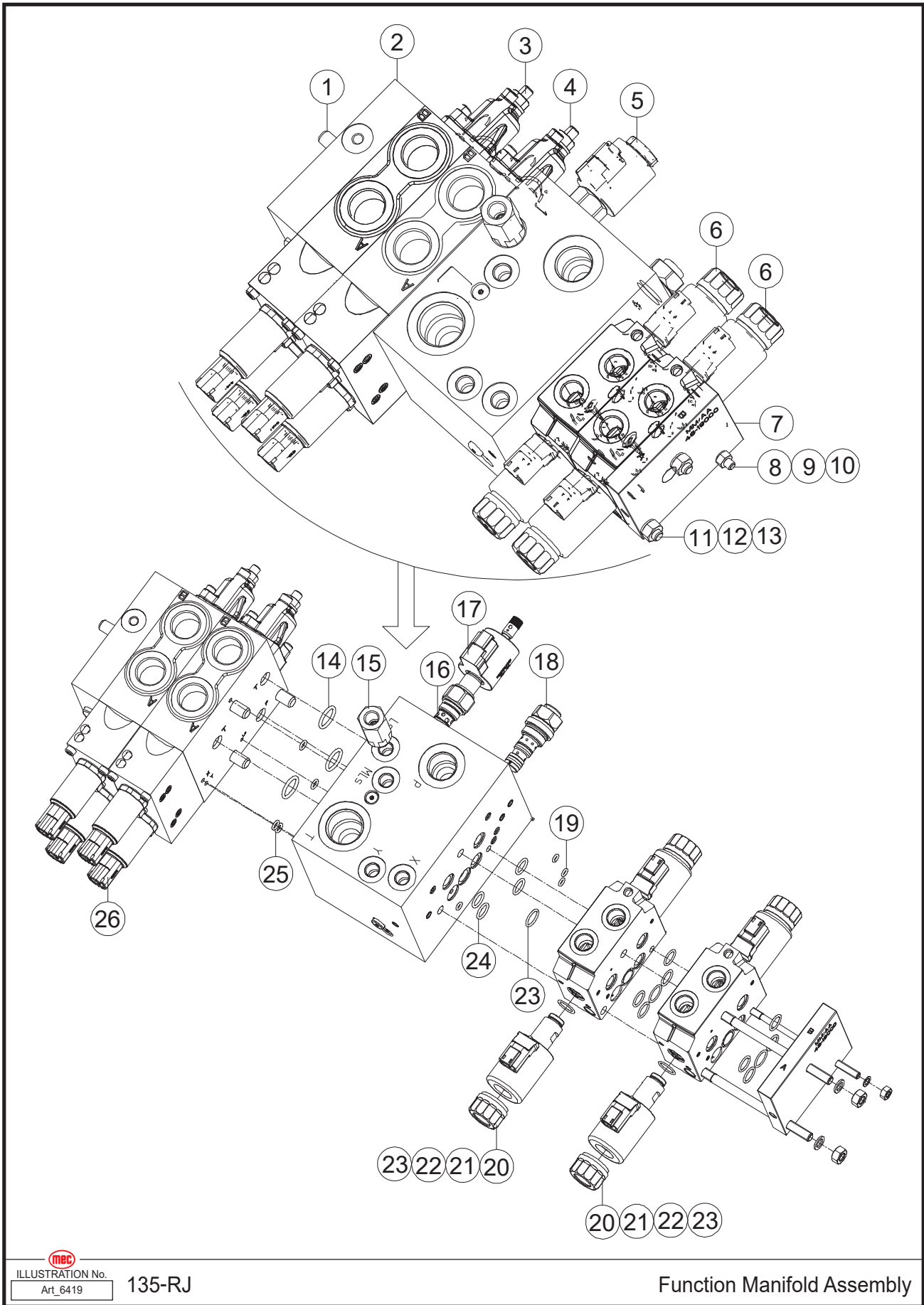
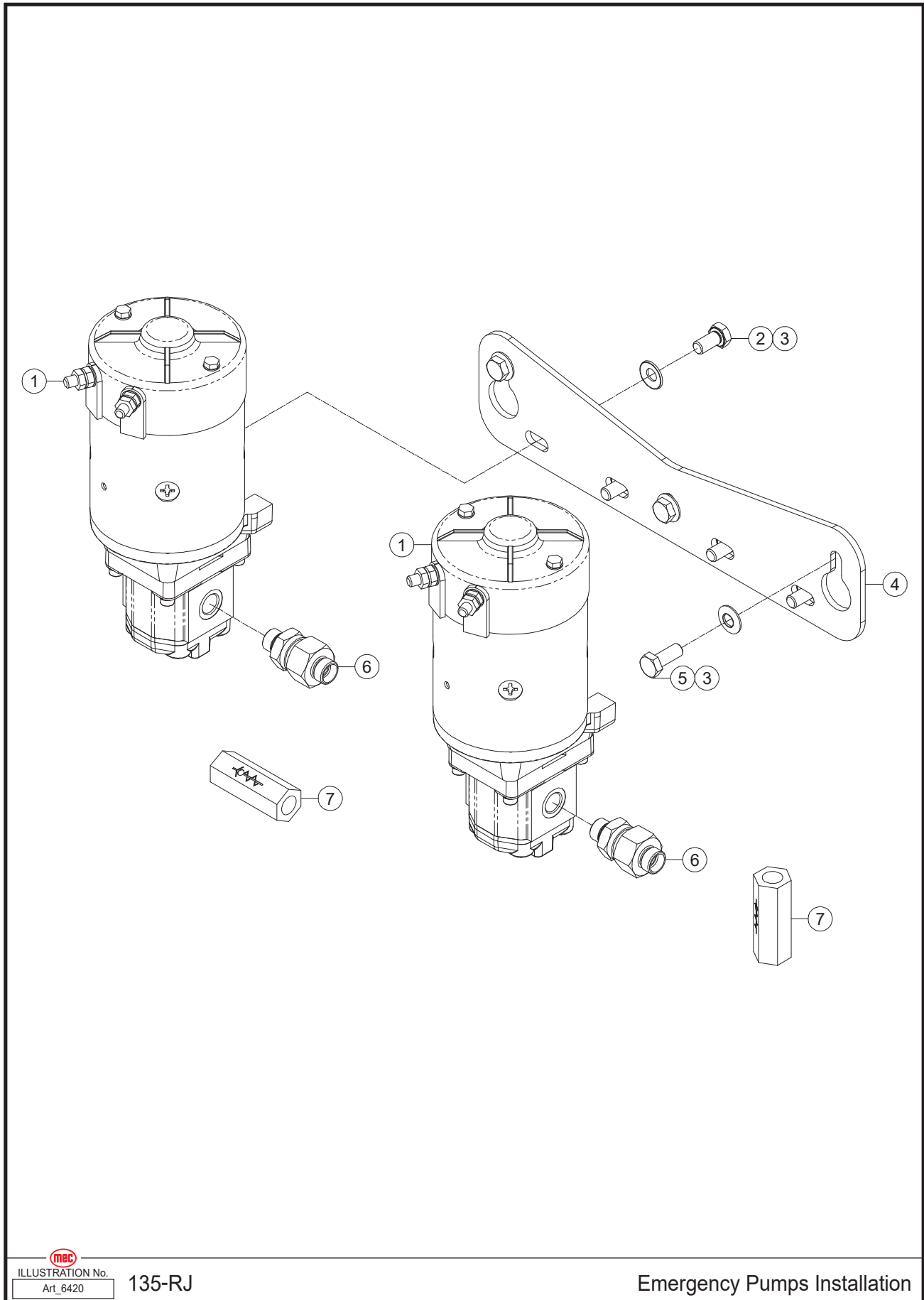



 ILLUSTRATION No. 135-RJ
Art_6419

Function Manifold Assembly

Item	Part Number	Description	Qty.
1	60293	Tie-Rod	3
2	60313	Cover	1
3	60272	Work Unit, Main Boom Lifting	1
4	60311	Work Unit, Main Boom Telescope	1
5	60273	Inlet Unit	1
6	60274	Work Unit, Jib Lifting	2
7	60271	Cover	1
8	60295	Tie-Rod	1
9	60297	Lock-Washer	1
10	60296	Nut	1
11	60294	Tie-Rod	2
12	60299	Lock-Washer	5
13	60298	Nut	5
14	60309	Seal	3
15	60306	Plug, Orifice	1
16	60259	Cartridge, Solenoid Valve	1
17	60264	Coil	1
18	60305	Cartridge, Relief Valve	1
19	60307	Seal	4
20	60279	Nut	4
21	60265	Coil	4
22	60262	Cartridge, Proportional Valve	4
23	60291	Seal	5
24	60308	Seal	4
25	60310	Seal	4
26	49257	Coil	4

Emergency Pumps Installation

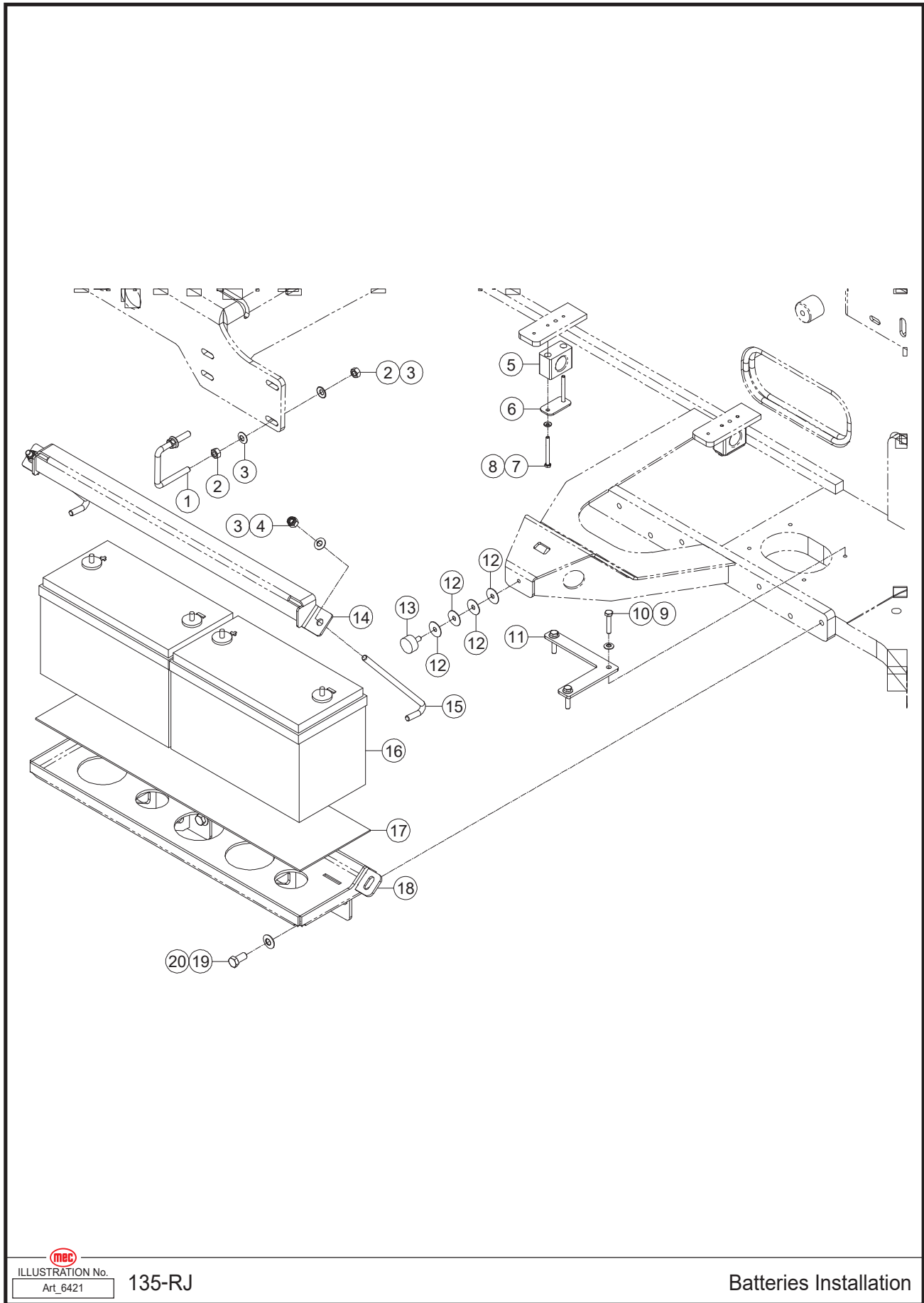



 ILLUSTRATION No. **135-RJ**
Art_6420

Emergency Pumps Installation

Item	Part Number	Description	Qty.
1	47753	Emergency Pump Assembly	2
--	47754	Motor	1
--	47755	Pump	1
2	60019	Screw HHCS M10-1.50 × 20 ZP	4
3	60444	Spring Washer	7
4	60450	Bracket	1
5	50033	Screw HHCS M10-1.50 × 25 ZP	3
6	47759	Check Valve	2
7	48401	Check Valve	2

Batteries Installation



 ILLUSTRATION No. 135-RJ
Art_6421

Batteries Installation

Item	Part Number	Description	Qty.
1	60461	U-Bolt	1
2	60089	Nut NHEX M10-1.50 ZP	4
3	60444	Spring Washer	6
4	60017	Nut NNYL M10-1.50 ZP	2
5	60188	Clamp	2
6	60819	Plate	2
7	60114	Screw HHCS M06-1.00 × 60 ZP	4
8	48186	Spring Washer	4
9	47750	Spring Washer	3
10	60133	Screw HHCS M08-1.25 × 40 ZP	3
11	60248	Terminal Strip	1
12	60480	Shim	4
13	49021	Rubber Mounting	1
14	60455	Retainer	1
15	60453	Hook, Battery Hold Down	2
16	43144	Battery	2
17	60454	Rubber Mounting	1
18	60456	Support	1
19	60032	Screw HHCS M12-1.75 × 25 ZP	6
20	60445	Spring Washer	6

Lower Control Box Installation

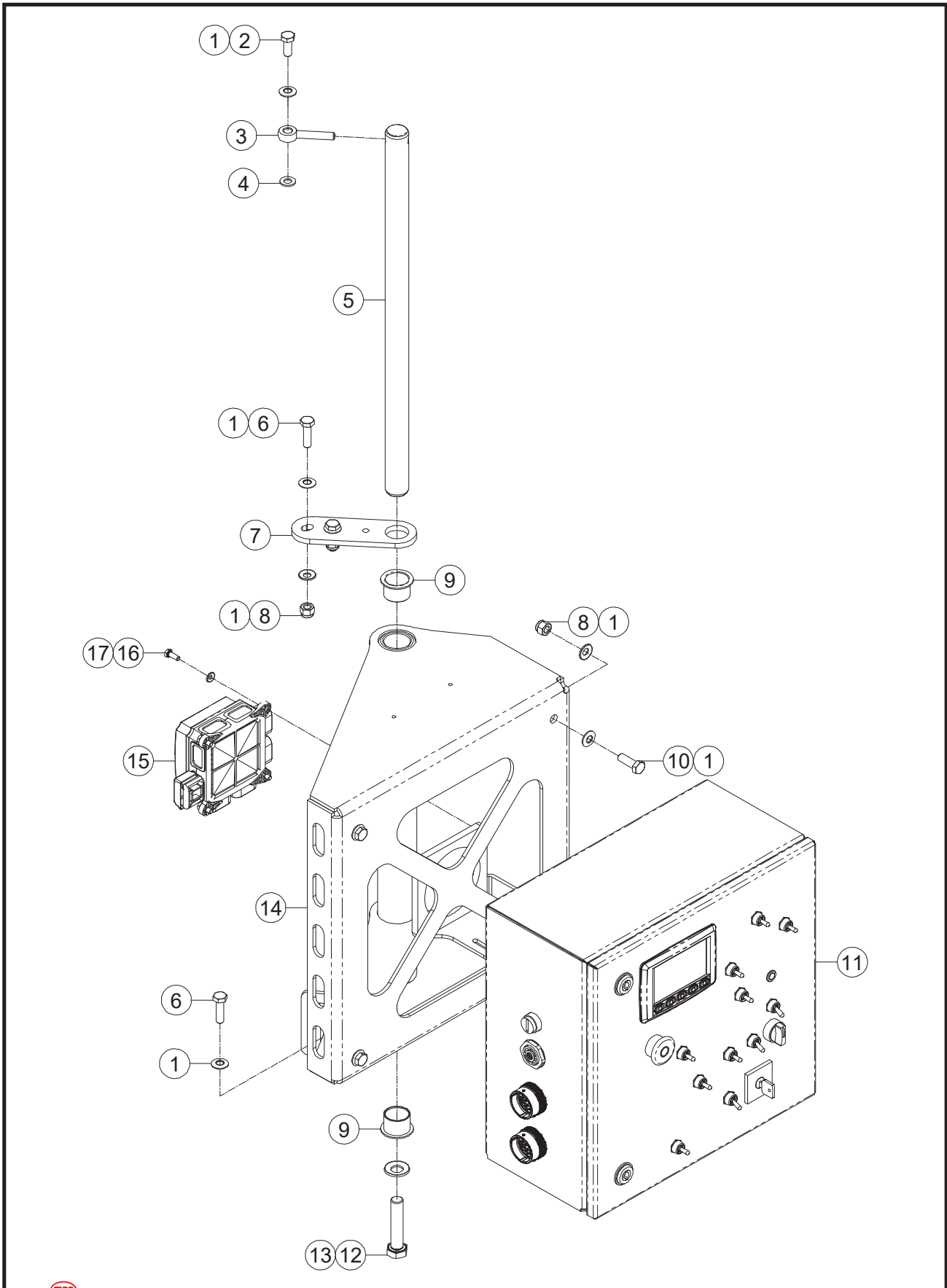

 ILLUSTRATION No. 135-RJ
Art_6422

Lower Control Box Installation

Item	Part Number	Description	Qty.
1	60444	Spring Washer	14
2	50033	Screw HHCS M10-1.50 × 25 ZP	1
3	43024	Pin, Lock	1
4	60012	WSHR M10 Standard Flat Washer ZP	1
5	60761	Pin	1
6	60022	Screw HHCS M10-1.50 × 35 ZP	3
7	60762	Plate	1
8	60017	Nut NNYL M10-1.50 ZP	6
9	48667	Sleeve Bearing	2
10	60021	Screw HHCS M10-1.50 × 30 ZP	4
11	REF	Ground Control Box Assembly (Refer to page 238)	1
12	60199	Screw HHCS M16-2.00 × 75 ZP	1
13	60840	Spring Washer	1
14	60600	Bracket	1
15	47701	Power Distribution Module (Refer to page 236)	1
16	50445	Screw HHCS M06-1.00 × 16 ZP	4
17	48186	Spring Washer	4

REF – Reference

Limit Switches Installation

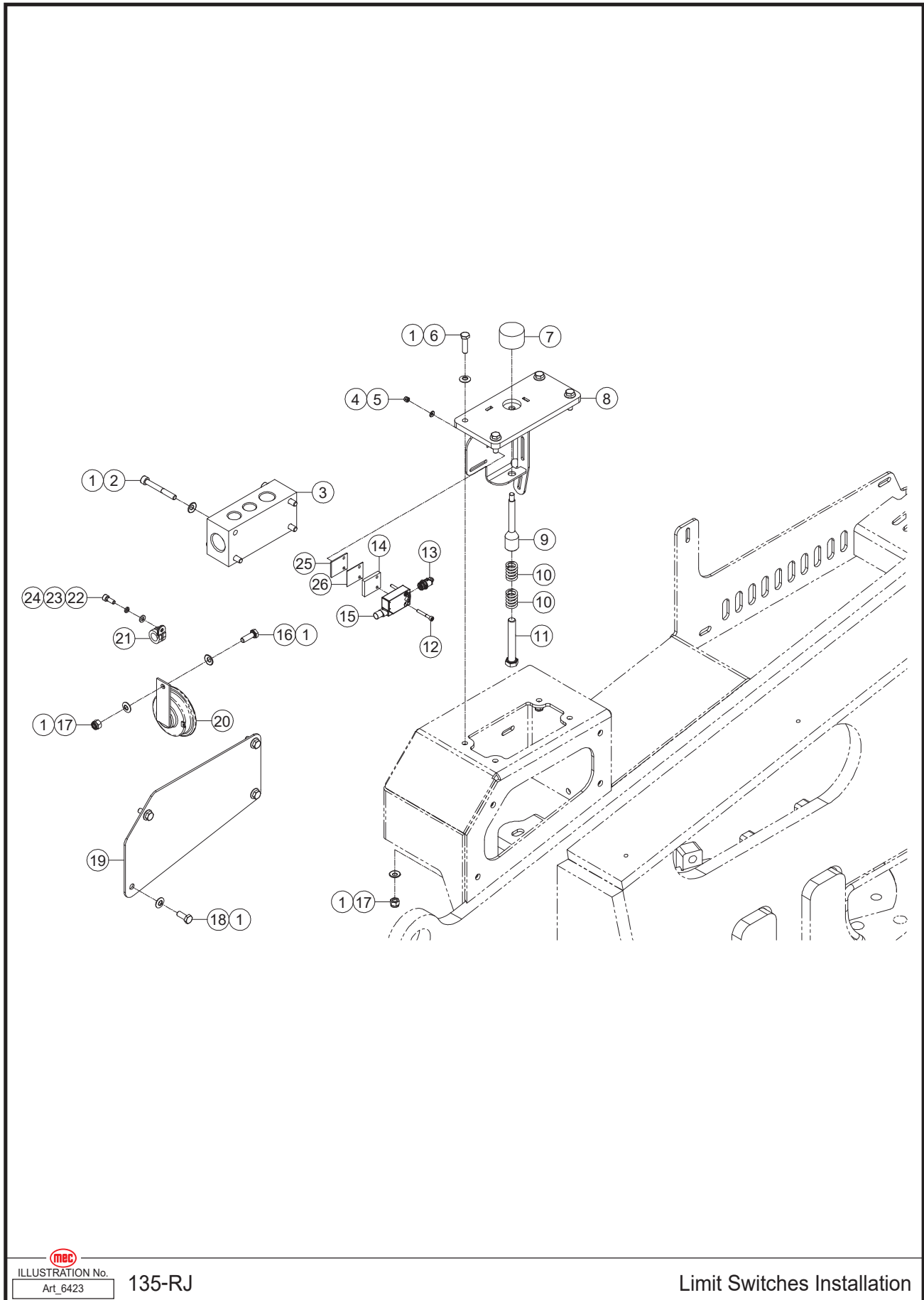

 ILLUSTRATION No. 135-RJ
Art_6423

Limit Switches Installation

Item	Part Number	Description	Qty.
1	47750	Spring Washer	18
2	60152	Screw SHCS M08-1.25 × 65 ZP	4
3	60104	Return Oil Block	1
4	60839	Spring Washer	2
5	60072	Nut NNYL M04-0.70 ZP	2
6	60044	Screw HHCS M08-1.25 × 30 ZP	4
7	47614	Rubber Mounting	1
8	60575	Bracket, Limit Switch	1
9	60756	Pin	1
10	60757	Spring	2
11	60126	Screw HHCS M12-1.75 × 80 ZP	1
12	50469	Screw SHCS M04-0.70 × 35 ZP	2
13	60621	Limit Switch Actuator	1
14	60754	Shim	1
15	60617	Limit Switch	1
16	60043	Screw HHCS M08-1.25 × 25 ZP	1
17	60070	Nut NNYL M08-1.25 ZP	5
18	50030	Screw HHCS M08-1.25 × 20 ZP	4
19	60798	Cover	1
20	43243	Horn	1
21	47583	Clamp	1
22	60041	Screw SHCS M06-1.00 × 16 ZP	1
23	53046	WSHR M06 Spring Washer ZP	1
24	60015	WSHR M06 Standard Flat Washer ZP	1
25	60546	Shim	1
26	60545	Shim	1

Hydraulic Cooling System Installation

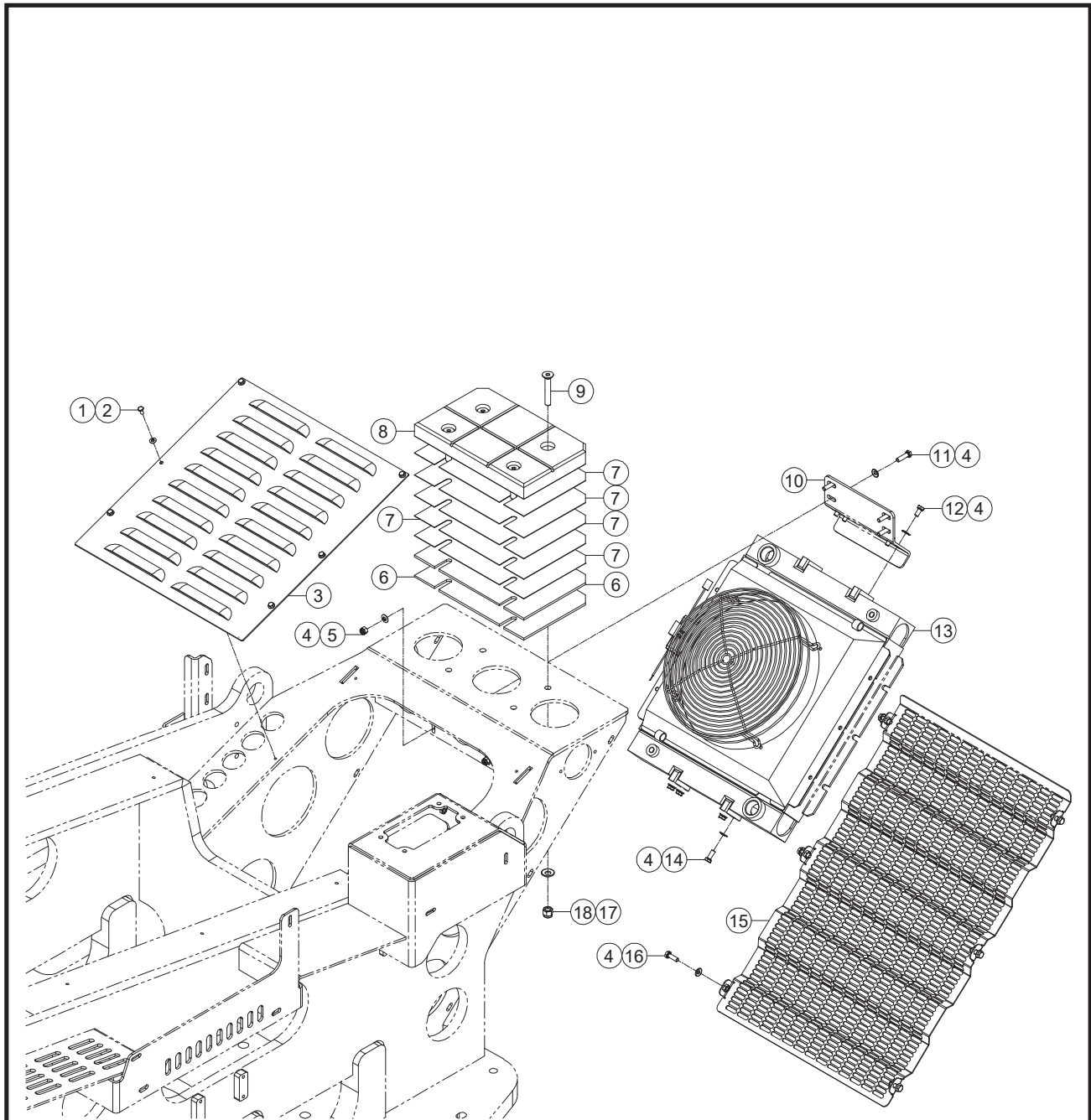



ILLUSTRATION No. 135-RJ
Art_6424

Hydraulic Cooling System Installation

Item	Part Number	Description	Qty.
1	48186	Spring Washer	6
2	60026	Screw HHCS M06-1.00 × 12 ZP	6
3	60469	Louver	1
4	47750	Spring Washer	22
5	60070	Nut NNYL M08-1.25 ZP	4
6	60823	Shim	2
7	60822	Shim	5
8	60821	Boom Pad	1
9	60211	Screw CSCS M12-1.75 × 75 ZP	4
10	60457	Support	1
11	60044	Screw HHCS M08-1.25 × 30 ZP	4
12	60063	Screw HHCS M08-1.25 × 16 ZP	4
13	60488	Hydraulic Cooling Assembly	1
14	50030	Screw HHCS M08-1.25 × 20 ZP	4
15	60510	Housing	1
16	60043	Screw HHCS M08-1.25 × 25 ZP	6
17	60445	Spring Washer	4
18	60074	Nut NNYL M12-1.75 ZP	4

Fuel Tank Installation

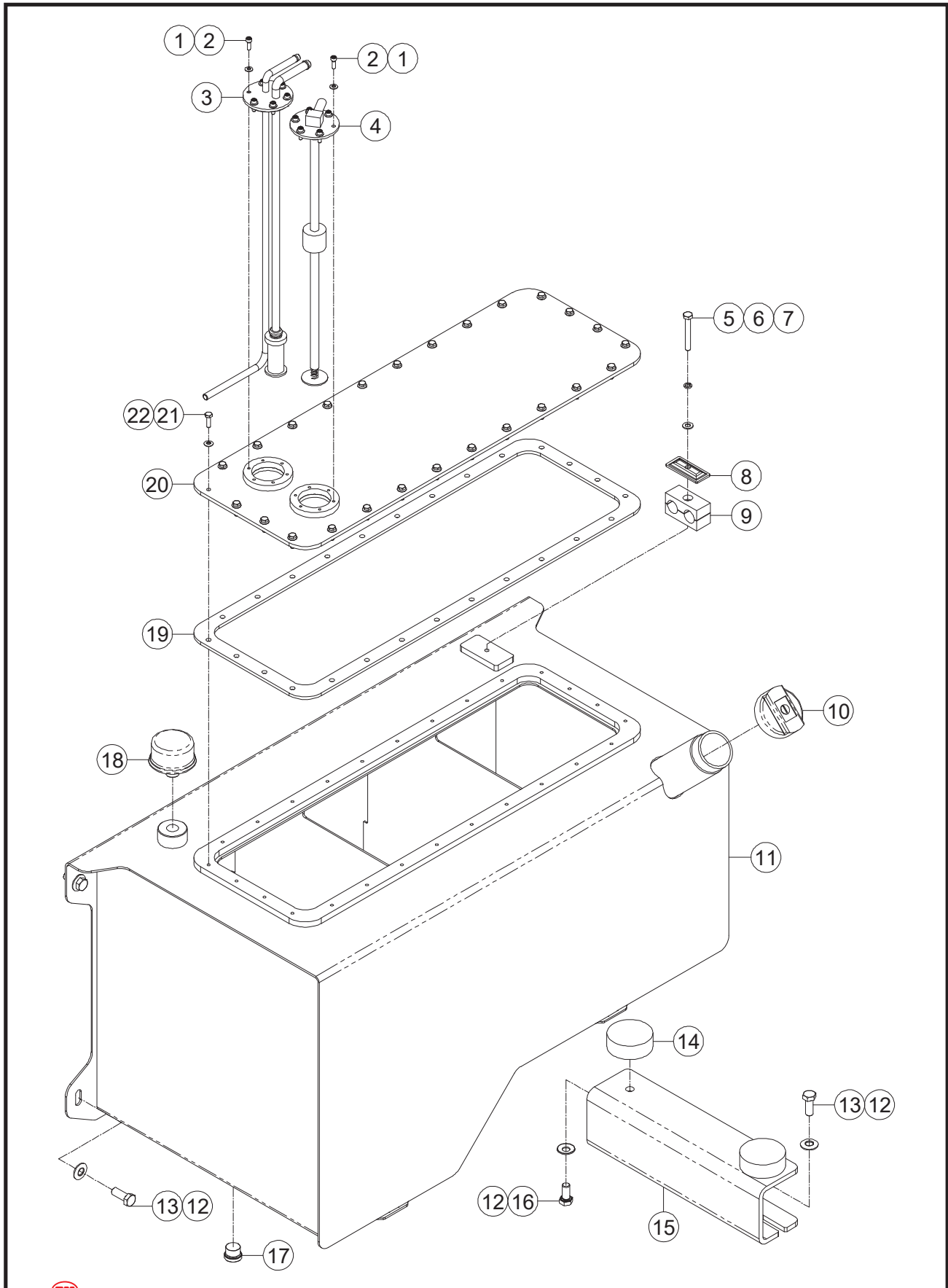

ILLUSTRATION No. Art_6425

135-RJ

Fuel Tank Installation

Item	Part Number	Description	Qty.
1	60443	Spring Washer	12
2	60073	Screw SHCS M05-0.80 × 16 ZP	12
3	47686	Suction Pipe	1
4	60201	Fuel Level Sensor	1
5	60088	Screw HHCS M08-1.25 × 60 ZP	1
6	60009	WSHR M08 Spring Washer ZP	1
7	60008	WSHR M08 Standard Flat Washer ZP	1
8	60411	Plate	1
9	46240	Clamp	1
10	47692	Plug	1
11	60565	Fuel Tank	1
12	60445	Spring Washer	8
13	60096	Screw HHCS M12-1.75 × 30 ZP	6
14	47689	Seal	2
15	60591	Support	1
16	60032	Screw HHCS M12-1.75 × 25 ZP	2
17	47693	Plug	1
18	47687	Filter	1
19	60464	Seal	1
20	60465	Cover	1
21	50028	Screw HHCS M06-1.00 × 20 ZP	26
22	48186	Spring Washer	26

Hydraulic Generator Assembly

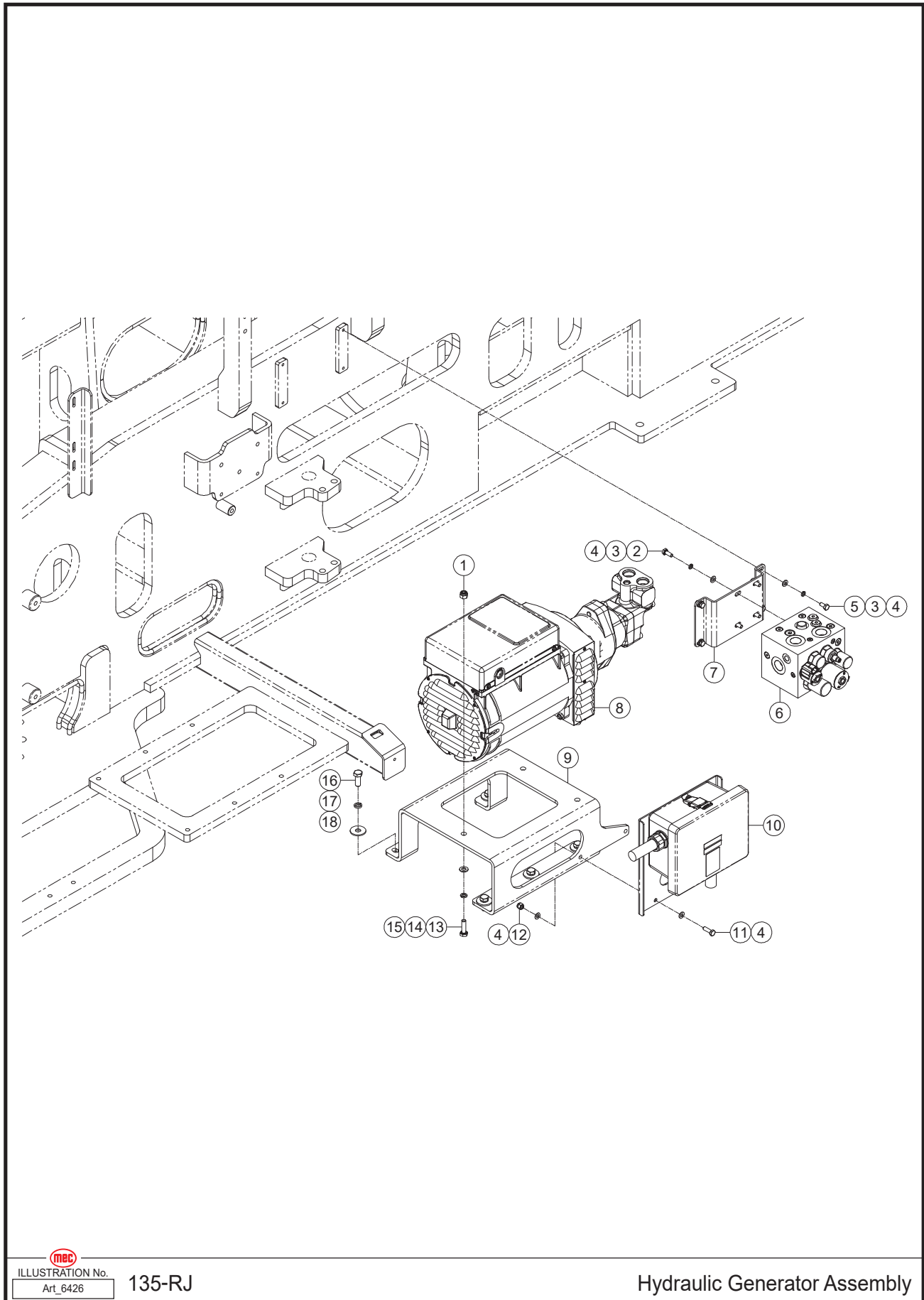

ILLUSTRATION No. 135-RJ
Art_6426

Hydraulic Generator Assembly

Item	Part Number	Description	Qty.
1	60017	Nut NNYL M10-1.50 ZP	3
2	50030	Screw HHCS M08-1.25 × 20 ZP	4
3	60009	WSHR M08 Spring Washer ZP	8
4	60008	WSHR M08 Standard Flat Washer ZP	12
5	60063	Screw HHCS M08-1.25 × 16 ZP	4
6	47734	Generator Manifold Assembly (Refer to page 100)	1
7	47733	Bracket	1
8	47729	Hydraulic Generator	1
9	49258	Bracket	1
10	49259	Breaker Box	1
11	60043	Screw HHCS M08-1.25 × 25 ZP	2
12	60070	Nut NNYL M08-1.25 ZP	2
13	60022	Screw HHCS M10-1.50 × 35 ZP	3
14	60020	WSHR M10 Spring Washer ZP	3
15	60012	WSHR M10 Standard Flat Washer ZP	3
16	60096	Screw HHCS M12-1.75 × 30 ZP	5
17	53148	WSHR M12 Spring Washer ZP	5
18	53478	WSHR M12 Flat Fender Washer ZP	5

Generator Manifold Assembly

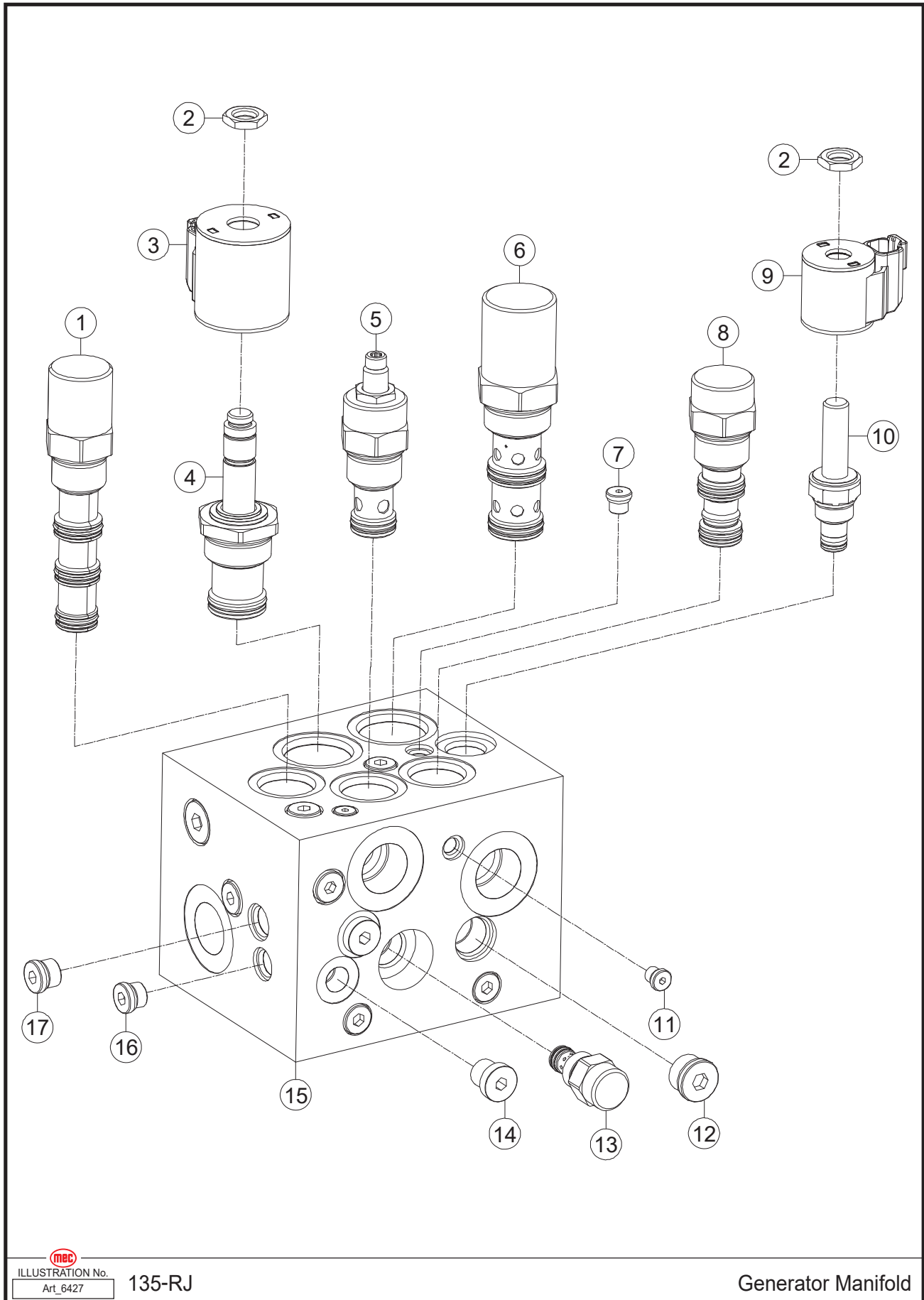

 ILLUSTRATION No. 135-RJ
Art_6427

Generator Manifold

Item	Part Number	Description	Qty.
1	47735	Cartridge, Flow Control Valve	1
2	42795	Nut	2
3	47736	Coil	1
4	47737	Cartridge, Proportional Solenoid Valve	1
5	47738	Cartridge, Flow Control Valve	1
6	47739	Cartridge, Flow Control Valve	1
7	43643	Plug	1
8	47740	Cartridge, Logic Valve	1
9	47741	Coil	1
10	43372	Cartridge, Solenoid Valve	1
11	43465	Plug	5
12	43417	Plug	4
13	47742	Cartridge, Flow Control Valve	1
14	46869	Plug	2
15	47743	Body	1
16	42802	Plug	5
17	43434	Plug	4

Engine ECU Installation

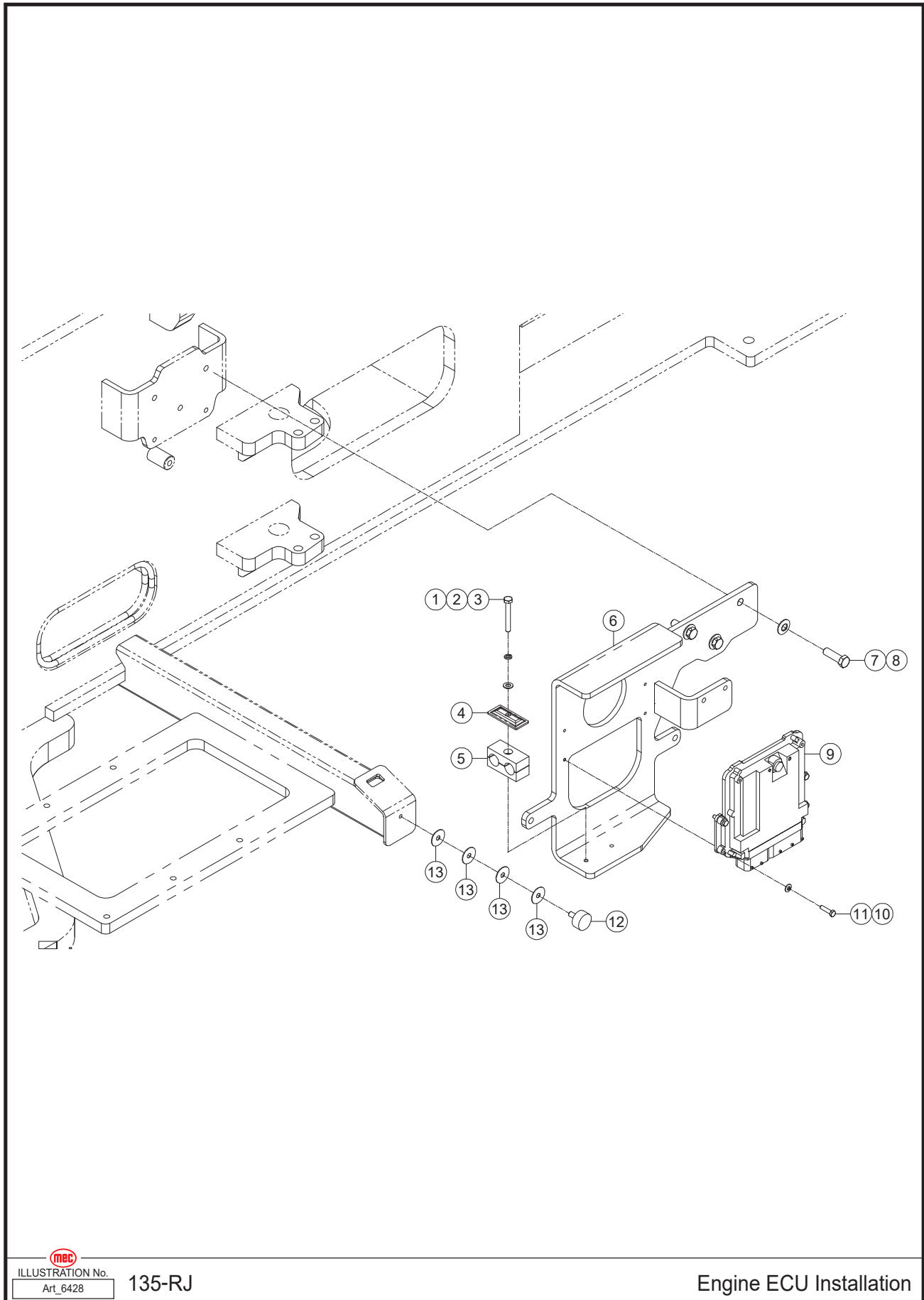
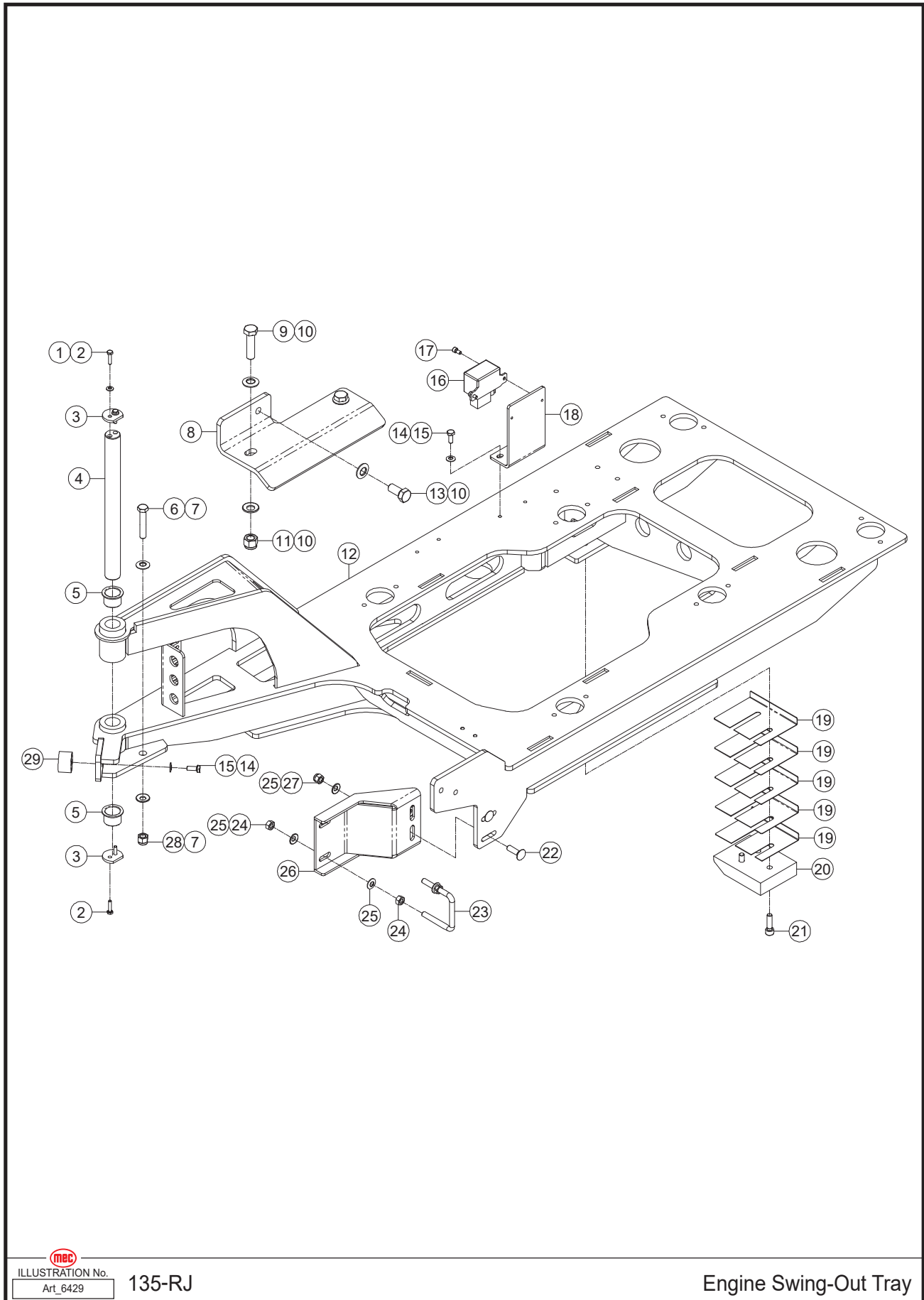



 ILLUSTRATION No. 135-RJ
Art_6428

Engine ECU Installation

Item	Part Number	Description	Qty.
1	60008	WSHR M08 Standard Flat Washer ZP	1
2	60009	WSHR M08 Spring Washer ZP	1
3	60088	Screw HHCS M08-1.25 × 60 ZP	1
4	60411	Plate	1
5	46240	Clamp	1
6	60584	Bracket	1
7	60060	Screw HHCS M12-1.75 × 40 ZP	3
8	60445	Spring Washer	3
9	47694	Engine ECU	1
10	48186	Spring Washer	4
11	60014	Screw HHCS M06-1.00 × 25 ZP	4
12	49021	Rubber Mounting	1
13	60480	Shim	4

Engine Swing-Out Tray

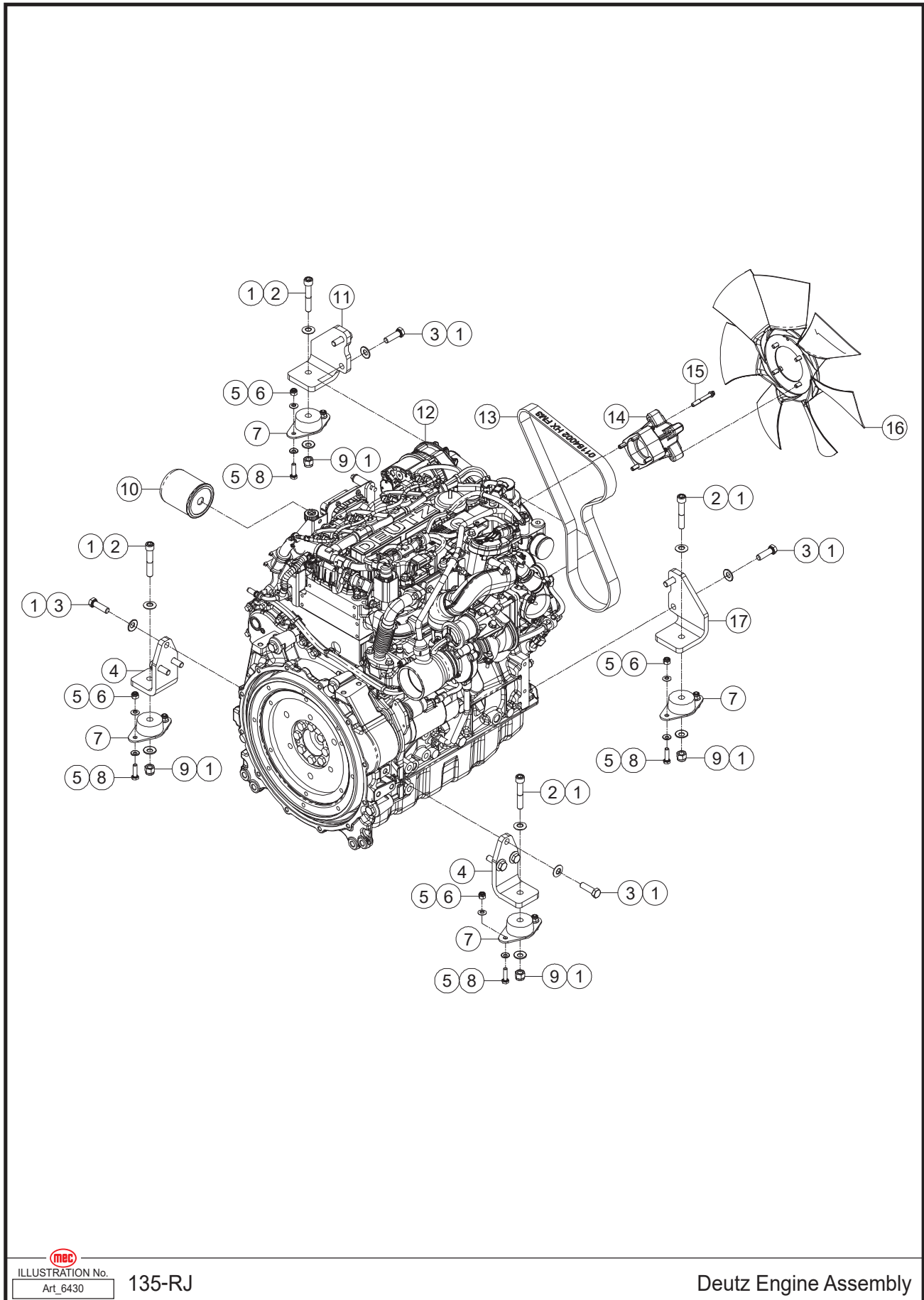



 ILLUSTRATION No. 135-RJ
Art_6429

Engine Swing-Out Tray

Item	Part Number	Description	Qty.
1	48186	Spring Washer	6
2	60014	Screw HHCS M06-1.00 × 25 ZP	4
3	48187	Cover	2
4	48188	Pin	1
5	48667	Sleeve Bearing	2
6	60149	Screw HHCS M12-1.75 × 65 ZP	1
7	60445	Spring Washer	2
8	60794	Bracket	1
9	60056	Screw HHCS M16-2.00 × 60 ZP	2
10	60840	Spring Washer	5
11	60077	Nut NNYL M16-2.00 ZP	2
12	60578	Engine Support	1
13	60208	Screw HHCS M16-2.00 × 35 ZP	1
14	47750	Spring Washer	3
15	50030	Screw HHCS M08-1.25 × 20 ZP	3
16	47610	Contact, Preheat	1
17	53380	Screw SHCS M06-1.00 × 12 ZP	2
18	60515	Bracket	1
19	60793	Shim	5
20	60792	Sliding Block	1
21	60109	Screw SHCS M10-1.50 × 35 ZP	3
22	53558	Square Neck Carriage Bolt M10-1.50 × 35 ZP	2
23	60461	U-Bolt	1
24	60089	Nut NHEX M10-1.50 ZP	4
25	60444	Spring Washer	6
26	60462	Bracket	1
27	60017	Nut NNYL M10-1.50 ZP	2
28	60074	Nut NNYL M12-1.75 ZP	1
29	47614	Rubber Mounting	1

Deutz Engine Assembly

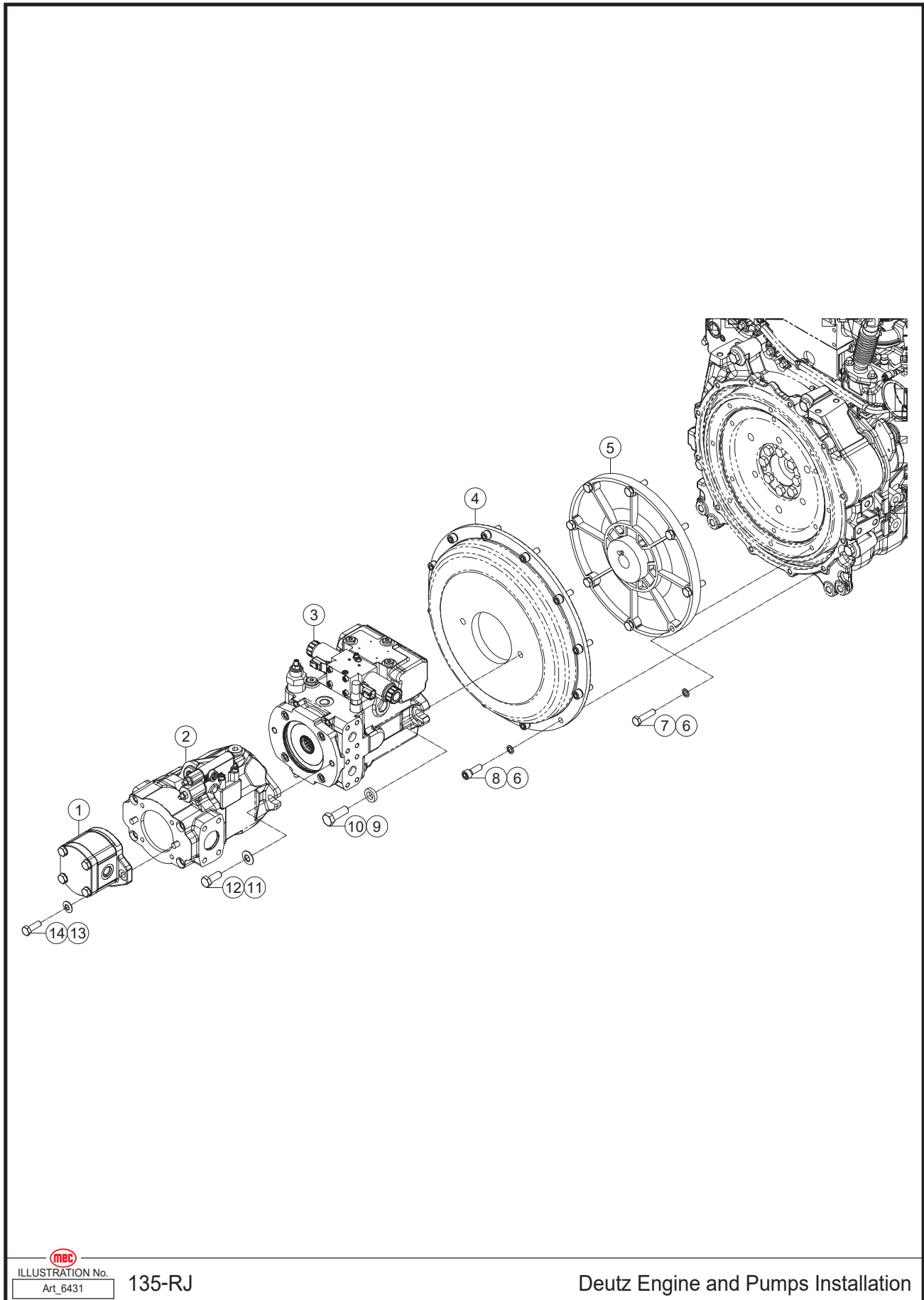



 ILLUSTRATION No. 135-RJ
Art_6430

Deutz Engine Assembly

Item	Part Number	Description	Qty.
1	60445	Spring Washer	18
2	60179	Screw SHCS M12-1.75 × 70 ZP	4
3	60060	Screw HHCS M12-1.75 × 40 ZP	10
4	48192	Support	2
5	47750	Spring Washer	16
6	60070	Nut NNYL M08-1.25 ZP	8
7	47620	Rubber Mounting	4
8	60044	Screw HHCS M08-1.25 × 30 ZP	8
9	60074	Nut NNYL M12-1.75 ZP	4
10	47623	Filter Cartridge	1
11	48193	Support	1
12	47624	Engine	1
13	47618	V-Belt	1
14	47617	Adapter	1
15	47616	Screw	4
16	47615	Fan	1
17	48191	Support	1

Deutz Engine and Pumps Installation

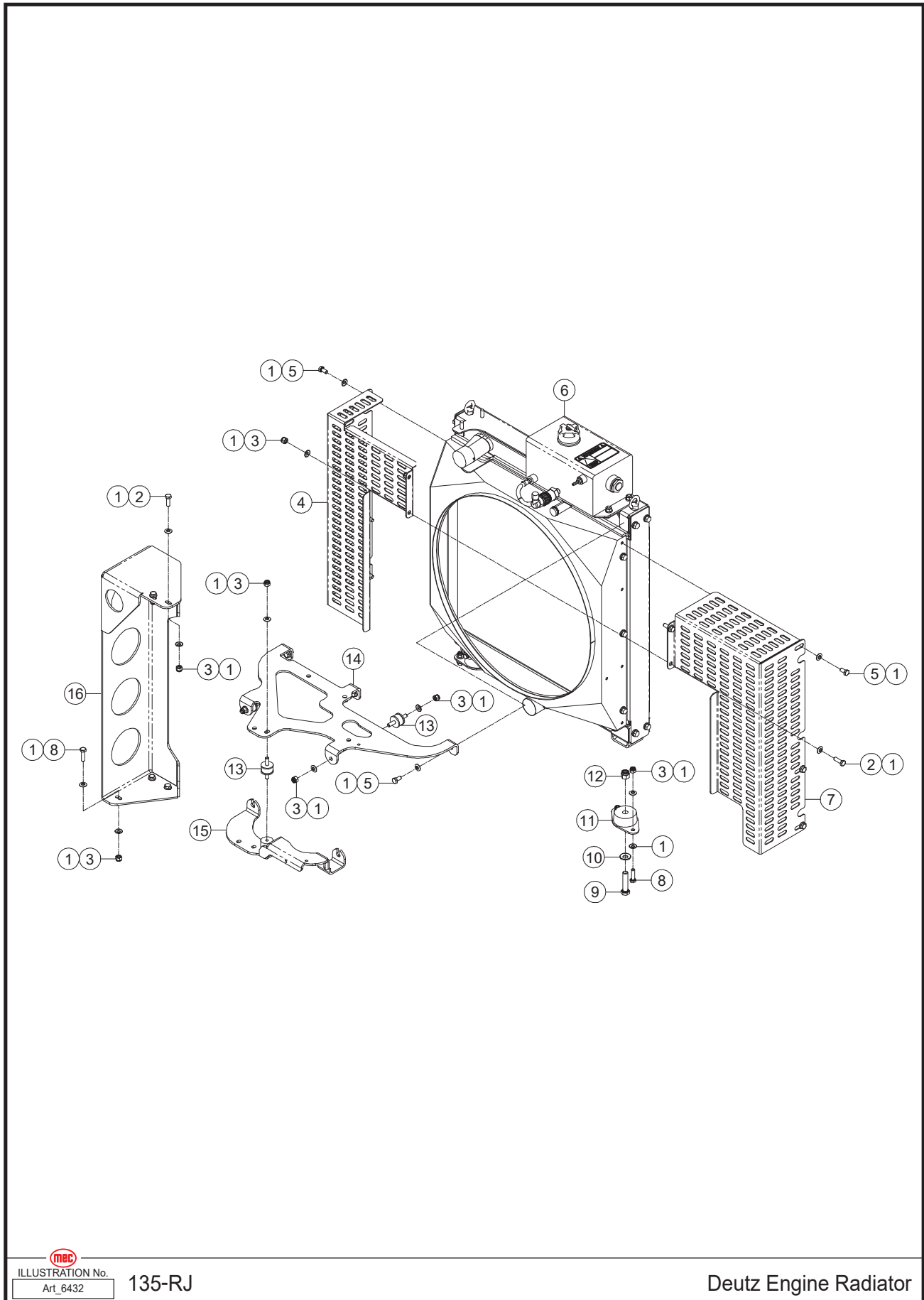



 ILLUSTRATION No. 135-RJ
Art_6431

Deutz Engine and Pumps Installation

Item	Part Number	Description	Qty.
1	60560	Gear Pump Assembly	1
2	60559	Function Pump Assembly	1
3	60558	Drive Pump Assembly	1
4	60502	Protection	1
5	60568	Flange	1
6	60842	Spring Washer	20
7	60053	Screw HHCS M10-1.50 × 40 ZP	8
8	60061	Screw SHCS M10-1.50 × 30 ZP	12
9	48689	Washer	2
10	60141	Screw HHCS M14-2.00 × 40 ZP	2
11	60445	Spring Washer	2
12	60096	Screw HHCS M12-1.75 × 30 ZP	2
13	60444	Spring Washer	2
14	60021	Screw HHCS M10-1.50 × 30 ZP	2

Deutz Engine Radiator, Part 1

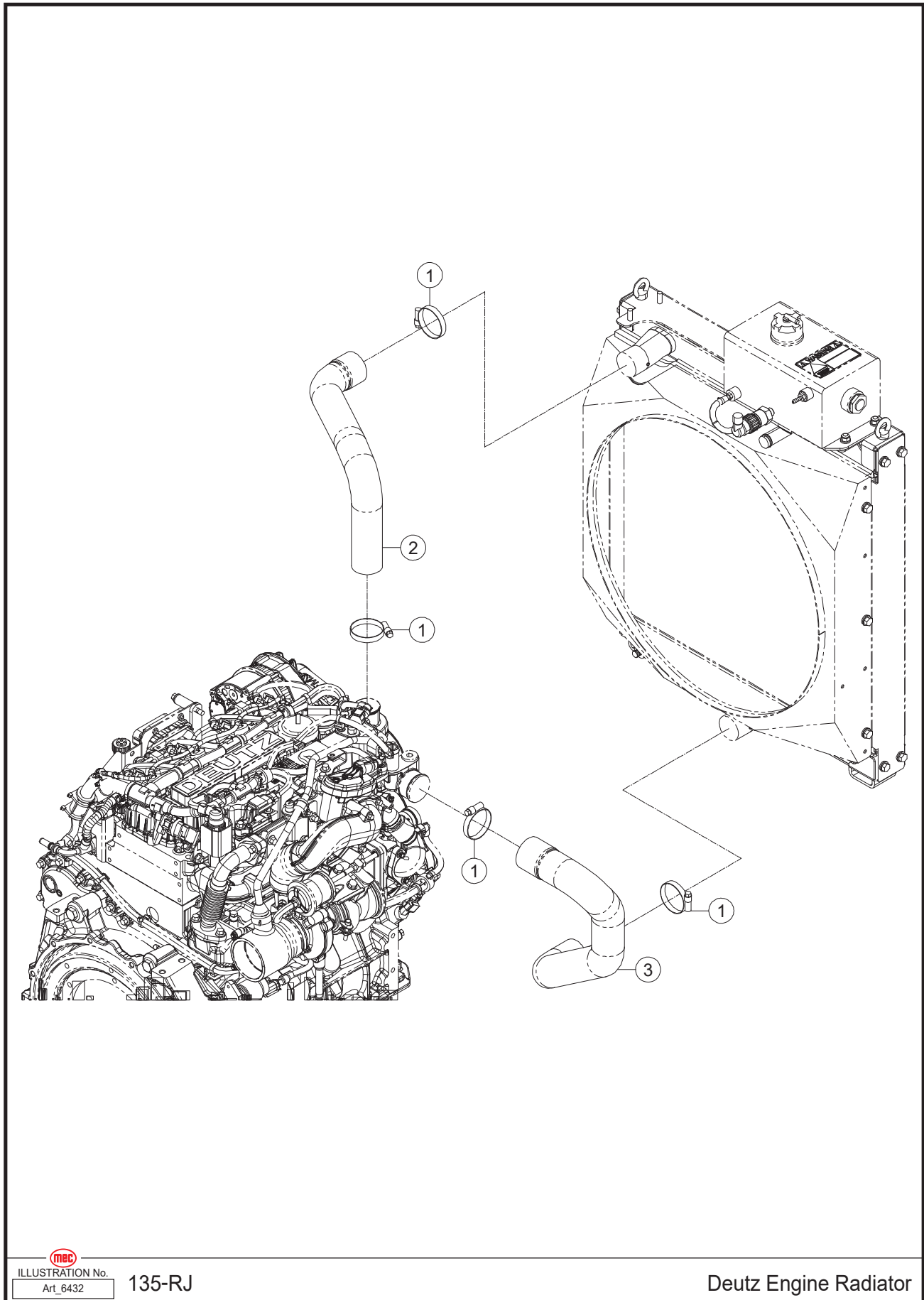



ILLUSTRATION No. 135-RJ
Art_6432

Deutz Engine Radiator

Item	Part Number	Description	Qty.
1	47750	Spring Washer	36
2	60043	Screw HHCS M08-1.25 × 25 ZP	4
3	60070	Nut NNYL M08-1.25 ZP	16
4	60507	Housing	1
5	60063	Screw HHCS M08-1.25 × 16 ZP	9
6	60590	Radiator	1
7	60506	Housing	1
8	60044	Screw HHCS M08-1.25 × 30 ZP	7
9	60142	Screw HHCS M12-1.75 × 55 ZP	2
10	60445	Spring Washer	2
11	60512	Rubber Mounting	2
12	60074	Nut NNYL M12-1.75 ZP	2
13	60460	Rubber Mounting	3
14	60458	Bracket	1
15	60459	Bracket	1
16	60772	Bracket	1

Deutz Engine Radiator, Part 2

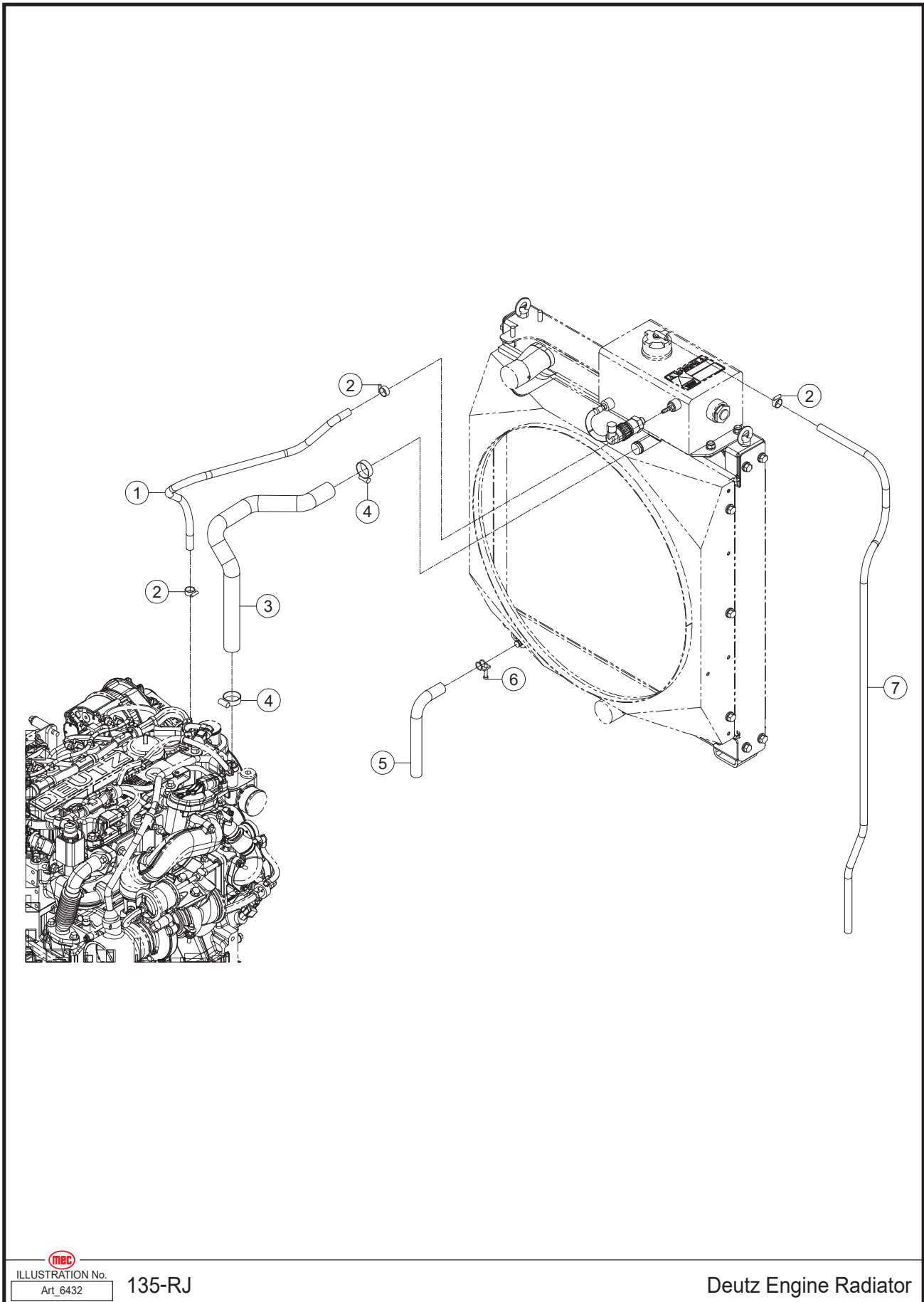



 ILLUSTRATION No. 135-RJ
Art_6432

Deutz Engine Radiator

Item	Part Number	Description	Qty.
1	47630	Clamp	4
2	60767	Upper Radiator Hose	1
3	60766	Lower Radiator Hose	1

Deutz Engine Radiator, Part 3

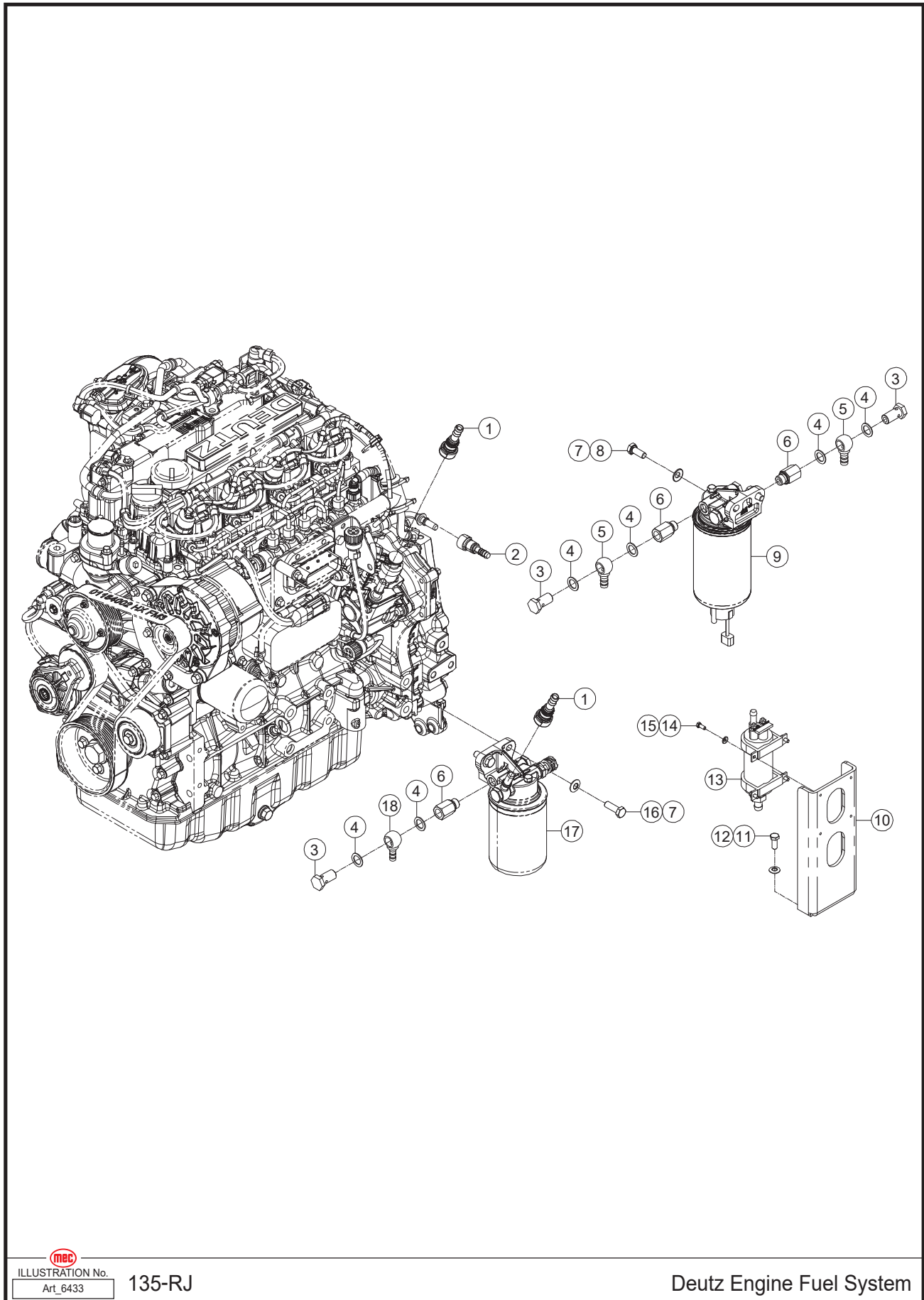



ILLUSTRATION No. 135-RJ
Art_6432

Deutz Engine Radiator

Item	Part Number	Description	Qty.
1	60769	Thin Hose, Engine to Radiator	1
2	47632	Clamp	3
3	60768	Thick Hose, Engine to Radiator	1
4	47637	Clamp	2
5	60489	Lower Radiator Hose, Short	1
6	47659	Clamp	1
7	60796	Thin Hose, Long	1

Deutz Engine Fuel System, Part 1

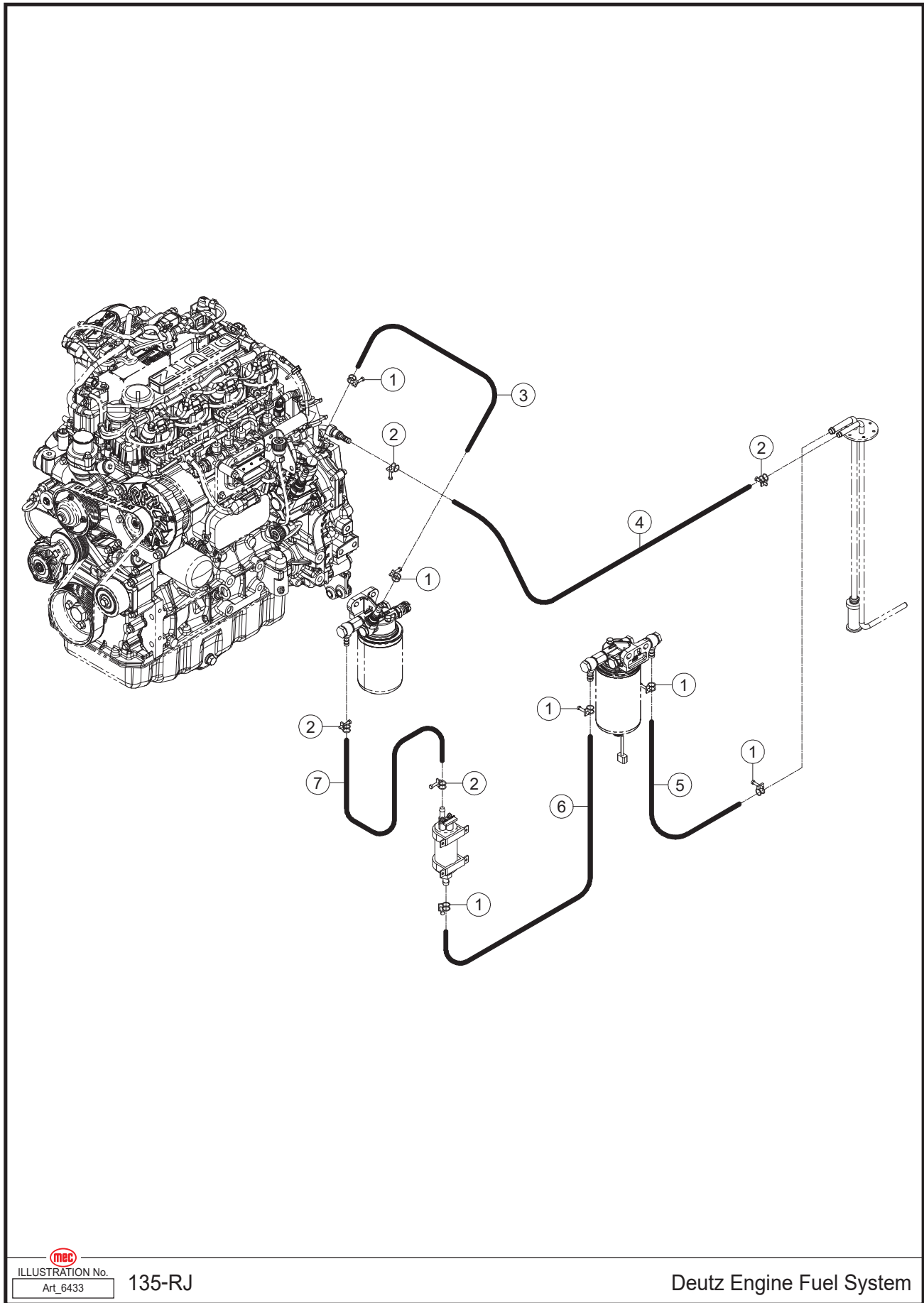



 ILLUSTRATION No. 135-RJ
Art_6433

Deutz Engine Fuel System

Item	Part Number	Description	Qty.
1	47644	Pipe Fitting	2
2	60484	Pipe Fitting	1
3	47653	Drilled Screw	3
4	47651	Washer	6
5	47652	Pipe Fitting	2
6	47650	Fitting	3
7	60444	Spring Washer	4
8	50033	Screw HHCS M10-1.50 × 25 ZP	2
9	47647	Fuel Filter	1
--	47648	Filter Cartridge	1
--	47649	Fuel Sensor	1
10	47655	Bracket	1
11	50030	Screw HHCS M08-1.25 × 20 ZP	2
12	47750	Spring Washer	2
13	47654	Fuel Pump	1
14	60111	Screw HHCS M05-0.80 × 12 ZP	4
15	60443	Spring Washer	4
16	60021	Screw HHCS M10-1.50 × 30 ZP	2
17	47656	Fuel Filter	1
--	47657	Filter Cartridge	1
18	47658	Pipe Fitting	1

Deutz Engine Fuel System, Part 2



 ILLUSTRATION No. 135-RJ
Art_6433

Deutz Engine Fuel System

Item	Part Number	Description	Qty.
1	47659	Clamp	6
2	47661	Clamp	4
3	60594	Hose, Engine to Fuel Filter	1
4	60593	Hose, Suction Pipe to Engine	1
5	60596	Hose, Suction Pipe to Fuel-Water Filter	1
6	60595	Hose, Fuel Pump to Fuel-Water Filter	1
7	60592	Hose Fuel Filter to Fuel Pump	1

Deutz Engine Air Filter

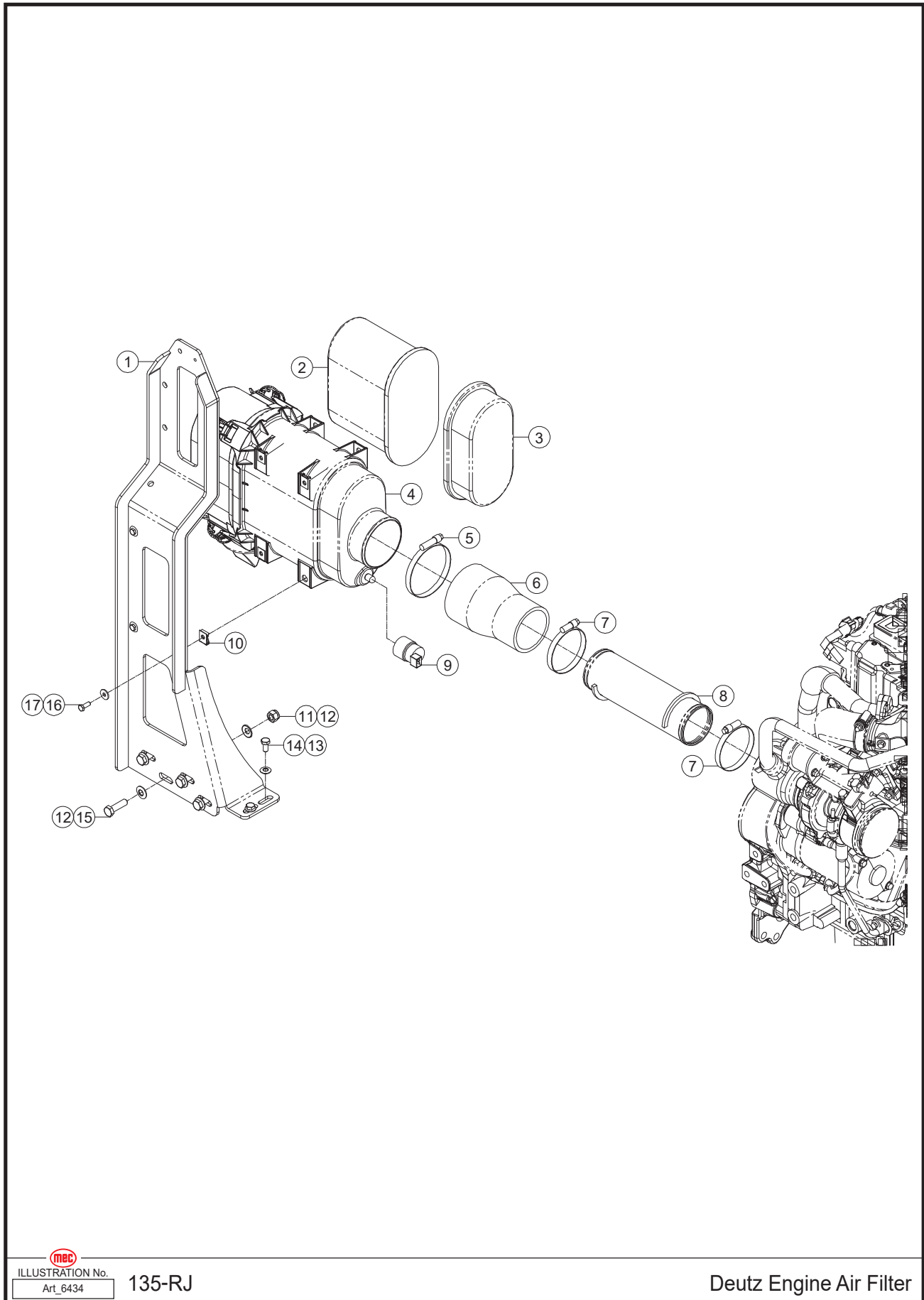
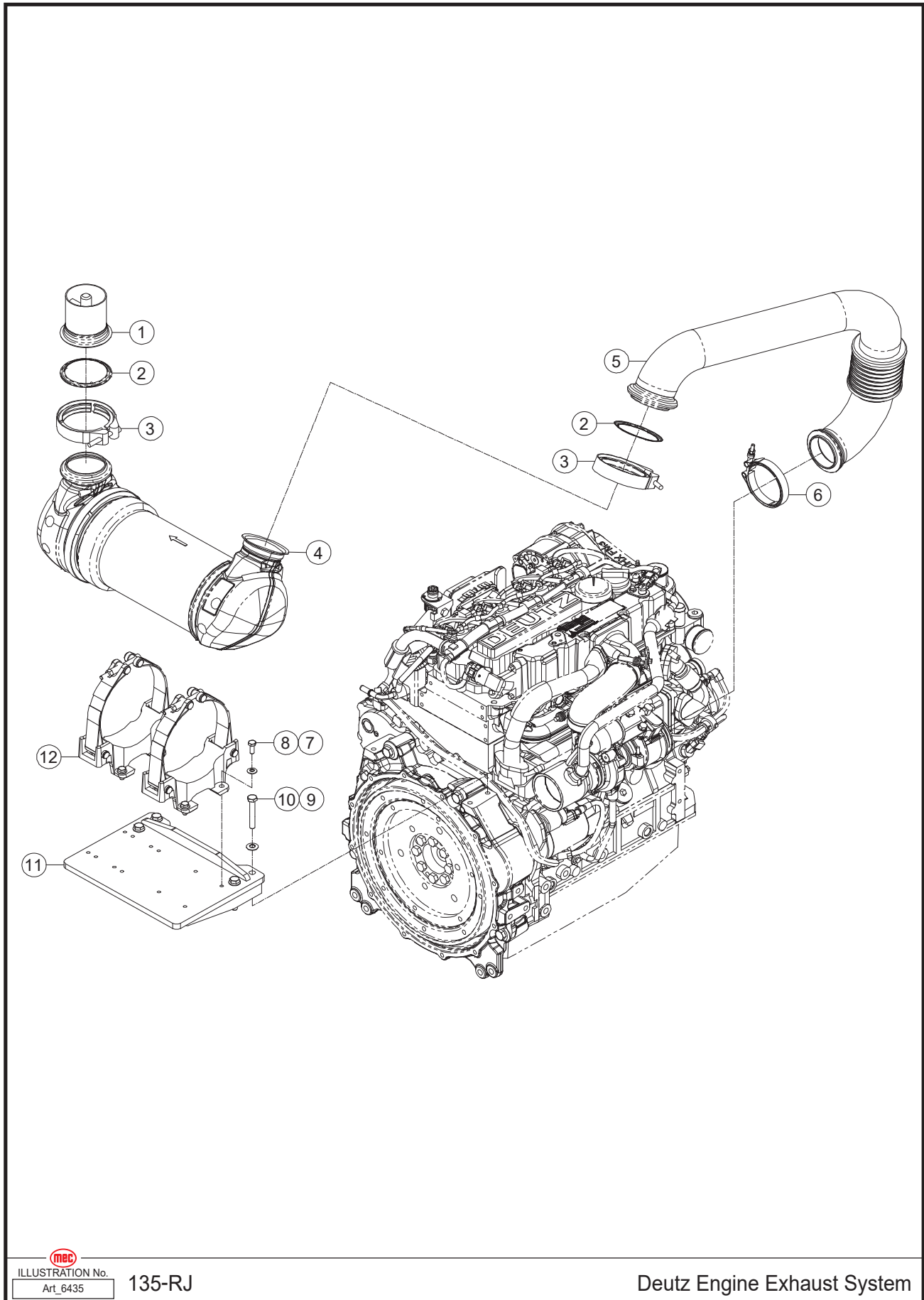



 ILLUSTRATION No. 135-RJ
Art_6434

Deutz Engine Air Filter

Item	Part Number	Description	Qty.
1	60538	Bracket	1
2	47670	Filter Cartridge	1
3	47669	Safety Cartridge	1
4	47674	Complete Air Filter	1
5	47671	Clamp	1
6	47668	Hose	1
7	47666	Clamp	2
8	60508	Connecting Pipe	1
9	47673	Air Filter Sensor	1
10	53481	No-Slip Clip-On Barrel Nut M06-1.00 ZP	4
11	60017	Nut NNYL M10-1.50 ZP	4
12	60444	Spring Washer	8
13	47750	Spring Washer	2
14	60063	Screw HHCS M08-1.25 × 16 ZP	2
15	60022	Screw HHCS M10-1.50 × 35 ZP	4
16	50445	Screw HHCS M06-1.00 × 16 ZP	4
17	50068	WSHR M06 Flat Fender Washer ZP	4

Deutz Engine Exhaust System

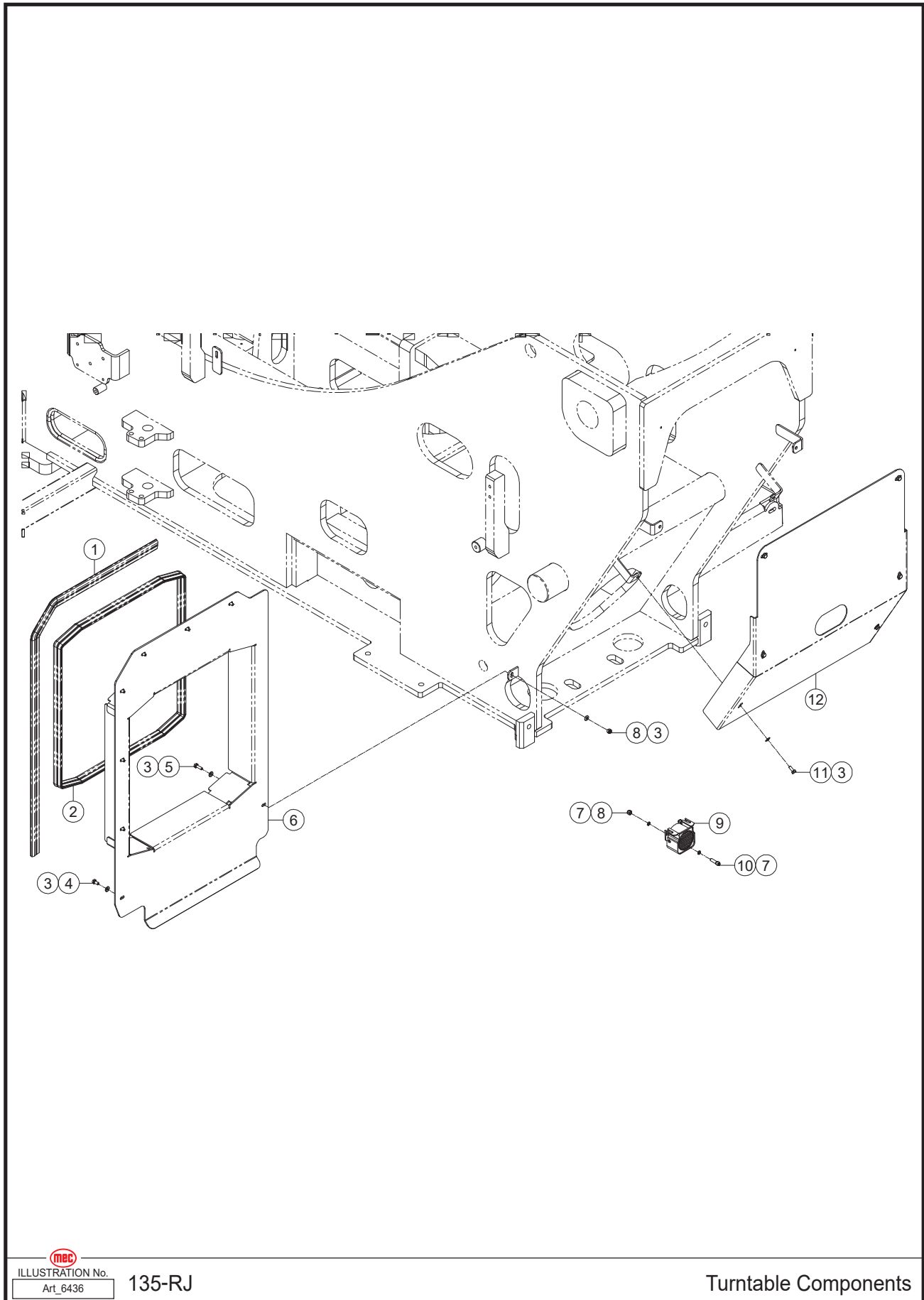



 ILLUSTRATION No. 135-RJ
Art_6435

Deutz Engine Exhaust System

Item	Part Number	Description	Qty.
1	47675	Connecting Pipe	1
2	47676	Seal	2
3	47677	Collar	2
4	47682	Catalyst	1
5	60516	Connecting Pipe	1
6	47679	Collar	1
7	47750	Spring Washer	8
8	50030	Screw HHCS M08-1.25 × 20 ZP	8
9	60444	Spring Washer	4
10	53577	Screw HHCS M10-1.50 × 50 ZP	4
11	60518	Support	1
12	47681	Support	1

Turntable Components



 ILLUSTRATION No. 135-RJ
Art_6436

Turntable Components

Item	Part Number	Description	Qty.
1	60598	Seal	1
2	60599	Seal	1
3	47750	Spring Washer	15
4	60063	Screw HHCS M08-1.25 × 16 ZP	7
5	60043	Screw HHCS M08-1.25 × 25 ZP	1
6	60597	Baffle	1
7	60841	Spring Washer	4
8	60070	Nut NNYL M08-1.25 ZP	3
9	42882	Alarm	1
10	53385	Screw SHCS M08-1.25 × 30 ZP	2
11	50030	Screw HHCS M08-1.25 × 20 ZP	6
12	60785	Cover	1

Counterweight Installation

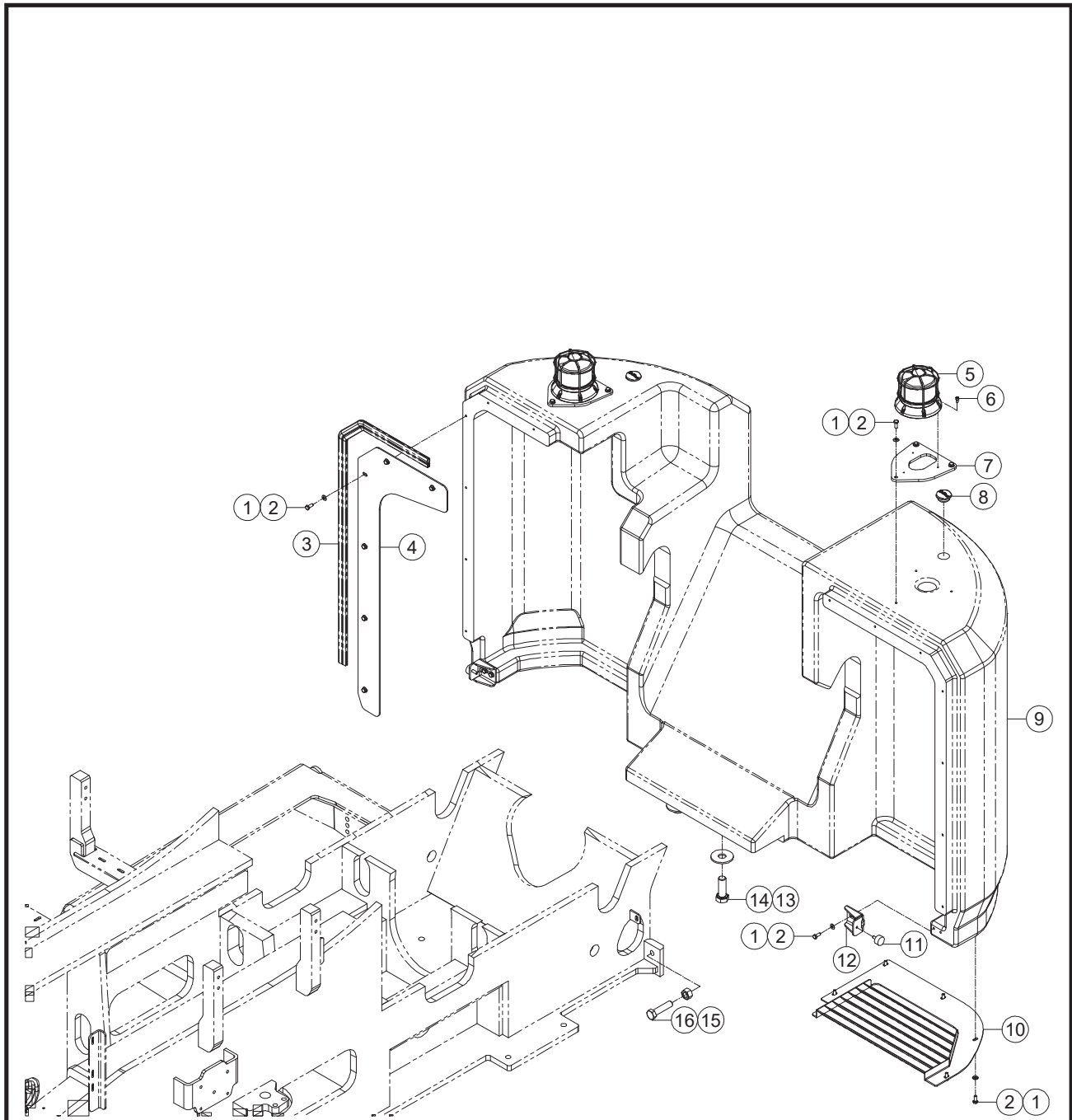



ILLUSTRATION No. 135-RJ
Art_6437

Counterweight Installation

Item	Part Number	Description	Qty.
1	47750	Spring Washer	21
2	50030	Screw HHCS M08-1.25 × 20 ZP	21
3	60606	Seal	1
4	60809	Housing	1
5	43060	Beacon	2
6	53380	Screw SHCS M06-1.00 × 12 ZP	6
7	60808	Plate	2
8	46735	Plug	2
9	49260	Counterweight	1
10	60511	Baffle	1
11	49021	Rubber Mounting	2
12	60771	Bracket	2
13	60066	WSHR M24 Flat Fender Washer ZP	2
14	60224	Screw HHCS M24-3.00 × 70 ZP	2
15	53526	Nut NHEX M20-2.50 ZP	2
16	60150	Screw HHCS M20-2.50 × 80 ZP	2

Turntable Covers

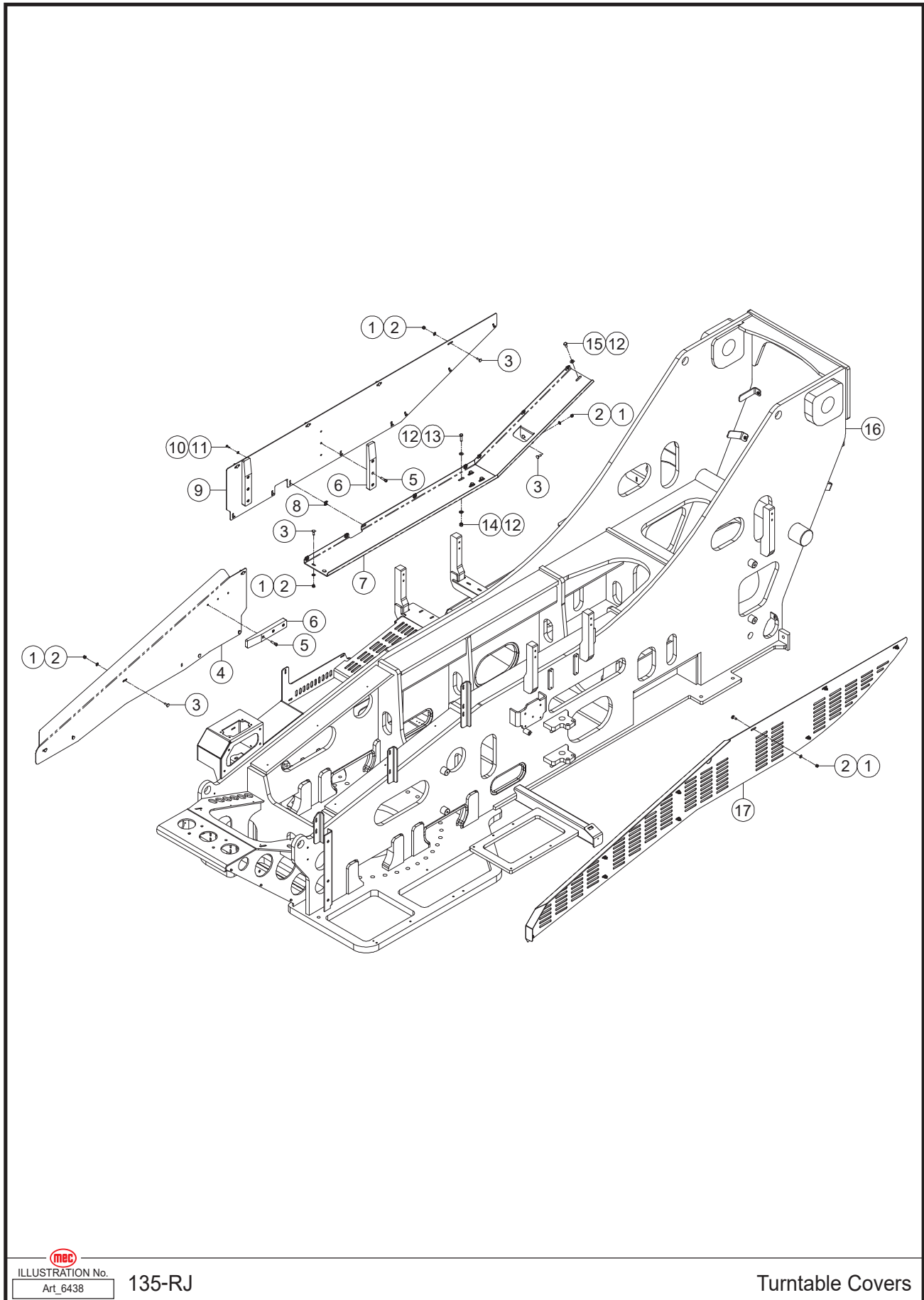
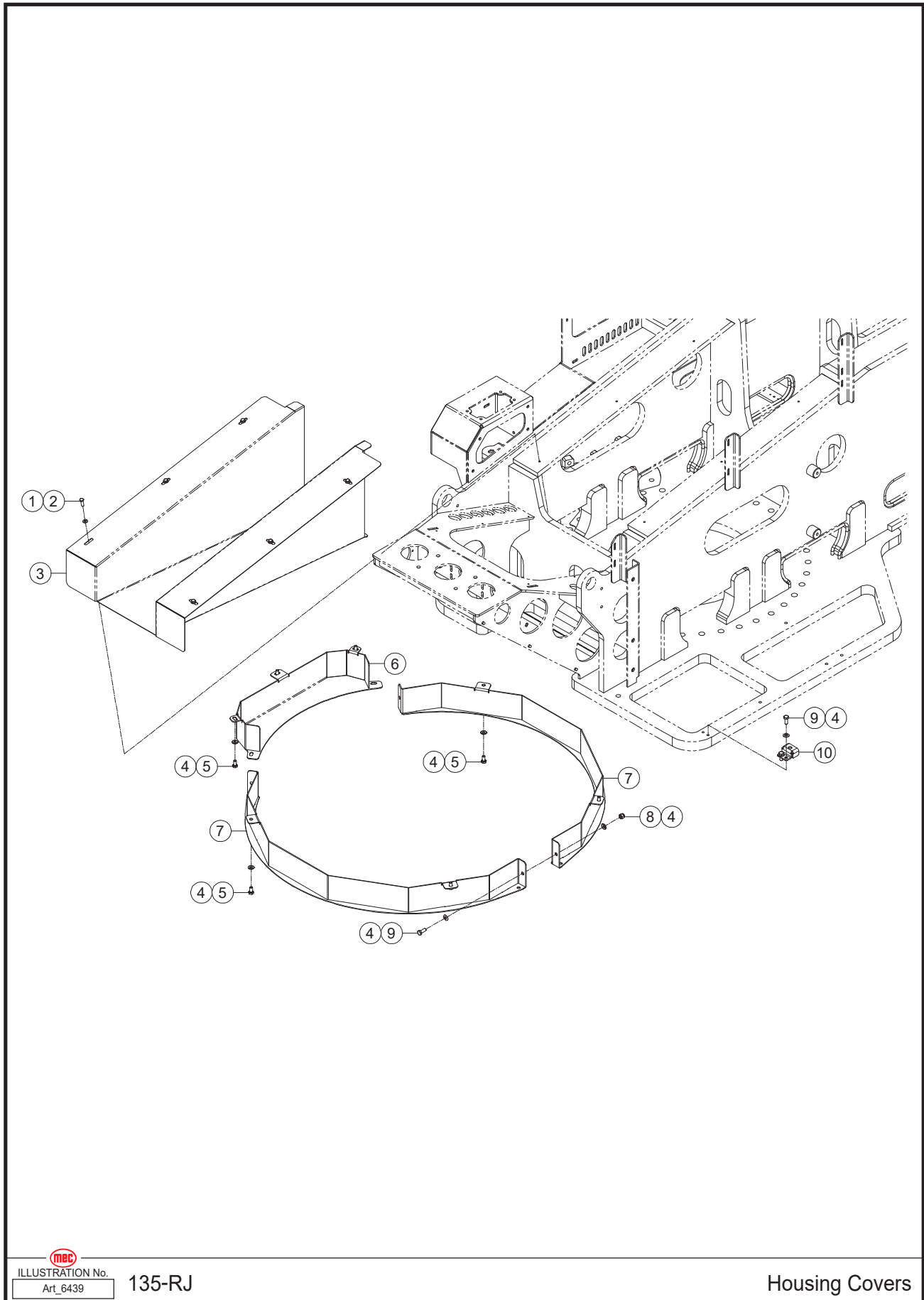



 ILLUSTRATION No. **135-RJ**
Art_6438

Turntable Covers

Item	Part Number	Description	Qty.
1	47750	Spring Washer	33
2	60070	Nut NNYL M08-1.25 ZP	33
3	60212	Square Neck Carriage Bolt M08-1.25 × 25 ZP	24
4	60800	Cover	1
5	53386	Screw SHCS M08-1.25 × 35 ZP	9
6	60466	Guide Plate	3
7	49261	Cover	1
8	53481	No-Slip Clip-On Barrel Nut M06-1.00 ZP	8
9	49262	Cover	1
10	48186	Spring Washer	8
11	50445	Screw HHCS M06-1.00 × 16 ZP	8
12	60444	Spring Washer	9
13	60022	Screw HHCS M10-1.50 × 35 ZP	4
14	60017	Nut NNYL M10-1.50 ZP	4
15	60019	Screw HHCS M10-1.50 × 20 ZP	1
16	49263	Turntable	1
17	60799	Cover	1

Housing Covers

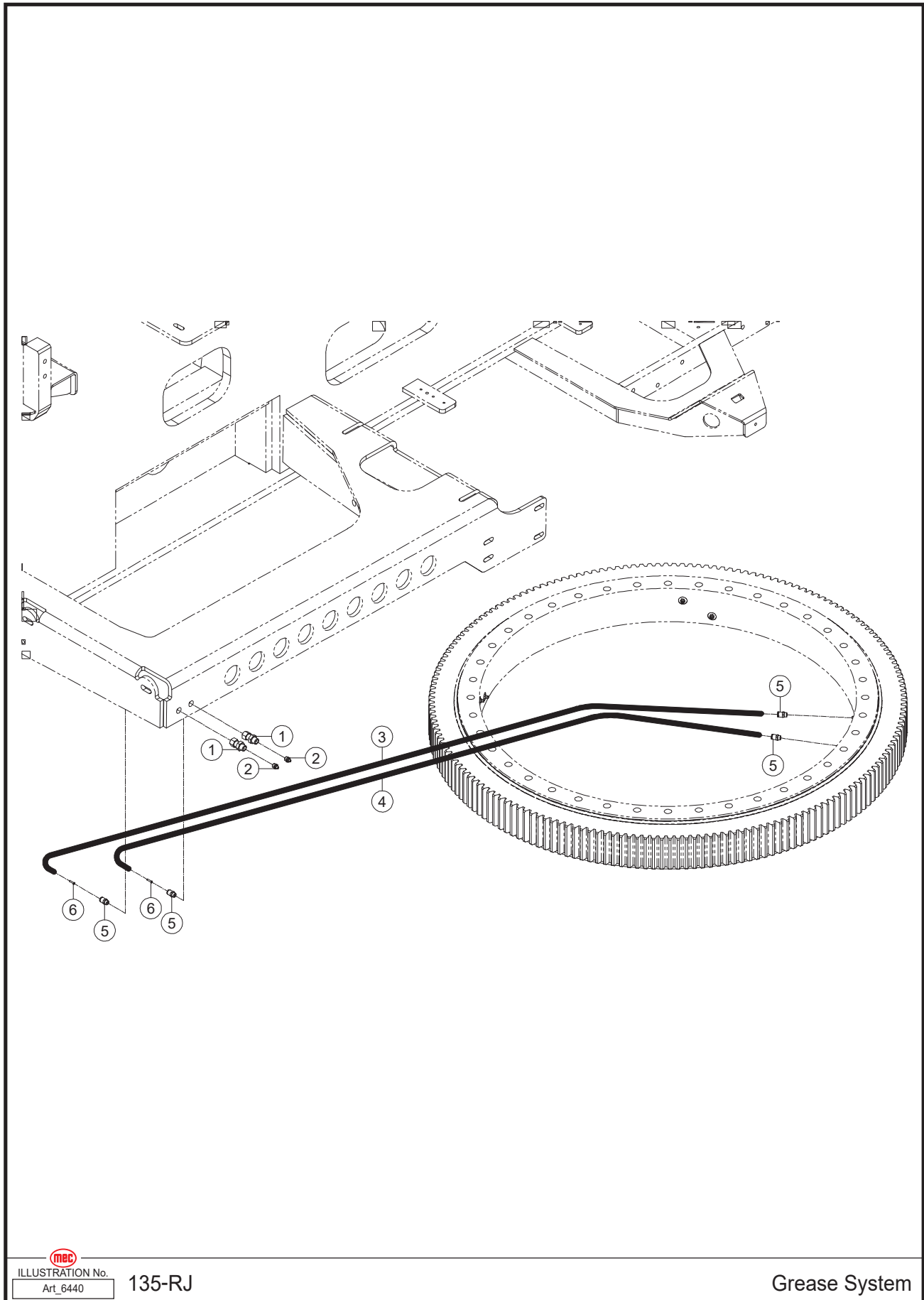



 ILLUSTRATION No. 135-RJ
Art_6439

Housing Covers

Item	Part Number	Description	Qty.
1	47750	Spring Washer	6
2	60043	Screw HHCS M08-1.25 × 25 ZP	6
3	60520	Housing	1
4	60444	Spring Washer	11
5	60019	Screw HHCS M10-1.50 × 20 ZP	7
6	60770	Housing	1
7	60580	Housing	2
8	60017	Nut NNYL M10-1.50 ZP	1
9	50033	Screw HHCS M10-1.50 × 25 ZP	3
10	49264	Support	1

Grease System

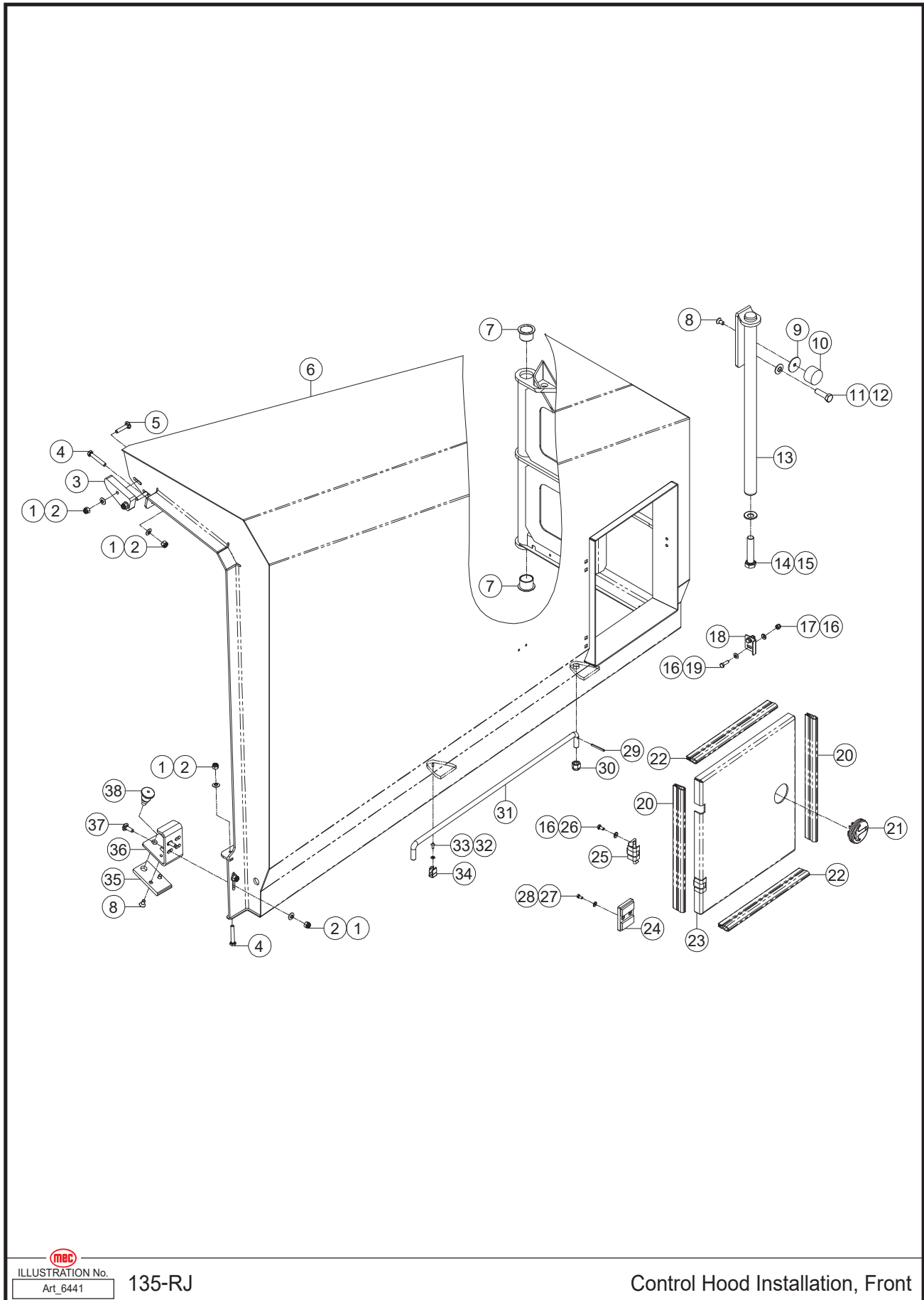



ILLUSTRATION No. 135-RJ
Art_6440

Grease System

Item	Part Number	Description	Qty.
1	48829	Fitting	2
2	48828	Grease Nipple	2
3	60478	Grease Hose	1
4	60738	Grease Hose	1
5	48830	Fitting	4
6	60818	Brass Sleeve	4

Control Hood Installation, Front

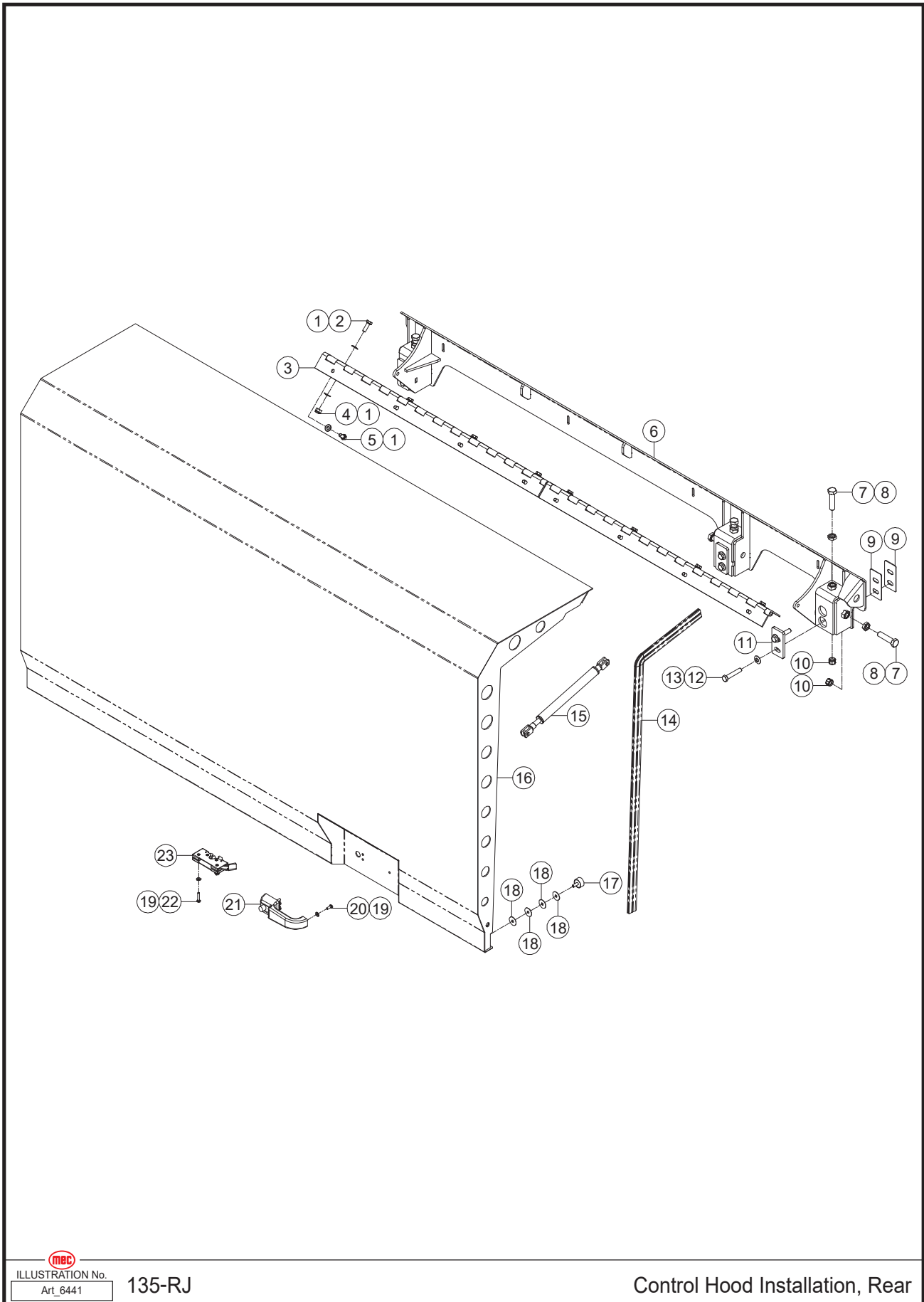



 ILLUSTRATION No. 135-RJ
Art_6441

Control Hood Installation, Front

Item	Part Number	Description	Qty.
1	47750	Spring Washer	6
2	60070	Nut NNYL M08-1.25 ZP	6
3	60803	Space	1
4	60148	Screw HHCS M08-1.25 × 50 ZP	2
5	60213	Square Neck Carriage Bolt M08-1.25 × 40 ZP	2
6	60563	Turntable Hood (Right Front)	1
7	48667	Sleeve Bearing	2
8	53434	Screw CSCS M08-1.25 × 16 ZP	3
9	48189	Shim	1
10	47614	Rubber Mounting	1
11	60060	Screw HHCS M12-1.75 × 40 ZP	2
12	60445	Spring Washer	2
13	60603	Pin	1
14	60199	Screw HHCS M16-2.00 × 75 ZP	1
15	60840	Spring Washer	1
16	48186	Spring Washer	8
17	50028	Screw HHCS M06-1.00 × 20 ZP	2
18	60813	Support	1
19	60048	Nut NNYL M06-1.00 ZP	2
20	60610	Seal	2
21	60810	Lock	1
22	60609	Seal	2
23	60806	Housing	1
24	60812	Magnet	1
25	60811	Hinge	2
26	60026	Screw HHCS M06-1.00 × 12 ZP	4
27	53420	Screw HHCS M05-0.80 × 10 ZP	2
28	60443	Spring Washer	2
29	48764	Pin	1
30	60074	Nut NNYL M12-1.75 ZP	1
31	49265	Stay Bar	1
32	60006	WSHR M05 Standard Flat Washer ZP	1
33	53175	Screw BHCS M05-0.80 × 10 ZP	1
34	48763	Clamp	1
35	60802	Space	1
36	60601	Bracket	1
37	60212	Square Neck Carriage Bolt M08-1.25 × 25 ZP	2
38	60804	Plunger Pin	1

Control Hood Installation, Rear

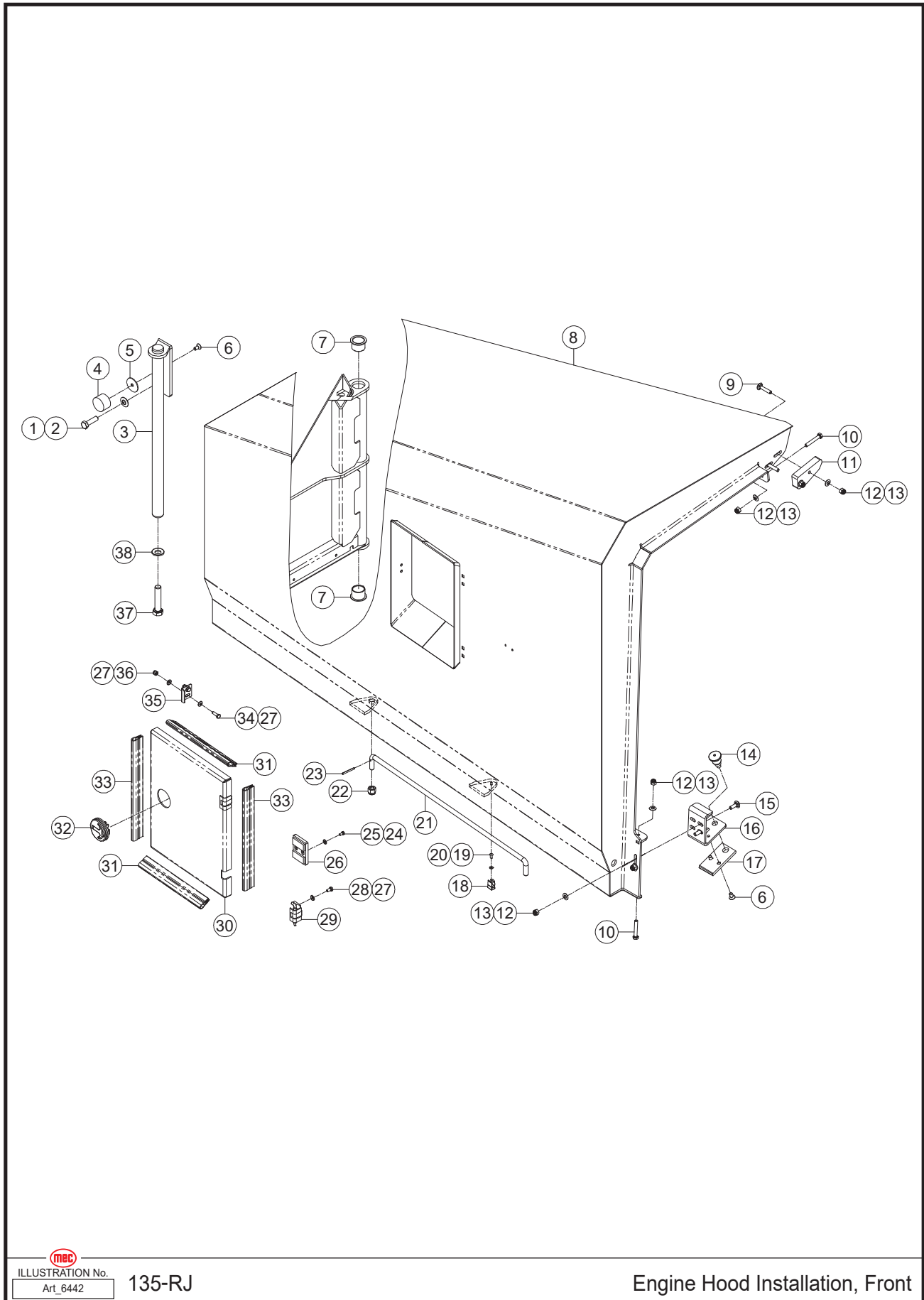



ILLUSTRATION No. 135-RJ
Art_6441

Control Hood Installation, Rear

Item	Part Number	Description	Qty.
1	60444	Spring Washer	24
2	60021	Screw HHCS M10-1.50 × 30 ZP	8
3	60773	Hinge	2
4	60017	Nut NNYL M10-1.50 ZP	8
5	60019	Screw HHCS M10-1.50 × 20 ZP	8
6	60582	Bracket	1
7	60121	Screw HHCS M16-2.00 × 65 ZP	5
8	60135	Nut NHEX M16-2.00, Thin Nut Chamfered ZP	5
9	60519	Shim	6
10	60774	Screw Cap	5
11	60776	Shim	3
12	60125	Screw HHCS M12-1.75 × 65 ZP	6
13	60445	Spring Washer	6
14	60604	Seal	1
15	60585	Spring, Gas	2
16	60564	Turntable Hood (Right Rear)	1
17	49021	Rubber Mounting	1
18	60480	Shim	4
19	48186	Spring Washer	7
20	50445	Screw HHCS M06-1.00 × 16 ZP	3
21	42353	Doorknob	1
22	60028	Screw HHCS M06-1.00 × 30 ZP	4
23	42896	Lock	1

Engine Hood Installation, Front

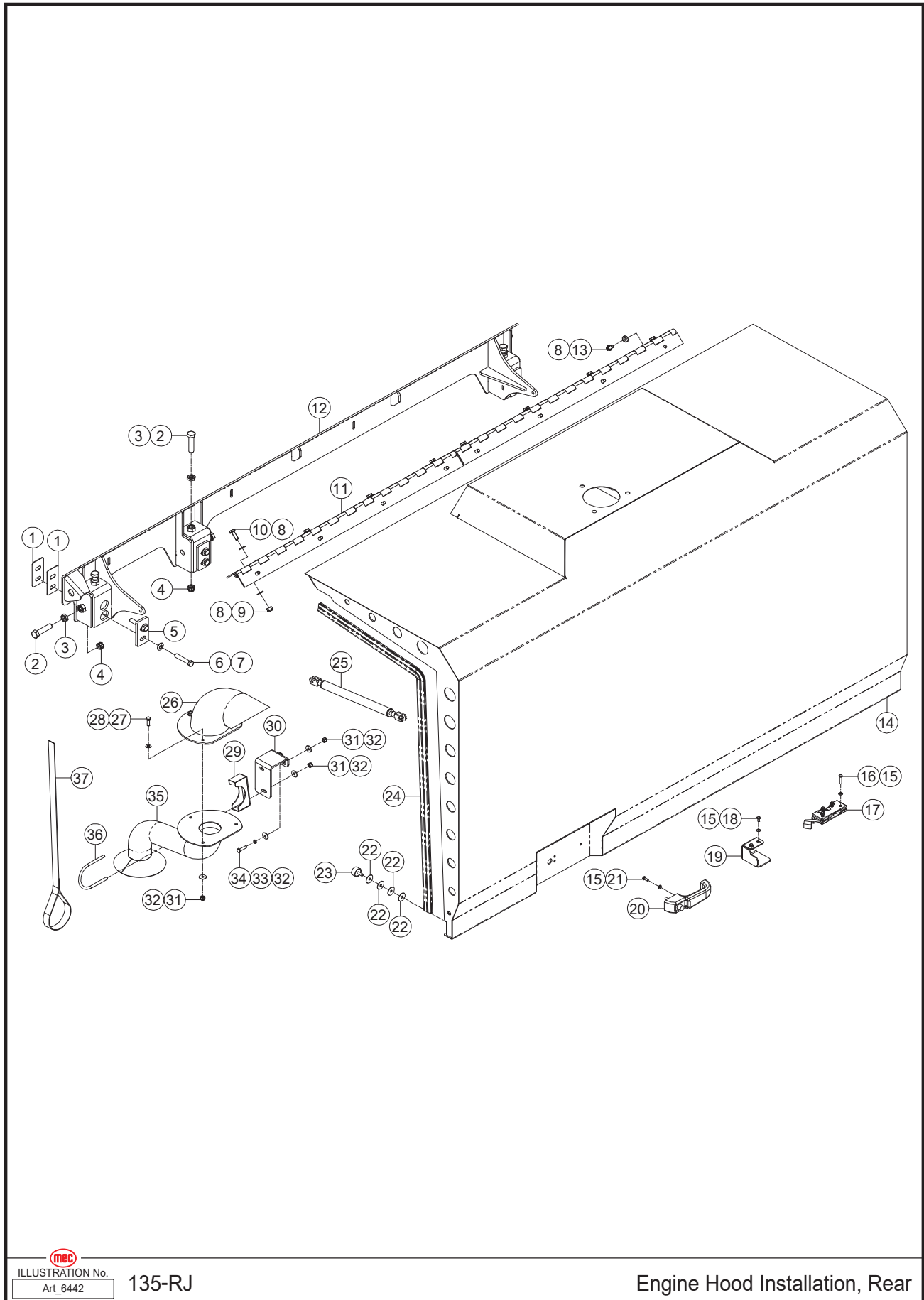



 ILLUSTRATION No. 135-RJ
Art_6442

Engine Hood Installation, Front

Item	Part Number	Description	Qty.
1	60445	Spring Washer	2
2	60060	Screw HHCS M12-1.75 × 40 ZP	2
3	60602	Pin	1
4	47614	Rubber Mounting	1
5	48189	Shim	1
6	53434	Screw CSCS M08-1.25 × 16 ZP	3
7	48667	Sleeve Bearing	2
8	60561	Turntable Hood (Left Front)	1
9	60213	Square Neck Carriage Bolt M08-1.25 × 40 ZP	2
10	60148	Screw HHCS M08-1.25 × 50 ZP	2
11	60803	Space	1
12	60070	Nut NNYL M08-1.25 ZP	6
13	47750	Spring Washer	6
14	60804	Plunger Pin	1
15	60212	Square Neck Carriage Bolt M08-1.25 × 25 ZP	2
16	60601	Bracket	1
17	60802	Space	1
18	48763	Clamp	1
19	53175	Screw BHCS M05-0.80 × 10 ZP	1
20	60006	WSHR M05 Standard Flat Washer ZP	1
21	49265	Brace Rod	1
22	60074	Nut NNYL M12-1.75 ZP	1
23	48764	Pin	1
24	60443	Spring Washer	2
25	53420	Screw HHCS M05-0.80 × 10 ZP	2
26	60812	Magnet	1
27	48186	Spring Washer	8
28	60026	Screw HHCS M06-1.00 × 12 ZP	4
29	60811	Hinge	2
30	60807	Housing	1
31	60608	Seal	2
32	60810	Lock	1
33	60607	Seal	2
34	50028	Screw HHCS M06-1.00 × 20 ZP	2
35	60813	Support	1
36	60048	Nut NNYL M06-1.00 ZP	2
37	60199	Screw HHCS M16-2.00 × 75 ZP	1
38	60840	Spring Washer	1

Engine Hood Installation, Rear

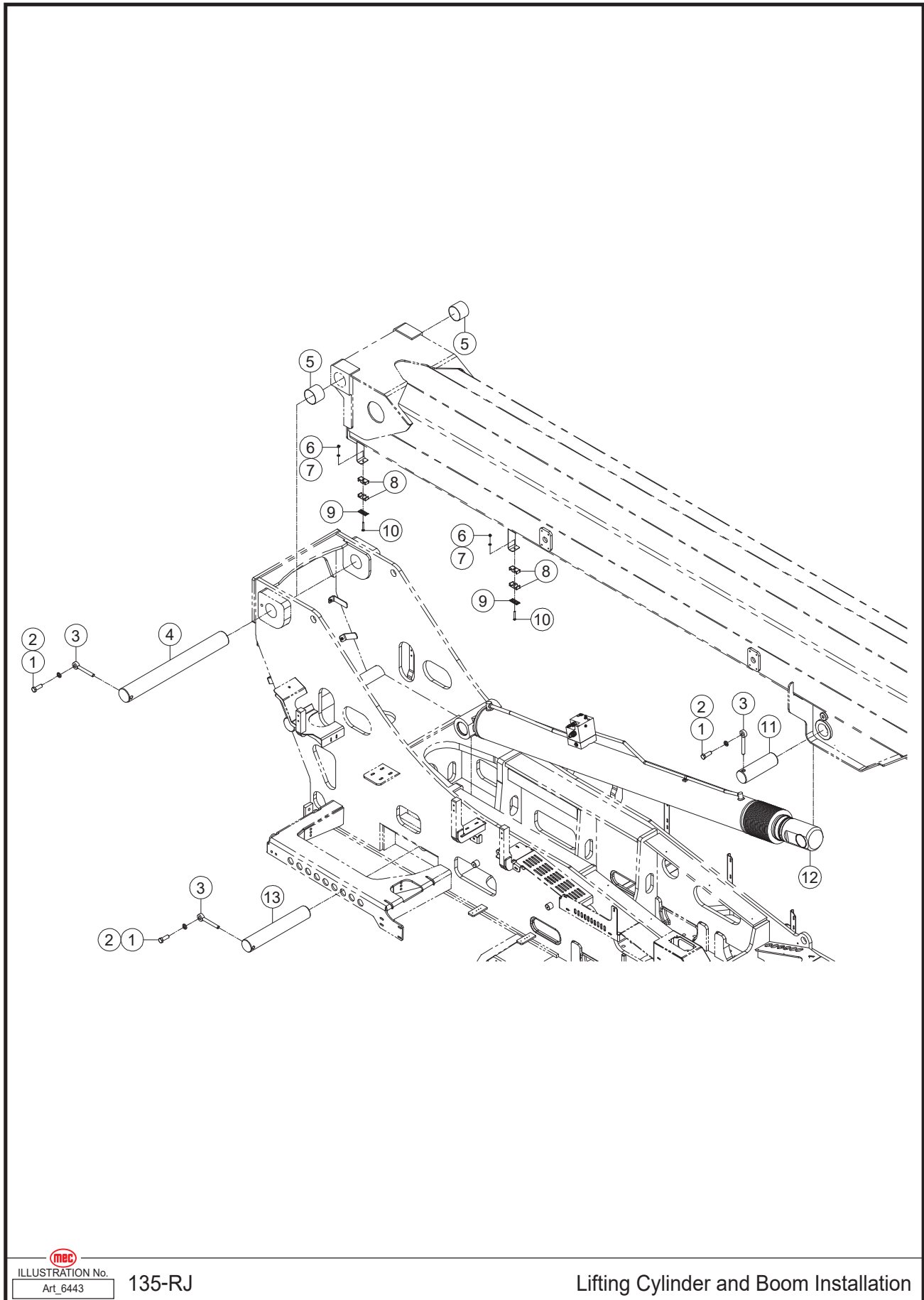



 ILLUSTRATION No. 135-RJ
Art_6442

Engine Hood Installation, Rear

Item	Part Number	Description	Qty.
1	60519	Shim	6
2	60121	Screw HHCS M16-2.00 × 65 ZP	5
3	60135	Nut NHEX M16-2.00, Thin Nut Chamfered ZP	5
4	60774	Screw Cap	5
5	60776	Shim	3
6	60125	Screw HHCS M12-1.75 × 65 ZP	6
7	60445	Spring Washer	6
8	60444	Spring Washer	24
9	60017	Nut NNYL M10-1.50 ZP	8
10	60021	Screw HHCS M10-1.50 × 30 ZP	8
11	60773	Hinge	2
12	60581	Bracket	1
13	60019	Screw HHCS M10-1.50 × 20 ZP	8
14	60562	Turntable Hood (Left Rear)	1
15	48186	Spring Washer	9
16	60028	Screw HHCS M06-1.00 × 30 ZP	4
17	42896	Lock	1
18	60026	Screw HHCS M06-1.00 × 12 ZP	2
19	47904	Housing	1
20	42353	Doorknob	1
21	50445	Screw HHCS M06-1.00 × 16 ZP	3
22	60480	Shim	4
23	49021	Rubber Mounting	1
24	60605	Seal	1
25	60775	Spring, Gas	2
26	47895	Exhaust Tube	1
27	60043	Screw HHCS M08-1.25 × 25 ZP	3
28	47750	Spring Washer	3
29	60514	Bracket	1
30	49266	Bracket	1
31	60070	Nut NNYL M08-1.25 ZP	7
32	60090	WSHR M08 Flat Fender Washer ZP	9
33	60009	WSHR M08 Spring Washer ZP	2
34	60044	Screw HHCS M08-1.25 × 30 ZP	2
35	49267	Connecting Pipe	1
36	60513	Clamp	1
37	60544	Tie	1

Lifting Cylinder and Boom Installation



 ILLUSTRATION No. 135-RJ
Art_6443

Lifting Cylinder and Boom Installation

Item	Part Number	Description	Qty.
1	60176	Screw HHCS M20-2.50 × 60 ZP	3
2	47601	Flat Washer	3
3	60004	Pin, Lock	3
4	60779	Pin, Pivot	1
5	60627	Sleeve Bearing	2
6	60070	Nut NNYL M08-1.25 ZP	1
7	47750	Spring Washer	1
8	60410	Clamp	2
9	60411	Spacer	1
10	60088	Screw HHCS M08-1.25 × 60 ZP	1
11	60781	Pin, Pivot	1
12	REF	Lifting Cylinder Assembly (Refer to page 202)	1
13	49268	Pin, Pivot	1

REF – Reference

Telescopic Boom

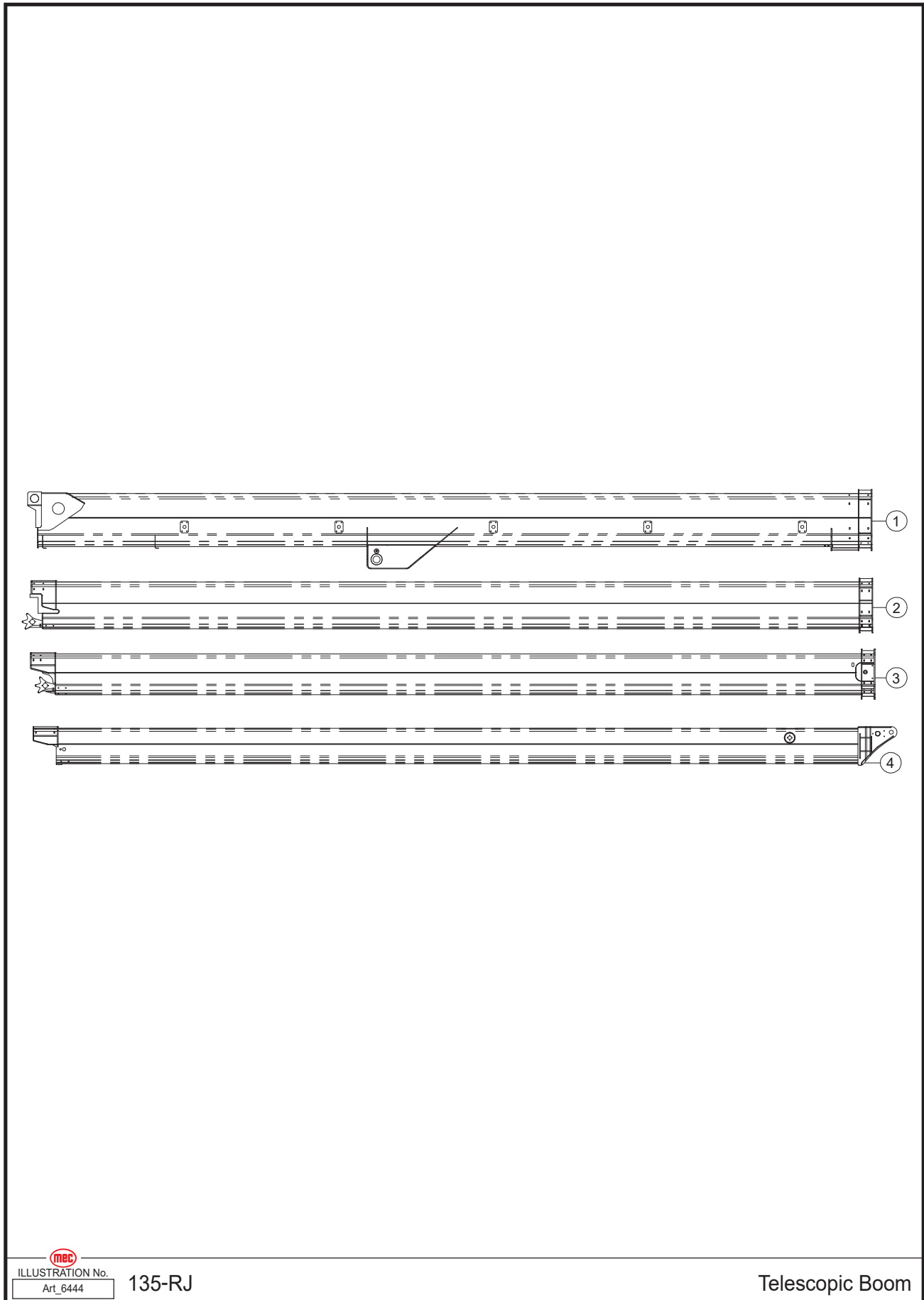
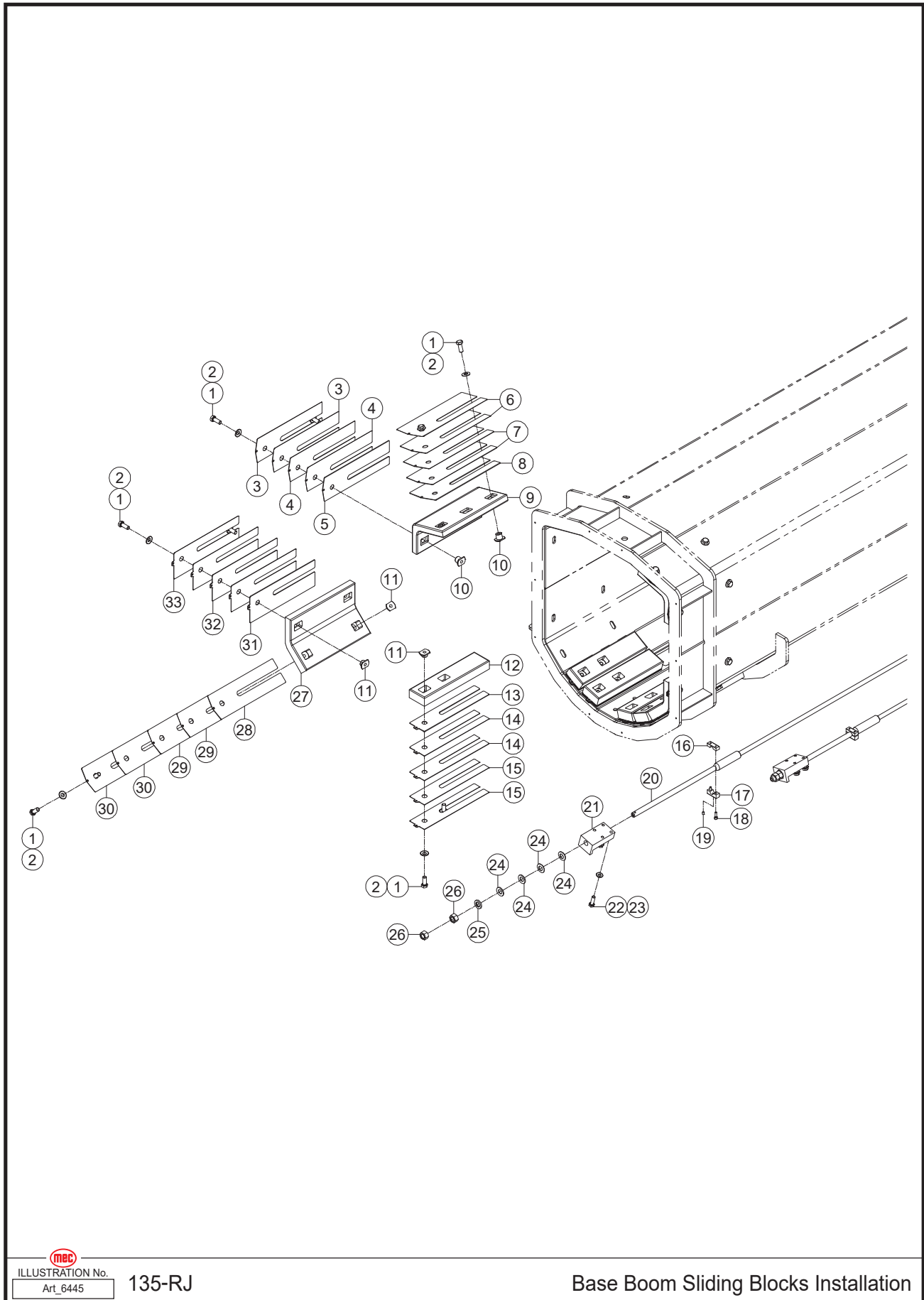



 ILLUSTRATION No. 135-RJ
Art_6444

Telescopic Boom

Item	Part Number	Description	Qty.
1	60551	Base Boom	1
2	60550	Second Boom	1
3	60549	Third Boom	1
4	49269	Fourth Boom	1

Base Boom Sliding Blocks Installation

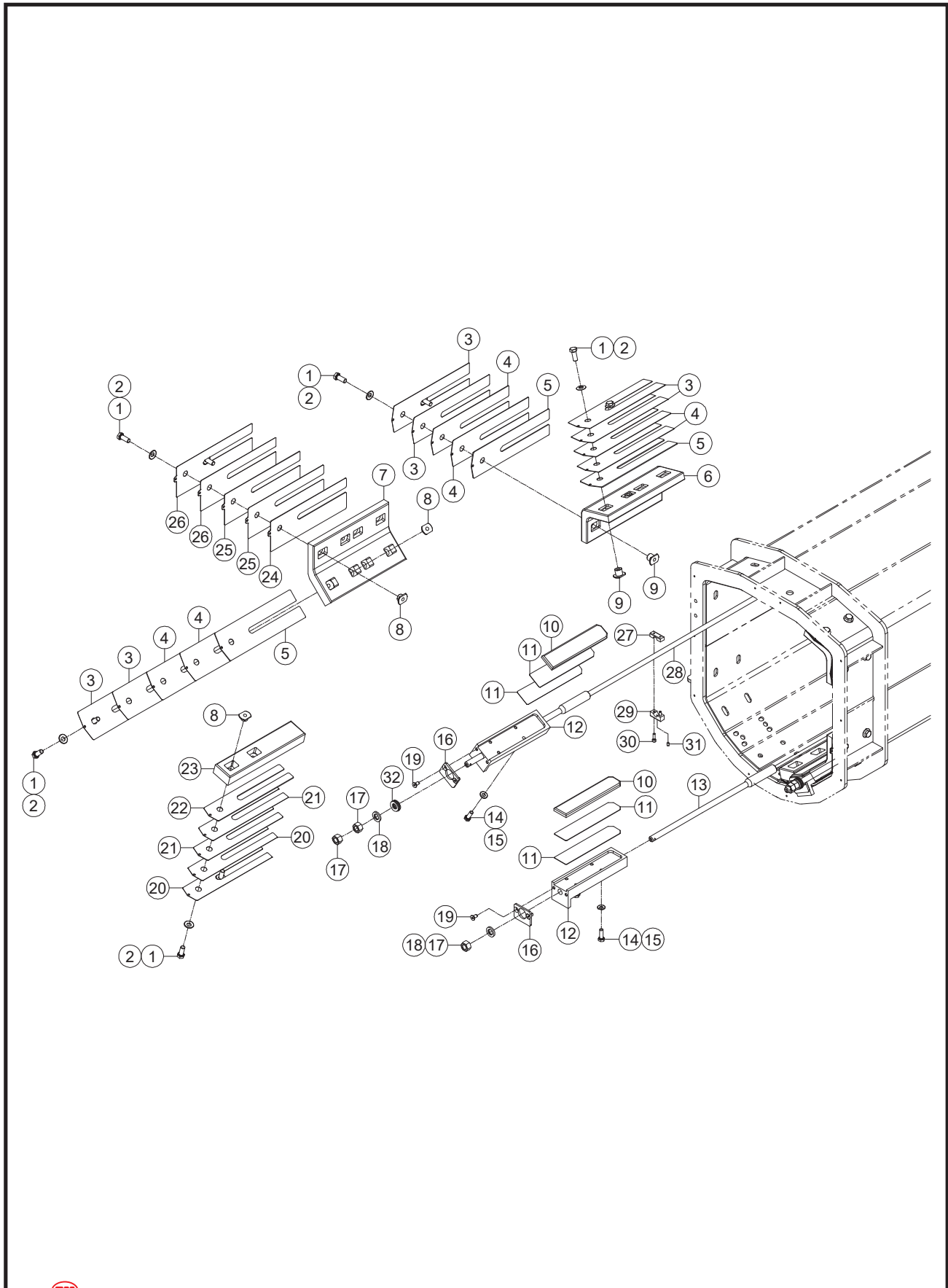



ILLUSTRATION No. 135-RJ
Art_6445

Base Boom Sliding Blocks Installation

Item	Part Number	Description	Qty.
1	60096	Screw HHCS M12-1.75 × 30 ZP	26
2	60445	Spring Washer	26
3	60663	Shim	4
4	60664	Shim	4
5	60665	Shim	2
6	60701	Shim	4
7	60702	Shim	4
8	60703	Shim	2
9	60636	Sliding Block	2
10	60789	Insert	8
11	60654	Insert	18
12	60635	Sliding Block	5
13	60686	Shim	5
14	60685	Shim	10
15	60684	Shim	10
16	60730	Plate	2
17	60731	Plate	2
18	60027	Screw SHCS M06-1.00 × 20 ZP	4
19	60217	Set Screw M06-1.00 × 10 Cone Point ZP	2
20	60651	Cable	2
21	60656	Plate	2
22	60022	Screw HHCS M10-1.50 × 35 ZP	8
23	60444	Spring Washer	8
24	60838	Washer	8
25	60064	Flat Washer	2
26	60225	Nut NHEX M16-1.50 ZP	4
27	60637	Sliding Block	2
28	60689	Shim	2
29	60688	Shim	4
30	60687	Shim	4
31	60692	Shim	2
32	60691	Shim	4
33	60690	Shim	4

Second Boom Sliding Blocks Installation Part 1



 ILLUSTRATION No. 135-RJ
Art_6446

Second Boom Sliding Blocks Installation

Item	Part Number	Description	Qty.
1	60096	Screw HHCS M12-1.75 × 30 ZP	20
2	60445	Spring Washer	20
3	60687	Shim	12
4	60688	Shim	12
5	60689	Shim	6
6	60633	Sliding Block	2
7	60634	Sliding Block	2
8	60654	Insert	12
9	60789	Insert	8
10	60639	Sliding Block	3
11	60631	Shim	6
12	60638	Bracket	3
13	60763	Cable	1
14	60021	Screw HHCS M10-1.50 × 30 ZP	12
15	60444	Spring Washer	12
16	60640	Plate	3
17	60225	Nut NHEX M16-1.50 ZP	5
18	60064	Flat Washer	3
19	53434	Screw CSCS M08-1.25 × 16 ZP	6
20	60693	Shim	4
21	60694	Shim	4
22	60695	Shim	2
23	60632	Sliding Block	2
24	60692	Shim	2
25	60691	Shim	4
26	60690	Shim	4
27	60730	Bracket	2
28	60652	Cable	2
29	60731	Bracket	2
30	60027	Screw SHCS M06-1.00 × 20 ZP	4
31	60217	Set Screw M06-1.00 × 10 Cone Point ZP	2
32	60496	Disc Spring	2

Second Boom Sliding Blocks Installation Part 2

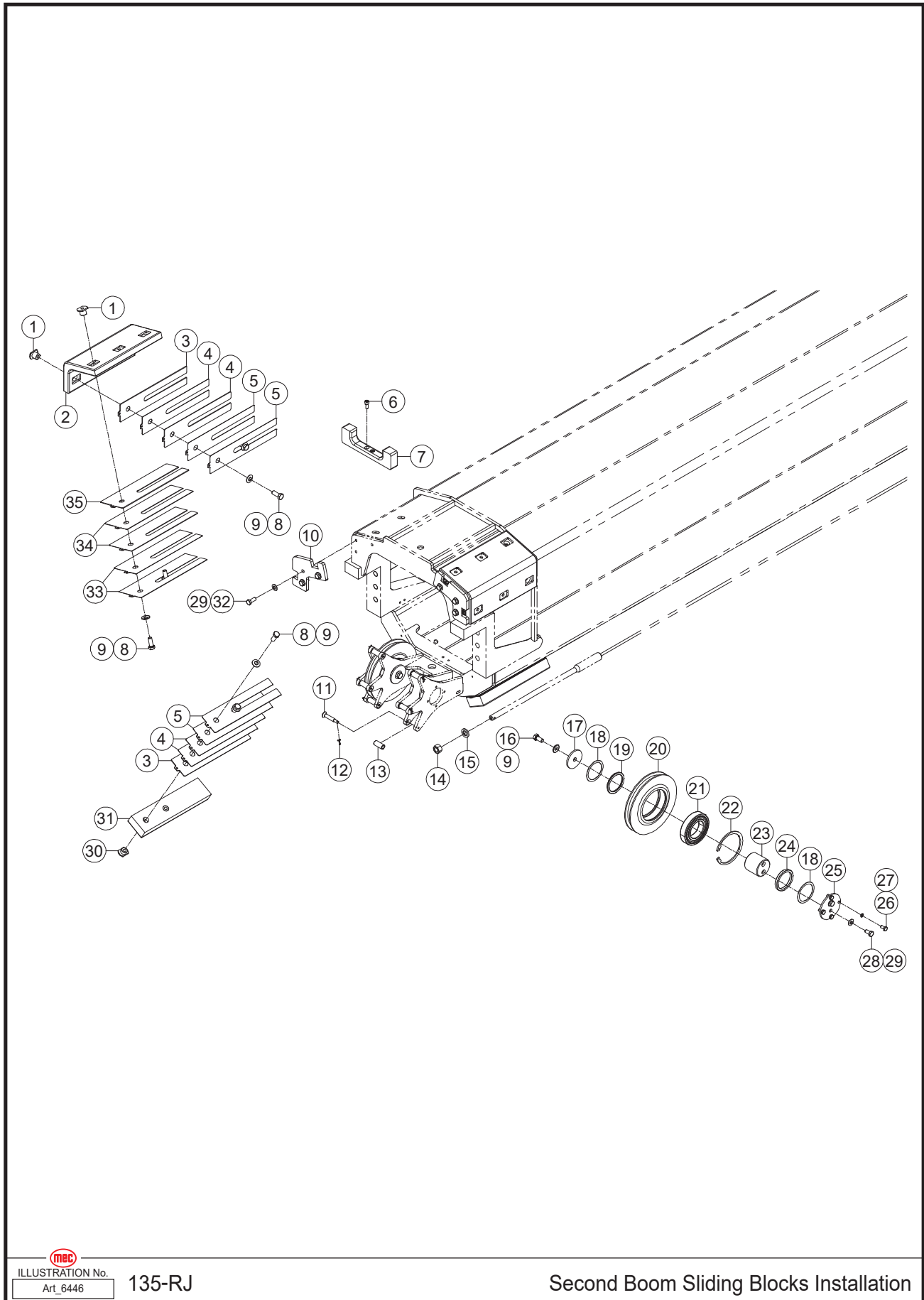

 ILLUSTRATION No. 135-RJ
Art_6446

Second Boom Sliding Blocks Installation

Item	Part Number	Description	Qty.
1	60789	Insert	8
2	60636	Sliding Block	2
3	60686	Shim	4
4	60685	Shim	8
5	60684	Shim	8
6	60062	Screw SHCS M08-1.25 × 20 ZP	2
7	60749	Guide Plate	1
8	60096	Screw HHCS M12-1.75 × 30 ZP	12
9	60445	Spring Washer	14
10	60712	Plate	2
11	60483	Pin, Pivot	6
12	60158	Cotter Pin	6
13	60482	Roller	6
14	60225	Nut NHEX M16-1.50 ZP	1
15	60064	Flat Washer	1
16	60032	Screw HHCS M12-1.75 × 25 ZP	2
17	60795	Cover	2
18	60501	Shim	4
19	60500	Spacer	2
20	60643	Sheave	2
21	60642	Bearing	2
22	60655	Lock Ring	2
23	60791	Pin, Pivot	2
24	60499	Spacer	2
25	60481	Cover	2
26	60063	Screw HHCS M08-1.25 × 16 ZP	8
27	60841	Spring Washer	8
28	60019	Screw HHCS M10-1.50 × 20 ZP	4
29	60444	Spring Washer	10
30	60654	Insert	4
31	60635	Sliding Block	2
32	50033	Screw HHCS M10-1.50 × 25 ZP	6
33	60690	Shim	4
34	60691	Shim	4
35	60692	Shim	2

Third Boom Sliding Blocks Installation Part 1

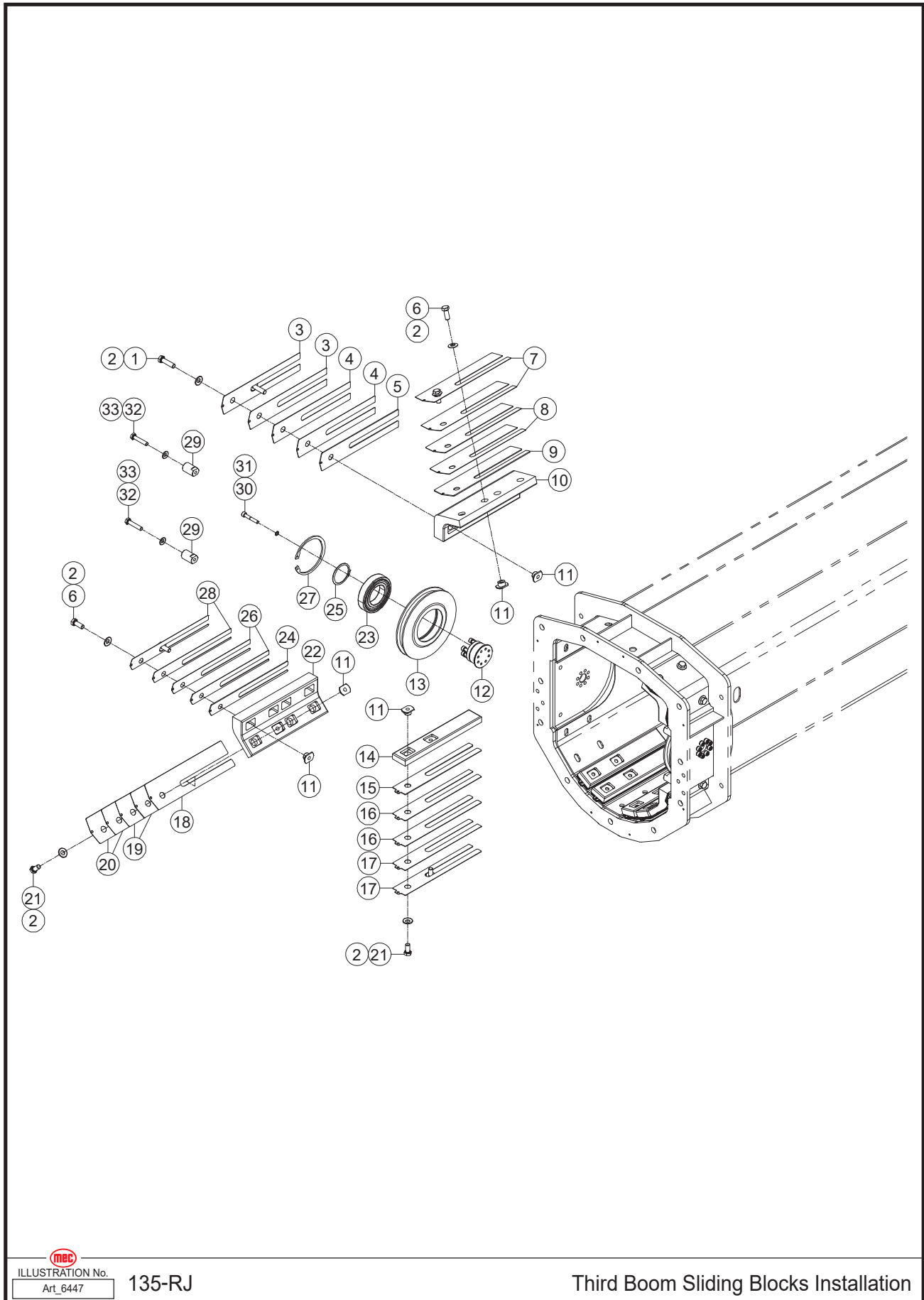



ILLUSTRATION No. 135-RJ
Art_6447

Third Boom Sliding Blocks Installation

Item	Part Number	Description	Qty.
1	60120	Screw HHCS M12-1.75 × 45 ZP	4
2	60445	Spring Washer	26
3	60681	Shim	4
4	60682	Shim	4
5	60683	Shim	2
6	60096	Screw HHCS M12-1.75 × 30 ZP	8
7	60675	Shim	4
8	60676	Shim	4
9	60677	Shim	2
10	60719	Sliding Block	2
11	60654	Insert	26
12	60659	Pin, Pivot	2
13	60643	Sheave	2
14	60626	Sliding Block	5
15	60662	Shim	5
16	60661	Shim	10
17	60660	Shim	10
18	60674	Shim	2
19	60673	Shim	4
20	60672	Shim	4
21	60032	Screw HHCS M12-1.75 × 25 ZP	14
22	60629	Sliding Block	2
23	60642	Bearing	2
24	60680	Shim	2
25	60042	Washer	2
26	60679	Shim	4
27	60655	Lock Ring	2
28	60678	Shim	4
29	60720	Rod	4
30	60129	Screw SHCS M08-1.25 × 50 ZP	16
31	60841	Spring Washer	16
32	60058	Screw HHCS M10-1.50 × 50 ZP	4
33	60444	Spring Washer	4

Third Boom Sliding Blocks Installation Part 2

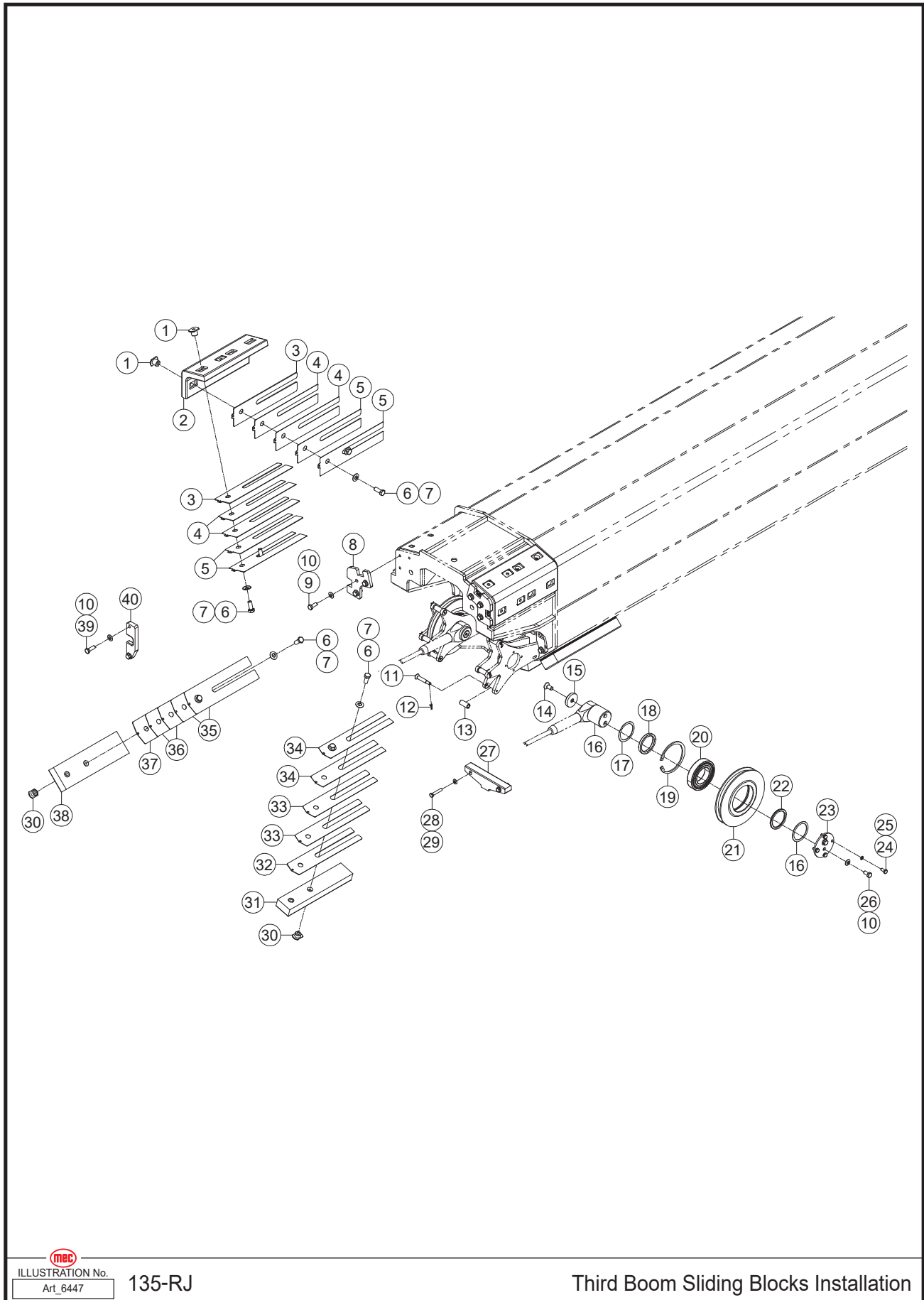

 ILLUSTRATION No. 135-RJ
Art_6447

Third Boom Sliding Blocks Installation

Item	Part Number	Description	Qty.
1	60789	Insert	8
2	60633	Sliding Block	2
3	60698	Shim	4
4	60697	Shim	8
5	60696	Shim	8
6	60096	Screw HHCS M12-1.75 × 30 ZP	16
7	60445	Spring Washer	16
8	60710	Plate	2
9	50033	Screw HHCS M10-1.50 × 25 ZP	6
10	60444	Spring Washer	14
11	60483	Pin, Pivot	6
12	60158	Cotter Pin	6
13	60482	Roller	6
14	60039	Screw CSCS M12-1.75 × 25 ZP	2
15	60747	Cover	2
16	60641	Pin, Pivot	2
17	60501	Shim	4
18	60499	Spacer	2
19	60655	Lock Ring	2
20	60642	Bearing	2
21	60643	Sheave	2
22	60500	Spacer	2
23	60481	Cover	2
24	60063	Screw HHCS M08-1.25 × 16 ZP	8
25	60841	Spring Washer	8
26	60019	Screw HHCS M10-1.50 × 20 ZP	4
27	60707	Guide Plate	1
28	60134	Screw HHCS M08-1.25 × 45 ZP	2
29	47750	Spring Washer	2
30	60654	Insert	8
31	60632	Sliding Block	2
32	60695	Shim	2
33	60694	Shim	4
34	60693	Shim	4
35	60669	Shim	4
36	60670	Shim	4
37	60671	Shim	2
38	60628	Sliding Block	2
39	60021	Screw HHCS M10-1.50 × 30 ZP	4
40	60705	Guide Plate	2

Fourth Boom Sliding Blocks Installation

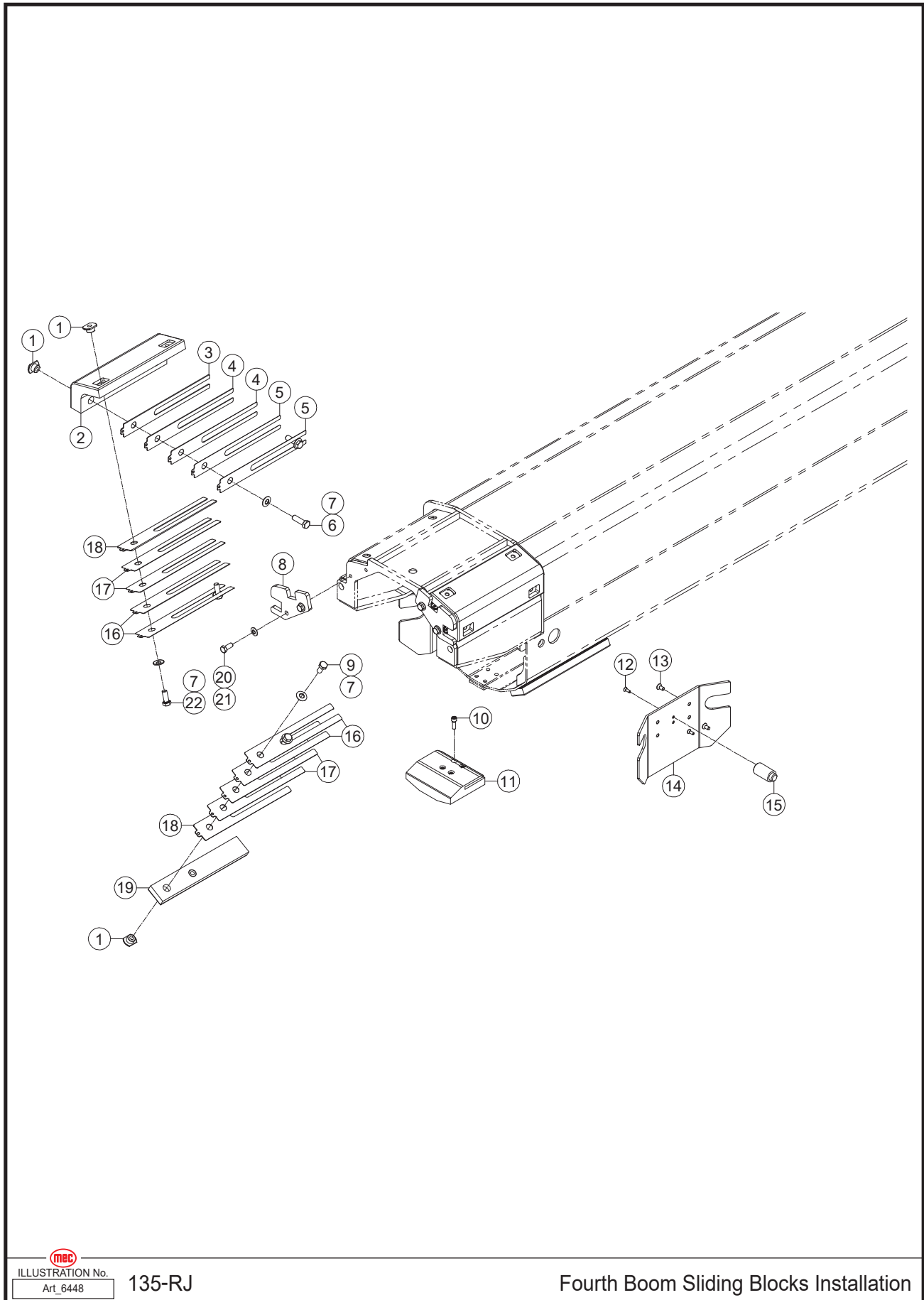
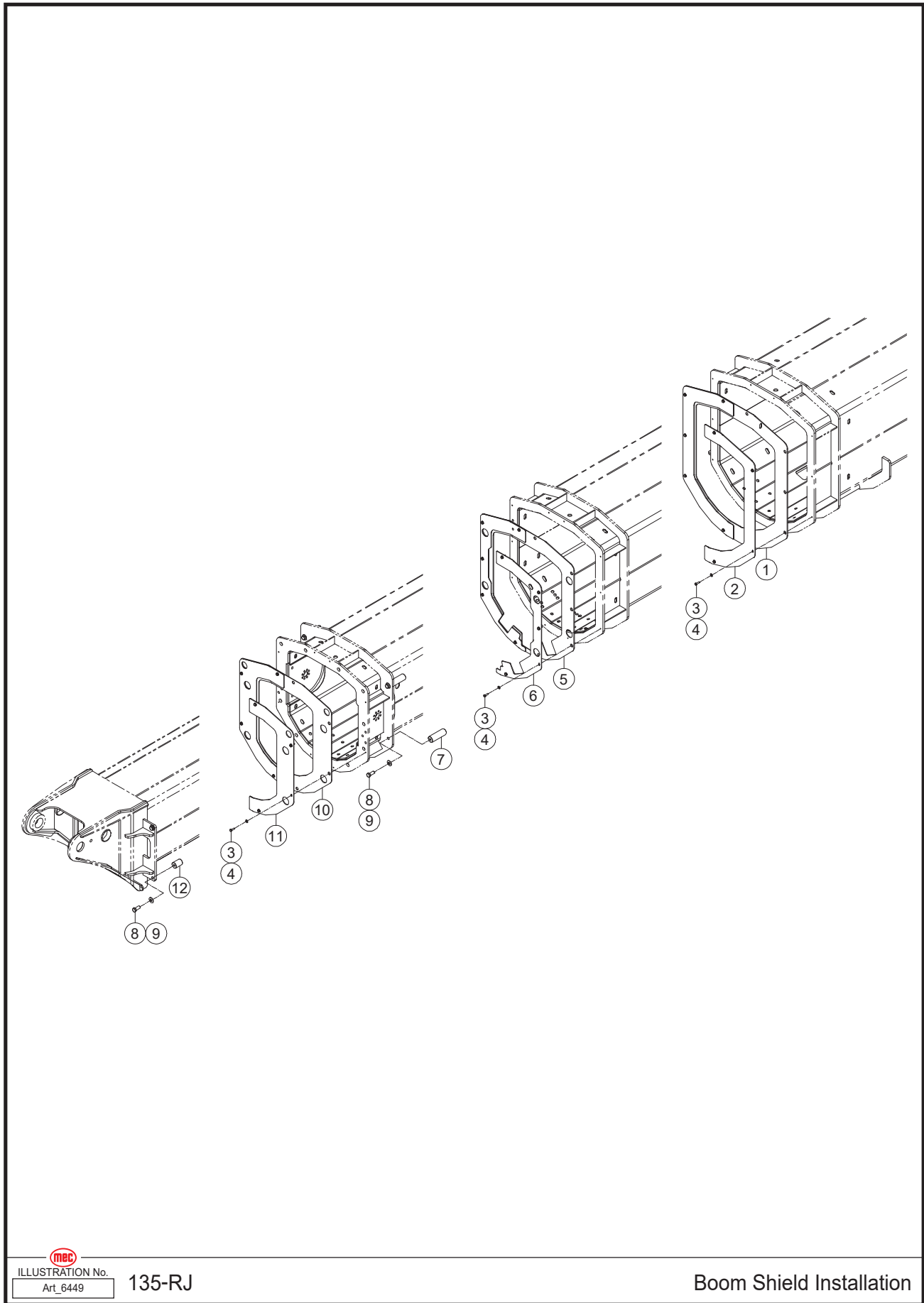



 ILLUSTRATION No. **135-RJ**
Art_6448

Fourth Boom Sliding Blocks Installation

Item	Part Number	Description	Qty.
1	60654	Insert	12
2	60630	Sliding Block	2
3	60668	Shim	2
4	60667	Shim	4
5	60666	Shim	4
6	60060	Screw HHCS M12-1.75 × 40 ZP	4
7	60445	Spring Washer	12
8	60711	Plate	2
9	60032	Screw HHCS M12-1.75 × 25 ZP	4
10	60127	Screw SHCS M08-1.25 × 25 ZP	4
11	60751	Guide Plate	1
12	60035	Screw CSCS M06-1.00 × 16 ZP	4
13	53434	Screw CSCS M08-1.25 × 16 ZP	4
14	60746	Guide Plate	2
15	60745	Pin, Pivot	2
16	60660	Shim	8
17	60661	Shim	8
18	60662	Shim	4
19	60626	Sliding Block	2
20	50033	Screw HHCS M10-1.50 × 25 ZP	4
21	60444	Spring Washer	4
22	60096	Screw HHCS M12-1.75 × 30 ZP	4

Boom Shield Installation

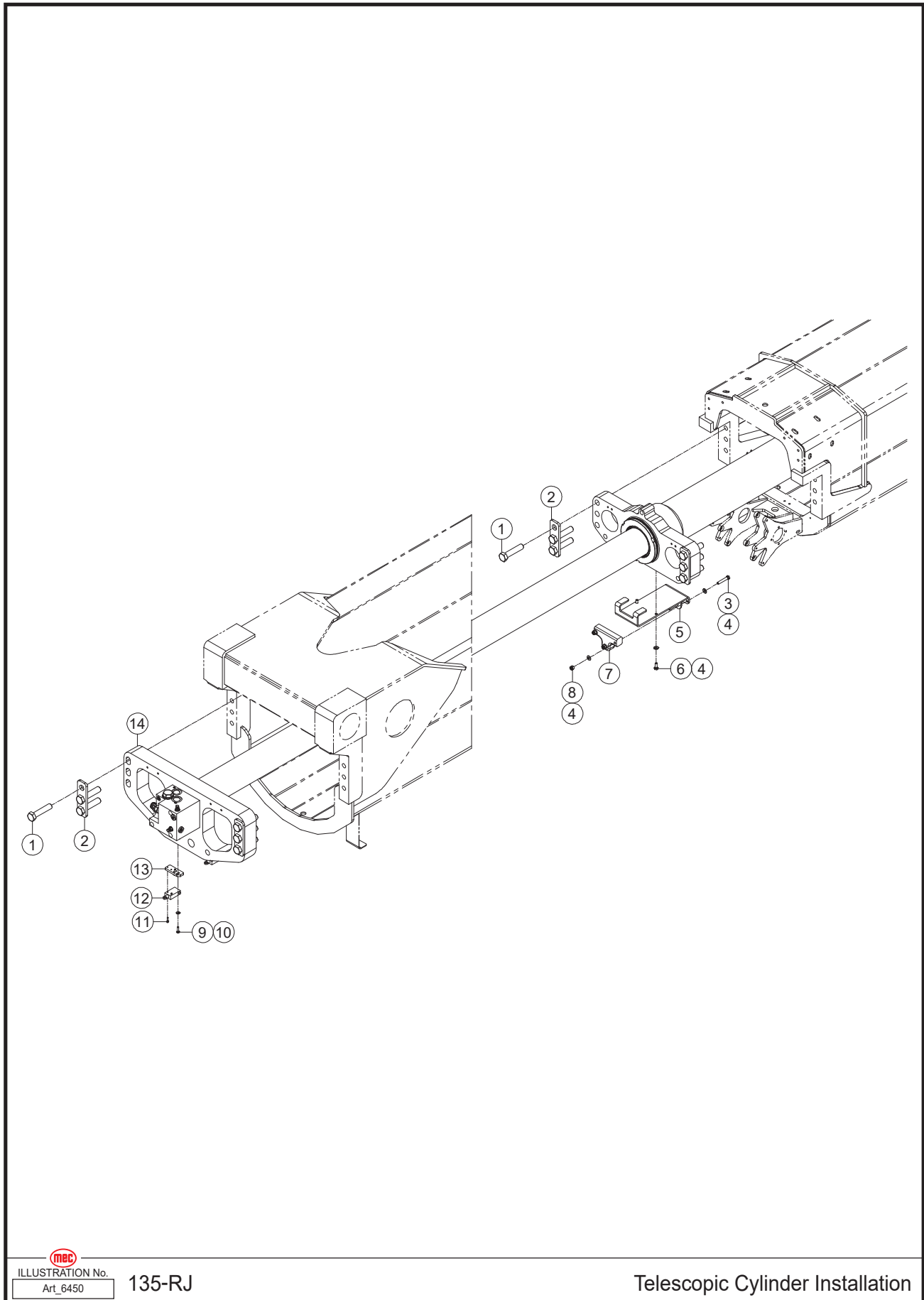



 ILLUSTRATION No. 135-RJ
Art_6449

Boom Shield Installation

Item	Part Number	Description	Qty.
1	60714	Guard (Rubber)	1
2	60713	Plate	2
3	50028	Screw HHCS M06-1.00 × 20 ZP	28
4	48186	Spring Washer	28
5	60716	Guard (Rubber)	1
6	60715	Plate	2
7	60724	Rod	4
8	60096	Screw HHCS M12-1.75 × 30 ZP	8
9	60445	Spring Washer	8
10	60718	Guard (Rubber)	1
11	60717	Plate	2
12	60725	Rod	4

Telescopic Cylinder Installation



 ILLUSTRATION No. 135-RJ
Art_6450

Telescopic Cylinder Installation

Item	Part Number	Description	Qty.
1	60106	Screw HHCS M20-2.50 × 90 ZP	12
2	60788	Plate	4
3	60148	Screw HHCS M08-1.25 × 50 ZP	3
4	47750	Spring Washer	8
5	60708	Guide Plate	1
6	50030	Screw HHCS M08-1.25 × 20 ZP	2
7	60709	Guide Plate	1
8	60070	Nut NNYL M08-1.25 ZP	3
9	50028	Screw HHCS M06-1.00 × 20 ZP	4
10	48186	Spring Washer	4
11	60005	Screw SHCS M04-0.70 × 16 ZP	4
12	44736	Proximity Switch	2
13	60748	Bracket	2
14	REF	Telescopic Cylinder Assembly (Refer to page 204)	1

REF – Reference

Telescopic Cylinder Components Part 1

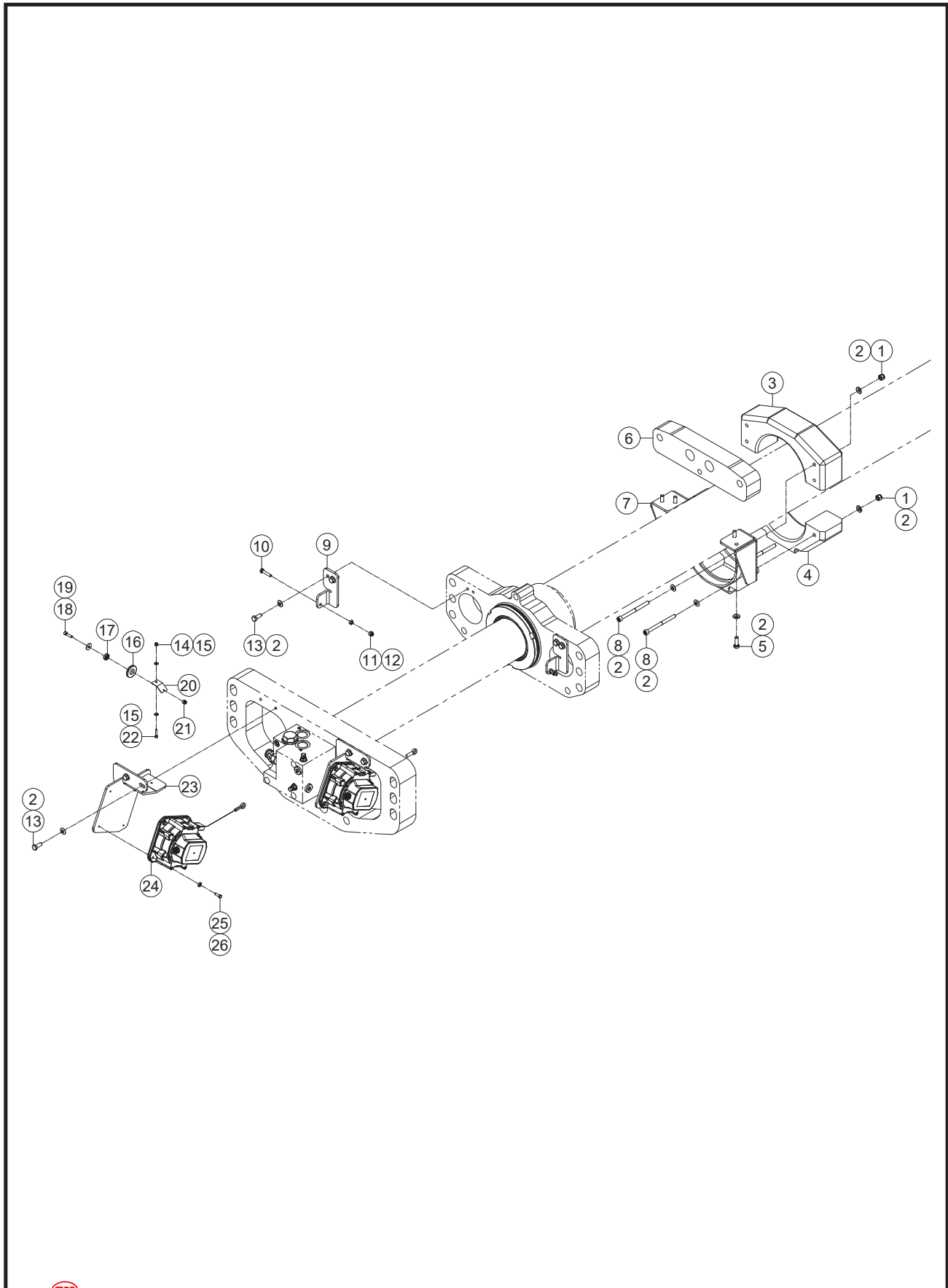

 ILLUSTRATION No. 135-RJ
Art_6451

Telescopic Cylinder Components

Item	Part Number	Description	Qty.
1	60070	Nut NNYL M08-1.25 ZP	6
2	47750	Spring Washer	24
3	60644	Guide Plate	1
4	60646	Guide Plate	1
5	60043	Screw HHCS M08-1.25 × 25 ZP	4
6	60645	Bracket	1
7	60498	Bracket	1
8	60122	Screw SHCS M08-1.25 × 100 ZP	6
9	60765	Bracket	2
10	60028	Screw HHCS M06-1.00 × 30 ZP	2
11	60048	Nut NNYL M06-1.00 ZP	2
12	53361	Nut NHEX M06-1.00 ZP	2
13	50030	Screw HHCS M08-1.25 × 20 ZP	8
14	60072	Nut NNYL M04-0.70 ZP	2
15	60839	Spring Washer	4
16	60816	Pulley	2
17	60817	Bearing	2
18	60033	Screw SHCS M05-0.80 × 20 ZP	2
19	50068	WSHR M06 Flat Fender Washer ZP	2
20	60815	Bracket	2
21	60011	Nut NNYL M05-0.80 ZP	2
22	60098	Screw SHCS M04-0.70 × 20 ZP	2
23	60579	Bracket	2
24	60619	Length Angle Sensor	2
25	53418	Screw HHCS M05-0.80 × 16 ZP	8
26	60443	Spring Washer	8

Telescopic Cylinder Components Part 2

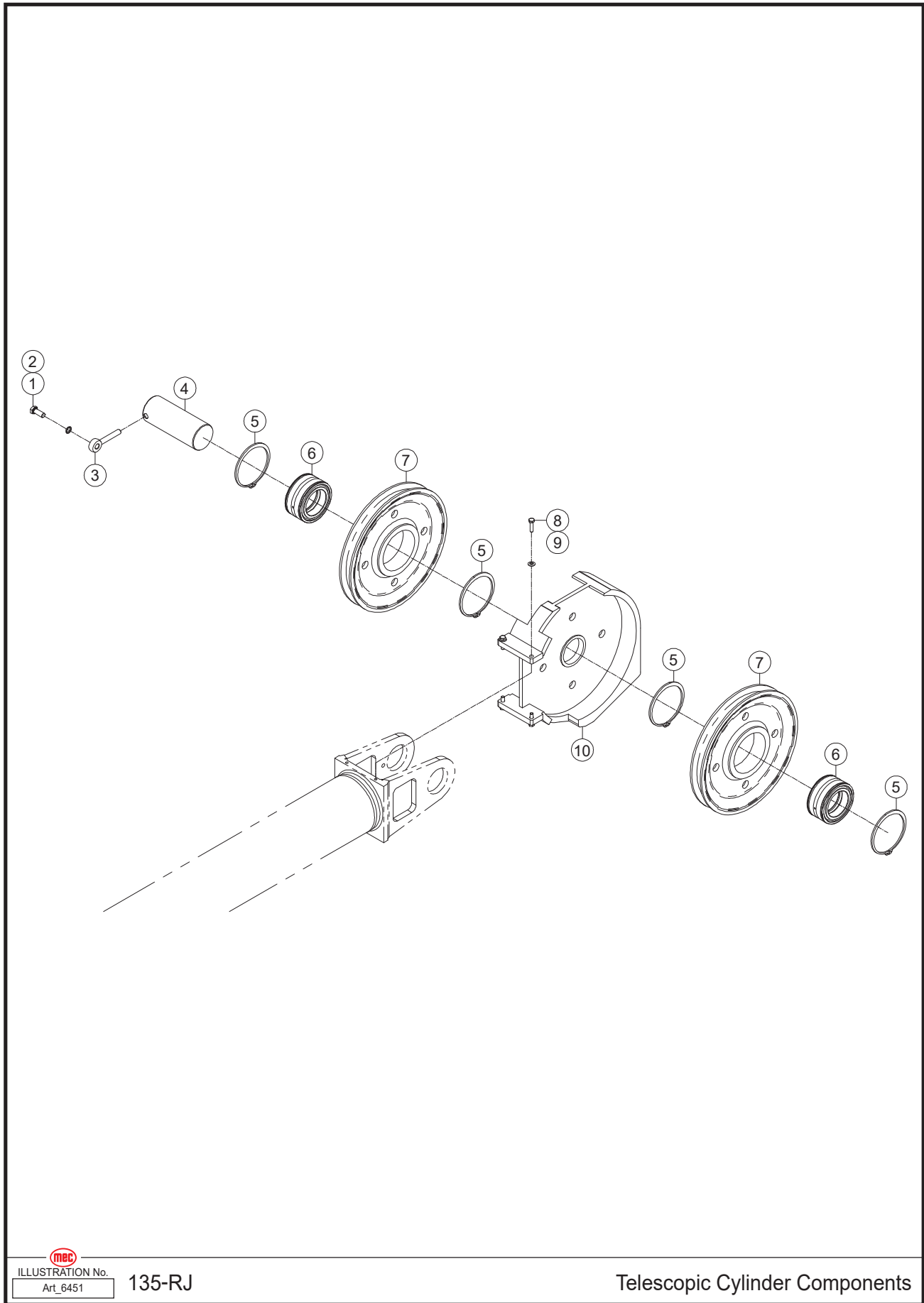
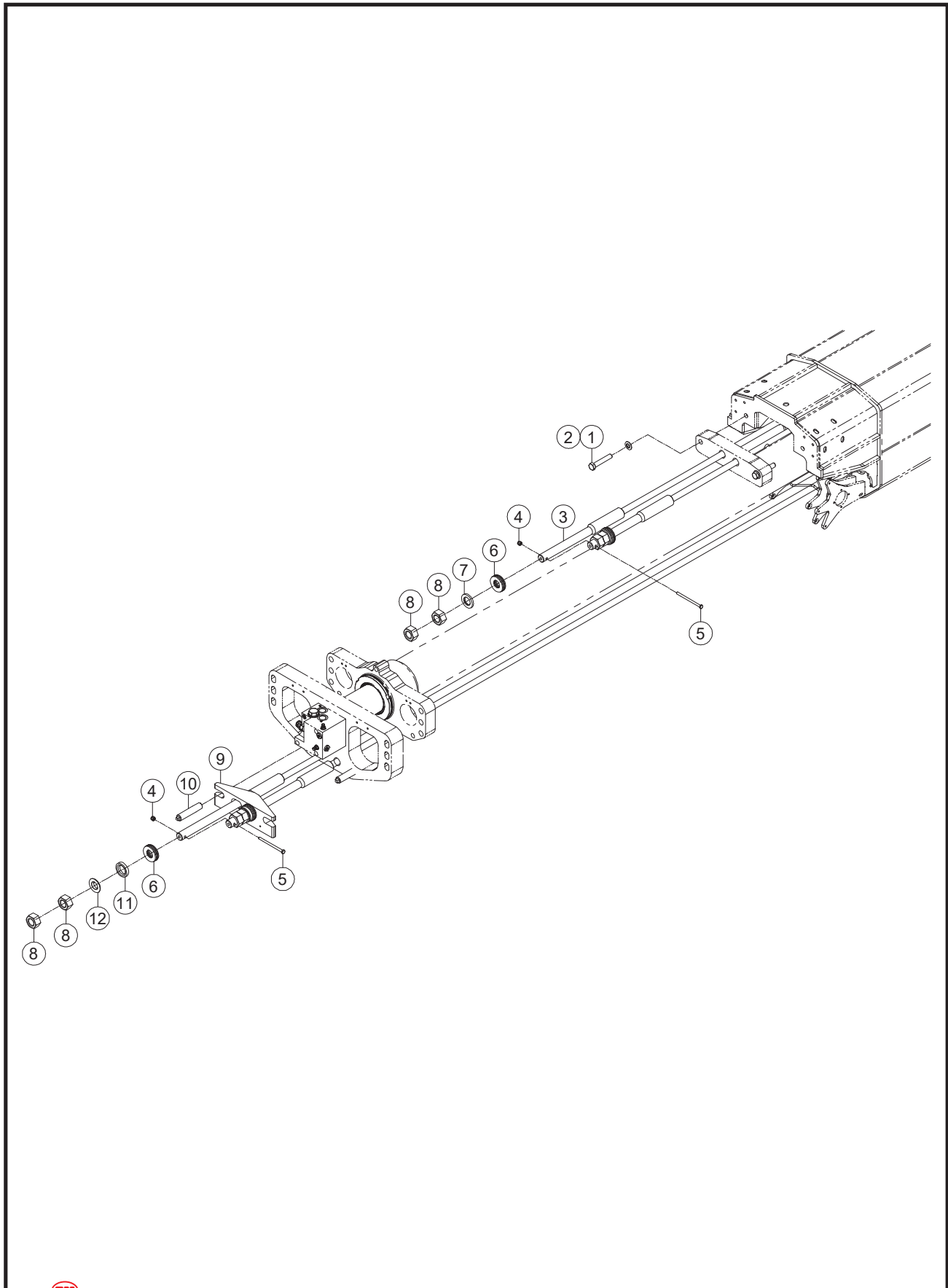



 ILLUSTRATION No. 135-RJ
Art_6451

Telescopic Cylinder Components

Item	Part Number	Description	Qty.
1	60096	Screw HHCS M12-1.75 × 30 ZP	1
2	60843	Spring Washer	1
3	47571	Pin, Lock	1
4	60625	Pin, Pivot	1
5	60722	Lock Ring	4
6	60721	Bearing	2
7	60727	Sheave	2
8	60044	Screw HHCS M08-1.25 × 30 ZP	4
9	47750	Spring Washer	4
10	60706	Guide Plate	1

Third Boom Cable Installation

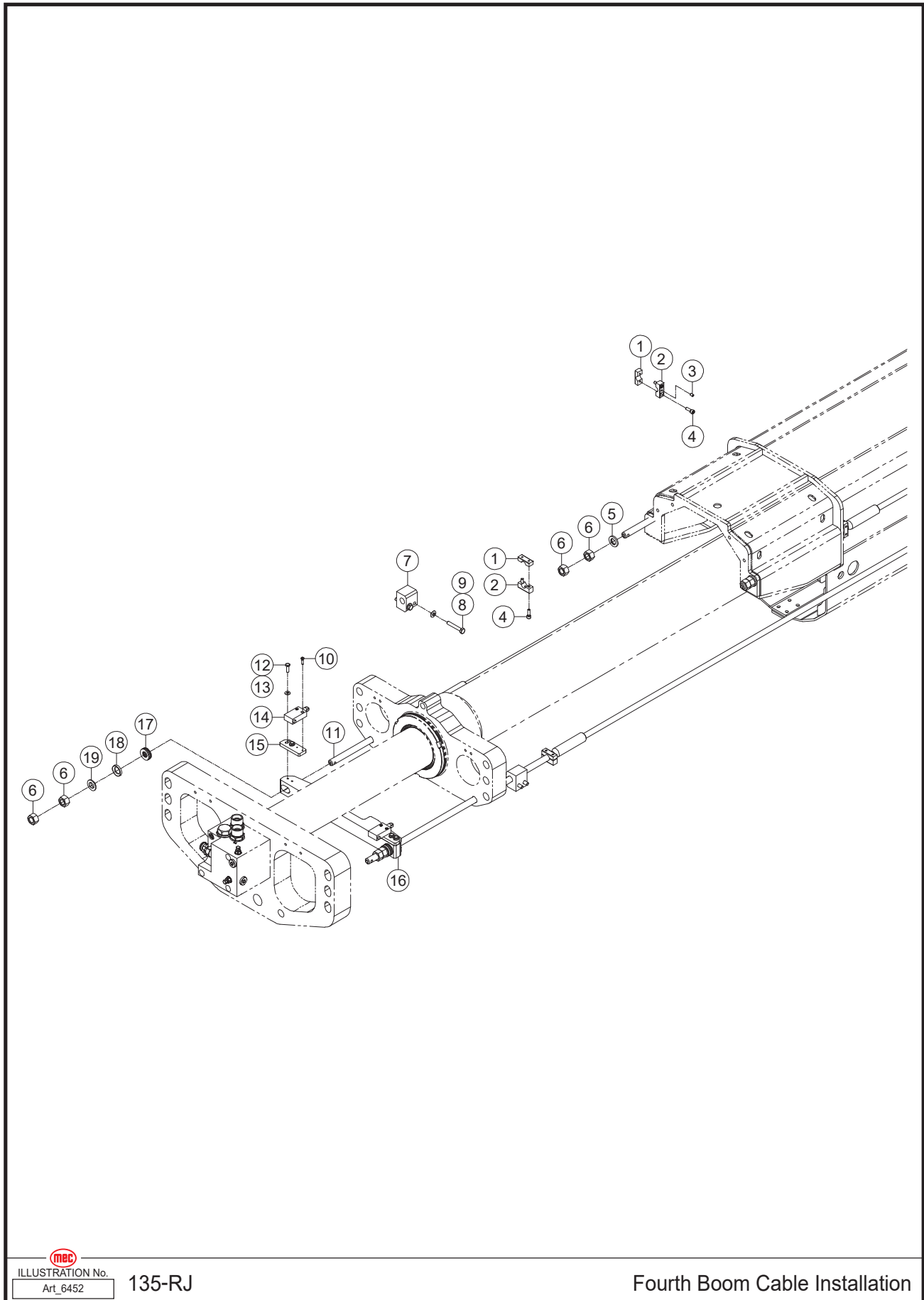



 ILLUSTRATION No. 135-RJ
Art_6451

Third Boom Cable Installation

Item	Part Number	Description	Qty.
1	60107	Screw HHCS M16-2.00 × 90 ZP	2
2	60840	Spring Washer	2
3	49270	Cable	2
4	60070	Nut NNYL M08-1.25 ZP	2
5	60216	Screw HHCS M08-1.25 × 120 ZP	2
6	60490	Disc Spring	4
7	60065	Washer	2
8	60013	Nut NHEX M30-3.50 ZP	8
9	60648	Bracket	1
10	60844	Bolt	2
11	60214	WSHR M30-3.50 Cone Face Washer ZP	2
12	60215	WSHR M30-3.50 Ball Face Washer ZP	2

Fourth Boom Cable Installation

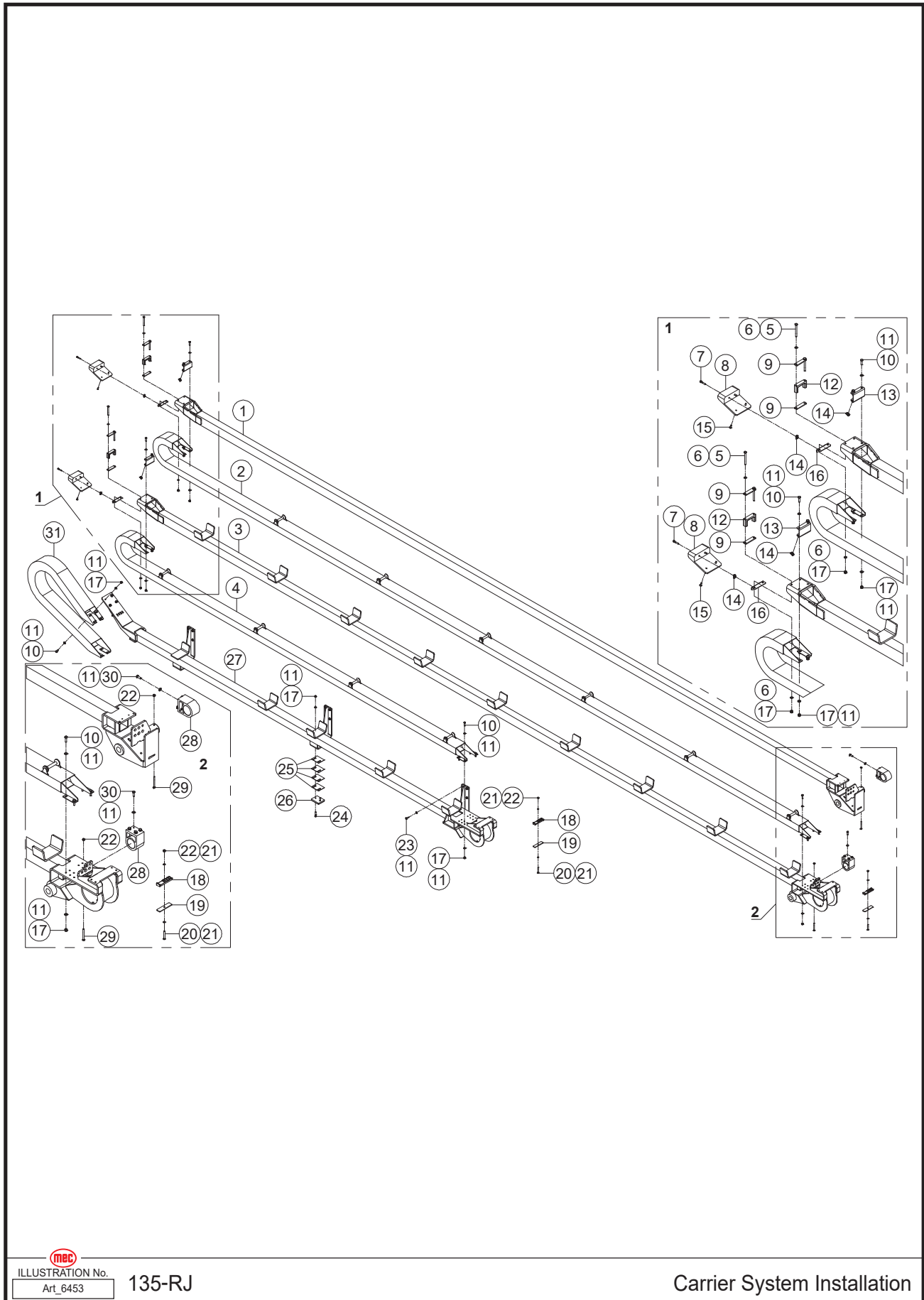



 ILLUSTRATION No. 135-RJ
Art_6452

Fourth Boom Cable Installation

Item	Part Number	Description	Qty.
1	60730	Bracket	4
2	60731	Bracket	4
3	60217	Set Screw M06-1.00 × 10 Cone Point ZP	4
4	60027	Screw SHCS M06-1.00 × 20 ZP	8
5	60064	Washer	2
6	60225	Nut NHEX M16-1.50 ZP	8
7	60704	Guide Plate	2
8	60148	Screw HHCS M08-1.25 × 50 ZP	4
9	47750	Spring Washer	4
10	60005	Screw SHCS M04-0.70 × 16 ZP	4
11	60650	Cable	2
12	50028	Screw HHCS M06-1.00 × 20 ZP	4
13	48186	Spring Washer	4
14	44736	Proximity Switch	2
15	60748	Bracket	2
16	60647	Bracket	1
17	60496	Disc Spring	2
18	60218	WSHR M16-2.00 Cone Face Washer ZP	2
19	60219	WSHR M16-2.00 Ball Face Washer ZP	2

Carrier System Installation



ILLUSTRATION No. 135-RJ
Art_6453

Carrier System Installation

Item	Part Number	Description	Qty.
1	49271	Support	1
2	49272	Chain	1
3	49273	Support	1
4	60475	Chain	1
5	60052	Screw HHCS M10-1.50 × 100 ZP	4
6	60012	WSHR M10 Standard Flat Washer ZP	8
7	60025	Screw SHCS M08-1.25 × 40 ZP	4
8	60541	Guide Plate	2
9	47980	Plate	4
10	60022	Screw HHCS M10-1.50 × 35 ZP	16
11	60444	Spring Washer	55
12	47981	Clamp	2
13	60540	Bracket	2
14	60171	No-Slip Clip-On Barrel Nut M08-1.25 ZP	8
15	53435	Screw CSCS M08-1.25 × 25 ZP	4
16	60539	Bracket	2
17	60017	Nut NNYL M10-1.50 ZP	22
18	47985	Chain	2
19	47984	Plate	2
20	60069	Screw HHCS M08-1.25 × 60 ZP	2
21	60008	WSHR M08 Standard Flat Washer ZP	4
22	60070	Nut NNYL M08-1.25 ZP	4
23	50033	Screw HHCS M10-1.50 × 25 ZP	12
24	60095	Screw SHCS M10-1.50 × 45 ZP	2
25	60787	Shim	4
26	60786	Block	1
27	49274	Support	1
28	60750	Bracket	2
29	60181	Screw HHCS M08-1.25 × 85 ZP	2
30	60021	Screw HHCS M10-1.50 × 30 ZP	9
31	60583	Chain	1

Carrier System Components

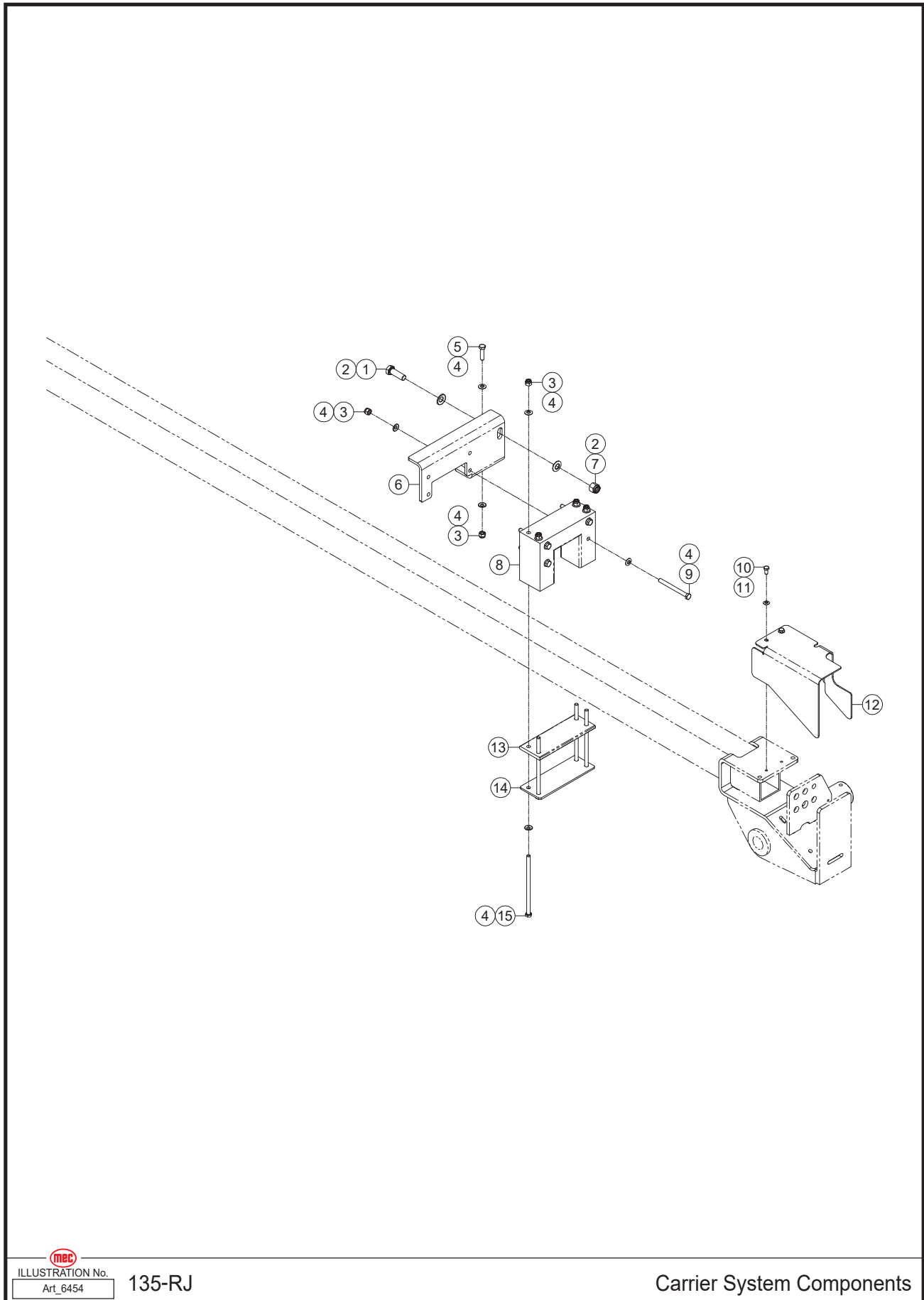
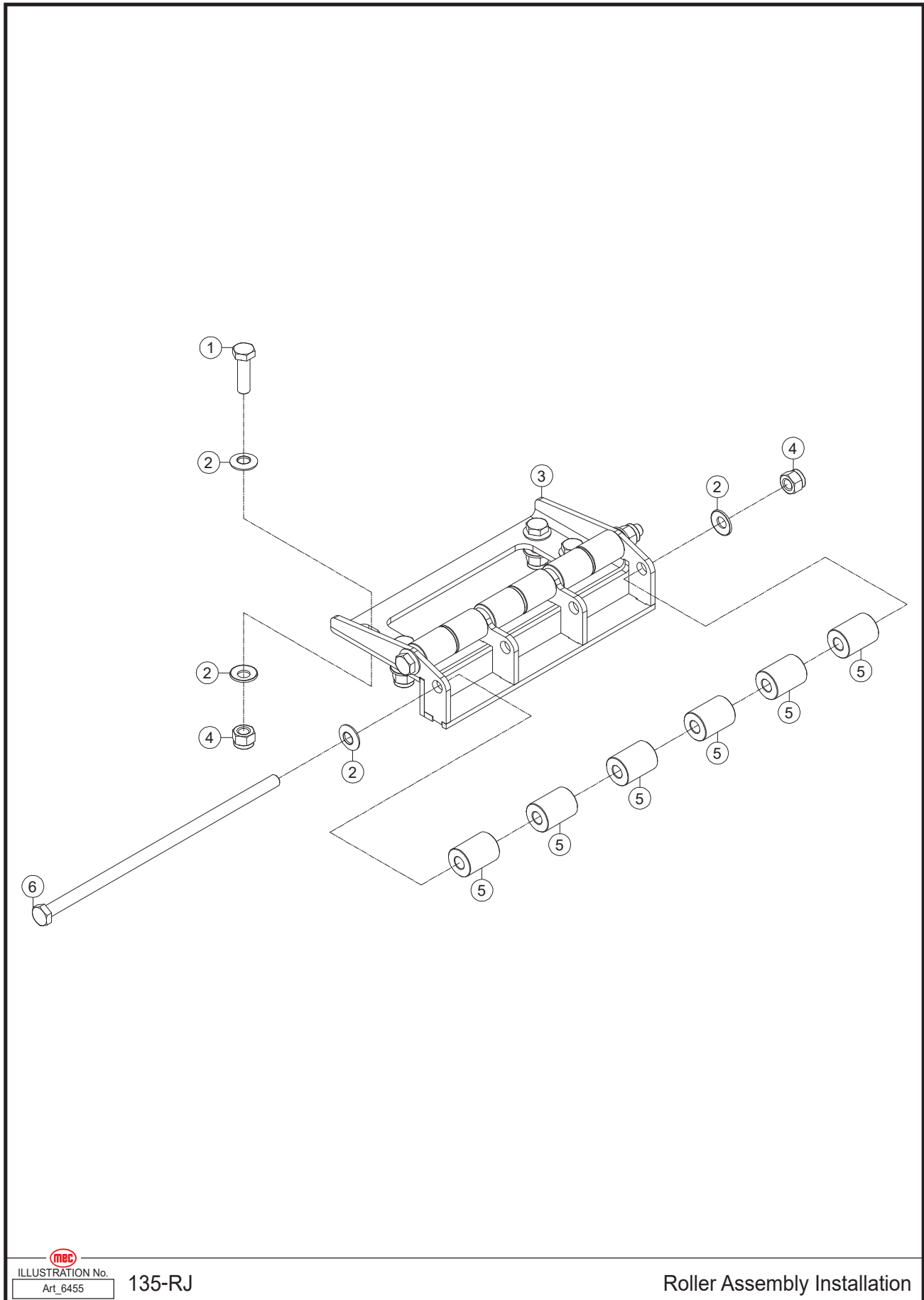



 ILLUSTRATION No. 135-RJ
Art_6454

Carrier System Components

Item	Part Number	Description	Qty.
1	60050	Screw HHCS M16-2.00 × 50 ZP	1
2	60840	Spring Washer	2
3	60017	Nut NNYL M10-1.50 ZP	9
4	60444	Spring Washer	18
5	60053	Screw HHCS M10-1.50 × 40 ZP	1
6	60760	Bracket	1
7	60077	Nut NNYL M16-2.00 ZP	1
8	60755	Guide Plate	1
9	60051	Screw HHCS M10-1.50 × 110 ZP	4
10	60063	Screw HHCS M08-1.25 × 16 ZP	3
11	47750	Spring Washer	3
12	60759	Housing	1
13	60758	Guide Plate	1
14	60764	Plate	1
15	60092	Screw HHCS M10-1.50 × 200 ZP	4

Roller Assembly Installation Part 1

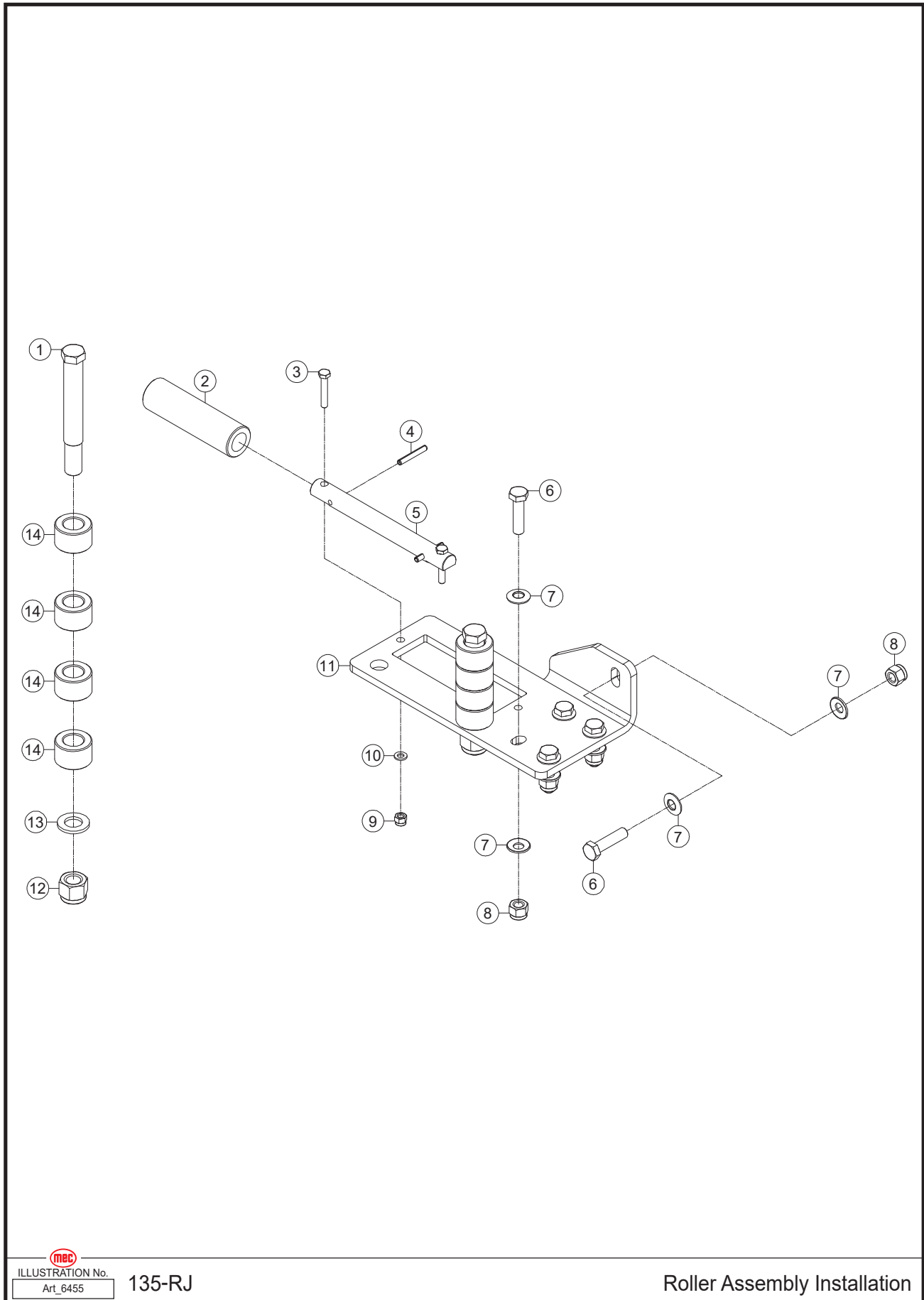



 ILLUSTRATION No. 135-RJ
Art_6455

Roller Assembly Installation

Item	Part Number	Description	Qty.
1	60022	Screw HHCS M10-1.50 × 35 ZP	4
2	60444	Spring Washer	12
3	60543	Bracket	1
4	60017	Nut NNYL M10-1.50 ZP	6
5	60542	Roller	12
6	60250	Screw HHCS M10-1.50 × 260 ZP	2

Roller Assembly Installation Part 2

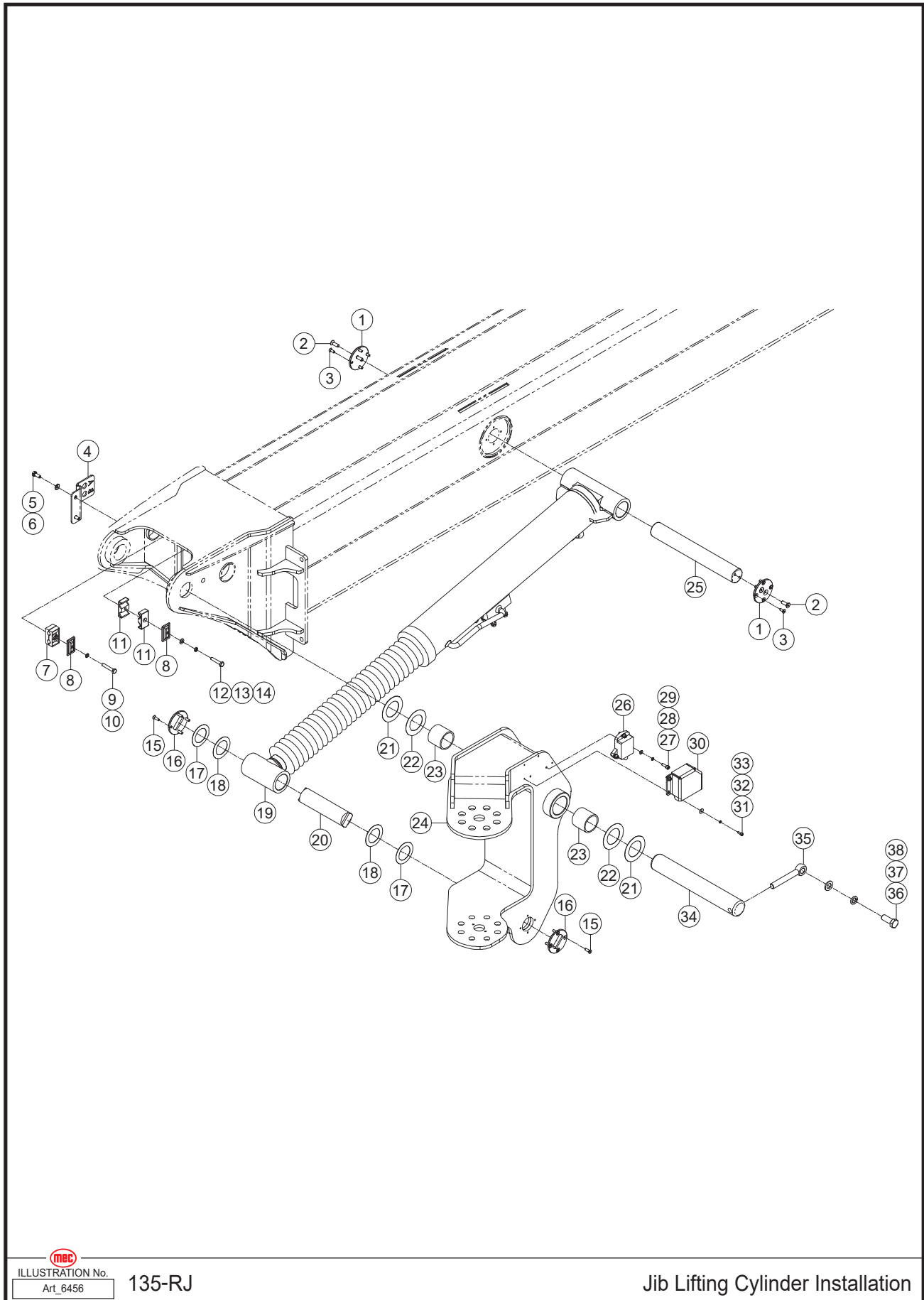



 ILLUSTRATION No. 135-RJ
Art_6455

Roller Assembly Installation

Item	Part Number	Description	Qty.
1	60442	Bolt	2
2	60439	Roller	1
3	60140	Screw HHCS M06-1.00 × 35 ZP	2
4	60110	Cotter Pin	2
5	60440	Rod	1
6	60053	Screw HHCS M10-1.50 × 40 ZP	5
7	60444	Spring Washer	10
8	60017	Nut NNYL M10-1.50 ZP	5
9	60048	Nut NNYL M06-1.00 ZP	2
10	60015	WSHR M06 Standard Flat Washer ZP	2
11	60505	Bracket	1
12	60077	Nut NNYL M16-2.00 ZP	2
13	60045	WSHR M16 Standard Flat Washer ZP	2
14	60441	Roller	8

Jib Lifting Cylinder Installation



 ILLUSTRATION No. 135-RJ
Art_6456

Jib Lifting Cylinder Installation

Item	Part Number	Description	Qty.
1	49275	Cover	2
2	53435	Screw CSCS M08-1.25 × 25 ZP	4
3	60035	Screw CSCS M06-1.00 × 16 ZP	8
4	60744	Bracket	1
5	50030	Screw HHCS M08-1.25 × 20 ZP	2
6	47750	Spring Washer	2
7	41416	Clamp	1
8	47999	Plate	2
9	60134	Screw HHCS M08-1.25 × 45 ZP	1
10	60841	Spring Washer	1
11	47864	Clamp	2
12	60133	Screw HHCS M08-1.25 × 40 ZP	1
13	60009	WSHR M08 Spring Washer ZP	1
14	60008	WSHR M08 Standard Flat Washer ZP	1
15	60036	Screw CSCS M06-1.00 × 20 ZP	8
16	49276	Cover	2
17	49277	Shim	2
18	49278	Shim	2
19	REF	Jib Leveling Cylinder Assembly (Refer to page 206)	1
20	49279	Pin, Pivot	1
21	47861	Shim	2
22	47860	Shim	2
23	47554	Sleeve Bearing	2
24	49280	Junction	1
25	49281	Pin, Pivot	1
26	45455	Angle Sensor	1
27	60027	Screw SHCS M06-1.00 × 20 ZP	3
28	53046	WSHR M06 Spring Washer ZP	3
29	60015	WSHR M06 Standard Flat Washer ZP	3
30	49282	Housing	1
31	60076	Screw SHCS M05-0.80 × 12 ZP	3
32	60007	WSHR M05 Spring Washer ZP	3
33	50525	WSHR M05 Flat Fender Washer ZP	3
34	49283	Pin, Pivot	1
35	60002	Pin, Lock	1
36	60068	Screw HHCS M16-2.00 × 40 ZP	1
37	60049	WSHR M16 Spring Washer ZP	1
38	60045	WSHR M16 Standard Flat Washer ZP	1

REF – Reference

Rotating Jib Installation

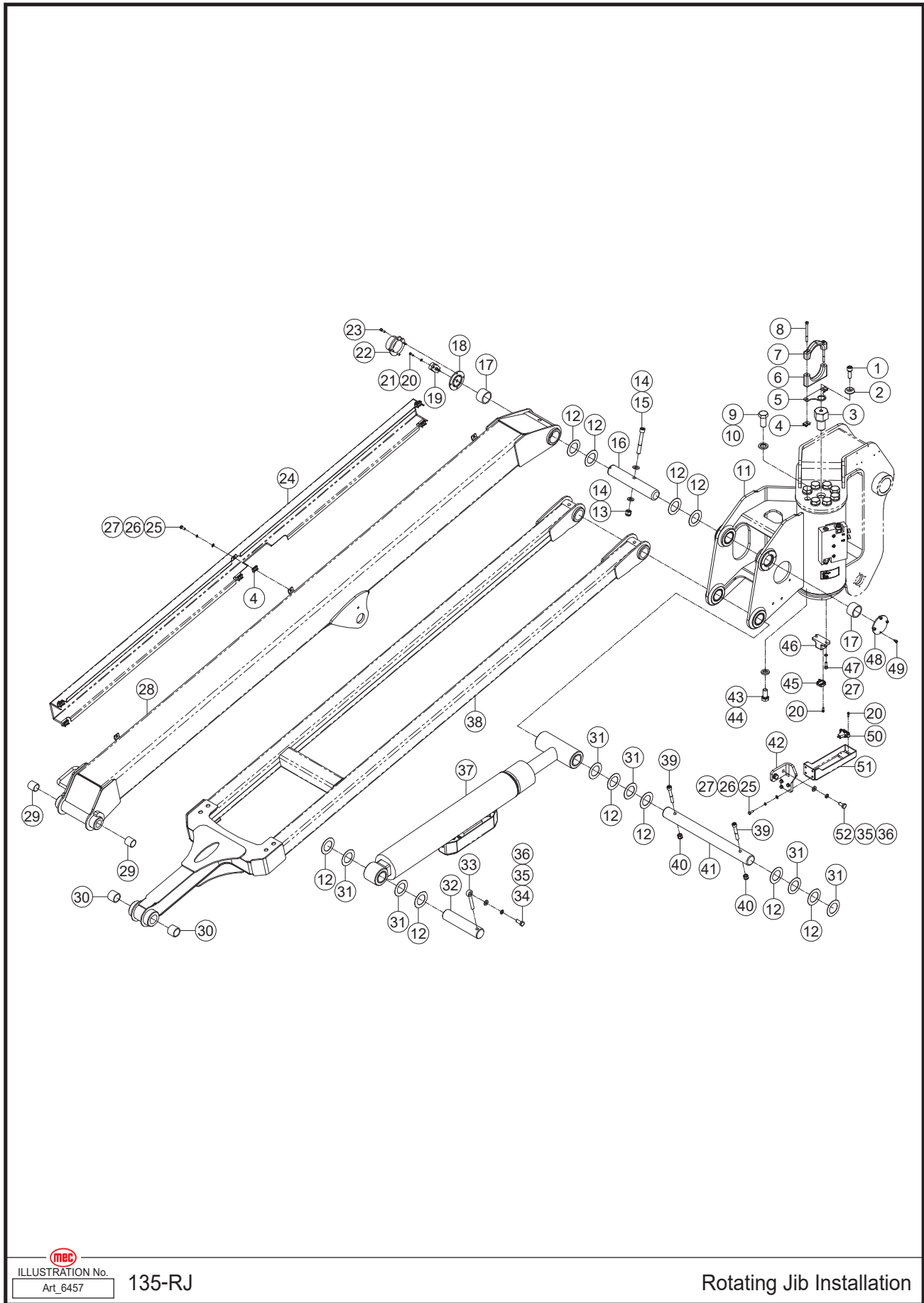

 ILLUSTRATION No. 135-RJ
Art_6457

Rotating Jib Installation

Item	Part Number	Description	Qty.
1	60174	Screw SHCS M12-1.75 × 35 ZP	1
2	49284	Support	1
3	49285	Bolt	1
4	53481	No-Slip Clip-On Barrel Nut M06-1.00 ZP	8
5	49286	Support	1
6	49287	Clamp	1
7	49288	Clamp	1
8	60941	Screw CSCS M06-1.00 × 80 ZP	2
9	53576	Screw HHCS M20-2.50 × 45 ZP	8
10	47601	Flat Washer	8
11	49289	Rotate Cylinder Assembly	1
12	60425	Shim	10
13	60074	Nut NNYL M12-1.75 ZP	1
14	60031	WSHR M12 Standard Flat Washer ZP	2
15	60103	Screw SHCS M12-1.75 × 90 ZP	1
16	49290	Pin, Pivot	1
17	60414	Sleeve Bearing	2
18	49291	Plate	1
19	41195	Sensor, Rotary	1
20	60059	Screw SHCS M04-0.70 × 12 ZP	6
21	60029	WSHR M04 Standard Flat Washer ZP	2
22	60400	Housing	1
23	60073	Screw SHCS M05-0.80 × 16 ZP	4
24	49292	Channel	1
25	50445	Screw HHCS M06-1.00 × 16 ZP	10
26	53046	WSHR M06 Spring Washer ZP	10
27	60015	WSHR M06 Standard Flat Washer ZP	12
28	49293	Linker, Upper	1
29	46549	Sleeve Bearing	2
30	60417	Sleeve Bearing	2
31	60424	Shim	6
32	49294	Pin, Pivot	1
33	41431	Pin, Lock	1
34	50033	Screw HHCS M10-1.50 × 25 ZP	1
35	60020	WSHR M10 Spring Washer ZP	3
36	60012	WSHR M10 Standard Flat Washer ZP	3
37	REF	Jib Lifting Cylinder Assembly (Refer to page 208)	1
38	49295	Linker, Lower	1
39	60128	Screw SHCS M10-1.50 × 70 ZP	2
40	60017	Nut NNYL M10-1.50 ZP	2
41	60423	Pin, Pivot	1
42	49296	Bracket	1
43	60208	Screw HHCS M16-2.00 × 35 ZP	8
44	60064	Flat Washer	8

45	60653	Angle Sensor Actuator	1
46	49297	Bracket	1
47	60027	Screw SHCS M06-1.00 × 20 ZP	2
48	60402	Cover	1
49	53552	Screw SHCS M05-0.80 × 8 ZP	4
50	60618	Angle Sensor	1
51	49298	Housing	1
52	60019	Screw HHCS M10-1.50 × 20 ZP	2

REF – Reference

THIS PAGE HAS BEEN INTENTIONALLY LEFT BLANK

Platform Rotator Installation

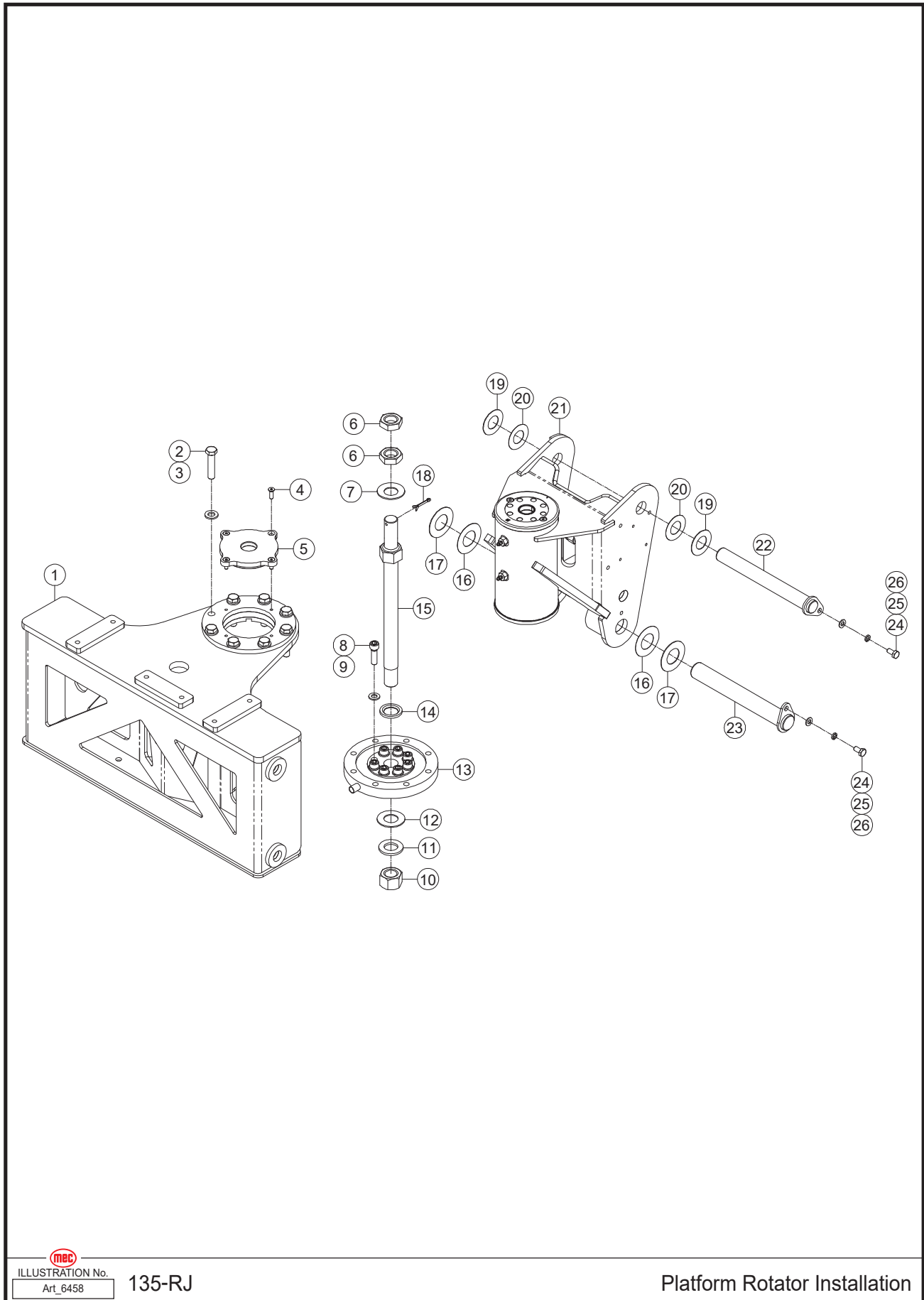
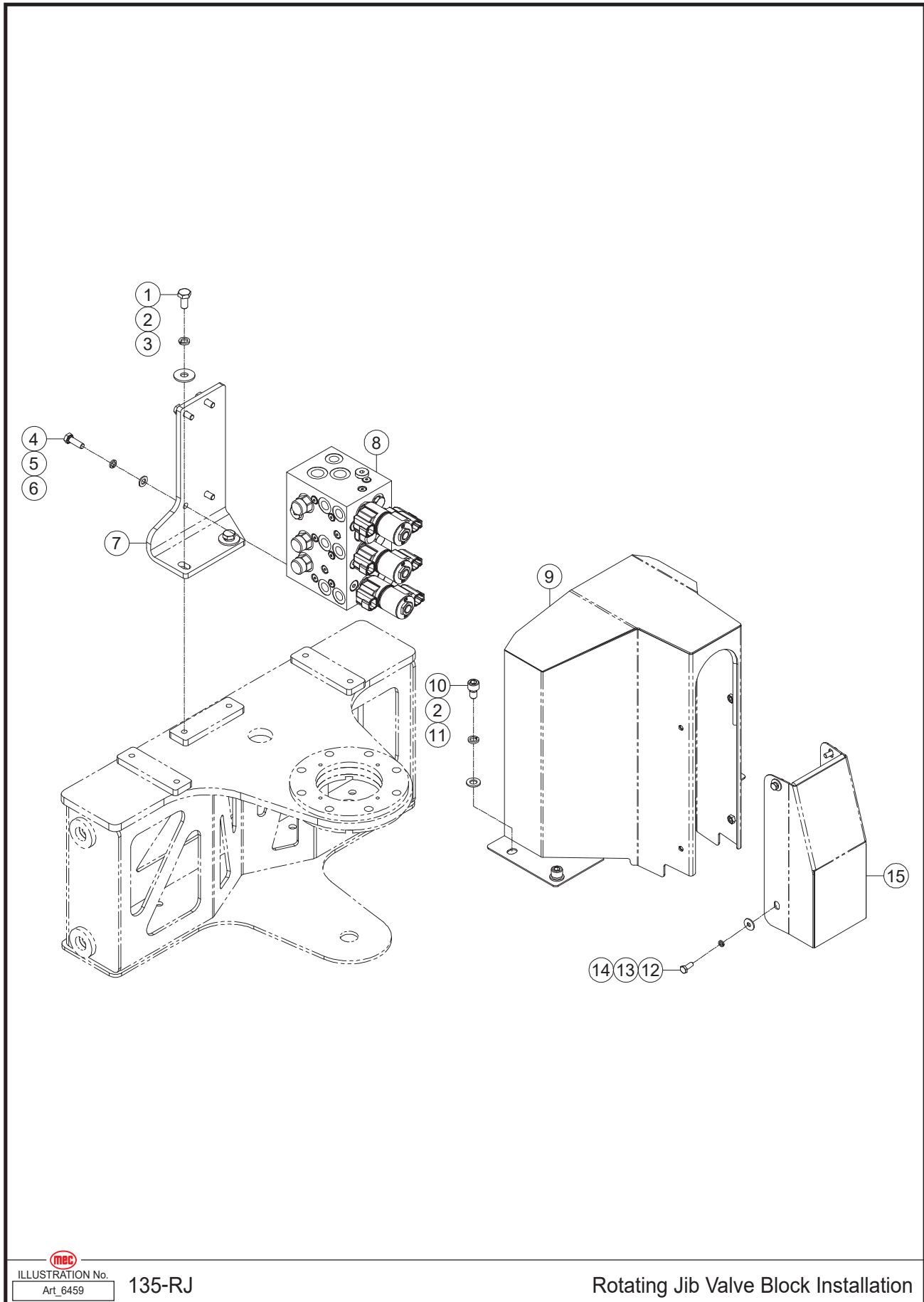



ILLUSTRATION No. 135-RJ
Art_6458

Platform Rotator Installation

Item	Part Number	Description	Qty.
1	45491	Support	1
2	60142	Screw HHCS M12-1.75 × 55 ZP	8
3	60031	WSHR M12 Standard Flat Washer ZP	8
4	60036	Screw CSCS M06-1.00 × 20 ZP	4
5	45450	Cover	1
6	53571	Nut NHEX M24-2.00, Thin Nut Chamfered ZP	2
7	45451	Disc Spring	1
8	60109	Screw SHCS M10-1.50 × 35 ZP	8
9	60012	WSHR M10 Standard Flat Washer ZP	8
10	53572	Nut NHEX M24-2.00 ZP	1
11	60067	WSHR M24 Standard Flat Washer ZP	1
12	45459	Shim	1
13	45458	Load Sensor	1
14	45457	Washer	1
15	45456	Pin, Pivot	1
16	60418	Shim	2
17	60419	Shim	2
18	41322	Cotter Pin	1
19	60425	Shim	2
20	60425	Shim	2
21	60413	Rotate Cylinder Assembly	1
22	60420	Pin, Pivot	1
23	60421	Pin, Pivot	1
24	60063	Screw HHCS M08-1.25 × 16 ZP	2
25	60009	WSHR M08 Spring Washer ZP	2
26	60008	WSHR M08 Standard Flat Washer ZP	2

Rotating Jib Valve Block Installation

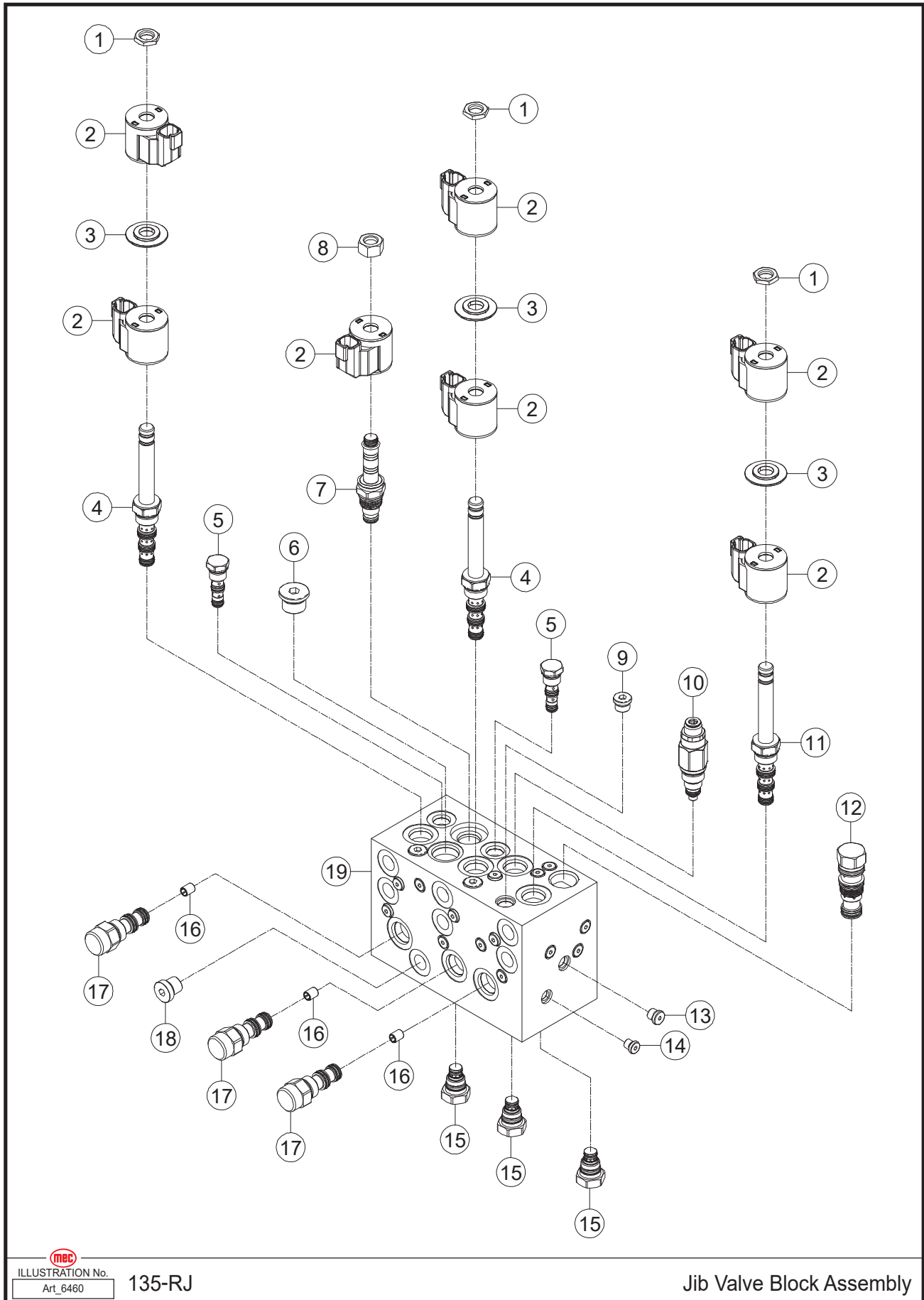



 ILLUSTRATION No. 135-RJ
Art_6459

Rotating Jib Valve Block Installation

Item	Part Number	Description	Qty.
1	60019	Screw HHCS M10-1.50 × 20 ZP	2
2	60020	WSHR M10 Spring Washer ZP	6
3	53375	WSHR M10 Flat Fender Washer ZP	2
4	60043	Screw HHCS M08-1.25 × 25 ZP	4
5	60009	WSHR M08 Spring Washer ZP	4
6	60008	WSHR M08 Standard Flat Washer ZP	4
7	49299	Bracket	1
8	49300	Jib Valve Block Assembly (Refer to page 188)	1
9	45462	Housing	1
10	53573	Screw SHCS M10-1.50 × 16 ZP	4
11	60012	WSHR M10 Standard Flat Washer ZP	4
12	50445	Screw HHCS M06-1.00 × 16 ZP	4
13	53046	WSHR M06 Spring Washer ZP	4
14	50068	WSHR M06 Flat Fender Washer ZP	4
15	45463	Housing	1

Jib Valve Block Assembly

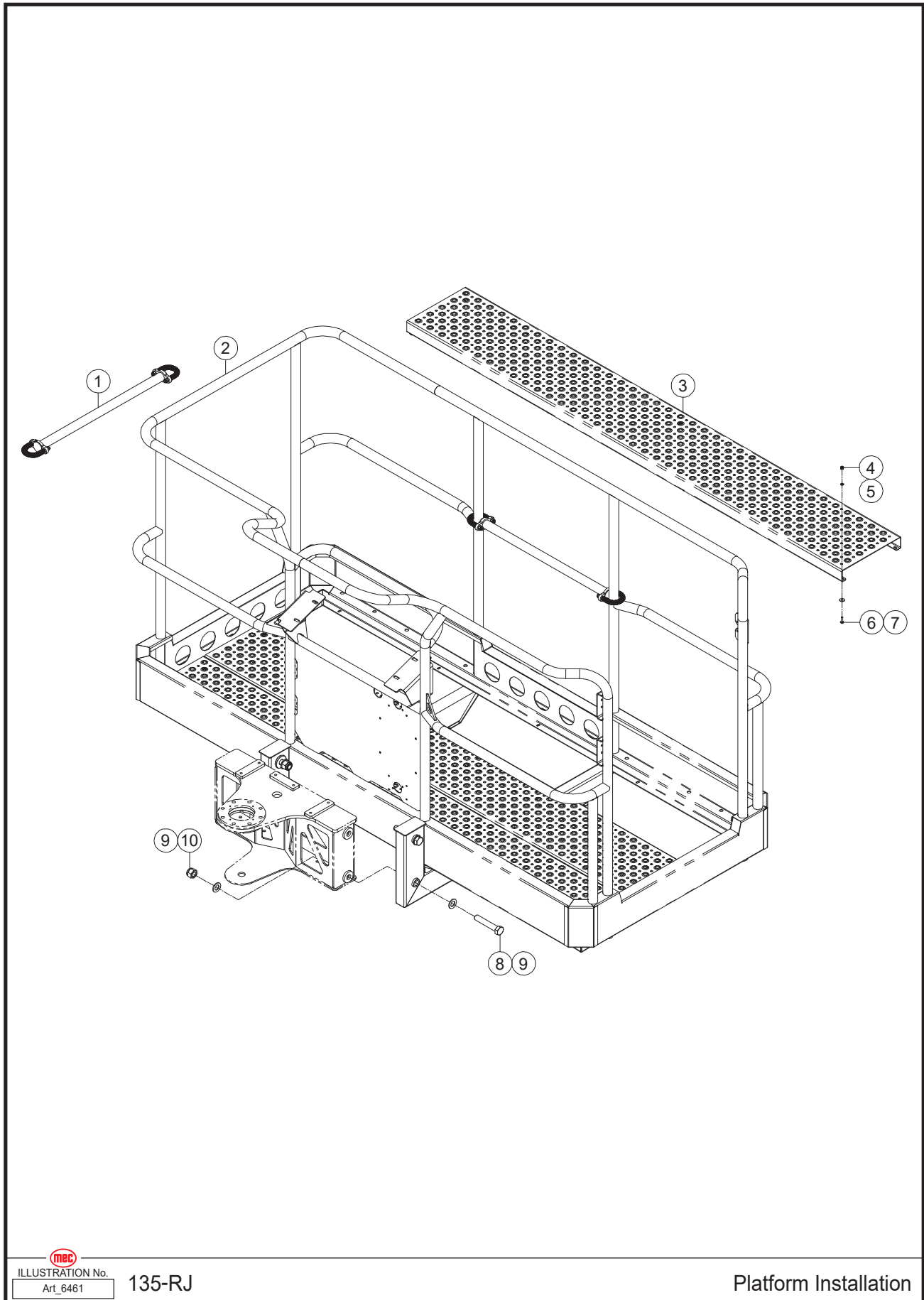



 ILLUSTRATION No. 135-RJ
Art_6460

Jib Valve Block Assembly

Item	Part Number	Description	Qty.
1	42795	Nut	3
2	47741	Coil	7
3	60184	Spacer	3
4	60182	Cartridge, Proportional Solenoid Valve	2
5	60194	Cartridge, Shuttle Valve	2
6	60153	Plug	1
7	60116	Cartridge, Solenoid Valve	1
8	60185	Nut	1
9	42802	Plug	3
10	49301	Cartridge, Relief Valve	1
11	49302	Cartridge, Proportional Solenoid Valve	1
12	49303	Cartridge, Shuttle Valve	1
13	43643	Plug	1
14	43465	Plug	25
15	49304	Cartridge, Check Valve	3
16	49305	Orifice	3
17	60180	Cartridge, Logic Valve	3
18	42480	Plug	1
19	49306	Body	1

Platform Installation



 ILLUSTRATION No. 135-RJ
Art_6461

Platform Installation

Item	Part Number	Description	Qty.
1	REF	Lift Gate Assembly (Refer to page 194)	2
2	45470	Platform	1
3	45471	Deck Plate	3
4	60048	Nut NNYL M06-1.00 ZP	34
5	60015	WSHR M06 Standard Flat Washer ZP	34
6	50028	Screw HHCS M06-1.00 × 20 ZP	34
7	50068	WSHR M06 Flat Fender Washer ZP	34
8	53002	Screw HHCS M20-2.50 × 110 ZP	4
9	50005	WSHR M20 Standard Flat Washer ZP	8
10	50052	Nut NNYL M20-2.50 ZP	4

REF – Reference

Entry Gate Assembly

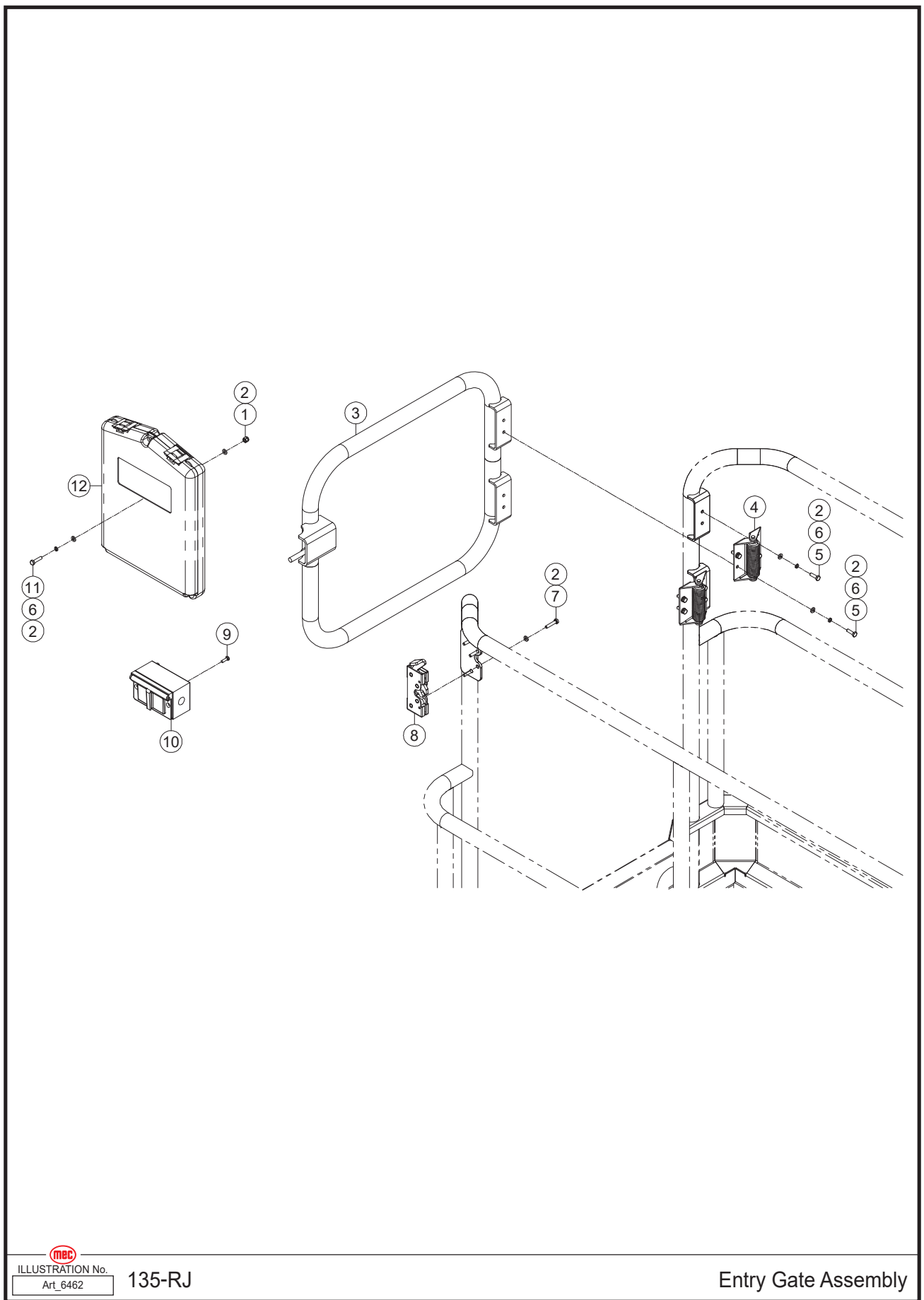

 ILLUSTRATION No. 135-RJ
Art_6462

Entry Gate Assembly

Item	Part Number	Description	Qty.
1	60048	Nut NNYL M06-1.00 ZP	4
2	60015	WSHR M06 Standard Flat Washer ZP	20
3	45472	Side Swing Gate Assembly	1
4	44764	Hinge	2
5	50028	Screw HHCS M06-1.00 × 20 ZP	8
6	53046	WSHR M06 Spring Washer ZP	12
7	60028	Screw HHCS M06-1.00 × 30 ZP	4
8	41067	Lock	1
9	53351	Screw PHMS M05-0.80 × 16 ZP	4
10	42613	Electrical Outlet	1
11	60014	Screw HHCS M06-1.00 × 25 ZP	4
12	43319	Box, Manual	1

Lift Gate Assembly

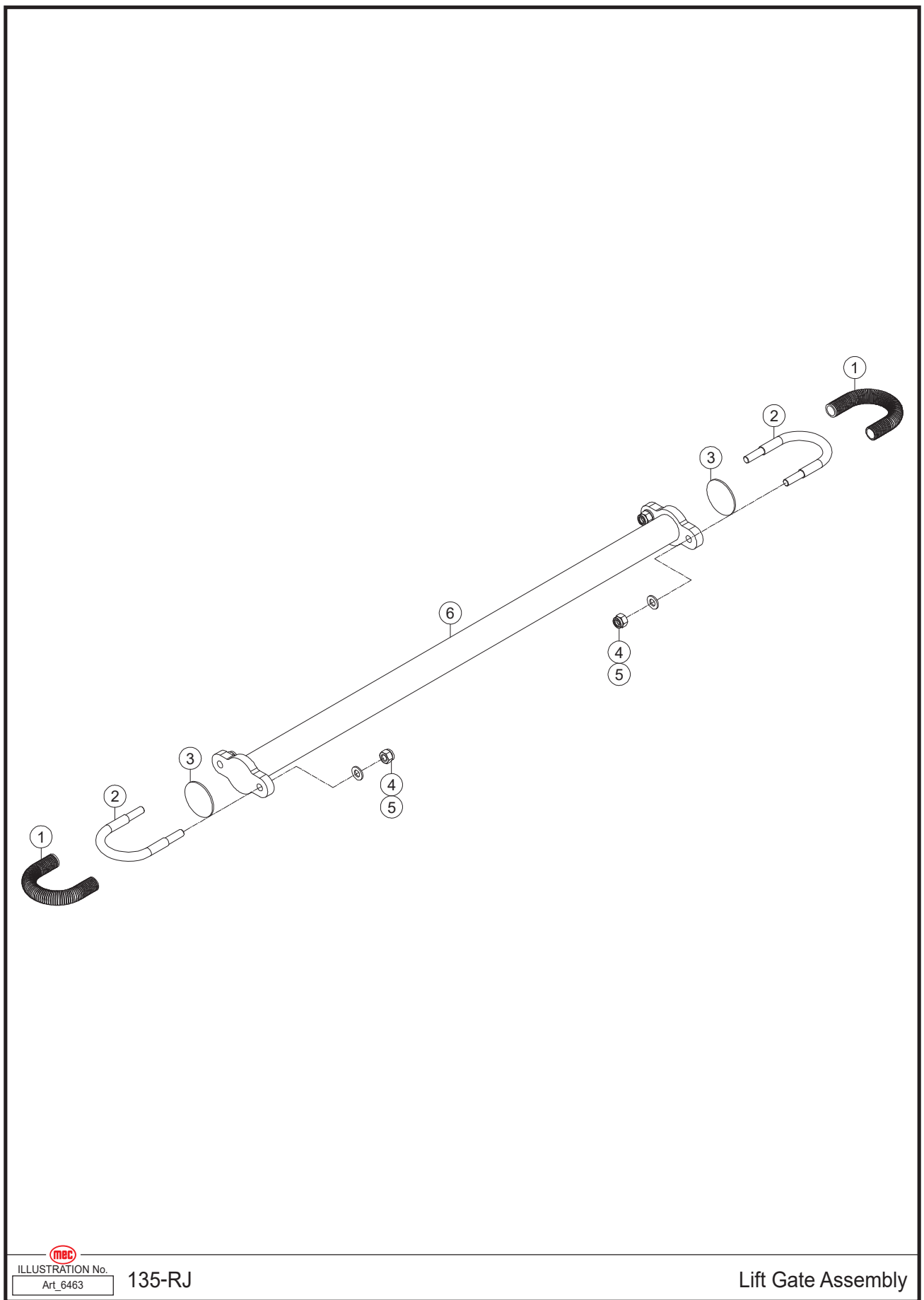

 ILLUSTRATION No. 135-RJ
Art_6463

Lift Gate Assembly

Item	Part Number	Description	Qty.
1	45476	Jacket	2
2	45477	Clamp	2
3	45478	Anti-Scratch Guard	2
4	60070	Nut NNYL M08-1.25 ZP	4
5	60008	WSHR M08 Standard Flat Washer ZP	4
6	45479	Gate, Lift	1

Secondary Guarding Bar Assembly

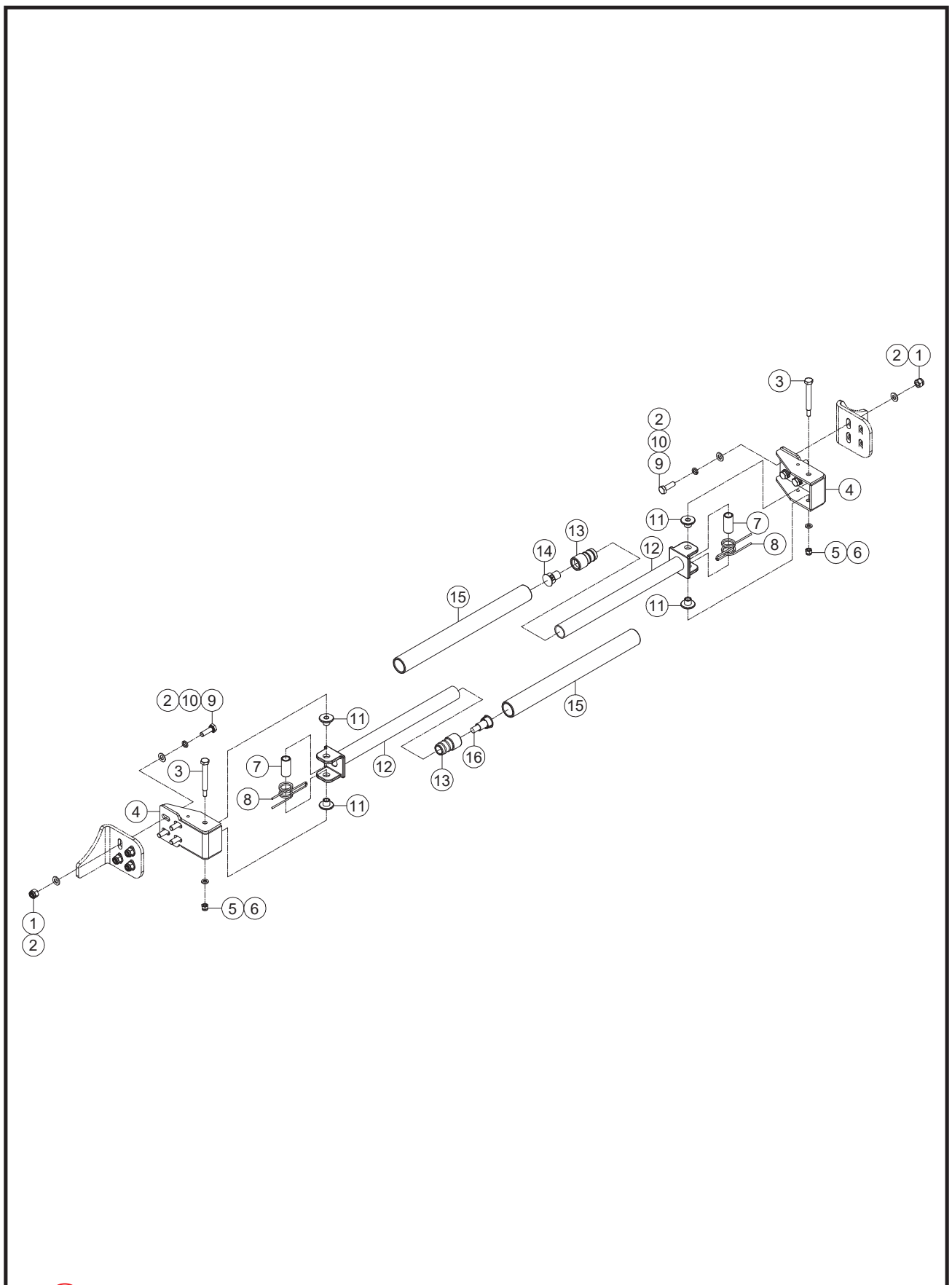
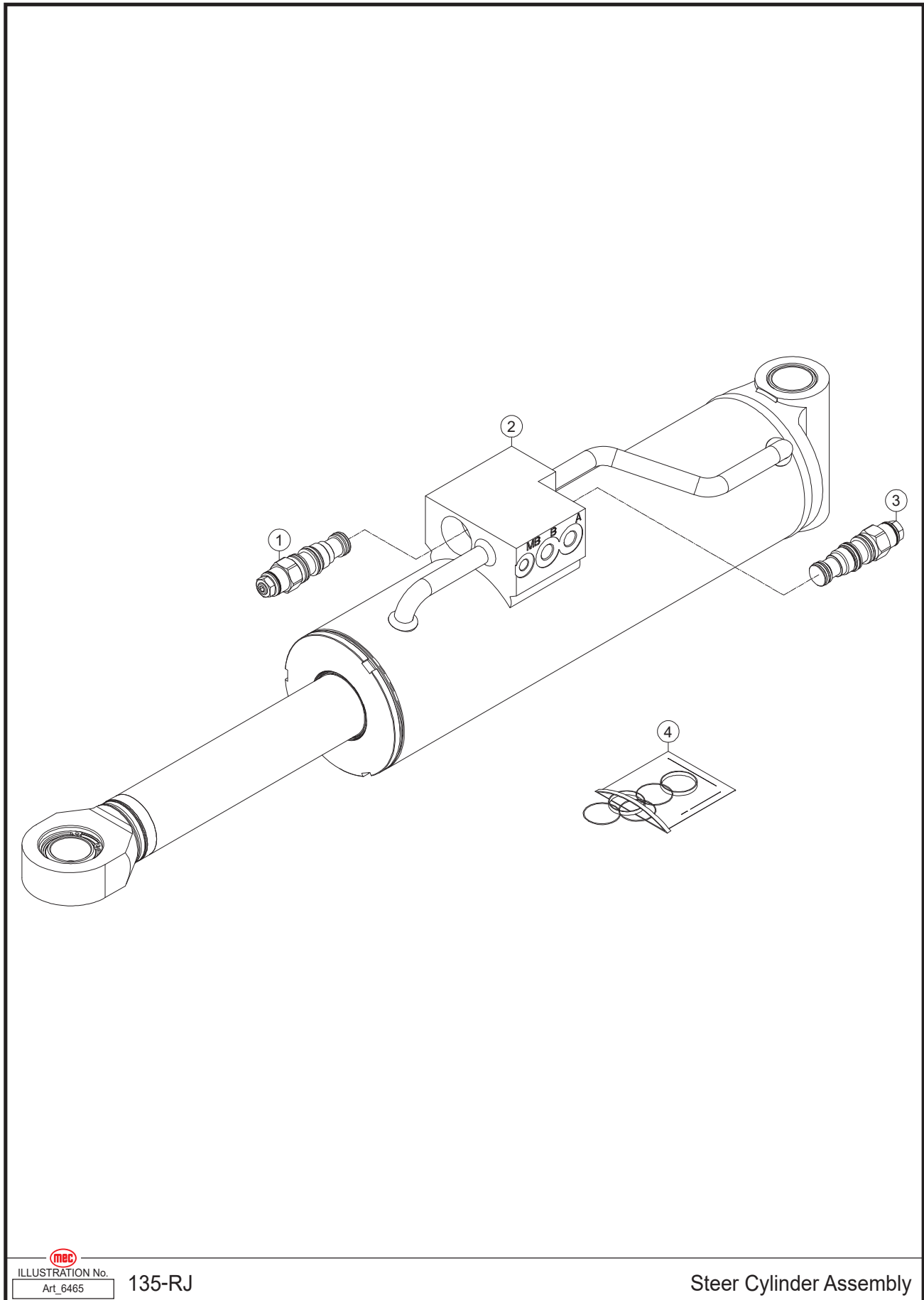



 ILLUSTRATION No. 135-RJ
Art_6464

Secondary Guarding Bar Assembly

Item	Part Number	Description	Qty.
1	60070	Nut NNYL M08-1.25 ZP	8
2	60008	WSHR M08 Standard Flat Washer ZP	16
3	45480	Pin	2
4	45490	Bracket, Contact Alarm	2
5	60048	Nut NNYL M06-1.00 ZP	2
6	60015	WSHR M06 Standard Flat Washer ZP	2
7	45482	Tube	2
8	45483	Spring	2
9	60043	Screw HHCS M08-1.25 × 25 ZP	8
10	60009	WSHR M08 Spring Washer ZP	8
11	45484	Bearing	4
12	45485	Tube, Contact Alarm	2
13	45486	Plug, Nylon	2
14	45487	Magnet	1
15	45488	Jacket, Foam	2
16	45489	Door Magnetic Switch	1

Steer Cylinder Assembly

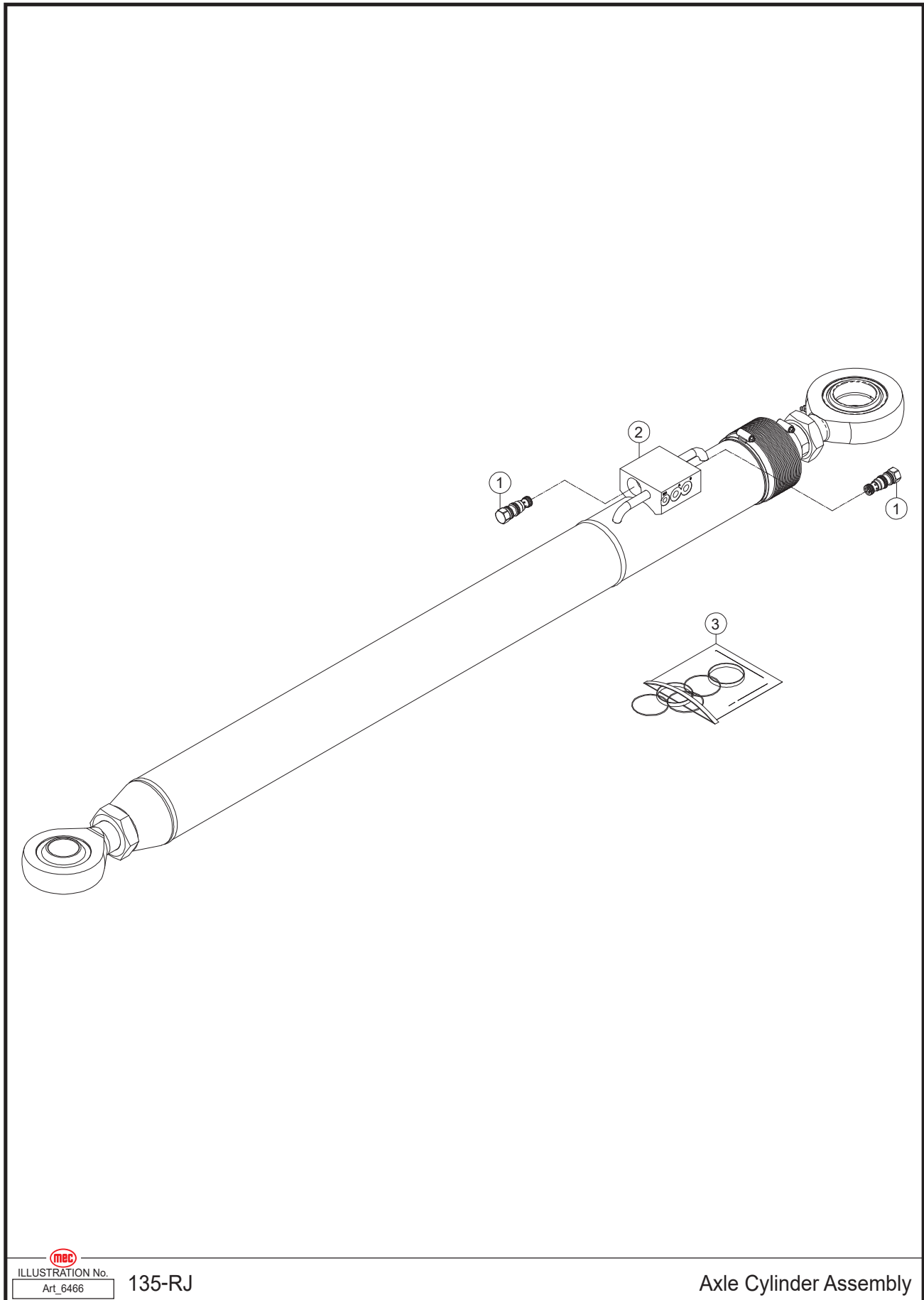



ILLUSTRATION No. 135-RJ
Art_6465

Steer Cylinder Assembly

Item	Part Number	Description	Qty.
1	60503	Cartridge, Valve (Counterbalance)	1
2	60611	Steer Cylinder Assembly	1
3	60471	Cartridge, Valve (Counterbalance)	1
4	60533	Seal Kit	1

Axle Cylinder Assembly



ILLUSTRATION No. 135-RJ
Art_6466

Axle Cylinder Assembly

Item	Part Number	Description	Qty.
1	60470	Check Valve	2
2	49307	Axle Extend Cylinder Assembly	1
3	60535	Seal Kit	1

Lifting Cylinder Assembly

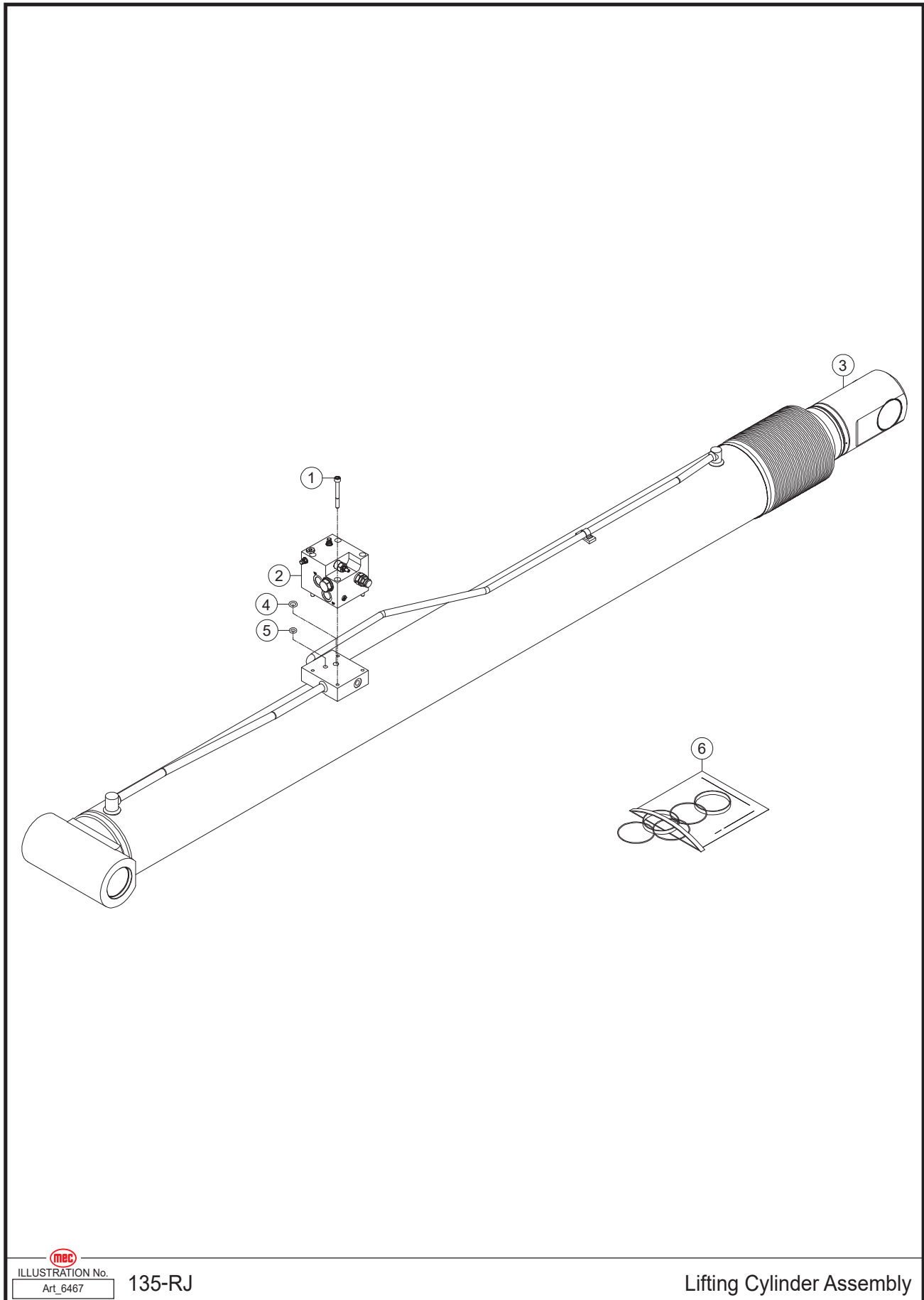

 ILLUSTRATION No. 135-RJ
Art_6467

Lifting Cylinder Assembly

Item	Part Number	Description	Qty.
1	60145	Screw SHCS M10-1.50 × 90 ZP	4
2	60504	Counterbalance Valve	1
3	60553	Lifting Cylinder Assembly	1
4	60082	O-Ring	1
5	60081	O-Ring	1
6	60536	Seal Kit	1

Telescopic Cylinder Assembly

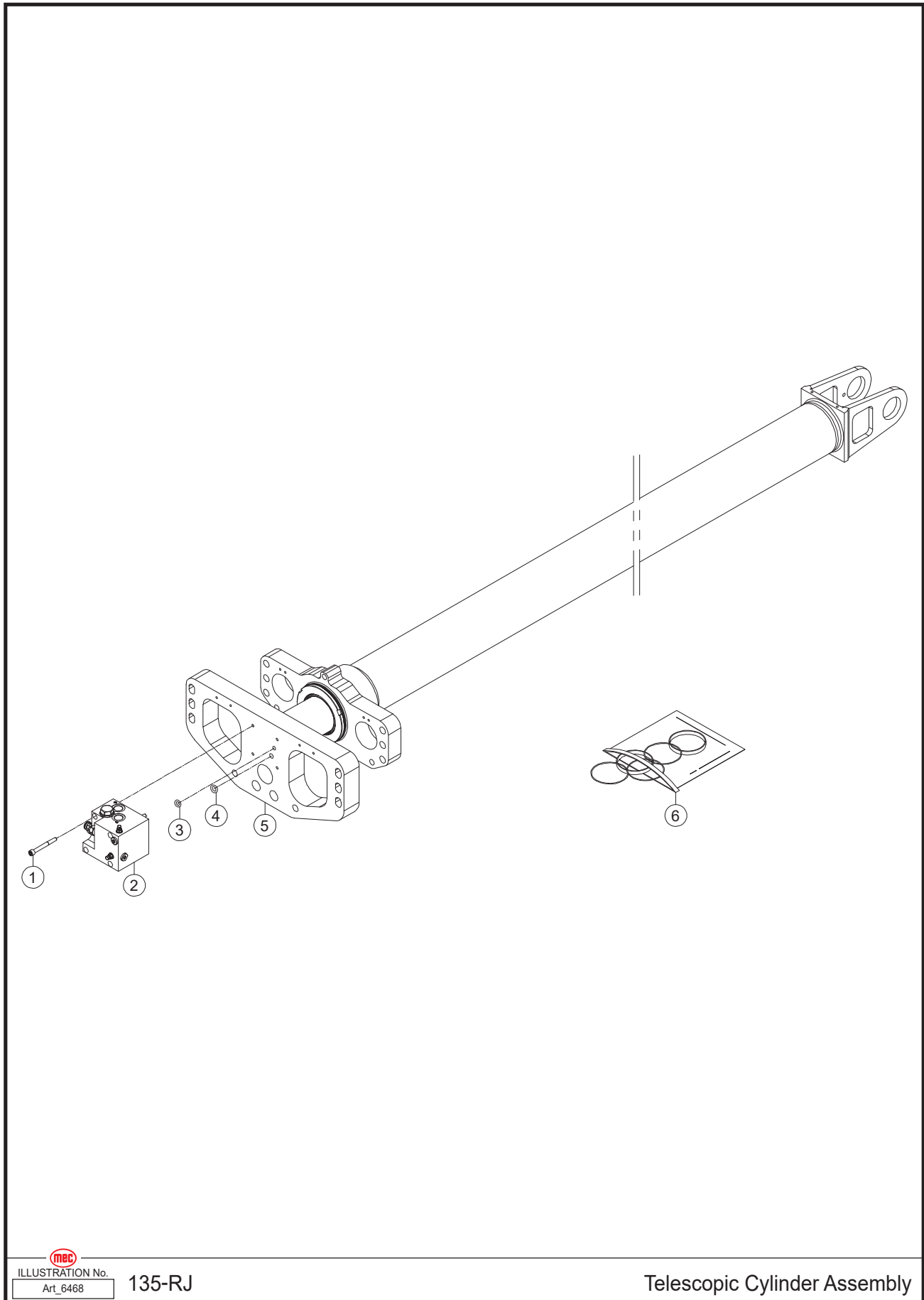
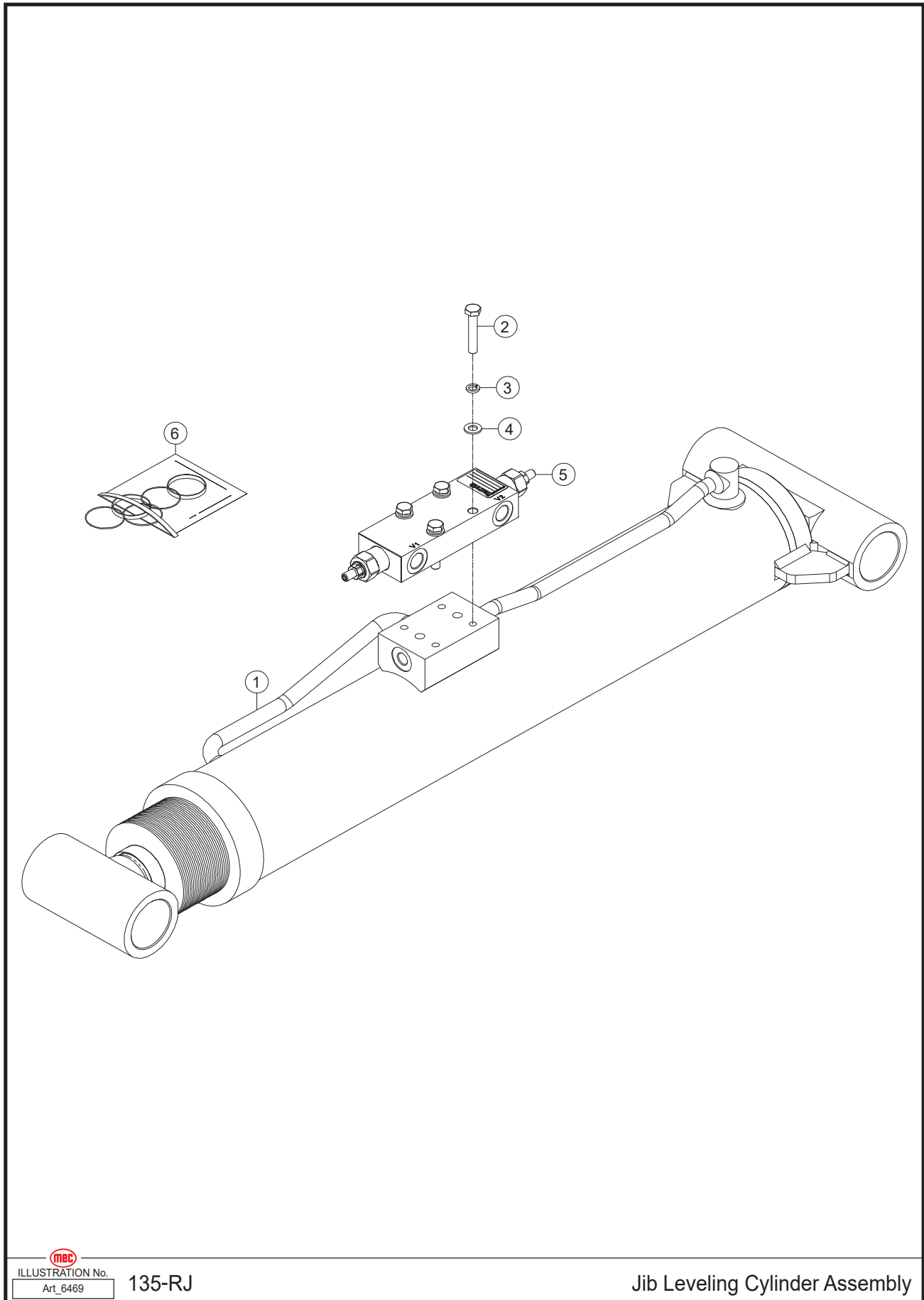



 ILLUSTRATION No. 135-RJ
Art_6468

Telescopic Cylinder Assembly

Item	Part Number	Description	Qty.
1	60145	Screw SHCS M10-1.50 × 90 ZP	4
2	60504	Counterbalance Valve	1
3	60081	O-Ring	1
4	60082	O-Ring	1
5	49308	Telescopic Cylinder Assembly	1
6	60534	Seal Kit	1

Jib Leveling Cylinder Assembly

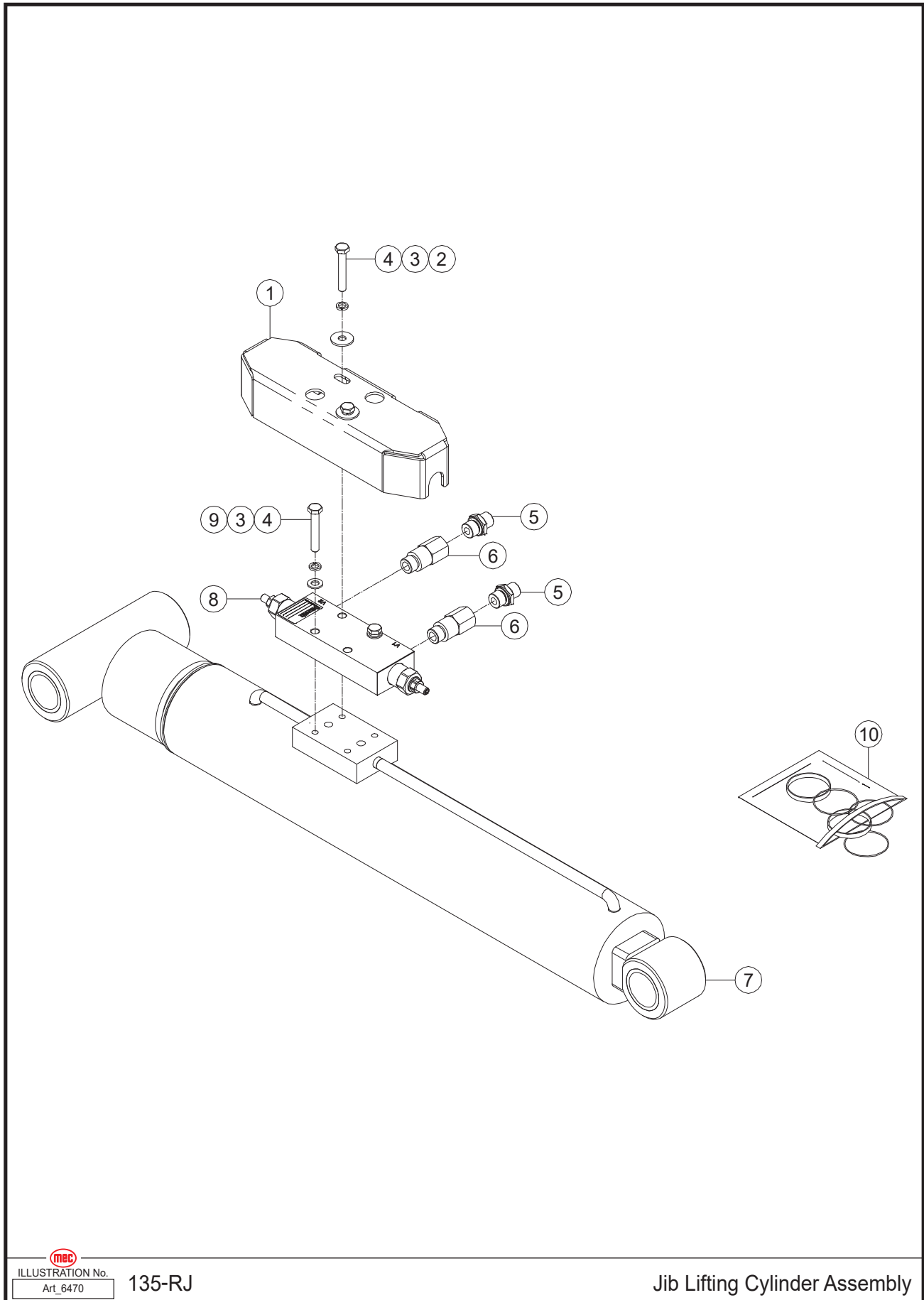



 ILLUSTRATION No. 135-RJ
Art_6469

Jib Leveling Cylinder Assembly

Item	Part Number	Description	Qty.
1	49309	Jib Leveling Cylinder Assembly	1
2	60134	Screw HHCS M08-1.25 × 45 ZP	4
3	60009	WSHR M08 Spring Washer ZP	4
4	60008	WSHR M08 Standard Flat Washer ZP	4
5	45514	Valve	1
6	60432	Seal Kit	1

Jib Lifting Cylinder Assembly

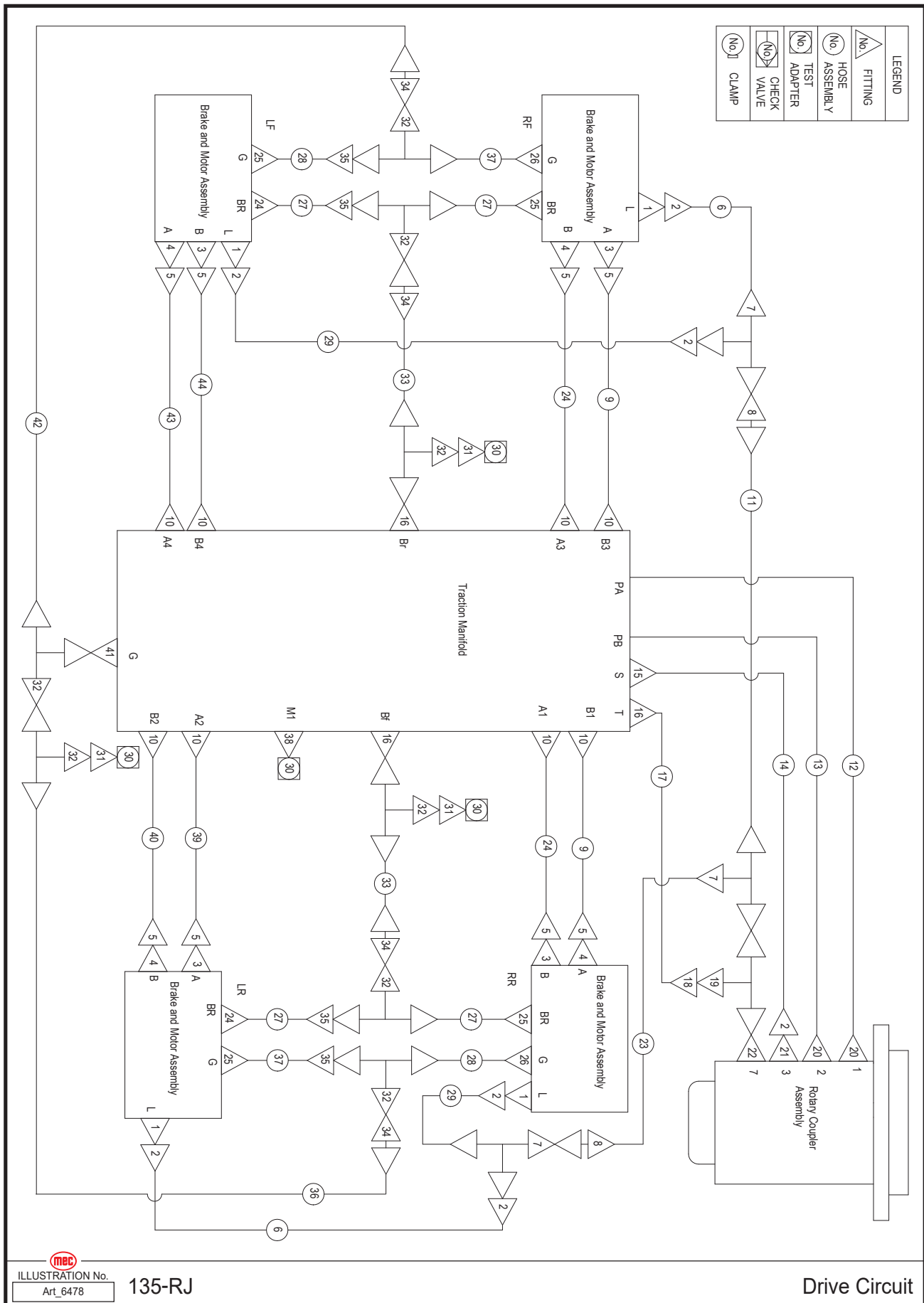



ILLUSTRATION No. 135-RJ
Art_6470

Jib Lifting Cylinder Assembly

Item	Part Number	Description	Qty.
1	60428	Housing	1
2	60090	WSHR M08 Flat Fender Washer ZP	2
3	60009	WSHR M08 Spring Washer ZP	4
4	60148	Screw HHCS M08-1.25 × 50 ZP	4
5	48913	Fitting, Straight	2
6	60416	Fitting, Straight	2
7	60426	Jib Lifting Cylinder Assembly	1
8	60431	Valve	1
9	60008	WSHR M08 Standard Flat Washer ZP	2
10	60432	Seal Kit	1

Drive Circuit



Drive Circuit

Item	Part Number	Description	Qty.
1	43205	Fitting, Straight	4
2	43206	Fitting, 90°	7
3	53437	Fitting, Straight, Lengthening	4
4	43039	Fitting, Straight	4
5	43040	Fitting, 90°	8
6	49310	Hose Assembly	2
7	43117	Fitting, Tee	3
8	43657	Fitting, Straight, Bulkhead	2
9	49311	Hose Assembly	2
10	60220	Fitting, Flange	8
--	48949	SAE Flange Fitting	8
--	60842	Spring Washer	32
--	60109	Screw SHCS M10-1.50 × 35 ZP	32
11	60334	Hose Assembly	1
12	60326	Hose Assembly	1
--	48949	SAE Flange Fitting	2
--	60842	Spring Washer	8
--	60109	Screw SHCS M10-1.50 × 35 ZP	8
13	60327	Hose Assembly	1
--	48949	SAE Flange Fitting	2
--	60842	Spring Washer	8
--	60109	Screw SHCS M10-1.50 × 35 ZP	8
14	60328	Hose Assembly	1
15	43582	Fitting, Straight	1
16	60080	Fitting, Straight	3
17	60332	Hose Assembly	1
18	60167	Fitting, Straight, Red	1
19	60099	Fitting, Tee	1
20	45563	Fitting, Straight	2
21	48399	Fitting, Straight	1
22	45529	Fitting, Straight	1
23	60333	Hose Assembly	1
24	49312	Hose Assembly	2
25	60227	Fitting, Straight, Lengthening	4
26	60226	Fitting, Straight, Lengthening	4
27	49313	Hose Assembly	4
28	49314	Hose Assembly	2
29	49315	Hose Assembly	2
30	60797	Sensor	4
31	60168	Fitting, Straight, Pressure Gauge	3
32	43078	Fitting, Tee	8
33	60380	Hose Assembly	2
34	43658	Fitting, Straight, Bulkhead	4
35	43077	Fitting, 90°	4

36	60377	Hose Assembly	1
37	49316	Hose Assembly	2
38	47896	Fitting, Customize	1
39	60386	Hose Assembly	1
40	49317	Hose Assembly	1
41	60086	Fitting, Straight	1
42	60376	Hose Assembly	1
43	49318	Hose Assembly	1
44	49319	Hose Assembly	1

THIS PAGE HAS BEEN INTENTIONALLY LEFT BLANK

Item	Part Number	Description	Qty.
1	46792	Fitting, Straight	22
2	47896	Fitting, Straight	4
3	60392	Hose Assembly	6
4	43077	Fitting, 90°	4
5	43078	Fitting, Tee	2
6	43658	Fitting, Straight, Bulkhead	4
7	49320	Hose Assembly	2
8	49321	Hose Assembly	1
9	60396	Hose Assembly	1
10	49322	Hose Assembly	1
11	60391	Hose Assembly	1
12	46841	Fitting, Straight	10
13	46870	Fitting, Straight	1
14	43206	Fitting, 90°	2
15	45529	Fitting, Straight	4
16	60329	Hose Assembly	1
17	60331	Hose Assembly	1
18	60330	Hose Assembly	1
19	60416	Fitting, Customize	4
20	49323	Hose Assembly	2
21	46337	Fitting, 45°	8
22	49324	Hose Assembly	2
23	49326	Hose Assembly	2
24	49327	Hose Assembly	2
25	60797	Pressure Sensor	1

Turntable Circuit Part 1

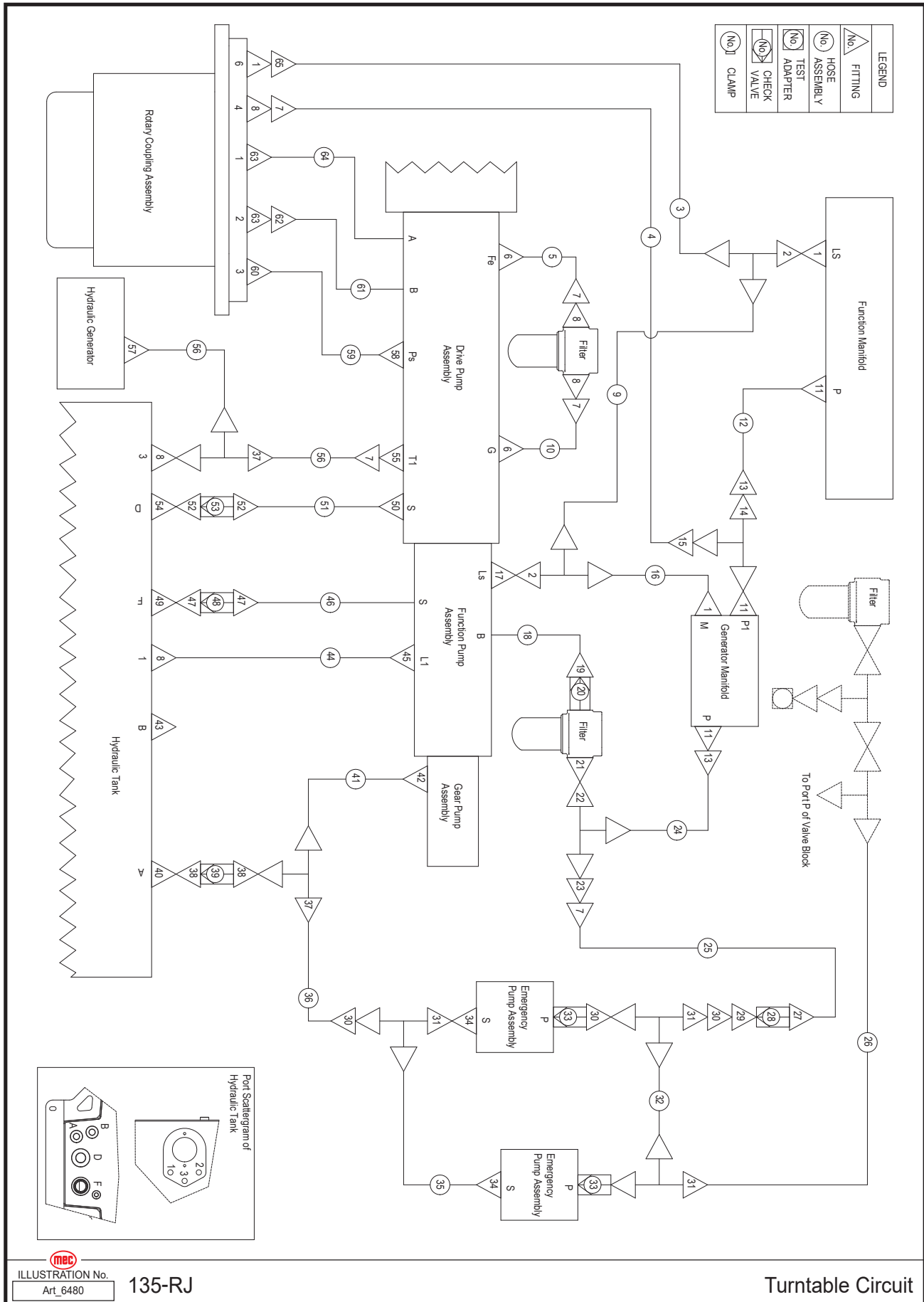

Item	Part Number	Description	Qty.
1	46792	Fitting, Straight	3
2	43078	Fitting, Tee	2
3	60342	Hose Assembly	1
4	60350	Hose Assembly	1
5	60345	Hose Assembly	1
6	43582	Fitting, Straight	2
7	43206	Fitting, 90°	5
8	45529	Fitting, Straight	5
9	60343	Hose Assembly	1
10	60346	Hose Assembly	1
11	60085	Fitting, Straight	3
12	49328	Hose Assembly	1
13	45587	Fitting, 90°	2
14	49329	Fitting, Straight	1
15	60222	Fitting, Straight, Red	1
16	49330	Hose Assembly	1
17	60086	Fitting, Straight	1
18	60336	Hose Assembly	1
--	60198	SAE Flange Fitting	1
--	60842	Spring Washer	4
--	60061	Screw SHCS M10-1.50 × 30 ZP	4
19	60087	Fitting, 90°	1
20	60790	Check Valve	1
21	60162	Fitting, Straight, Swivel	1
22	60165	Fitting, Tee, Red	1
23	60222	Fitting, Straight, Red	1
24	49328	Hose Assembly	1
25	60353	Hose Assembly	1
26	49331	Hose Assembly	1
27	45547	Fitting, Straight	1
28	48401	Check Valve	1
29	60146	Fitting, Straight, Swivel	1
30	43082	Fitting, 90°	3
31	43081	Fitting, Tee	3
32	60586	Tube, Steel	1
33	47759	Check Valve	2
34	60170	Fitting, Elbow	2
35	60587	Tube, Steel	1
36	60352	Hose Assembly	1
37	43117	Fitting, Tee	2
38	45537	Fitting, Straight	2
39	45539	Valve, Ball	1
40	45528	Fitting, Straight, Swivel	1
41	60344	Hose Assembly	1

42	48954	Fitting, Straight	1
43	47766	Plug	1
44	60347	Hose Assembly	1
45	43205	Fitting, Straight	1
46	60335	Hose Assembly	1
--	60178	SAE Flange Fitting	1
--	60843	Spring Washer	4
--	60174	Screw SHCS M12-1.75 × 35 ZP	4
47	45569	Fitting, Straight	2
48	45570	Valve, Ball	1
49	45568	Fitting, Straight, Swivel	1
50	43085	Fitting, Straight	1
51	60341	Hose Assembly	1
52	45573	Fitting, Straight	2
53	45574	Valve, Ball	1
54	45575	Fitting, Straight, Swivel	1
55	43080	Fitting, Straight	1
56	60397	Hose Assembly	2
57	45567	Fitting, Straight	1
58	60078	Fitting, Straight	1
59	60348	Hose Assembly	1
60	48399	Fitting, Straight	1
61	60338	Hose Assembly	1
--	48949	SAE Flange Fitting	1
--	60842	Spring Washer	4
--	60109	Screw SHCS M10-1.50 × 35 ZP	4
62	43459	Fitting, 90°	1
63	45563	Fitting, Straight	2
64	60337	Hose Assembly	1
65	43077	Fitting, 90°	1

THIS PAGE HAS BEEN INTENTIONALLY LEFT BLANK

Item	Part Number	Description	Qty.
1	45547	Fitting, Straight	2
2	43082	Fitting, 90°	2
3	60324	Hose Assembly	1
4	60531	Hose Assembly	1
5	48954	Fitting, Straight	1
6	45529	Fitting, Straight	3
7	48272	Hose Assembly	1
8	60071	Fitting, Straight	2
9	43119	Plug	2
10	45583	Fitting, Straight	1
11	45609	Fitting, Tee	2
12	60177	Fitting, Straight	1
13	43085	Fitting, Straight	1
14	60369	Hose Assembly	1
15	60146	Fitting, Straight, Swivel	1
16	45593	Fitting, Straight	2
17	43081	Fitting, Tee	2
18	60169	Fitting, Straight, Pressure Gauge	1
19	60797	Sensor	1
20	43657	Fitting, Straight, Bulkhead	3
21	60356	Hose Assembly	1
22	49332	Hose Assembly	1
23	49333	Hose Assembly	1
24	49334	Hose Assembly	1
25	60366	Hose Assembly	1
26	43680	Fitting, Straight, Bulkhead	3
27	49335	Hose Assembly	1
28	49336	Hose Assembly	1
29	49337	Hose Assembly	1
30	43083	Fitting, Straight	1
31	45563	Fitting, Straight	1
32	45613	Fitting, Straight	1
33	49338	Hose Assembly	1
34	49339	Hose Assembly	1
35	48388	Fitting, Straight	1
36	48972	Fitting, Straight	1
37	49340	Hose Assembly	1
38	60355	Hose Assembly	1
39	60083	Fitting, Straight	1
40	46792	Fitting, Straight	1
41	43077	Fitting, 90°	1
42	60323	Hose Assembly	1
43	60349	Hose Assembly	1
44	43117	Fitting, Tee	1

45	60167	Fitting, Straight, Red	1
46	60221	Fitting, Straight	2
47	60357	Hose Assembly	1
48	60163	Fitting, Straight	1
49	60463	Tube, Steel	1
50	45525	Fitting, Straight	1

THIS PAGE HAS BEEN INTENTIONALLY LEFT BLANK

Telescopic Boom Circuit

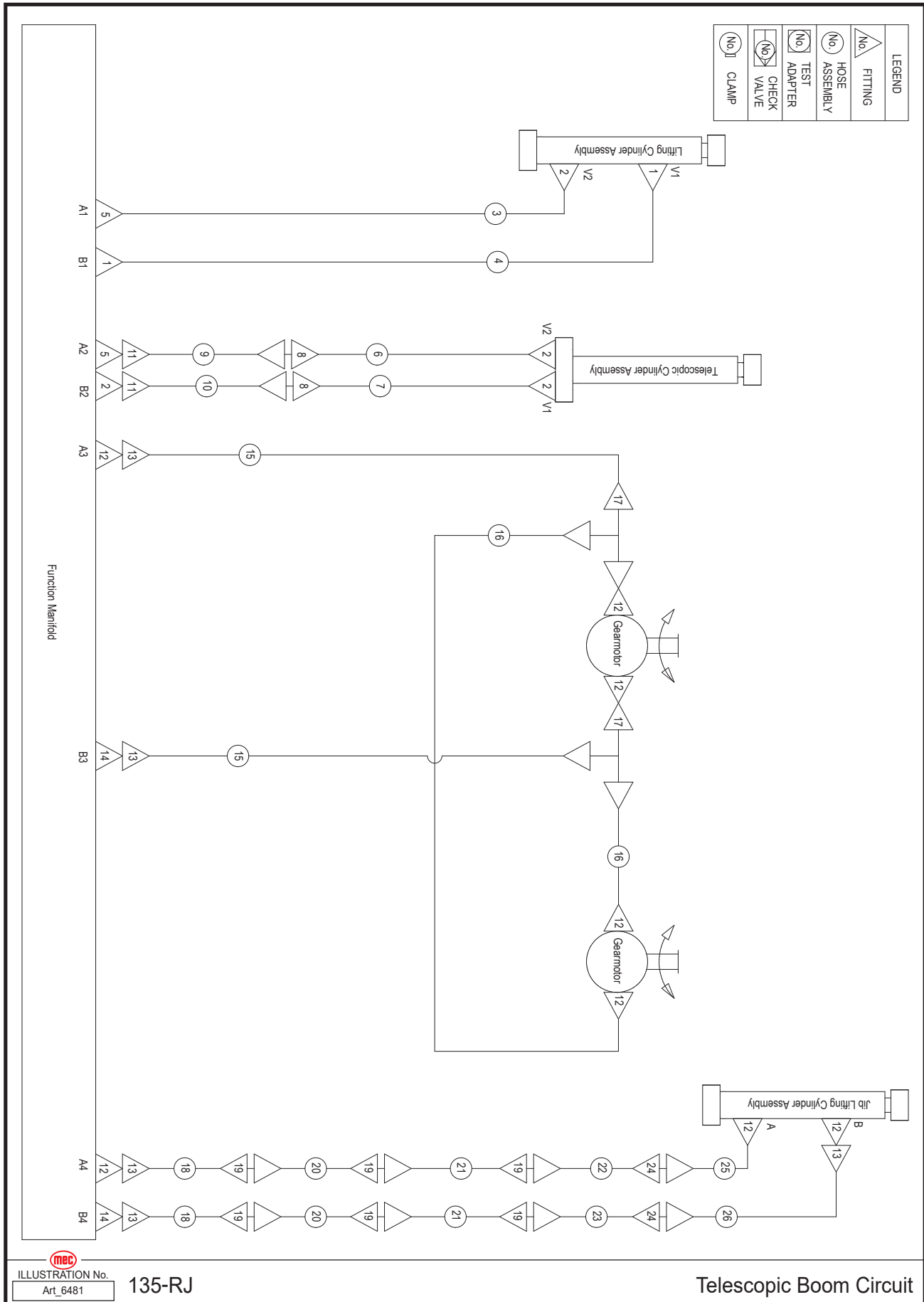

Item	Part Number	Description	Qty.
1	60084	Fitting, Straight	2
2	45563	Fitting, Straight	4
3	60339	Hose Assembly	1
4	60340	Hose Assembly	1
5	60223	Fitting, Straight	2
6	60588	Tube, Steel	1
7	60589	Tube, Steel	1
8	60164	Fitting, Straight	2
9	60358	Hose Assembly	1
10	60359	Hose Assembly	1
11	43459	Fitting, 90°	2
12	45547	Fitting, Straight	8
13	43082	Fitting, 90°	5
14	60416	Fitting, Customize	2
15	60354	Hose Assembly	2
16	60325	Hose Assembly	2
17	43081	Fitting, Tee	2
18	60398	Hose Assembly	2
19	43680	Fitting, Straight, Bulkhead	6
20	49335	Hose Assembly	2
21	49341	Hose Assembly	2
22	49342	Tube, Steel	1
23	49343	Tube, Steel	1
24	60155	Fitting, Straight	2
25	49344	Hose Assembly	1
26	60155	Hose Assembly	1

Jib Circuit

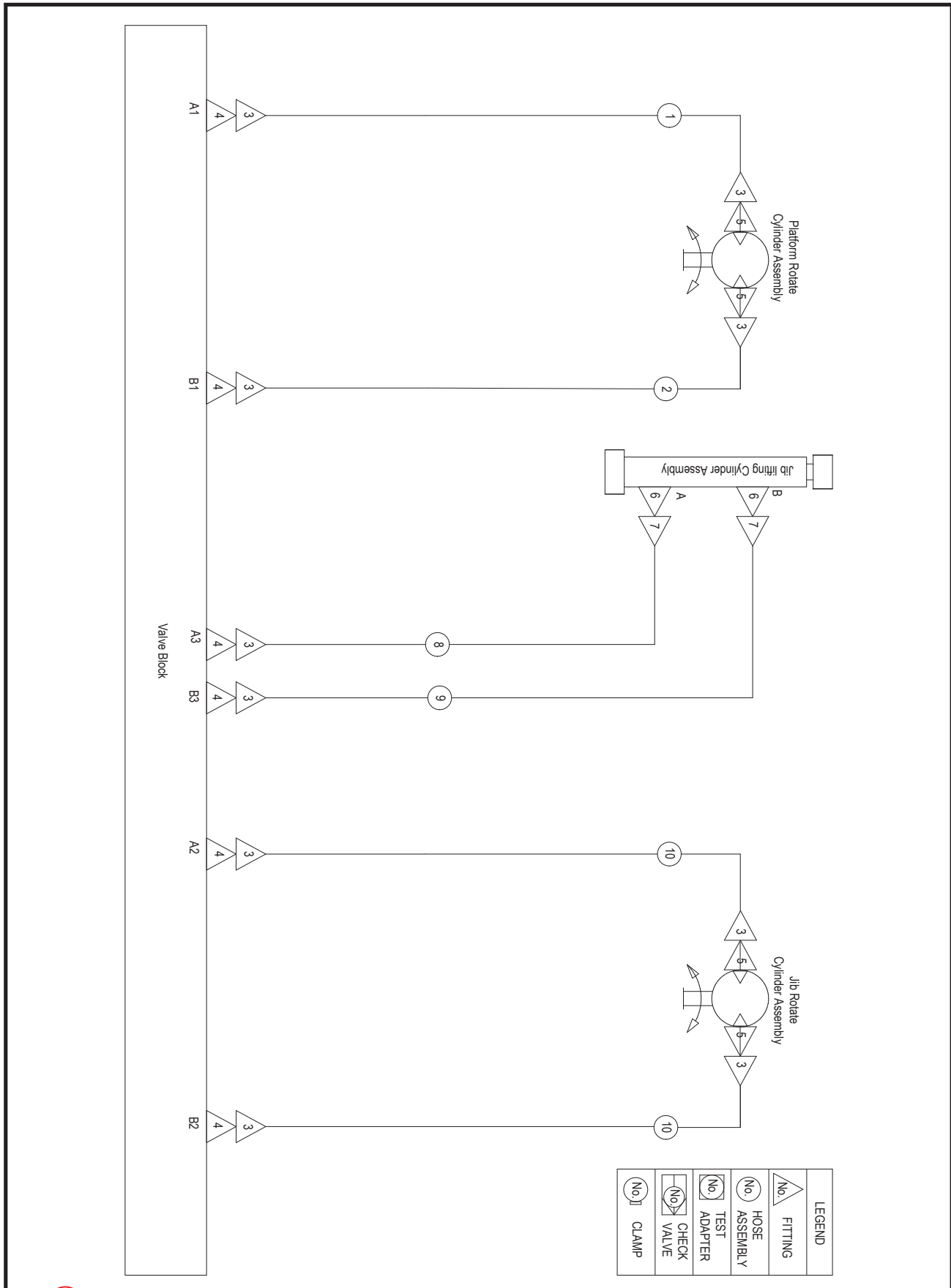

LEGEND	
(No.)	FITTING
(No.)	HOSE
(No.)	ASSEMBLY
(No.)	TEST ADAPTER
(No.)	CHECK VALVE
(No.)	CLAMP

ILLUSTRATION No. Art_6482

135-RJ

Jib Circuit

Item	Part Number	Description	Qty.
1	49345	Hose Assembly	1
2	49346	Hose Assembly	1
3	43077	Fitting, 90°	10
4	43076	Fitting, Straight	6
5	60086	Fitting, Straight	4
6	60416	Customized Fitting	2
7	48913	Fitting, Straight	2
8	49347	Hose Assembly	1
9	49348	Hose Assembly	1
10	49349	Hose Assembly	2

Electrical Harness Part 1

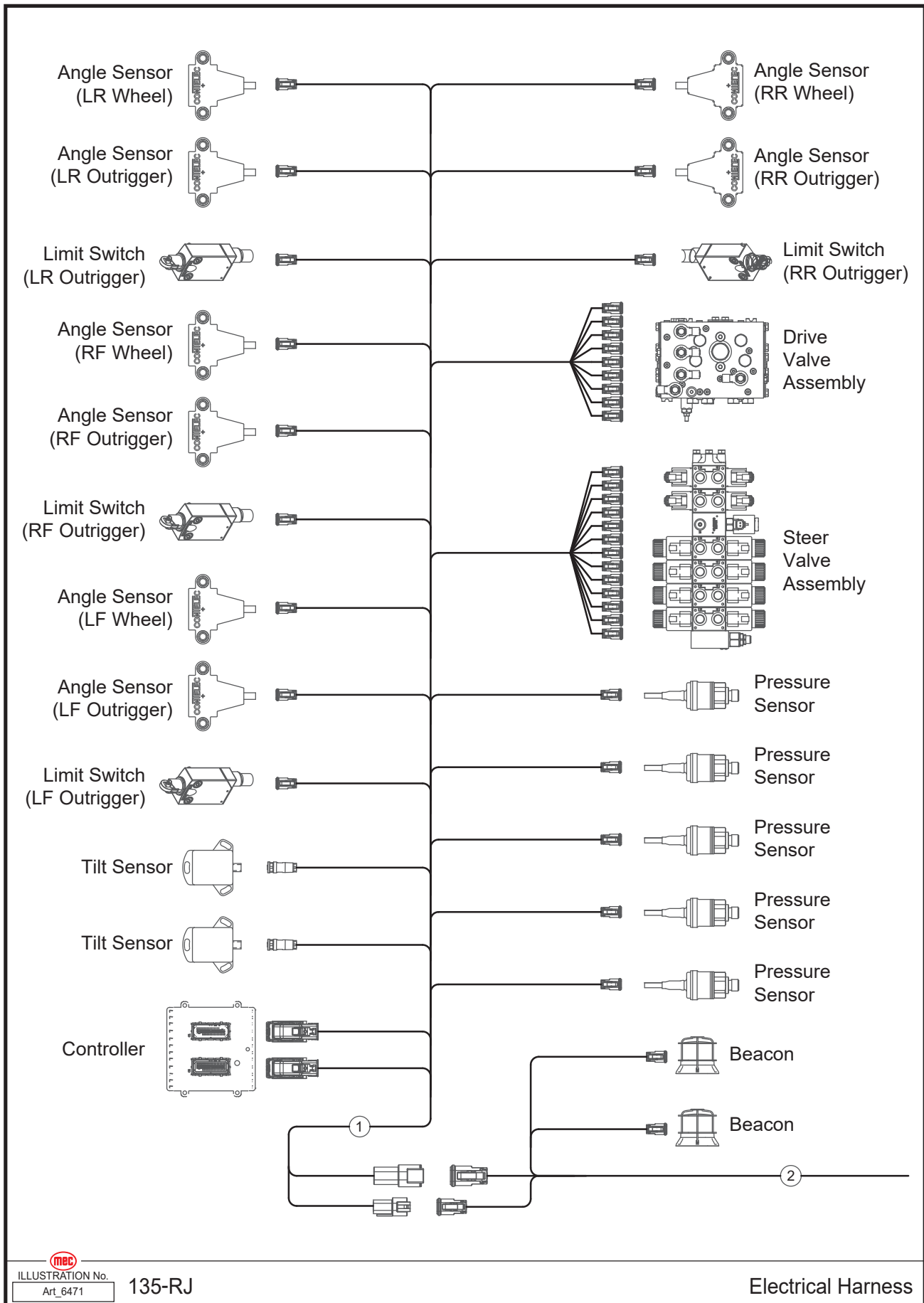

ILLUSTRATION No. 135-RJ
Art_6471

Electrical Harness

Item	Part Number	Description	Qty.
1	60202	Chassis Harness	1
2	60203	Turntable Harness	1

Electrical Harness Part 2

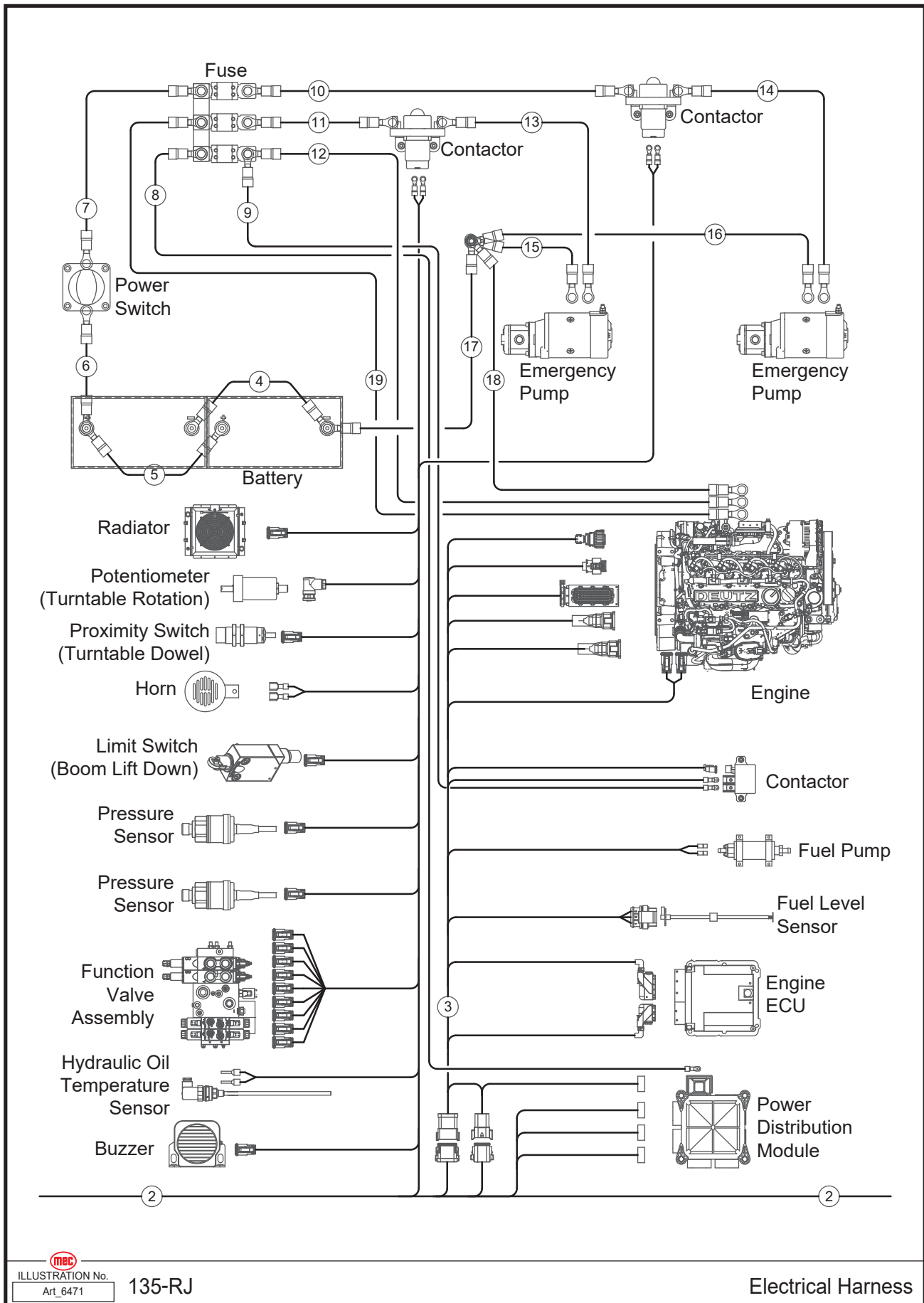
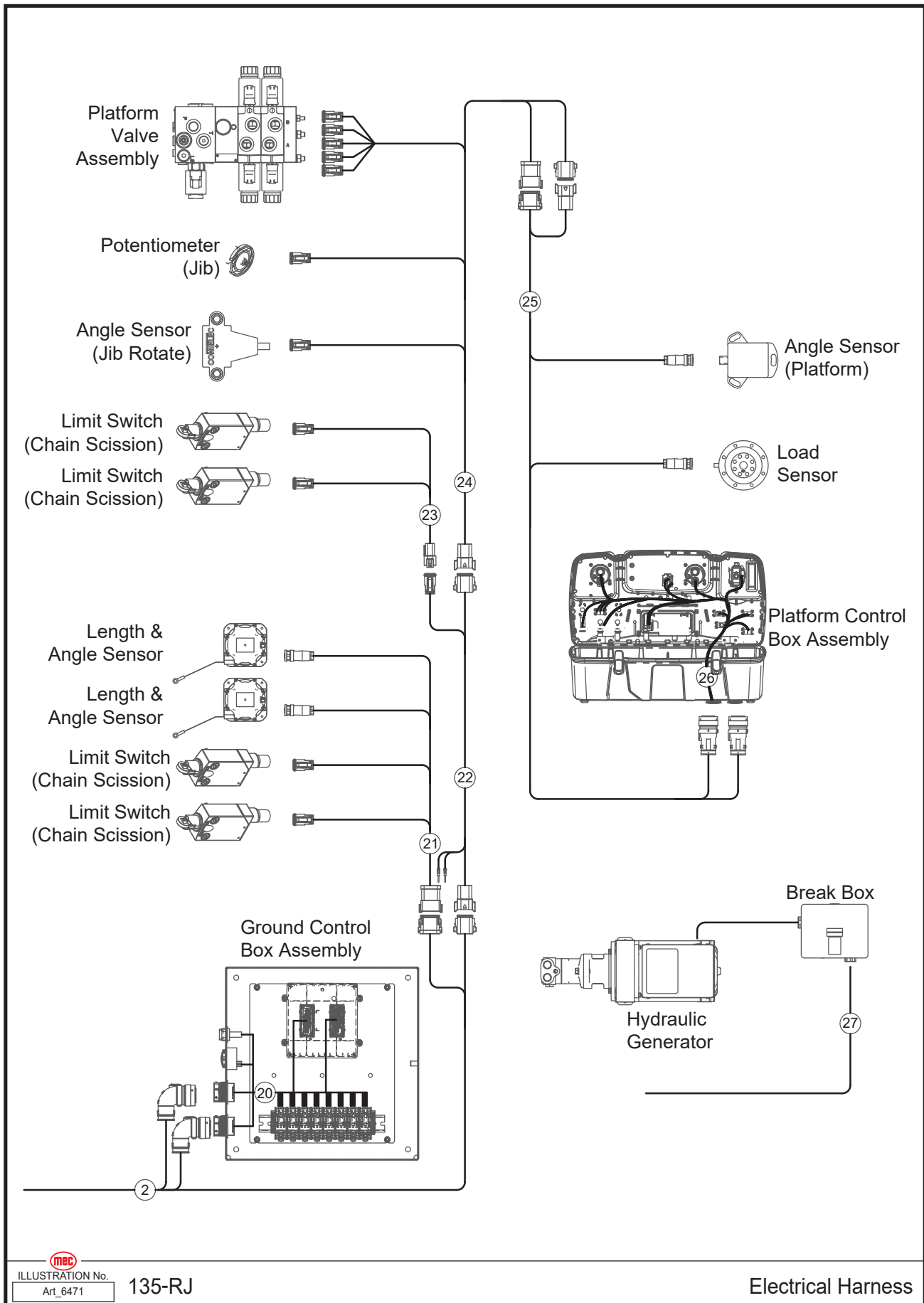



ILLUSTRATION No. **135-RJ**
 Art_6471

Electrical Harness

Item	Part Number	Description	Qty.
2	60203	Turntable Harness	1
3	49350	Engine Harness	1
4	60230	12V Battery Negative Shunt Harness	1
5	60229	12V Battery Positive Shunt Harness	1
6	60231	Power Switch Harness	1
7	60232	Fuse Harness	1
8	60233	Fuse Box Power Harness	1
9	60241	Preheat Contactor Harness	1
10	60234	Emergency Pump Contactor Harness 1	1
11	60235	Emergency Pump Contactor Harness 2	1
12	60244	Alternator Harness	1
13	60237	Emergency Pump Positive Harness 2	1
14	60236	Emergency Pump Positive Harness 1	1
15	60239	Emergency Pump Negative Harness 2	1
16	60238	Emergency Pump Negative Harness 1	1
17	60240	12V Battery Negative Harness	1
18	60243	Engine Negative Harness	1
19	60242	Start Motor Harness	1

Electrical Harness Part 3

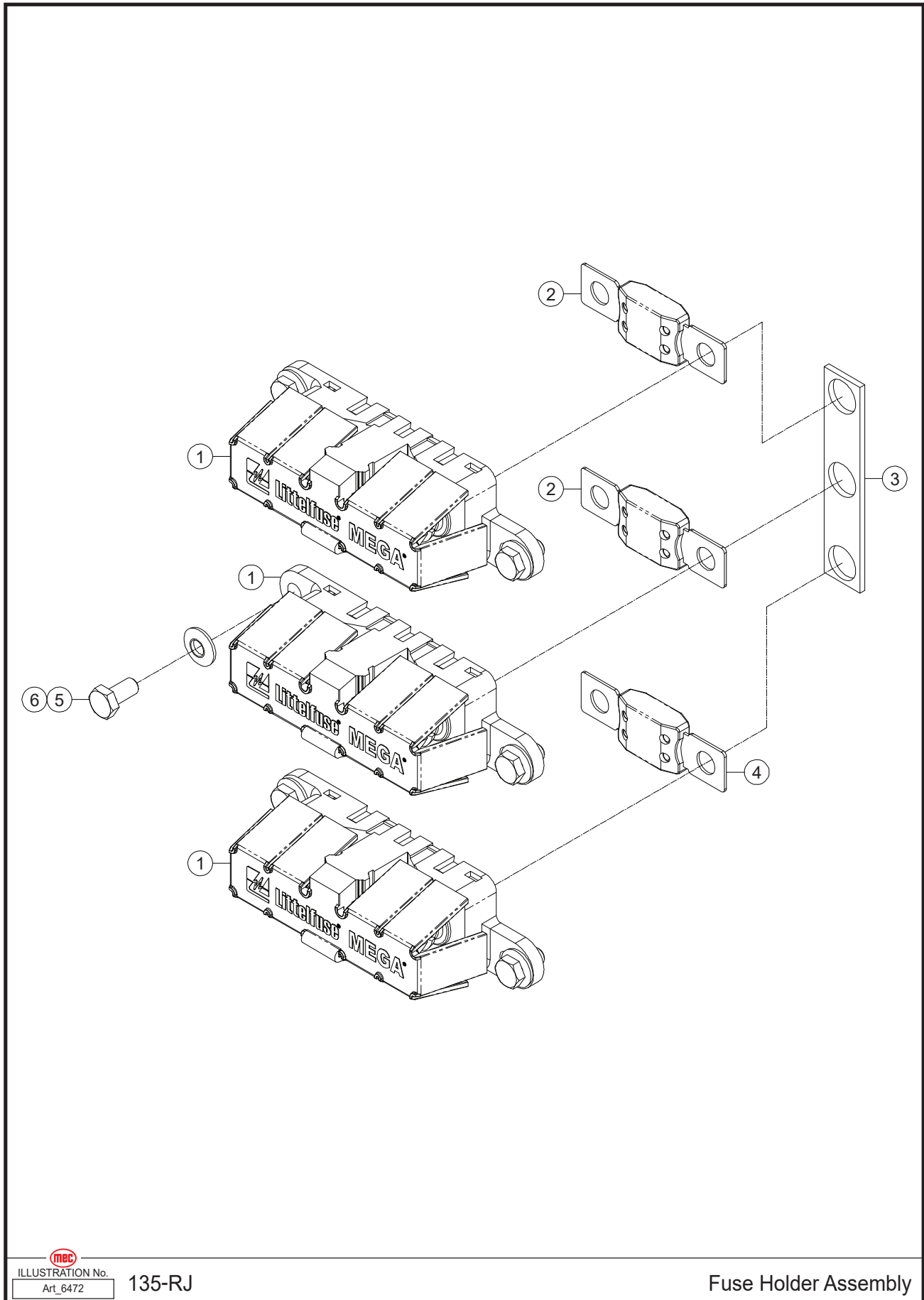



ILLUSTRATION No. 135-RJ
Art_6471

Electrical Harness

Item	Part Number	Description	Qty.
2	60203	Turntable Harness	1
20	49351	Ground Control Box Harness	1
21	60205	Sensor and Chain Scission Limit Switch Harness	1
22	60247	Main Boom Harness	1
23	60206	Chain Scission Limit Switch Harness 2	1
24	60318	Jib Harness	1
25	60317	Platform Harness	1
26	60316	Platform Control Box Harness	1
27	49352	Welding Harness	1

Fuse Holder Assembly

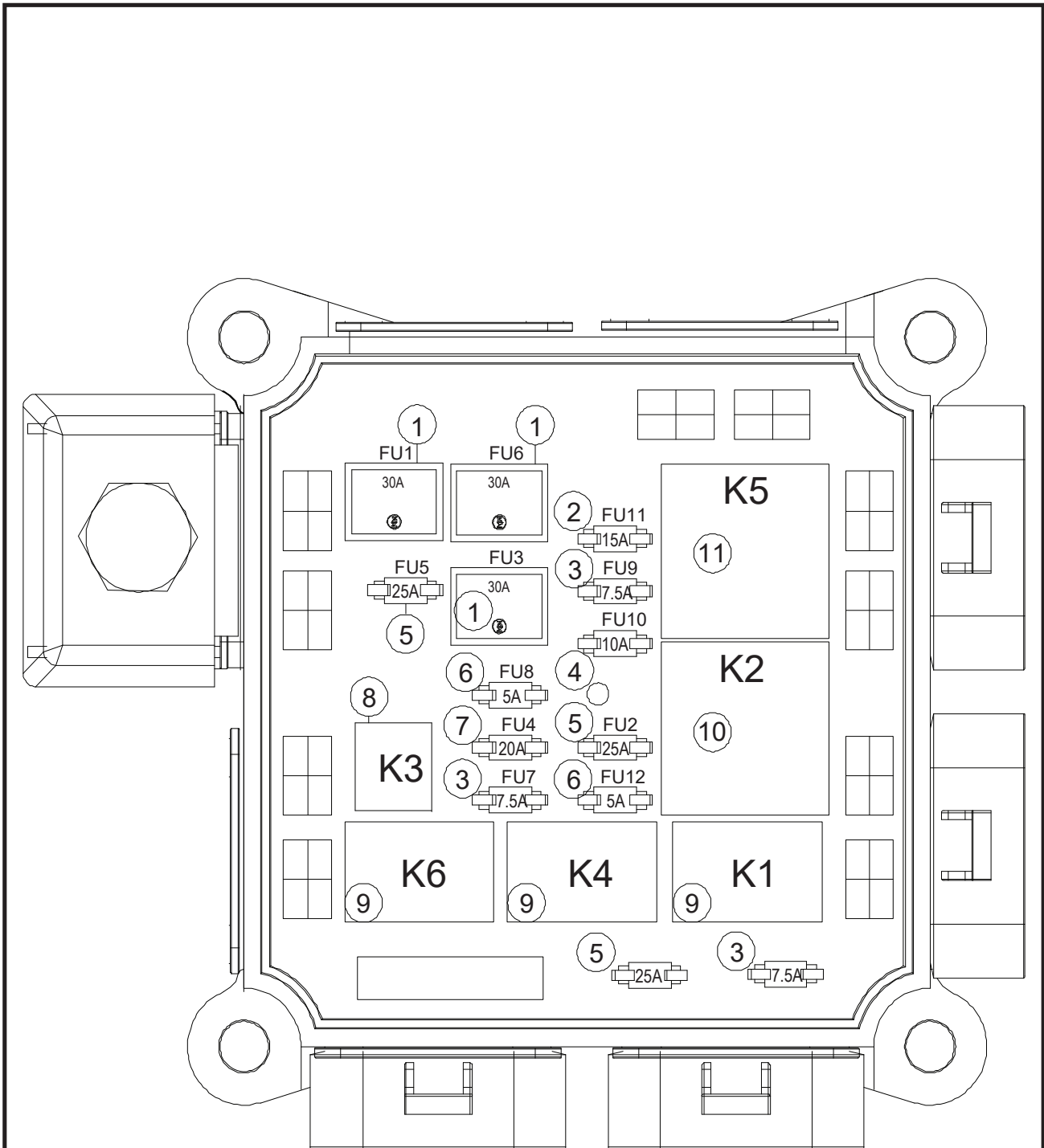

 ILLUSTRATION No. 135-RJ
Art_6472

Fuse Holder Assembly

Item	Part Number	Description	Qty.
1	60728	Fuse Holder	3
2	60245	Fuse 175A	2
3	60729	Bus Bar	1
4	60246	Fuse 225A	1
5	60026	Screw HHCS M06-1.00 × 12 ZP	6
6	48186	Spring Washer	6

Power Distribution Module



Item	Part Number	Description	Qty.
1	48137	Fuse 30A	3
2	48138	Fuse 15A	1
3	48139	Fuse 7.5A	3
4	48140	Fuse 10A	1
5	48141	Fuse 25A	2
6	48142	Fuse 5A	2
7	48143	Fuse 20A	1
8	48144	Relay	1
9	48145	Relay	3
10	48146	Relay	1
11	48147	Relay	1

Lower Control Box Assembly

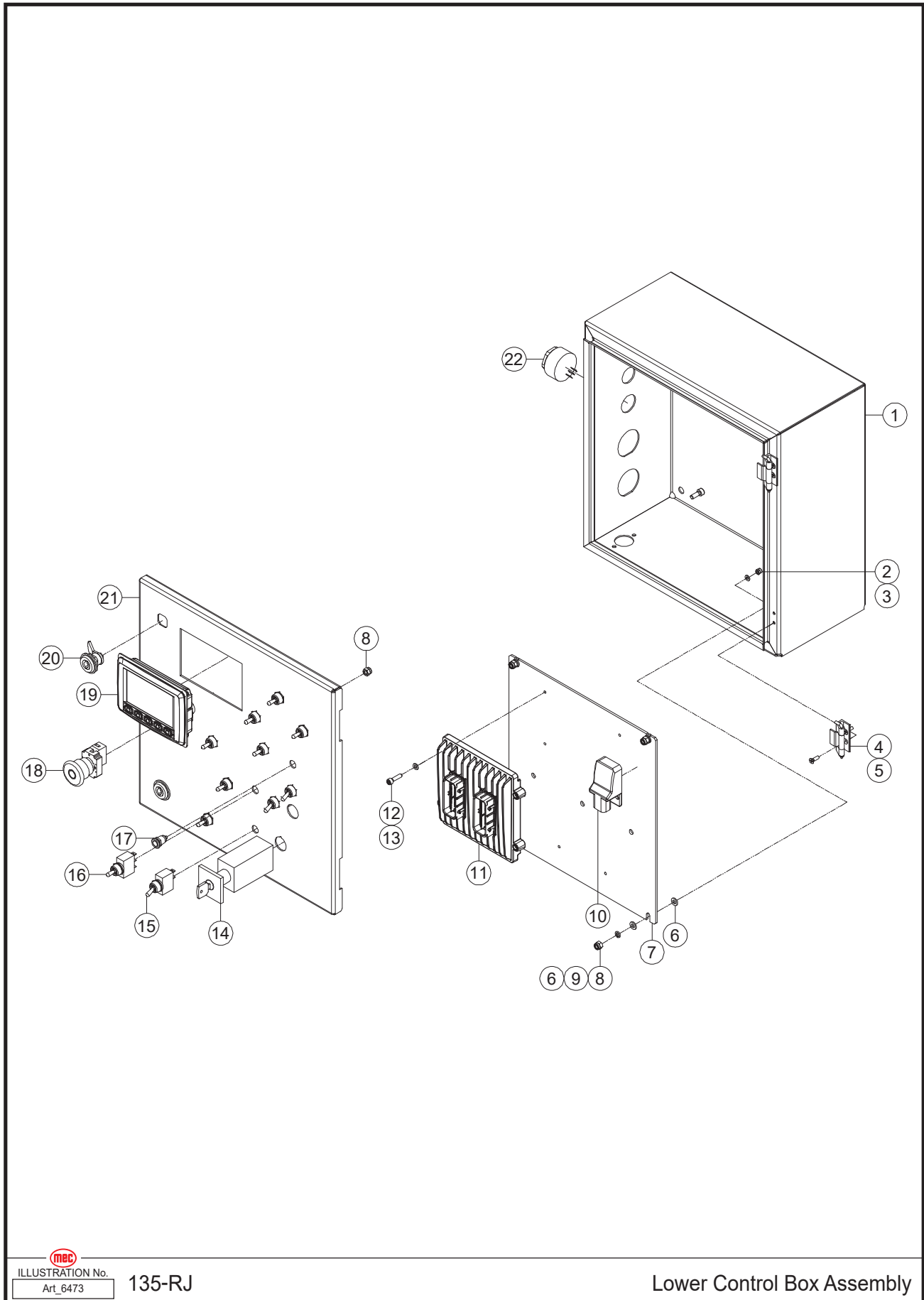

 ILLUSTRATION No. 135-RJ
Art_6473

Lower Control Box Assembly

Item	Part Number	Description	Qty.
1	60485	Control Box	1
2	60072	Nut NNYL M04-0.70 ZP	4
3	60029	WSHR M04 Standard Flat Washer ZP	4
4	46916	Rack, Gemel	2
5	53575	Screw CSCS M04-0.70 × 14 ZP	4
6	60015	WSHR M06 Standard Flat Washer ZP	8
7	60486	Plate, Bracket	1
8	60023	Nut NNYL M06-1.00 ZP	6
9	53046	WSHR M06 Spring Washer ZP	4
10	49353	Bluetooth Adapter	1
11	48150	Controller	1
12	60033	Screw SHCS M05-0.80 × 20 ZP	4
13	60006	WSHR M05 Standard Flat Washer ZP	4
14	48155	Key Switch	1
15	48163	Switch, Toggle	3
16	48151	Switch, Toggle	8
17	48152	Indicator	1
18	41422	Emergency Stop Switch	1
--	43097	Base With 1 NC Contact	1
--	43098	Red Mushroom Head	1
19	48159	Display	1
20	42352	Lock, Column	2
21	49354	Electric Control Box Cover	1
22	48160	Alarm	1

Upper Control Box Assembly

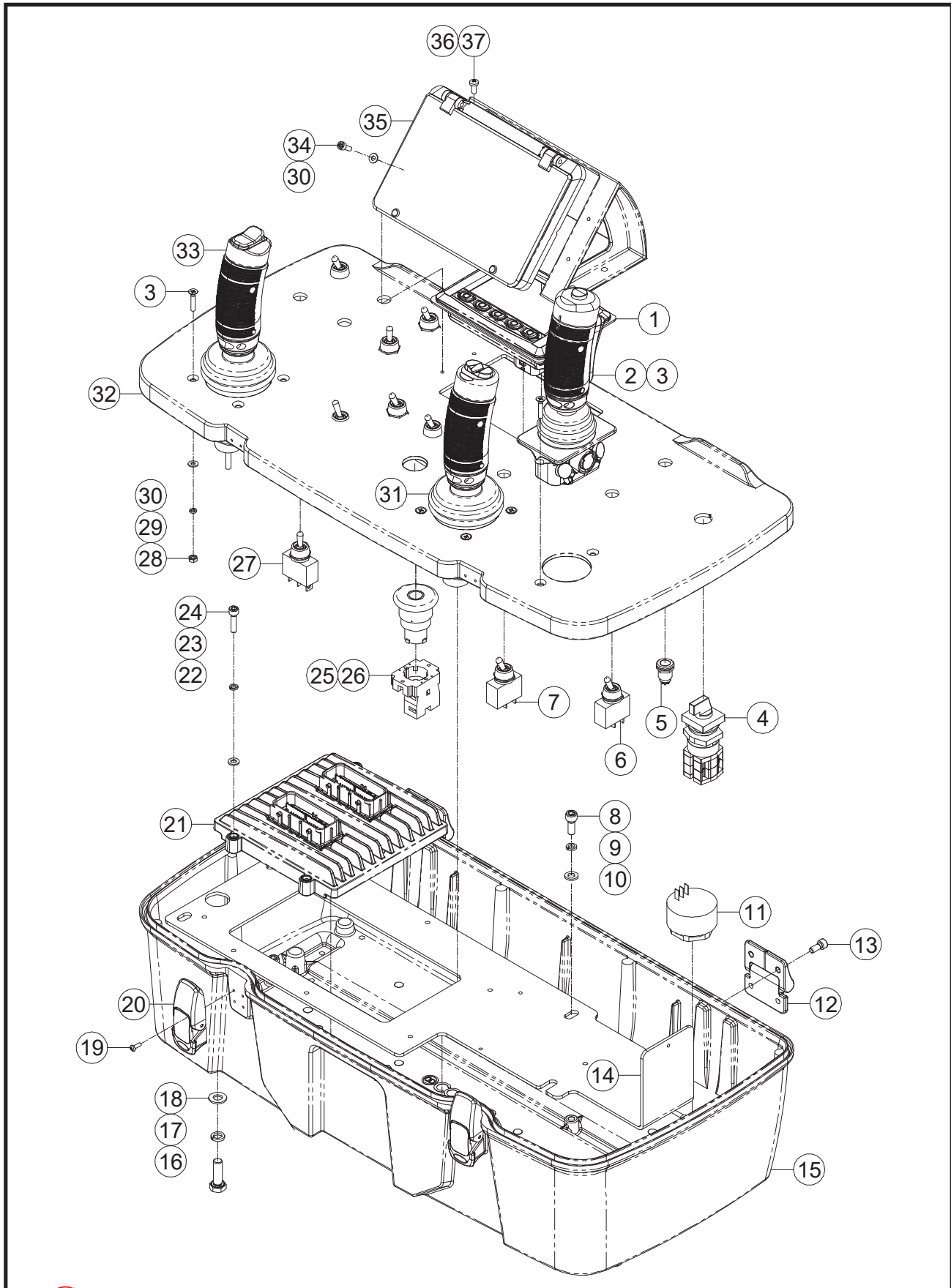
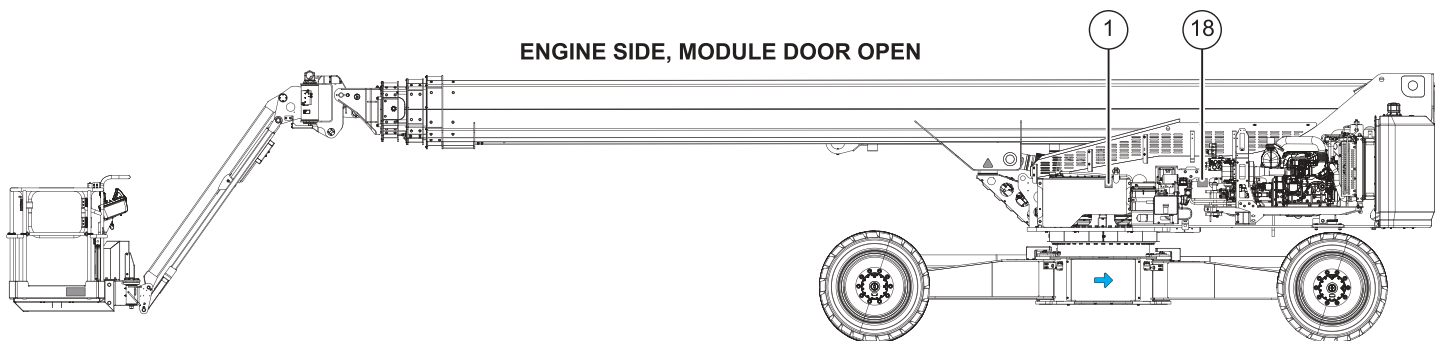
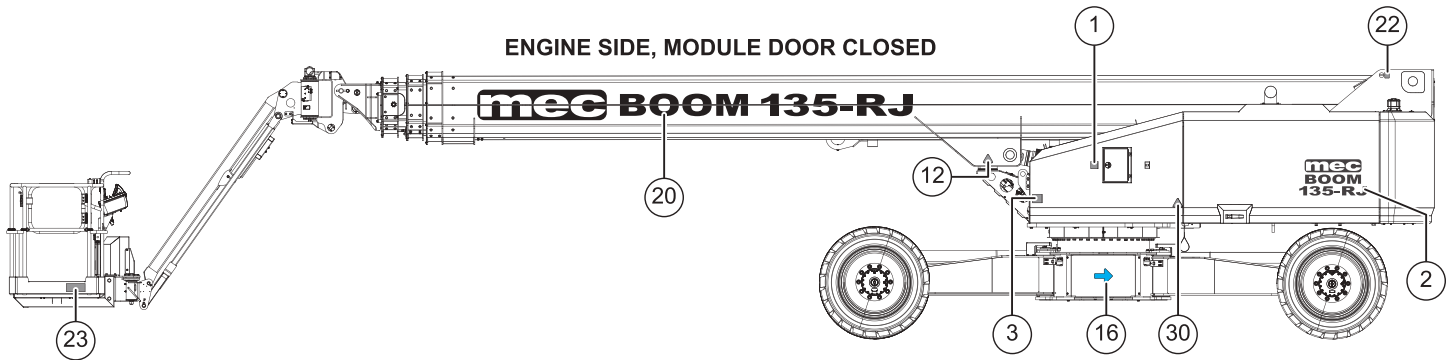
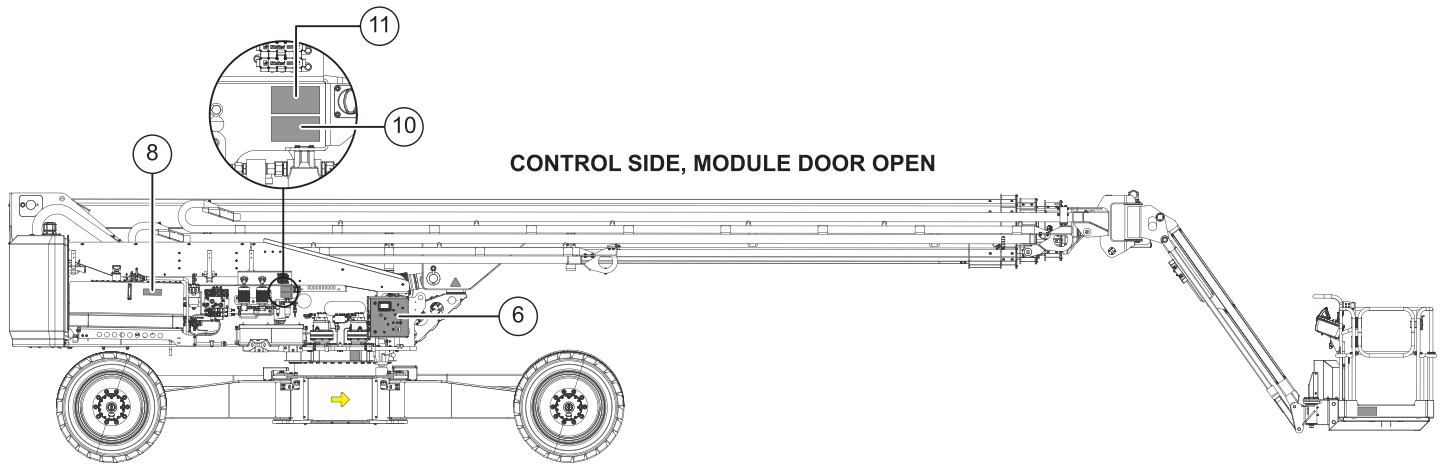
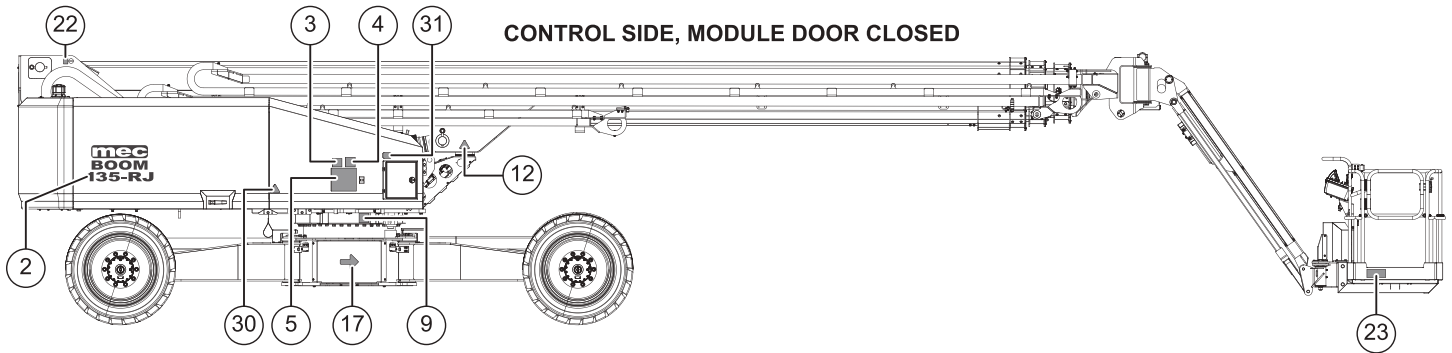

 ILLUSTRATION No. 135-RJ
Art_6474

Upper Control Box Assembly

Item	Part Number	Description	Qty.
1	60485	Box	1
2	60072	Nut NNYL M04-0.70 ZP	4
3	60029	WSHR M04 Standard Flat Washer ZP	4
4	46916	Rack, Gemel	2
5	53575	Screw CSCS M04-0.70 × 14 ZP	4
6	60015	WSHR M06 Standard Flat Washer ZP	8
7	60486	Plate, Bracket	1
8	60023	Nut NNYL M06-1.00 ZP	6
9	53046	WSHR M06 Spring Washer ZP	4
10	49353	Bluetooth Adapter	1
11	48150	Controller	1
12	60033	Screw SHCS M05-0.80 × 20 ZP	4
13	60006	WSHR M05 Standard Flat Washer ZP	4
14	48155	Key Switch	1
15	48163	Switch, Toggle	3
16	48151	Switch, Toggle	8
17	48152	Indicator	1
18	41422	Emergency Stop Switch	1
--	43097	Base With 1 NC Contact	1
--	43098	Red Mushroom Head	1
19	48159	Display	1
20	42352	Lock, Column	2
21	49354	Electric Control Box Cover	1
22	48160	Alarm	1

Decals





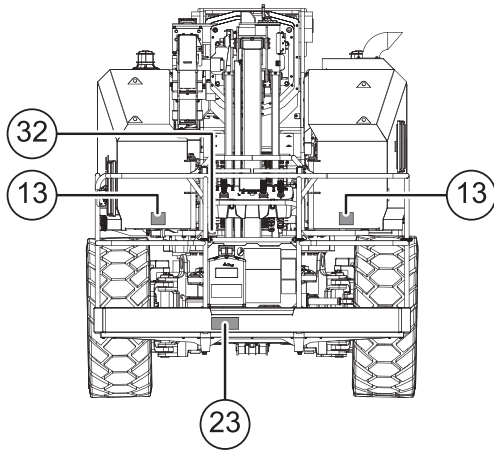



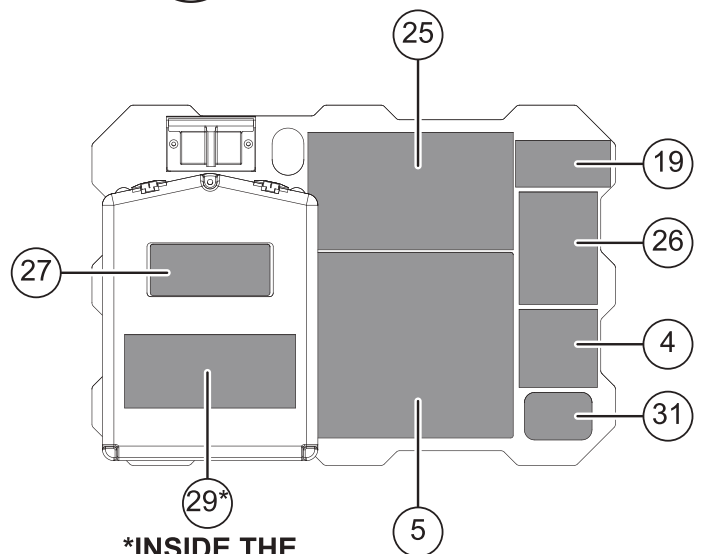
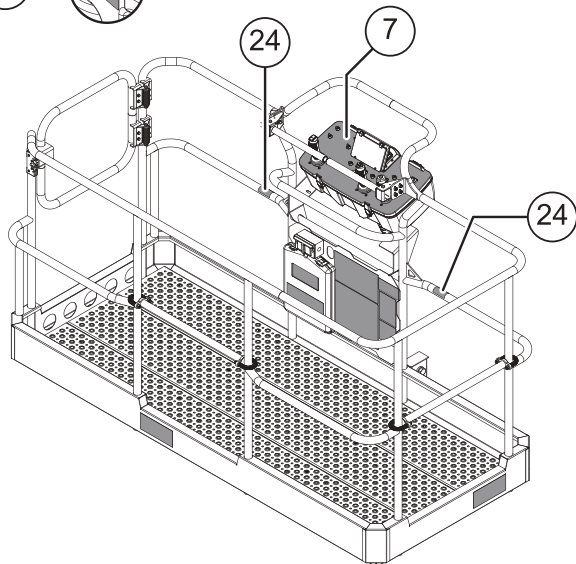
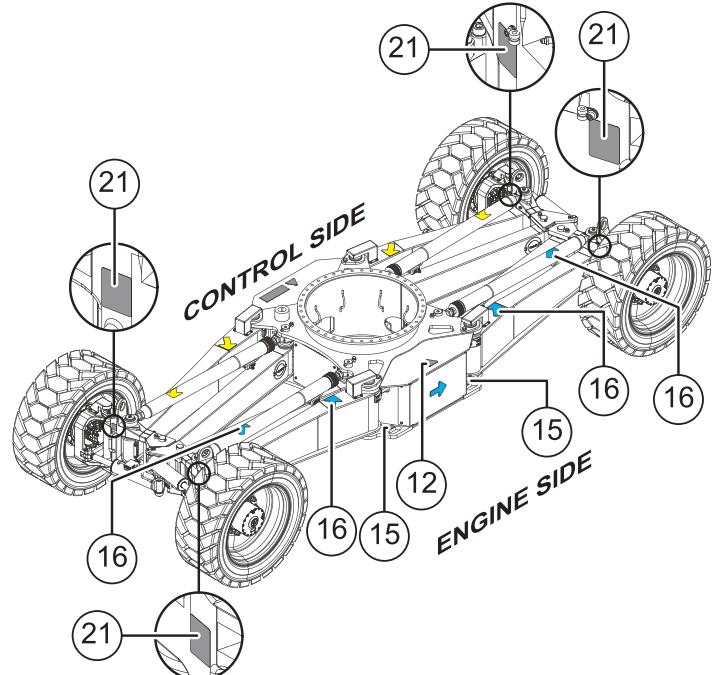
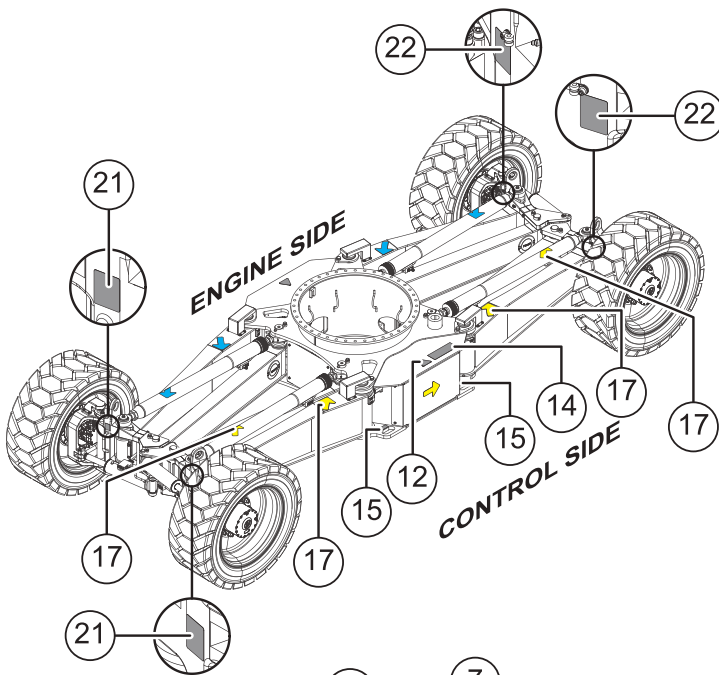
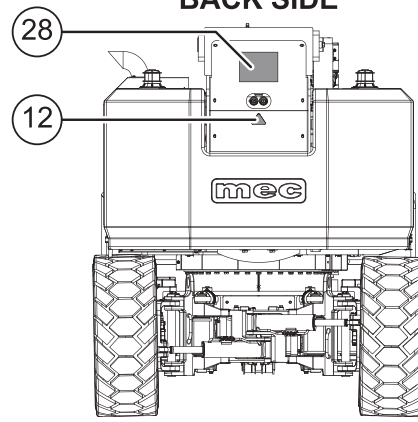



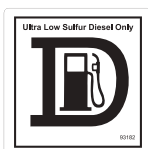



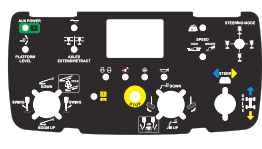
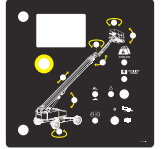
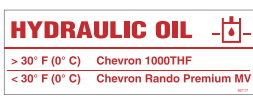
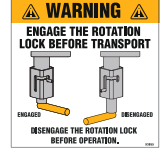
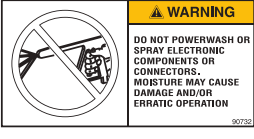



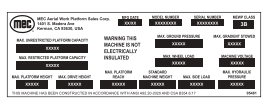

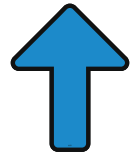

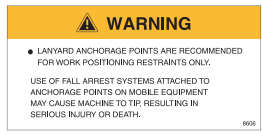
FRONT SIDE

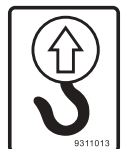
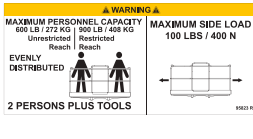

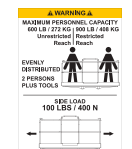
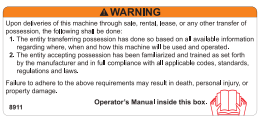
BACK SIDE



***INSIDE THE
MANUAL CASE**

<p>1</p>  <p>93182 Qty. - 2</p>	<p>2</p>  <p>96455 Qty. - 2</p>	<p>3</p>  <p>93801 Qty. - 2</p>	<p>4</p>  <p>93807 Qty. - 2</p>	<p>5</p>  <p>93755 Qty. - 2</p>
<p>6</p>  <p>49356 Qty. - 1</p>	<p>7</p>  <p>49355 Qty. - 1</p>	<p>8</p>  <p>92117 Qty. - 1</p>	<p>9</p>  <p>93855 Qty. - 1</p>	<p>10</p>  <p>90732 Qty. - 1</p>
<p>11</p>  <p>93805 Qty. - 1</p>	<p>12</p>  <p>91850 Qty. - 5</p>	<p>13</p>  <p>93804 Qty. - 2</p>	<p>14</p>  <p>95481 Qty. - 1</p>	<p>15</p>  <p>91973 Qty. - 4</p>
<p>16</p>  <p>96891 Qty. - 5</p>	<p>17</p>  <p>96892 Qty. - 5</p>	<p>18</p>  <p>93806 Qty. - 1</p>	<p>19</p>  <p>8606 Qty. - 1</p>	<p>20</p>  <p>96453 Qty. - 1</p>
<p>21</p>  <p>41635 Qty. - 6</p>	<p>22</p>  <p>41634 Qty. - 4</p>	<p>23</p>  <p>95823 Qty. - 3</p>	<p>24</p>  <p>91970 Qty. - 2</p>	<p>25</p>  <p>93754 Qty. - 1</p>
<p>26</p>  <p>95822 Qty. - 1</p>	<p>27</p>  <p>8911 Qty. - 1</p>	<p>28</p>  <p>90719 Qty. - 1</p>	<p>29</p>  <p>90718 Qty. - 1</p>	<p>30</p>  <p>9910 Qty. - 2</p>
<p>31</p>  <p>96932 Qty. - 2</p>	<p>32</p>  <p>90751 Qty. - 1</p>			

Notes

Notes

Notes



Limited Owner Warranty

MEC Aerial Platform Sales Corp. warrants its equipment to the original purchaser against defects in material and/or workmanship under normal use and service for one (1) year from date of registered sale or date the unit left the factory if not registered. MEC Aerial Platform Sales Corp. further warrants the structural weldments of the main frame and scissor arms to be free from defects in material or workmanship for five (5) years from date of registered sale or date unit left the factory if not registered. Excluded from such warranty is the battery(s) which carries a ninety (90) day warranty from described purchase date. Warranty claims within such warranty period shall be limited to repair or replacement, MEC Aerial Platform Sales Corp's option, of the defective part in question and labor to perform the necessary repair or replacement based on MEC Aerial Platform Sales Corp's then current flat rate, provided the defective part in question is shipped prepaid to MEC Aerial Platform Sales Corp. and is found upon inspection by MEC Aerial Platform Sales Corp. to be defective in material and/or workmanship. MEC Aerial Platform Sales Corp. shall not be liable for any consequential, incidental or contingent damages whatsoever. Use of other than factory authorized parts; misuse, improper maintenance, or modification of the equipment voids this warranty. The foregoing warranty is exclusive and in lieu of all other warranties, express or implied. All such other warranties, including implied warranties of merchantability and of fitness for a particular purpose, are hereby excluded. No Dealer, Sales Representative, or other person purporting to act on behalf of MEC Aerial Platform Sales Corp. is authorized to alter the terms of this warranty, or in any manner assume on behalf of MEC Aerial Platform Sales Corp. any liability or obligation which exceeds MEC Aerial Platform Sales Corp's obligations under this warranty.



MEC Aerial Work Platforms

1401 S. Madera Avenue, Kerman, CA 93630 USA

Toll Free: 1-877-632-5438

Phone: 1-559-842-1500

Fax: 1-559-842-1520

info@MECawp.com

www.MECawp.com